

Instructions – Parts List



CARBON STEEL

Dura-Flo™ 1100 Pumps

308357G

With Severe-Duty Rod and Cylinder

**Part No. 236932 Pump, Series A, 74:1 Ratio
with Premier™ Air Motor and 236478 Displacement Pump**

50.0 MPa, 500 bar (7252 psi) Maximum Fluid Working Pressure

0.67 MPa, 6.7 bar (97 psi) Maximum Air Input Pressure



Important Safety Instructions

Read all warnings and instructions in this manual.
Save these instructions.

See page 2 for **Table of Contents**.

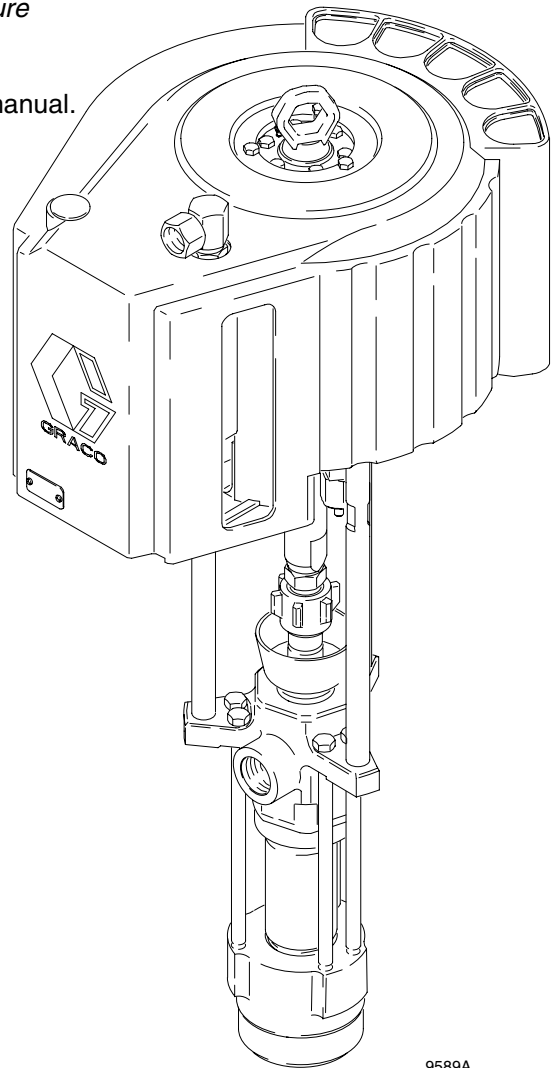

9589A

PROVEN QUALITY. LEADING TECHNOLOGY.



Table of Contents

Warnings	2	Parts Drawings and Parts Lists	18
Installation	6	Pump Assembly	18
Operation/Maintenance	8	Displacement Pump	19
Troubleshooting Chart	11	Repair Kits	20
Service	12	Technical Data	21
Required Tools	12	Dimensions	23
Disconnecting the Displacement Pump	12	Mounting Hole Layout	23
Reconnecting the Displacement Pump	12	Warranty	24
Displacement Pump Service	14	Graco Information	24

WARNING



INSTRUCTIONS

EQUIPMENT MISUSE HAZARD

Equipment misuse can cause the equipment to rupture or malfunction and result in serious injury.

- This equipment is for professional use only.
- Read all instruction manuals, tags, and labels before operating the equipment.
- Use the equipment only for its intended purpose. If you are uncertain about usage, call your Graco distributor.
- Do not alter or modify this equipment. Use only genuine Graco parts and accessories.
- Check equipment daily. Repair or replace worn or damaged parts immediately.
- Do not exceed the maximum working pressure of the lowest rated system component. Refer to the **Technical Data** on page 21 for the maximum working pressure of this equipment.
- Use fluids and solvents which are compatible with the equipment wetted parts. Refer to the **Technical Data** section of all equipment manuals. Read the fluid and solvent manufacturer's warnings.
- Do not exceed the maximum working pressure of the lowest rated system component. This equipment has a **50.0 MPa, 500 bar (7252 psi) maximum working pressure**.
- Do not kink or overbend hoses or use hoses to pull equipment.
- Route hoses away from traffic areas, sharp edges, moving parts, and hot surfaces. Do not expose Graco hoses to temperatures above 82°C (180°F) or below -40°C (-40°F).
- Wear hearing protection when operating this equipment.
- Do not lift pressurized equipment.
- Comply with all applicable local, state, and national fire, electrical, and safety regulations.
- Do not lift the sprayer by the lift ring when the total weight exceeds 550 lb (250 kg).

WARNING



SKIN INJECTION HAZARD

Spray from the gun, hose leaks, or ruptured components can inject fluid into your body and cause extremely serious injury, including the need for amputation. Fluid splashed in the eyes or on the skin can also cause serious injury.

- Fluid injected into the skin might look like just a cut, but it is a serious injury. **Get immediate surgical treatment.**
- Do not point the gun/valve at anyone or at any part of the body.
- Do not put your hand or fingers over the spray tip/nozzle.
- Do not stop or deflect leaks with your hand, body, glove or rag.
- Do not “blow back” fluid; this is not an air spray system.
- Always have the tip guard and the trigger guard on the gun when spraying.
- Be sure the gun/valve trigger safety operates before spraying.
- Lock the gun/valve trigger safety when you stop spraying.
- Follow the **Pressure Relief Procedure** on page 8 whenever you: are instructed to relieve pressure; stop spraying; clean, check, or service the equipment; and install or clean the spray tip.
- Tighten all fluid connections before operating the equipment.
- Check the hoses, tubes, and couplings daily. Replace worn, damaged, or loose parts immediately. Permanently coupled hoses cannot be repaired; replace the entire hose.
- Use only Graco approved hoses. Do not remove any spring guard that is used to help protect the hose from rupture caused by kinks or bends near the couplings.



MOVING PARTS HAZARD

Moving parts, such as the air motor piston, can pinch or amputate your fingers.

- Keep clear of all moving parts when starting or operating the pump.
- Before servicing the equipment, follow the **Pressure Relief Procedure** on page 8 to prevent the equipment from starting unexpectedly.

WARNING



FIRE AND EXPLOSION HAZARD

Improper grounding, poor ventilation, open flames or sparks can cause a hazardous condition and result in a fire or explosion and serious injury.

- Ground the equipment and the object being sprayed/dispensed. Refer to **Grounding** on page 5.
- If there is any static sparking or you feel an electric shock while using this equipment, **stop spraying immediately**. Do not use the equipment until you identify and correct the problem.
- Provide fresh air ventilation to avoid the buildup of flammable fumes from solvents or the fluid being sprayed/dispensed.
- Keep the spray/dispense area free of debris, including solvent, rags, and gasoline.
- Electrically disconnect all equipment in the spray/dispense area.
- Extinguish all open flames or pilot lights in the spray/dispense area.
- Do not smoke in the spray/dispense area.
- Do not turn on or off any light switch in the spray/dispense area while operating or if fumes are present.
- Do not operate a gasoline engine in the spray/dispense area.
- Keep a fire extinguisher in the work area.



TOXIC FLUID HAZARD

Hazardous fluid or toxic fumes can cause serious injury or death if splashed in the eyes or on the skin, inhaled, or swallowed.

- Know the specific hazards of the fluid you are using.
- Store hazardous fluid in an approved container. Dispose of hazardous fluid according to all local, state and national guidelines.
- Always wear protective eyewear, gloves, clothing and respirator as recommended by the fluid and solvent manufacturer.

Installation

Grounding

To reduce the risk of static sparking, ground the pump, object being sprayed, and all spray/dispensing equipment used or located in the spray/dispensing area. Check your local electrical code for detailed grounding instructions for your area and type of equipment. Be sure to ground all of this spray/dispensing equipment.

1. *Pump*: loosen the grounding lug locknut (W) and washer (X). Insert one end of a 1.5 mm² (12 ga) minimum ground wire (Y) into the slot in lug (Z) and tighten the locknut securely. See Fig. 1. Connect the other end of the wire to a true earth ground. Order Part No. 237569 Ground Wire and Clamp.
2. Air hoses: use only electrically conductive hoses.
3. Fluid hoses: use only electrically conductive fluid hoses.
4. Air compressor: follow manufacturer's recommendations.
5. Spray gun/dispensing valve: grounding is obtained through connection to a properly grounded fluid hose and pump.

6. Fluid supply container: according to your local code.
7. Object being sprayed: according to your local code.
8. All solvent pails used when flushing, according to your local code. Use only metal pails, which are conductive, placed on a grounded surface. Do not place the pail on a nonconductive surface, such as paper or cardboard, which interrupts the grounding continuity.
9. To maintain grounding continuity when flushing or relieving pressure, always hold a metal part of the spray gun/dispensing valve firmly to the side of a grounded metal pail, then trigger the gun/valve.

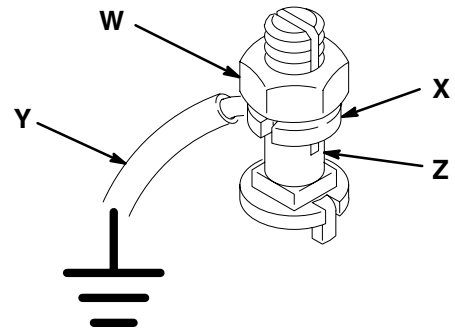

Fig. 1

0864

Installation

NOTE: Reference numbers and letters in parentheses in the text refer to the callouts in the figures and the parts drawing.

NOTE: Accessories are available from your Graco representative. If you supply your own accessories, be sure they are adequately sized and pressure-rated to meet the system's requirements.

Fig. 2 is only a guide for selecting and installing system components and accessories. Contact your Graco distributor for assistance in designing a system to suit your particular needs.

TYPICAL INSTALLATION

KEY

- | | | |
|---|--|---|
| A Pump | G Air Manifold | N Grounded Fluid Supply Hose |
| B Cart | H Electrically Conductive Air Supply Hose | P Fluid Whip Hose |
| C Pump Runaway Valve (location) | J Air Line Filter | R Gun Swivel |
| D Air Line Lubricator (location) | K Bleed-Type Master Air Valve (for accessories) | S Airless Spray Gun |
| E Bleed-Type Master Air Valve (required, for pump) | L Fluid Filter (includes drain valve) | T Suction Kit |
| F Pump Air Regulator | M Fluid Drain Valve (required) | Y Ground Wire (required; see page 5 for installation instructions) |

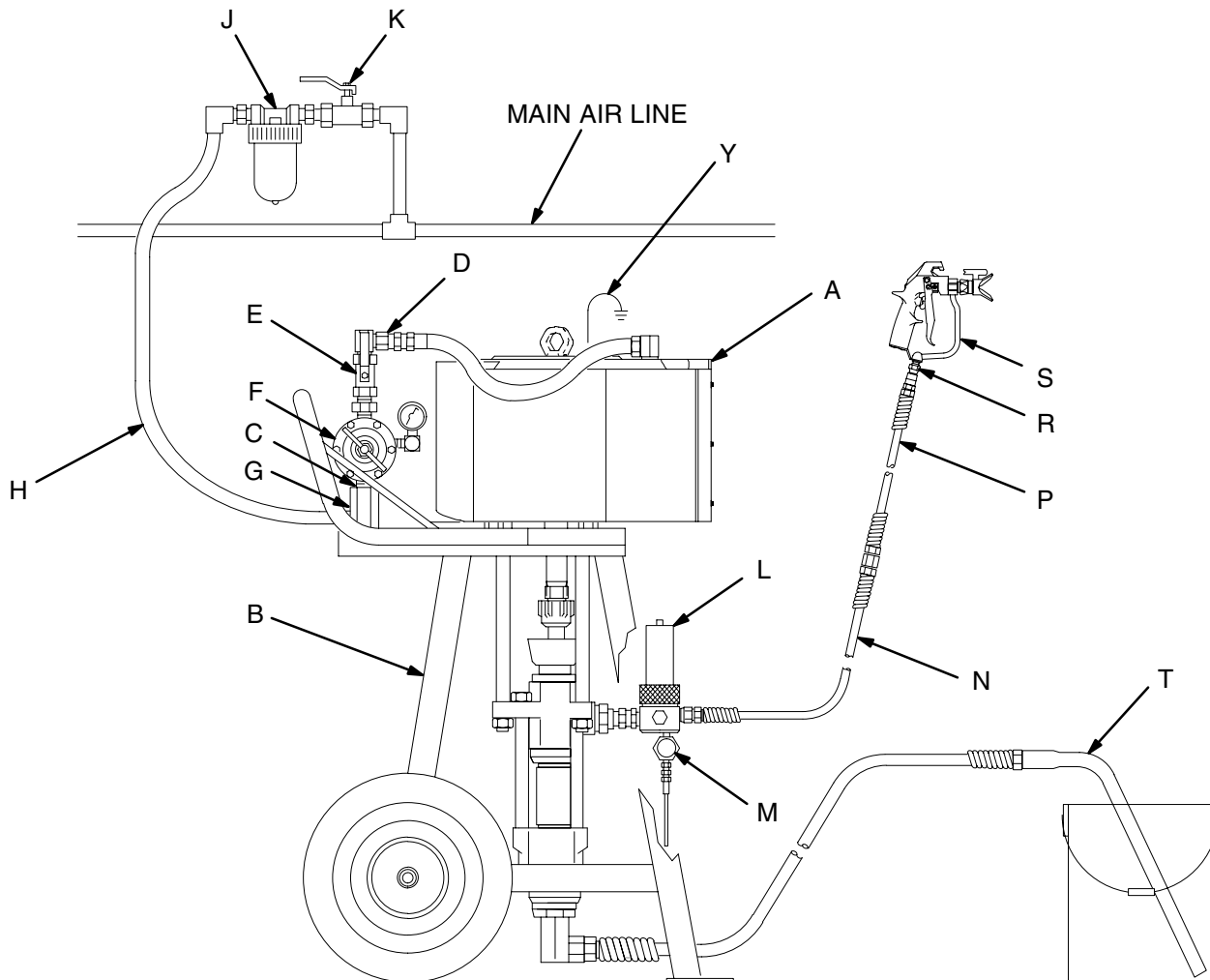

Fig. 2

Installation

ASSEMBLE THE PUMP

Assemble the displacement pump (105) to the air motor (101) as instructed on pages 12–13.

SYSTEM ACCESSORIES

WARNING

A bleed-type master air valve (E) and a fluid drain valve (M) are required in your system. These accessories help reduce the risk of serious injury, including fluid injection and splashing of fluid in the eyes or on the skin, and injury from moving parts if you are adjusting or repairing the pump.

The bleed-type master air valve relieves air trapped between this valve and the pump after the air is shut off. Trapped air can cause the pump to cycle unexpectedly. Locate the valve close to the pump. Order Part No. 112730.

The fluid drain valve assists in relieving fluid pressure in the displacement pump, hose, and gun. Triggering the gun to relieve pressure may not be sufficient. Order Part No. 224774.

Air and Fluid Hoses

Be sure all air hoses (H) and fluid hoses (N and P) are properly sized and pressure-rated for your system. Use only electrically conductive hoses. Fluid hoses must have spring guards on both ends. Use a whip hose (P) and a swivel (R) between the main fluid hose (N) and the gun (S) to allow freer gun movement.

Mounting Accessories

Mount the pump (A) to suit the type of installation planned. Fig. 2 illustrates a cart-mounted system. Pump dimensions and the mounting hole layout are shown on page 23.

If you are using a floor stand, refer to its separate manual for installation and operation instructions.

Air Line Accessories

Install the following accessories in the locations shown in Fig. 2, using adapters as necessary:

- **An air line lubricator (D)** provides automatic air motor lubrication.
- **A bleed-type master air valve (E)** is required in your system to relieve air trapped between it and the air motor when the valve is closed (see the **WARNING** at left). Be sure the bleed valve is easily accessible from the pump, and is located **downstream** from the air regulator. Order Part No. 112730.
- **An air regulator (F)** controls pump speed and outlet pressure by adjusting the air pressure to the pump. Locate the regulator close to the pump, but **upstream** from the bleed-type master air valve.
- **A pump runaway valve (C)** senses when the pump is running too fast and automatically shuts off the air to the motor. A pump which runs too fast can be seriously damaged.
- **An air manifold (G)** has a 1 in. npt air inlet. It mounts to the pump support bracket, and provides ports for connecting lines to air-powered accessories.
- **An air line filter (J)** removes harmful dirt and moisture from the compressed air supply.
- **A second bleed-type air valve (K)** isolates the air line accessories for servicing. Locate upstream from all other air line accessories.

Fluid Line Accessories

Install the following accessories in the locations shown in Fig. 2, using adapters as necessary:

- **A fluid filter (L)** with a 60 mesh (250 micron) stainless steel element, to filter particles from the fluid as it leaves the pump. It includes a **fluid drain valve (M)**, which is required in your system to relieve fluid pressure in the hose and gun (see the **WARNING** at left).
- **A gun (S)** dispenses the fluid. The gun shown in Fig. 2 is an airless spray gun for light to medium viscosity fluids.
- **A gun swivel (R)** allows freer gun movement.
- **A suction kit (T)** allows the pump to draw fluid from a 19 liter (5 gallon) pail.

Operation/Maintenance

Pressure Relief Procedure

WARNING



SKIN INJECTION HAZARD

Fluid under high pressure can be injected through the skin and cause serious injury. To reduce the risk of an injury from injection, splashing fluid, or moving parts, follow the **Pressure Relief Procedure** whenever you:

- are instructed to relieve the pressure,
- stop spraying/dispensing,
- check or service any of the system equipment,
- or install or clean the spray tip/nozzle.

1. Lock the spray gun/dispensing valve trigger safety.
2. Shut off the air supply to the pump.
3. Close the bleed-type master air valve (required in your system).
4. Unlock the gun/valve trigger safety.
5. Hold a metal part of the gun/valve firmly to the side of a grounded metal pail, and trigger the gun/valve to relieve pressure.
6. Lock the gun/valve trigger safety.
7. Open the drain valve (required in your system), having a container ready to catch the drainage.
8. Leave the drain valve open until you are ready to spray/dispense again.

If you suspect that the spray tip/nozzle or hose is completely clogged, or that pressure has not been fully relieved after following the steps above, very slowly loosen the tip guard retaining nut or hose end coupling and relieve pressure gradually, then loosen completely. Now clear the tip/nozzle or hose.

Packing Nut/Wet Cup

Before starting, fill the packing nut (2) 1/3 full with Graco Throat Seal Liquid (TSL) or compatible solvent. See Fig. 3.

The packing nut is torqued at the factory and is ready for operation. If it becomes loose and there is leaking from the throat packings, you must first follow the **Pressure Relief Procedure Warning** above, then torque the nut to 129–142 N.m (95–105 ft-lb) using the supplied wrench (104). Do this whenever necessary. Do not overtighten the packing nut.

FLUSHING THE PUMP

The pump is tested with lightweight oil, which is left in to protect the pump parts. If the fluid you are using may be contaminated by the oil, flush it out with a compatible solvent before using the pump.

WARNING

For your safety, read the warning section, **FIRE AND EXPLOSION HAZARD** on page 4 before flushing, and follow all recommendations given there.

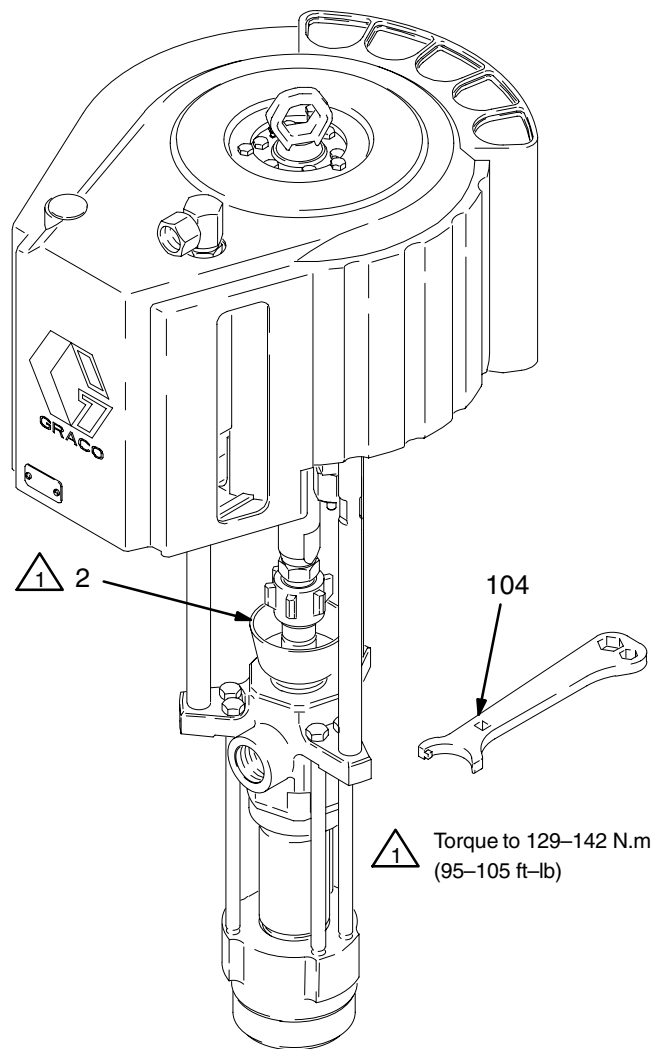

Fig. 3

Operation/Maintenance

Starting and Adjusting the Pump

1. Refer to Fig. 2 on page 6. Connect the suction kit (T) to the pump's fluid inlet, and place the tube into the fluid supply.
2. Be sure the air regulator (F) is closed. Then open the pump's bleed-type master air valve (E). Hold a metal part of the spray gun (S) firmly to the side of a grounded metal pail and hold the trigger open. Now slowly open the air regulator until the pump starts.
3. Cycle the pump slowly until all air is pushed out and the pump and hoses are fully primed. Release the gun trigger and engage the safety latch. The pump should stall against pressure when the trigger is released.
4. If the pump fails to prime properly, open the drain valve (M). Use the drain valve as a priming valve until the fluid flows from the valve. See Fig. 2. Close the drain valve.

NOTE: When changing fluid containers with the hose and gun already primed, open the drain valve (M), to assist in priming the pump and venting air before it enters the hose. Close the drain valve when all air has been eliminated.

5. With the pump and lines primed, and with adequate air pressure and volume supplied, the pump will start and stop as the gun is opened and closed. In a circulating system, the pump will speed up or slow down on demand, until the air supply is shut off.
6. Use the air regulator to control the pump speed and the fluid pressure. Always use the lowest air pressure necessary to get the desired results. Higher pressures cause premature tip and pump wear.

WARNING

To reduce the risk of overpressurizing your system, which could result in component rupture and cause serious injury, never exceed the specified Maximum Incoming Air Pressure to the pump (see the **Technical Data** on page 21).

7. Never allow the pump to run dry of the fluid being pumped. A dry pump will quickly accelerate to a high speed, possibly damaging itself. A pump runaway valve (C), which shuts off the air supply to the pump if the pump accelerates beyond the pre-set speed, is available. See Fig. 2 on page 6. If your pump accelerates quickly, or is running too fast, stop it immediately and check the fluid supply. If the supply container is empty and air has been pumped into the lines, refill the container and prime the pump and the lines with fluid, or flush and leave it filled with a compatible solvent. Be sure to eliminate all air from the fluid system.

Shutdown and Care of the Pump

WARNING

To reduce the risk of serious injury whenever you are instructed to relieve pressure, always follow the **Pressure Relief Procedure** on page 8.

For overnight shutdown, **relieve the pressure**. Stop the pump at the bottom of its stroke to prevent fluid from drying on the exposed displacement rod and damaging the throat packings.

Always flush the pump before the fluid dries on the displacement rod. Never leave water or water-based fluid in the pump overnight. First, flush with water or a compatible solvent, then with mineral spirits. Relieve the pressure, but leave the mineral spirits in the pump to protect the parts from corrosion.

Troubleshooting Chart

WARNING

To reduce the risk of serious injury whenever you are instructed to relieve pressure, always follow the **Pressure Relief Procedure** on page 8.

Before servicing this equipment always make sure to **Relieve the Pressure**.

Check all possible problems and solutions before disassembling the pump.

PROBLEM	CAUSE	SOLUTION
Pump fails to operate.	Restricted line or inadequate air supply; closed or clogged valves.	Clear; increase air supply. Check that valves are open.
	Obstructed fluid hose or gun/valve; fluid hose ID is too small.	Open, clear*; use hose with larger ID. Hose must be rated for 510 bar (7400 psi).
	Fluid dried on the displacement rod.	Clean; always stop pump at bottom of stroke; keep wet-cup 1/3 filled with compatible solvent.
	Dirty, worn, or damaged motor parts.	Clean or repair; see separate motor manual.
Pump operates, but output low on both strokes.	Restricted line or inadequate air supply; closed or clogged valves.	Clear; increase air supply. Check that valves are open.
	Obstructed fluid hose or gun/valve; fluid hose ID is too small.	Open, clear*; use hose with larger ID. Hose must be rated for 51.0 MPa, 510 bar (7400 psi).
	Worn packings in displacement pump.	Replace packings.
Pump operates, but output low on down-stroke.	Held open or worn intake valve.	Clear valve; service.
Pump operates, but output low on upstroke.	Held open or worn piston valve or packings.	Clear valve; replace packings.
Erratic or accelerated pump speed.	Exhausted fluid supply.	Refill and prime.
	Held open or worn piston valve or packings.	Clear valve; replace packings.
	Held open or worn intake valve.	Clear valve; service.

* To determine if the fluid hose or gun is obstructed, **relieve the pressure**. Disconnect the fluid hose and place a container at the pump fluid outlet to catch any fluid. Turn on the air just enough to start the pump. If the pump starts when the air is turned on, the obstruction is in the fluid hose or gun.

NOTE: If you experience air motor icing, call your Graco distributor.

Service

WARNING

To reduce the risk of serious injury whenever you are instructed to relieve pressure, always follow the **Pressure Relief Procedure** on page 8.

REQUIRED TOOLS

- Set of adjustable wrenches
- 15/16 in. (or 23 mm) socket wrench
- Large pipe wrench
- Torque wrench
- Rubber mallet
- O-ring pick
- Large vise
- Thread lubricant
- Thread sealant
- Loctite® 2760™ or equivalent

DISCONNECTING THE DISPLACEMENT PUMP

1. Flush the pump, if possible. Stop the pump at the bottom of its stroke and **relieve the pressure**.
2. Disconnect the air hose and fluid hose.
3. Disconnect the displacement pump (105) from the motor (101) as follows. Be sure to note the relative position of the pump's fluid outlet (U) to the air inlet (V) of the motor. If the motor does not require servicing, leave it attached to its mounting.

CAUTION

Be sure to use at least two people when lifting, moving, or disconnecting the pump. This pump is too heavy for one person. If you are disconnecting the displacement pump from a motor which is still mounted (for example, on a wall bracket), be sure to support the displacement pump while it is being disconnected, to prevent it from falling and causing injury or property damage. Do this by securely bracing the pump, or by having at least two people hold it while another disconnects it.

If the pump is mounted on a cart, slowly tip the cart backward until the handle rests on the ground, then disconnect the displacement pump.

4. Using an adjustable wrench (or hammer and punch), unscrew the coupling nut (103) from the connecting rod adapter (102). Remove the coupling collars (108). Take care not to lose or drop them. See Fig. 4.

5. Hold the tie rod flats with a wrench to keep the rods from turning. Unscrew the nuts (106) from the tie rods (107). Carefully remove the displacement pump (105) from the motor (101).
6. Refer to page 14 for displacement pump service. To service the air motor, refer to the separate motor manual, supplied.

RECONNECTING THE DISPLACEMENT PUMP

1. Ensure that the rod adapter (102) has not loosened during maintenance. Proper torque is necessary to prevent the rod adapter from loosening during the pump operation.

If the rod adapter (102) has loosened, remove it and apply Loctite® 2760™ (or equivalent) to the rod adapter and air motor piston threads.

Screw the adapter (102) into the air motor shaft. Hold the motor shaft flats with a wrench to keep it from turning, and torque the adapter to 312–340 N.m (230–250 ft-lb). See Fig. 4.

2. Screw the tie rods (107) into the base of the air motor (101). Using a wrench on the tie rod flats, torque to 129–142 N.m (95–105 ft-lb).
3. Make sure the coupling nut (103) and the coupling collars (108) are in place on the displacement rod (1).
4. Use at least two people to hold the displacement pump while another reconnects it to the motor (see the **CAUTION** at left). Orient the pump's fluid outlet (U) to the air inlet (V) as was noted in step 3 under **Disconnecting the Displacement Pump**. Position the displacement pump (105) on the tie rods (107).
5. Screw the nuts (106) onto the tie rods (107) and torque to 129–142 N.m (95–105 ft-lb).
6. Screw the coupling nut (103) onto the connecting rod adapter (102) loosely. Hold the connecting rod adapter flats with a wrench to keep it from turning. Use an adjustable wrench to tighten the coupling nut. Torque to 312–340 N.m (230–250 ft-lb).
7. Reconnect all hoses. Reconnect the ground wire if it was disconnected. Fill the packing nut (2) 1/3 full of Graco Throat Seal Liquid or compatible solvent.
8. Turn on the air supply. Run the pump slowly to ensure that it is operating properly.
9. Before returning the pump to production, **relieve the pressure**. Retorque the packing nut (2) to 129–142 N.m (95–105 ft-lb).

Service

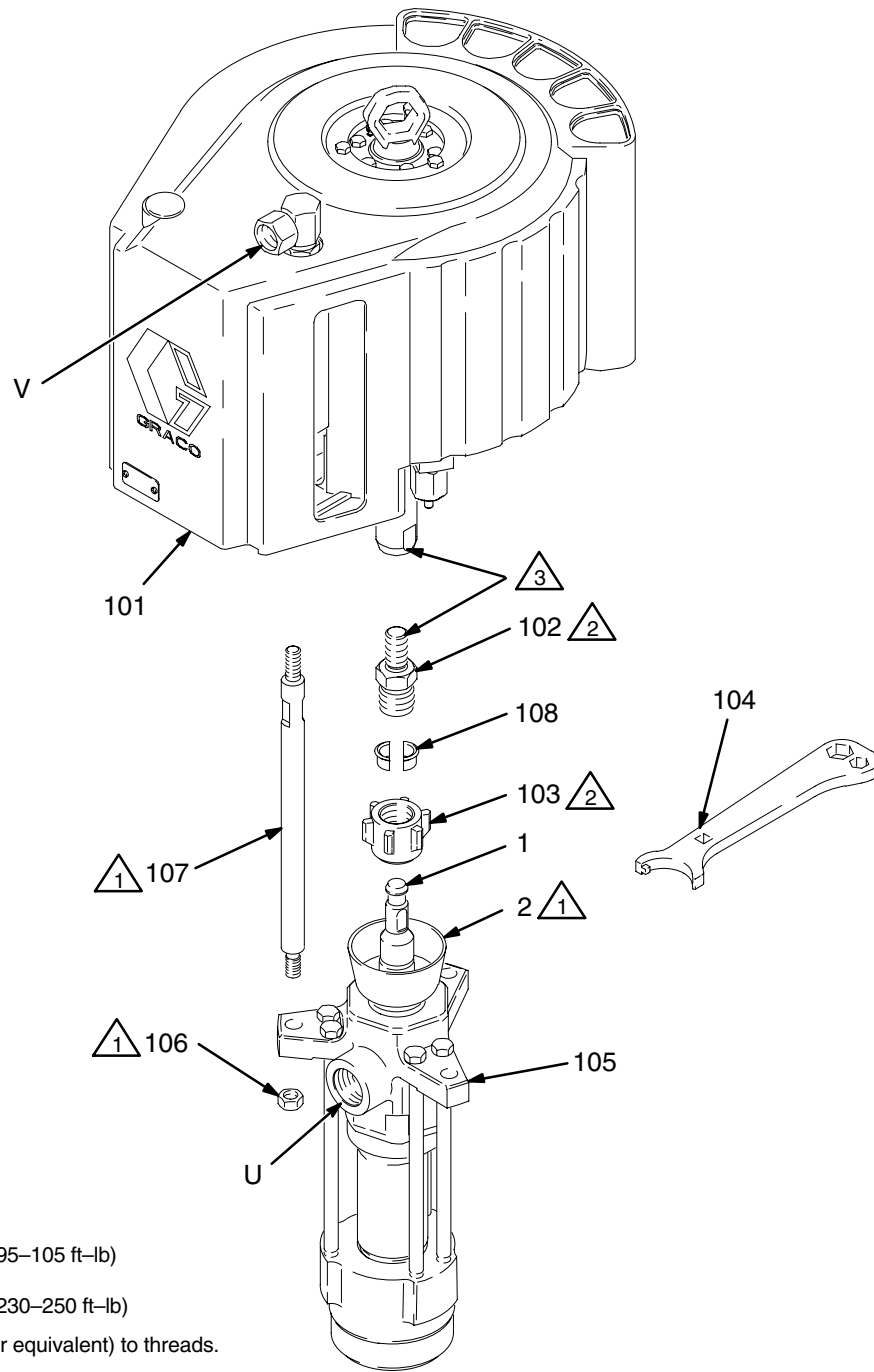

- 1 Torque to 129–142 N.m (95–105 ft-lb)
- 2 Torque to 312–340 N.m (230–250 ft-lb)
- 3 Apply Loctite® 2760™ (or equivalent) to threads.

Fig. 4

9592A

Service

DISPLACEMENT PUMP SERVICE

Disassembly

When disassembling the pump, lay out all the removed parts in sequence, to ease reassembly.

NOTE: Repair Kit 237166 is available. For the best results, use all the new parts in the kit. Kit parts are marked with an asterisk, for example (3*). Kits to convert the pump to different packing materials are also available. Refer to page 20.

1. Place the pump lengthwise in a large vise, with the jaws on the outlet housing (9) as shown in Fig. 5. Using the supplied wrench (104), loosen, but do not remove, the packing nut (2).
2. Using a pipe wrench, unscrew the intake valve (17) from the intake housing (16). Be careful to catch the intake ball (15) as you remove the intake valve, so that it doesn't fall and suffer damage. Remove the o-ring (28) from the intake valve. Inspect the ball and the seat (D) of the intake valve for wear or damage. See Fig. 5.
3. Stand the pump upright in the vise. Remove the six long cap screws (29), using a 15/16 in. (or 23 mm) socket wrench. See Fig. 8.
4. Lift the outlet housing (9) straight up off the pump. Be careful not to scratch the displacement rod (1) while removing the housing. See Fig. 6.

5. Lift the cylinder (11), displacement rod (1), and piston assembly off the intake housing (16). Remove the ball guide (27) from the intake housing, and inspect the guide surfaces. See Fig. 6.
6. Using a rubber mallet, drive the displacement rod (1) and piston assembly out the bottom of the cylinder (11) until the piston comes free. Pull the rod and piston from the cylinder, being careful not to scratch the parts.

CAUTION

To reduce the possibility of costly damage to the rod (1) and cylinder (11), always use a rubber mallet to drive the rod out of the cylinder. Never use a hammer to drive the rod.

7. Shine a light into the cylinder (11) to inspect the inner surface for scoring or wear. Remove the o-rings (10) from the cylinder.
8. Place the flats of the piston seat housing (14) in a vise, as shown in Fig. 7. Using an adjustable wrench, unscrew the piston ball housing (12) from the piston seat housing. Be careful to catch the piston ball (13) as you separate the piston seat housing and ball housing, so that it doesn't fall and suffer damage.

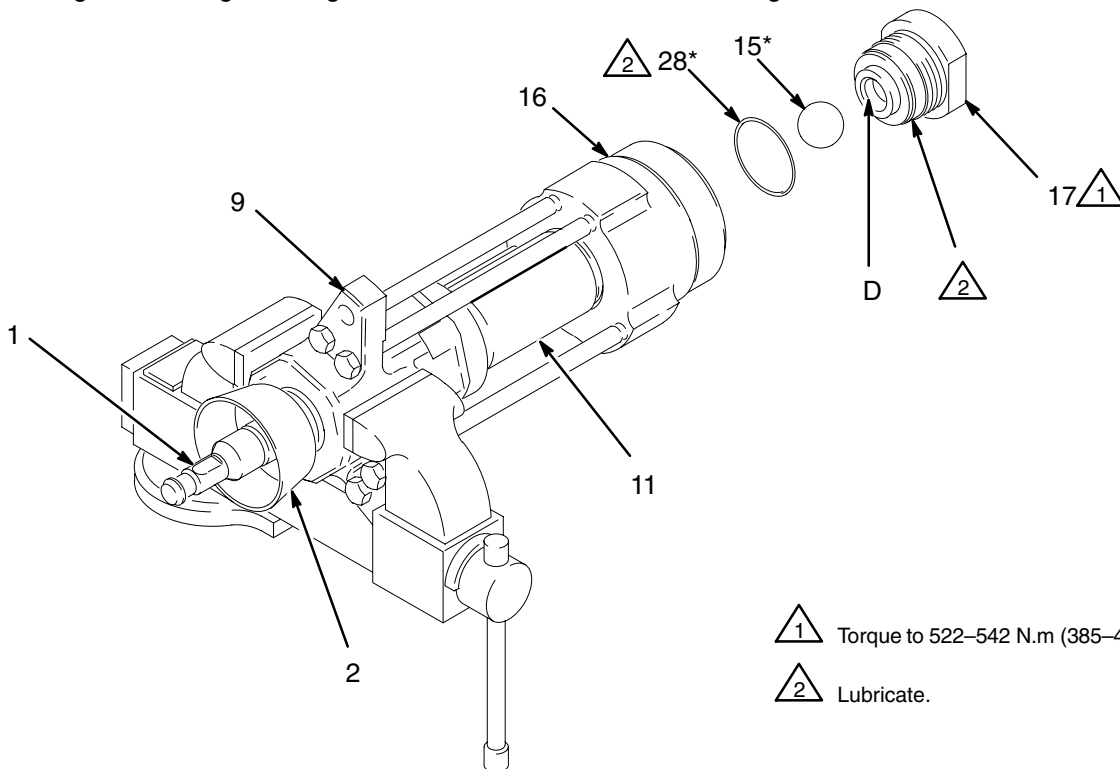

Fig. 5
14 308357

Service

9. Examine the displacement rod (1) for scratches or other damage. **Only if the rod needs replacement**, unscrew it from the piston ball housing (12), using an adjustable wrench on the flats of the rod.
10. Remove and inspect the glands and v-packings (P) from the piston seat housing (14). Inspect the ball (13), and the seat (E) and guides (F) on the housing for wear or damage. See Fig. 8.
11. Unscrew the packing nut (2) from the outlet housing (9). Remove and inspect the glands and v-packings (T).
12. Clean all parts with a compatible solvent and inspect them for wear or damage.

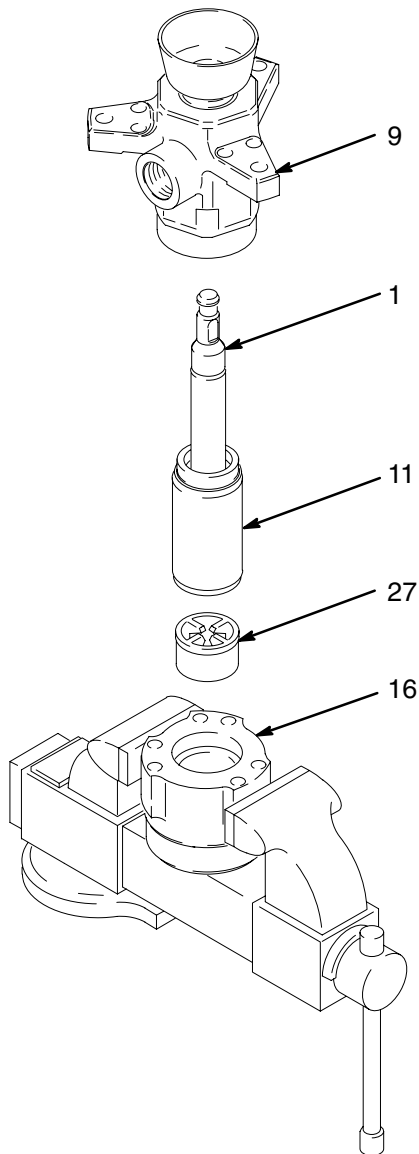
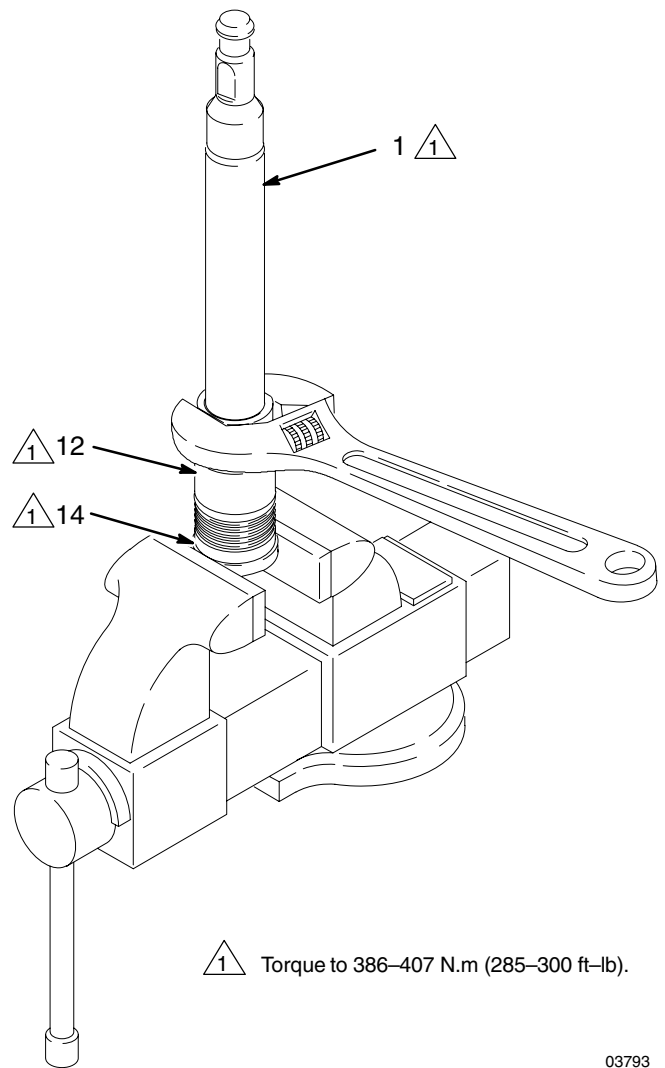

Fig. 6



1 Torque to 386–407 N.m (285–300 ft–lb).

Fig. 7

Service

Reassembly

1. *If it was necessary to remove the piston ball housing (12) from the displacement rod (1), clean the threads of the rod and the ball housing, and apply thread sealant. Screw the ball housing onto the rod, hand tight. Place the flats of the piston ball housing in a vise and torque the rod to 386–407 N.m (285–300 ft–lb). See Fig. 8.*
2. Place the piston packings on the piston seat housing (14) in the following order, **with the lips of the v-packings facing up**: the female gland (4*), one PTFE v-packing (3*), four leather v-packings (5*), and the male gland (6*). See the Piston Packing Stack Detail in Fig. 8.

NOTE: To convert the pump to a different packing material, see page 20.











3. Place the flats of the piston seat housing (14) in a vise. Place the ball (13*) on the piston seat (E). Screw the piston ball housing (12) onto the piston seat housing hand tight, then torque to 386–407 N.m (285–300 ft–lb). See Fig. 7.
4. Lubricate the throat packings and place them in the outlet housing (9) in the following order, **with the lips of the v-packings facing down**: the male gland (6*), four leather v-packings (5*), one PTFE v-packing (3*), and the female gland (4*). See the Throat Packing Stack Detail in Fig. 8.

NOTE: To convert the pump to a different packing material, see page 20.

5. Lubricate the threads of the packing nut (2), and loosely install it in the outlet housing (9).
6. Lubricate the piston packings. Slide the displacement rod (1) and piston assembly down into the cylinder (11). The cylinder is symmetrical, so either end may face up. Use a rubber mallet to drive the rod into the cylinder, until the piston seat housing (14) is near the bottom of the cylinder.

7. Place the intake ball guide (27) in the intake housing (16). Set the intake housing in the vise, facing upright. See Fig. 6.
8. Install the o-ring (10*) on the bottom of the cylinder (11). Lubricate the o-ring. Place the cylinder on the intake housing (16). Tap the top of the displacement rod (1) with a rubber mallet, to seat the cylinder.
9. Install the o-ring (10*) on the top of the cylinder (11). Lubricate the o-ring. Set the outlet housing (9) on the cylinder.
10. Apply thread lubricant to the six long cap screws (29). Install them through the outlet housing (9) and thread them loosely into the intake housing (16). Tighten the screws oppositely and evenly with a socket wrench, then torque to 244–264 N.m (180–195 ft–lb). See Fig. 8.
11. Place the pump lengthwise in the vise, with the jaws on the outlet housing (9) as shown in Fig. 5.
12. Install the o-ring (28*) on the intake valve (17). Lubricate the o-ring and the threads of the intake valve. Place the intake ball (15*) in the intake housing (16), then screw the intake valve into the intake housing handtight.
13. Using a pipe wrench, torque the intake valve (17) to 522–542 N.m (385–400 ft–lb). See Fig. 5.
14. Torque the packing nut (2) to 129–142 N.m (95–105 ft–lb).
15. Reconnect the displacement pump to the air motor as explained on page 12.

Service

-  Torque to 129–142 N.m (95–105 ft-lb).
-  Torque to 522–542 N.m (385–400 ft-lb).
-  Torque to 386–407 N.m (285–300 ft-lb).
-  Lubricate.
-  Apply thread sealant.
-  Lips face up.
-  Lips face down.
-  See Throat Packing Detail at left.
-  See Piston Packing Detail at left.
-  Torque to 244–264 N.m (180–195 ft-lb).

Throat Packing Stack Detail

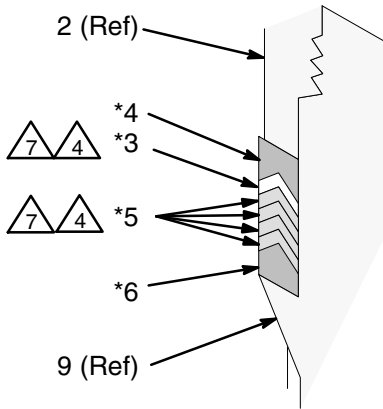

Piston Packing Stack Detail

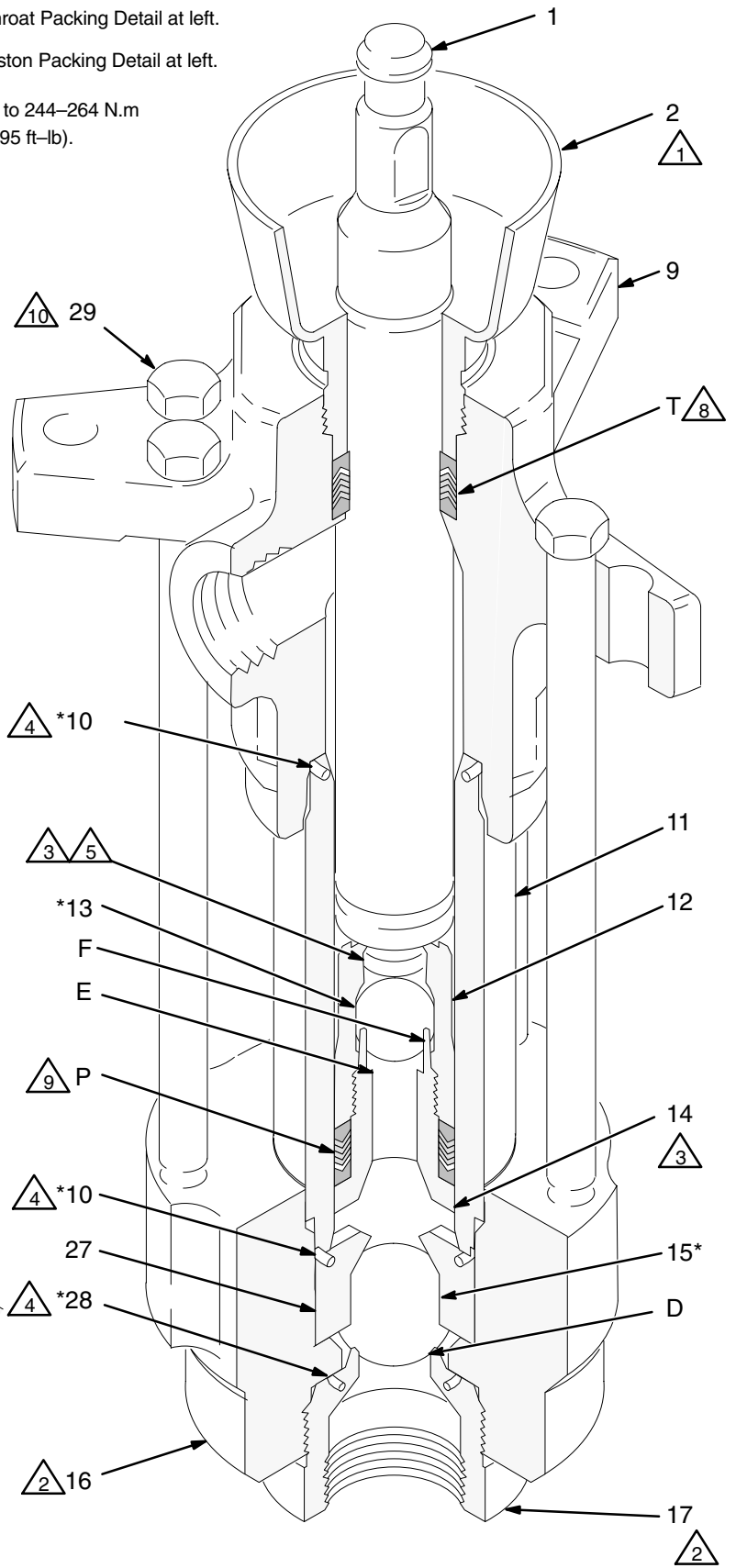
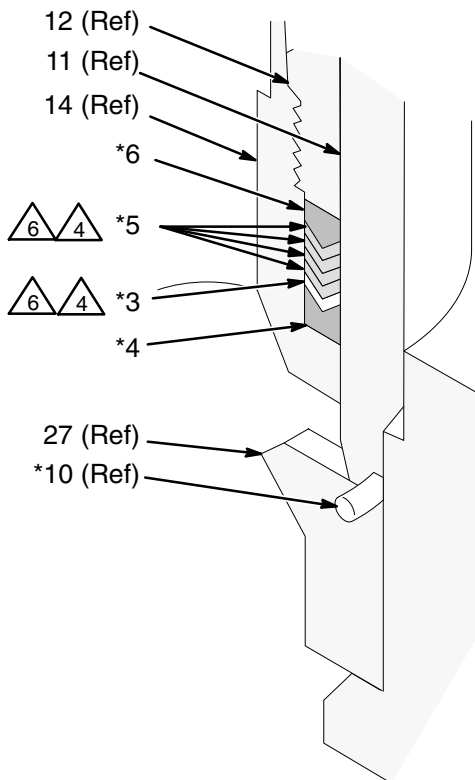

Fig. 8

03984

Parts

Part No. 236932 Pump, Series A 74:1 Ratio, with Premier Air Motor

Ref. No.	Part No.	Description	Qty.
101	222800	AIR MOTOR, Premier See 308213 for parts	1
102†	184583	ADAPTER, connecting rod	1
103†	184098	NUT, coupling	1
104†	112887	WRENCH, spanner	1
105	236478	PUMP, displacement See page 19 for parts	1
106†	106166	NUT, hex; M16 x 2.0	3
107†	184382	ROD, tie; 380 mm (14.96 in.) shoulder to shoulder	3
108†	184129	COLLAR, coupling	2

† These parts are included in Connection Kit 235416.

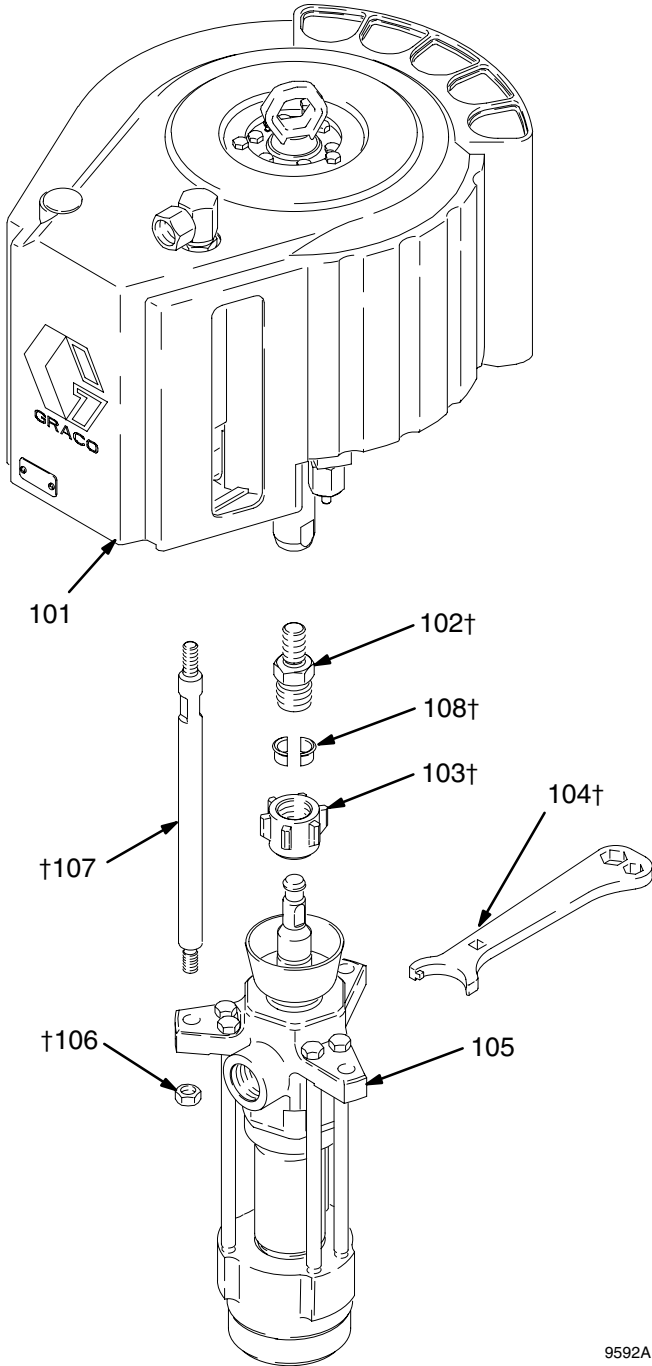

9592A

Parts

Displacement Pump 236478, Series A

Ref No.	Part No.	Description	Qty	Ref No.	Part No.	Description	Qty
1	189317	ROD, displacement; stainless steel	1	15*	108001	BALL, intake; stainless steel; 1.5 in. (38.1 mm) dia.	1
2	222995	PACKING NUT; carbon steel	1	16	190218	HOUSING, intake; ductile iron	1
8▲	172479	TAG, warning (not shown)	1	17	237495	VALVE, intake; ductile iron w/tungsten carbide seat	1
9	237183	HOUSING, outlet; ductile iron	1	20	101754	PLUG, pipe, socket hd; 3/8 npt	1
10*	109499	SEAL; PTFE	2	27	190228	GUIDE, intake ball; carbon steel	1
11	190221	CYLINDER; stainless steel	1	28*	164782	O-RING; PTFE	1
12	184513	HOUSING, ball, piston; carbon steel	1	29	112921	SCREW, cap, hex hd; 5/8-11 unc-2a; 10.5 in. (266.7 mm) long	6
13*	100279	BALL, piston; chrome steel; 0.875 in. (22.2 mm) dia.	1				
14	222951	HOUSING, seat, piston valve; stainless steel w/tungsten carbide seat	1				

* These parts are included in Standard Repair Kit 237166 and Conversion Kits 237167 and 237168, which may be purchased separately. See page 20.

▲ Replacement Danger and Warning labels, tags and cards are available at no cost.

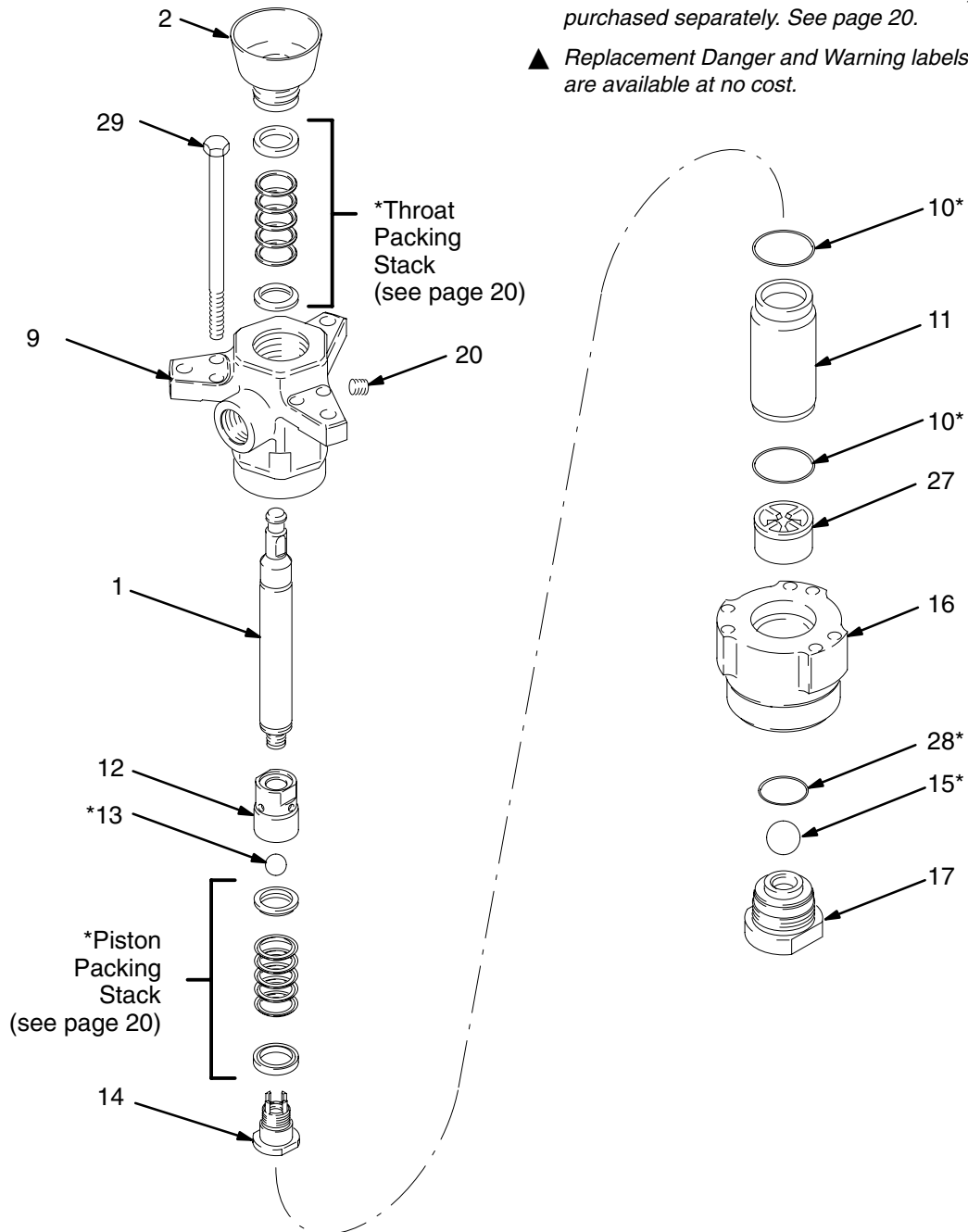

Repair Kits

Standard Repair Kit 237166 (Leather Packings and PTFE Backup)

Ref No.	Part No.	Description	Qty
3*	109306	V-PACKING; PTFE	2
4*	184201	GLAND, female; carbon steel	2
5*	184306	V-PACKING; leather	8
6*	184251	GLAND, male; carbon steel	2

Kit also includes items 10, 13, 15, and 28 (see page 19).

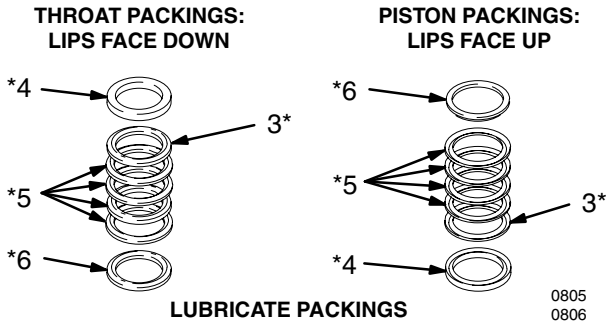

Packing Conversion Kit 237168 (UHMWPE and Leather Packings)

Ref No.	Part No.	Description	Qty
3*	109256	V-PACKING; UHMWPE	6
4*	184201	GLAND, female; carbon steel	2
5*	184306	V-PACKING; leather	4
6*	184251	GLAND, male; carbon steel	2

Kit also includes items 10, 13, 15, and 28 (see page 19).

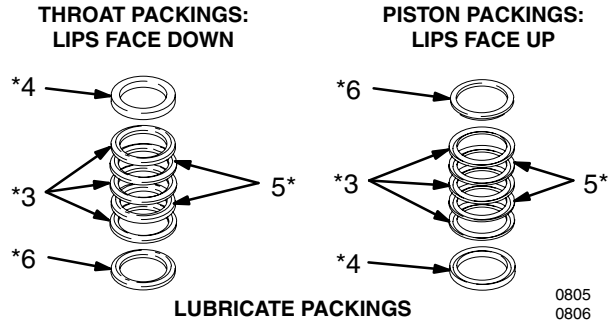

Packing Conversion Kit 237167 (PTFE Packings)

Ref No.	Part No.	Description	Qty
3*	109306	V-PACKING; PTFE	10
4*	184201	GLAND, female; carbon steel	2
6*	184251	GLAND, male; carbon steel	2

Kit also includes items 10, 13, 15, and 28 (see page 19).

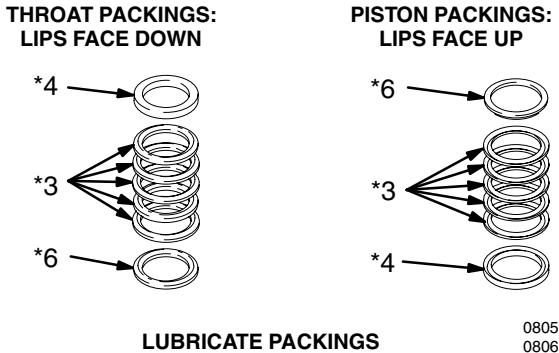

Technical Data

(MODEL 236932 PREMIER PUMP)

Category	Data
Ratio	74:1
Maximum fluid working pressure	500 bar (7252 psi)
Maximum air input pressure	6.7 bar (97 psi)
Pump cycles per 3.8 liters (1 gal.)	14
Maximum flow at 60 cycles/min.	15.9 liters/min (4.2 gpm)
Air motor piston effective area	800 cm ² (124 in. ²)
Stroke length	120 mm (4.75 in.)
Displacement pump effective area	11 cm ² (2.79 in. ²)
Maximum pump operating temperature (ambient and fluid)	82°C (180°F)
Air inlet size	3/4 npsm(f)
Fluid inlet size	2 in. npt(f)
Fluid outlet size	1 in. npt(f)
Weight	approx. 109 kg (240 lb)
Wetted parts	Carbon Steel; Chrome Steel, Zinc and Nickel Plating; 440 and 17-4 PH Grades of Stainless Steel; Alloy Steel; Tungsten Carbide; Ductile Iron; PTFE; Glass-Filled PTFE; Leather

Sound Pressure Levels (dBa)

(measured at 1 meter from unit)

Air Motor	Input Air Pressures at 15 cycles per minute			
	0.28 MPa, 2.8 bar (40 psi)	0.48 MPa, 4.8 bar (70 psi)	0.63 MPa, 6.3 bar (90 psi)	0.7 MPa, 7 bar (100 psi)
Premier	82.5	82.4	83.2	83.0

Sound Power Levels (dBa)

(tested in accordance with ISO 9614-2)

Air Motor	Input Air Pressures at 15 cycles per minute			
	0.28 MPa, 2.8 bar (40 psi)	0.48 MPa, 4.8 bar (70 psi)	0.63 MPa, 6.3 bar (90 psi)	0.7 MPa, 7 bar (100 psi)
Premier	90.6	90.6	93.0	95.9

Technical Data

(MODEL 236932 PREMIER PUMP)

Performance Charts: Premier Pumps

To find Fluid Outlet Pressure (psi/MPa/bar) at a specific fluid flow (lpm/gpm) and operating air pressure (psi/MPa/bar):

1. Locate desired flow along bottom of chart.
2. Follow vertical line up to intersection with selected fluid outlet pressure curve (black). Follow left to scale to read fluid outlet pressure.

To find Pump Air Consumption (m³/min. or scfm) at a specific fluid flow (lpm/gpm) and air pressure (psi/MPa/bar):

1. Locate desired flow along bottom of chart.
2. Read vertical line up to intersection with selected air consumption curve (dashes). Follow left to scale to read air consumption.

- A 0.7 MPa, 7 bar (100 psi) air pressure
- B 500 kPa, 4.9 bar (70 psi) air pressure
- C 300 kPa, 2.8 bar (40 psi) air pressure

Test Fluid: No. 10 Weight Oil

Fluid Outlet Pressure

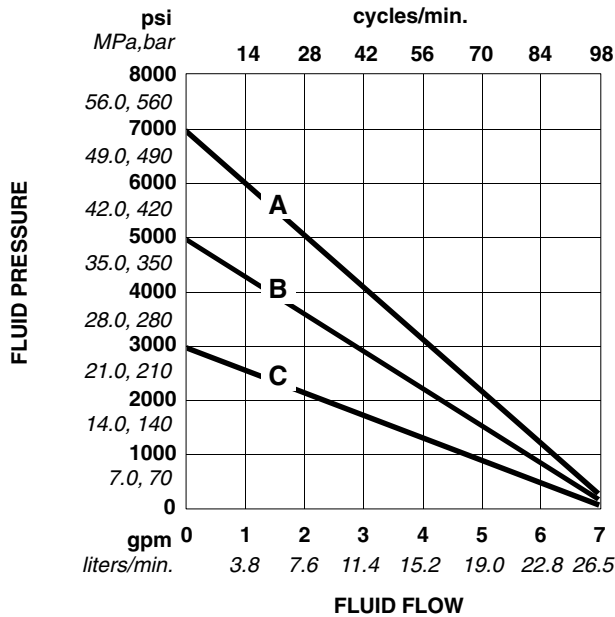

Air Consumption

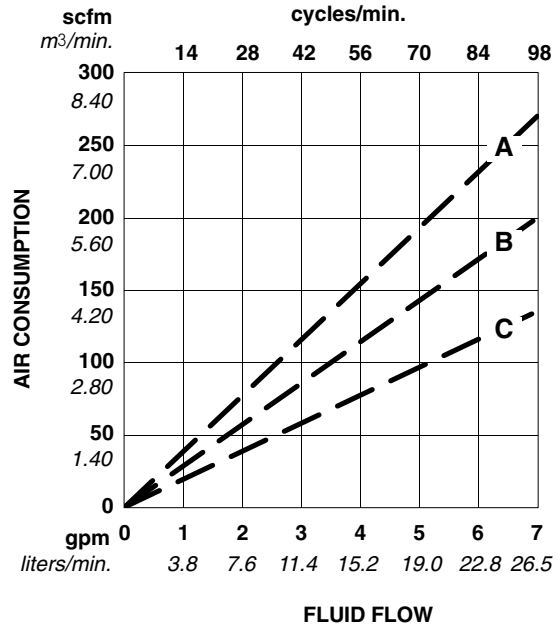

Dimensions

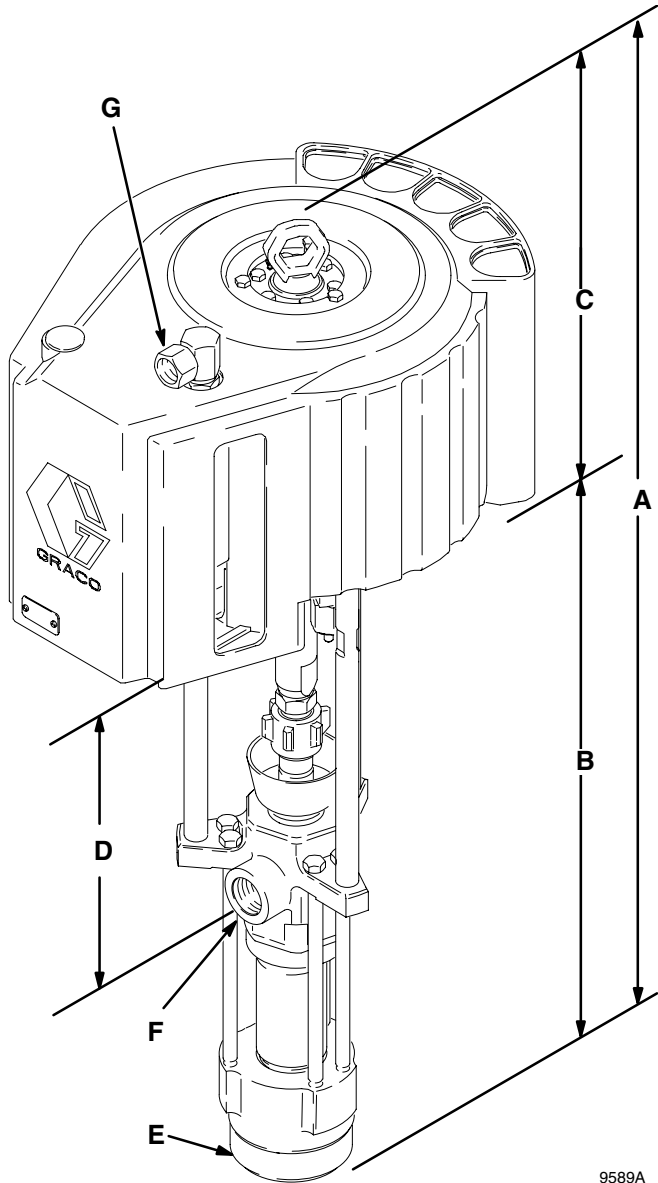

9589A

Mounting Hole Layout

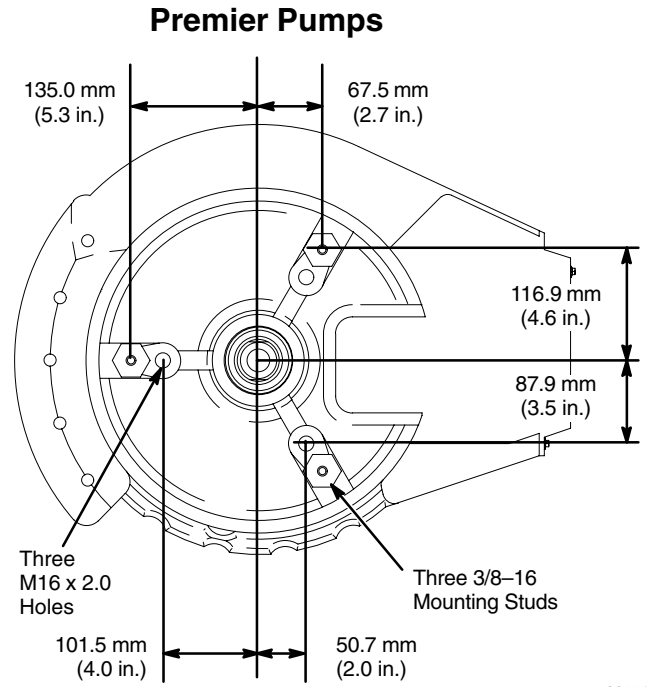

9655A

Pump Model	A	B	C	D	E	F	G
236932	1146.9 mm (45.15 in.)	746.0 mm (29.37 in.)	400.9 mm (15.78 in.)	413.0 mm (16.26 in.)	2 in. npt(f)	1 in. npt(f)	3/4 npsm(f)

Graco Standard Warranty

Graco warrants all equipment manufactured by Graco and bearing its name to be free from defects in material and workmanship on the date of sale by an authorized Graco distributor to the original purchaser for use. With the exception of any special, extended, or limited warranty published by Graco, Graco will, for a period of twelve months from the date of sale, repair or replace any part of the equipment determined by Graco to be defective. This warranty applies only when the equipment is installed, operated and maintained in accordance with Graco's written recommendations.

This warranty does not cover, and Graco shall not be liable for general wear and tear, or any malfunction, damage or wear caused by faulty installation, misapplication, abrasion, corrosion, inadequate or improper maintenance, negligence, accident, tampering, or substitution of non-Graco component parts. Nor shall Graco be liable for malfunction, damage or wear caused by the incompatibility of Graco equipment with structures, accessories, equipment or materials not supplied by Graco, or the improper design, manufacture, installation, operation or maintenance of structures, accessories, equipment or materials not supplied by Graco.

This warranty is conditioned upon the prepaid return of the equipment claimed to be defective to an authorized Graco distributor for verification of the claimed defect. If the claimed defect is verified, Graco will repair or replace free of charge any defective parts. The equipment will be returned to the original purchaser transportation prepaid. If inspection of the equipment does not disclose any defect in material or workmanship, repairs will be made at a reasonable charge, which charges may include the costs of parts, labor, and transportation.

THIS WARRANTY IS EXCLUSIVE, AND IS IN LIEU OF ANY OTHER WARRANTIES, EXPRESS OR IMPLIED, INCLUDING BUT NOT LIMITED TO WARRANTY OF MERCHANTABILITY OR WARRANTY OF FITNESS FOR A PARTICULAR PURPOSE.

Graco's sole obligation and buyer's sole remedy for any breach of warranty shall be as set forth above. The buyer agrees that no other remedy (including, but not limited to, incidental or consequential damages for lost profits, lost sales, injury to person or property, or any other incidental or consequential loss) shall be available. Any action for breach of warranty must be brought within two (2) years of the date of sale.

Graco makes no warranty, and disclaims all implied warranties of merchantability and fitness for a particular purpose in connection with accessories, equipment, materials or components sold but not manufactured by Graco. These items sold, but not manufactured by Graco (such as electric motors, switches, hose, etc.), are subject to the warranty, if any, of their manufacturer. Graco will provide purchaser with reasonable assistance in making any claim for breach of these warranties.

In no event will Graco be liable for indirect, incidental, special or consequential damages resulting from Graco supplying equipment hereunder, or the furnishing, performance, or use of any products or other goods sold hereto, whether due to a breach of contract, breach of warranty, the negligence of Graco, or otherwise.

FOR GRACO CANADA CUSTOMERS

The parties acknowledge that they have required that the present document, as well as all documents, notices and legal proceedings entered into, given or instituted pursuant hereto or relating directly or indirectly hereto, be drawn up in English. Les parties reconnaissent avoir convenu que la rédaction du présente document sera en Anglais, ainsi que tous documents, avis et procédures judiciaires exécutés, donnés ou intentés à la suite de ou en rapport, directement ou indirectement, avec les procédures concernées.

Graco Information

TO PLACE AN ORDER, contact your Graco distributor, or call one of the following numbers to identify the distributor closest to you:

1-800-328-0211 Toll Free

612-623-6921

612-378-3505 Fax

All written and visual data contained in this document reflects the latest product information available at the time of publication. Graco reserves the right to make changes at any time without notice.

MM 308357

Graco Headquarters: Minneapolis
International Offices: Belgium, China, Japan, Korea

www.graco.com

PRINTED IN USA 308357 09/1994, Revised 00/2006