



INSTRUCTIONS

This manual contains important warnings and information.
READ AND KEEP FOR REFERENCE.

CARBON STEEL

Dura-Flo™ 1200 Pumps

With Severe-Duty Rod and Cylinder

Part No. 237-512 Pump, Series A,
21:1 Ratio, with Bulldog® Air Motor
145 bar (2100 psi) Maximum Fluid Working Pressure
7 bar (100 psi) Maximum Air Input Pressure

Part No. 237-513 Pump, Series A,
13:1 Ratio, with Senator® Air Motor
90 bar (1300 psi) Maximum Fluid Working Pressure
7 bar (100 psi) Maximum Air Input Pressure

Refer to page 2 for Table of Contents.

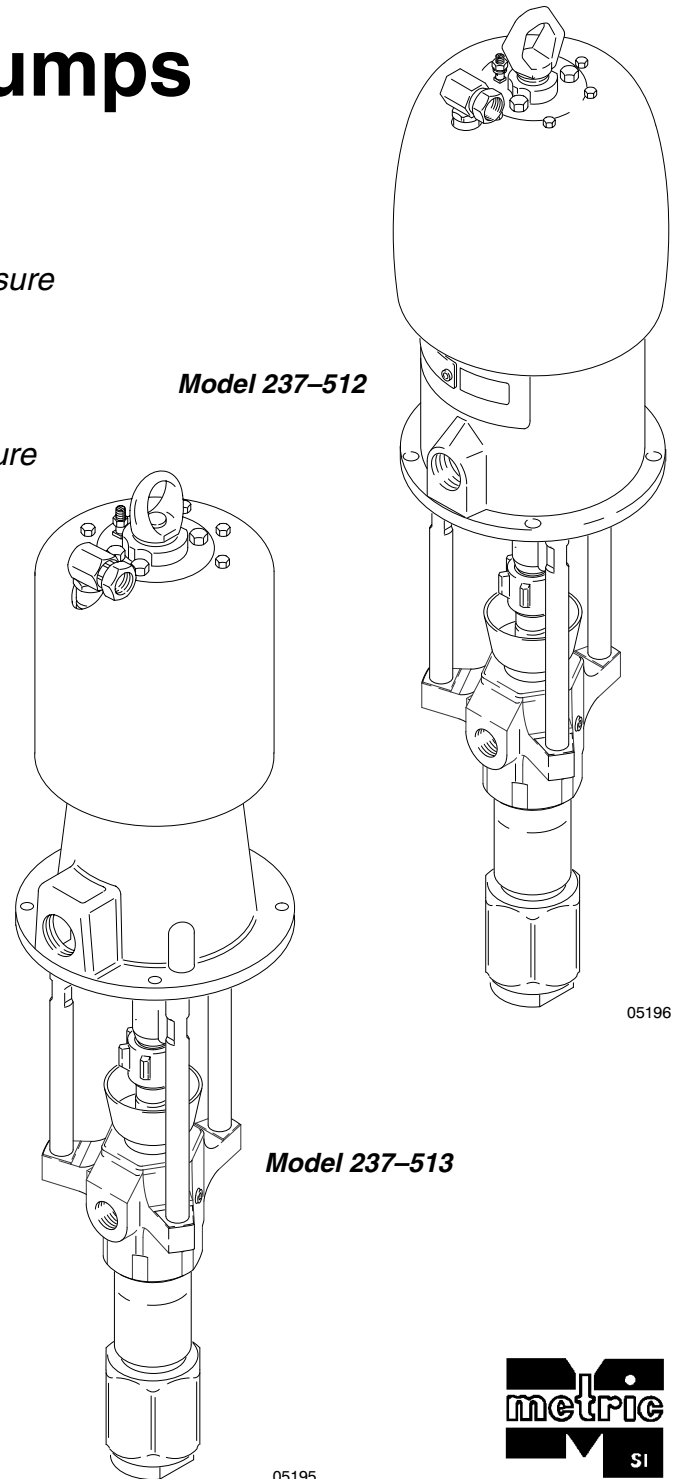

Model 237-512

Model 237-513

05196

05195



Table of Contents

Warnings	2
Installation	5
Operation/Maintenance	8
Troubleshooting Chart	11
Service	12
Required Tools	12
Disconnecting the Displacement Pump	12
Reconnecting the Displacement Pump	12
Displacement Pump Service	14
Parts Drawings and Parts Lists	18
Pump Assemblies	18
Displacement Pump	19
Technical Data	21
Dimensions	23
Mounting Hole Layout	23
Warranty	24
Graco Phone Numbers	24

Symbols

Warning Symbol



This symbol alerts you to the possibility of serious injury or death if you do not follow the instructions.

Caution Symbol



This symbol alerts you to the possibility of damage to or destruction of equipment if you do not follow the instructions.

! WARNING



INSTRUCTIONS

EQUIPMENT MISUSE HAZARD

Equipment misuse can cause the equipment to rupture or malfunction and result in serious injury.

- This equipment is for professional use only.
- Read all instruction manuals, tags, and labels before operating the equipment.
- Use the equipment only for its intended purpose. If you are not sure, call Graco Technical Assistance at 1-800-543-0339.
- Do not alter or modify this equipment.
- Check equipment daily. Repair or replace worn or damaged parts immediately.
- Do not exceed the maximum working pressure of the lowest rated system component. Refer to the **Technical Data** on pages 21-22 for the maximum working pressure of this equipment.
- Use fluids and solvents which are compatible with the equipment wetted parts. Refer to the **Technical Data** section of all equipment manuals. Read the fluid and solvent manufacturer's warnings.
- Do not use hoses to pull equipment.
- Route hoses away from traffic areas, sharp edges, moving parts, and hot surfaces. Do not expose Graco hoses to temperatures above 82°C (180°F) or below -40°C (-40°F).
- Wear hearing protection when operating this equipment.
- Do not lift pressurized equipment.
- Comply with all applicable local, state, and national fire, electrical, and safety regulations.

WARNING



INJECTION HAZARD

Spray from the gun, leaks or ruptured components can inject fluid into your body and cause extremely serious injury, including the need for amputation. Fluid splashed in the eyes or on the skin can also cause serious injury.



- Fluid injected into the skin might look like just a cut, but it is a serious injury. **Get immediate medical attention.**
- Do not point the gun at anyone or at any part of the body.
- Do not put your hand or fingers over the spray tip.
- Do not stop or deflect leaks with your hand, body, glove or rag.
- Do not “blow back” fluid; this is not an air spray system.
- Always have the tip guard and the trigger guard on the gun when spraying.
- Check the gun diffuser operation weekly. Refer to the gun manual.
- Be sure the gun trigger safety operates before spraying.
- Lock the gun trigger safety when you stop spraying.
- Follow the **Pressure Relief Procedure** on page 8 if the spray tip clogs and before cleaning, checking or servicing the equipment.
- Tighten all fluid connections before operating the equipment.
- Check the hoses, tubes, and couplings daily. Replace worn or damaged parts immediately. Do not repair high pressure couplings; you must replace the entire hose.
- Fluid hoses must have spring guards on both ends, to help protect them from rupture caused by kinks or bends near the couplings.



MOVING PARTS HAZARD

Moving parts, such as the air motor piston, can pinch or amputate your fingers.

- Keep clear of all moving parts when starting or operating the pump.
- Before servicing the equipment, follow the **Pressure Relief Procedure** on page 8 to prevent the equipment from starting unexpectedly.

WARNING



FIRE AND EXPLOSION HAZARD

Improper grounding, poor ventilation, open flames or sparks can cause a hazardous condition and result in a fire or explosion and serious injury.



- Ground the equipment and the object being sprayed. Refer to **Grounding** on page 5.
- If there is any static sparking or you feel an electric shock while using this equipment, **stop spraying immediately**. Do not use the equipment until you identify and correct the problem.
- Provide fresh air ventilation to avoid the buildup of flammable fumes from solvents or the fluid being sprayed.
- Keep the spray area free of debris, including solvent, rags, and gasoline.
- Electrically disconnect all equipment in the spray area.
- Extinguish all open flames or pilot lights in the spray area.
- Do not smoke in the spray area.
- Do not turn on or off any light switch in the spray area while operating or if fumes are present.
- Do not operate a gasoline engine in the spray area.



TOXIC FLUID HAZARD

Hazardous fluid or toxic fumes can cause serious injury or death if splashed in the eyes or on the skin, inhaled, or swallowed.

- Know the specific hazards of the fluid you are using.
- Store hazardous fluid in an approved container. Dispose of hazardous fluid according to all local, state and national guidelines.
- Always wear protective eyewear, gloves, clothing and respirator as recommended by the fluid and solvent manufacturer.

Manual Change Summary

The manual has been generally updated.

Installation

General Information

NOTE: Reference numbers and letters in parentheses in the text refer to the callouts in the figures and the parts drawing.

NOTE: Always use Genuine Graco Parts and Accessories, available from your Graco distributor. Refer to Product Data Sheet, Form No. 305-713 (Senator Pumps) and Form No. 305-714 (Bulldog Pumps). If you supply your own accessories, be sure they are adequately sized and pressure rated for your system.

Grounding

⚠ WARNING

FIRE AND EXPLOSION HAZARD
Before operating the pump, ground the system as explained below. Also read the section **FIRE OR EXPLOSION HAZARD** on page 4.



1. *Pump:* use a ground wire and clamp. See Fig. 1. Loosen the grounding lug locknut (W) and washer (X). Insert one end of a 1.5 mm² (12 ga) minimum ground wire (Y) into the slot in lug (Z) and tighten the locknut securely. Connect the other end of the wire to a true earth ground. Order Part No. 237-569 Ground Wire and Clamp.

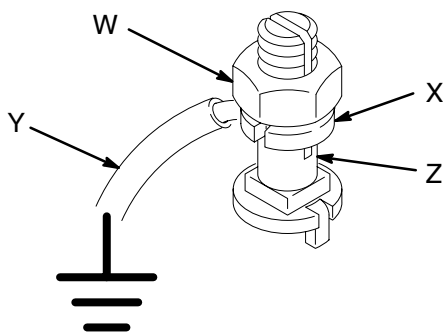

Fig. 1

0864

2. *Air and fluid hoses:* use only electrically conductive hoses.

3. *Air compressor:* follow manufacturer's recommendations.
4. *Spray gun:* ground through connection to a properly grounded fluid hose and pump.
5. *Fluid supply container:* follow your local code.
6. *Object being sprayed:* follow your local code.
7. *Solvent pails used when flushing:* follow your local code. Use only metal pails, which are conductive, placed on a grounded surface. Do not place the pail on a nonconductive surface, such as paper or cardboard, which interrupts the grounding continuity.
8. *To maintain grounding continuity when flushing or relieving pressure,* hold a metal part of the spray gun firmly to the side of a grounded *metal* pail, then trigger the gun.

System Accessories

Fig. 2 is only a guide for selecting and installing system components and accessories. Contact your Graco representative or Graco Technical Assistance (1-800-543-0339) for assistance in designing a system to suit your particular needs.

Air and Fluid Hoses

Be sure all air hoses (H) and fluid hoses (N and P) are properly sized and pressure-rated for your system. Use only electrically conductive hoses. Fluid hoses must have spring guards on both ends. Use a whip hose (P) and a swivel (R) between the main fluid hose (N) and the gun (S) to allow freer gun movement.

Mounting Accessories

Mount the pump (A) to suit the type of installation planned. Fig. 2 illustrates a wall mount system. Pump dimensions and the mounting hole layout are shown on page 23.

If you are using a floor stand, refer to its separate manual for installation and operation instructions.

Installation

System Accessories (continued)

WARNING

A bleed-type master air valve (E) and a fluid drain valve (M) are required in your system. These accessories help reduce the risk of serious injury, including fluid injection and splashing of fluid in the eyes or on the skin, and injury from moving parts if you are adjusting or repairing the pump.

The bleed-type master air valve relieves air trapped between this valve and the pump after the air is shut off. Trapped air can cause the pump to cycle unexpectedly. Locate the valve close to the pump. Order Part No. 107–141.

The fluid drain valve assists in relieving fluid pressure in the displacement pump, hose, and gun. Triggering the gun to relieve pressure may not be sufficient. Order Part No. 210–658.

Air Line Accessories

Install the following accessories in the locations shown in Fig. 2, using adapters as necessary:

- **An air line lubricator (D)** provides automatic air motor lubrication.
- **A bleed-type master air valve (E)** is required in your system to relieve air trapped between it and the air motor when the valve is closed (see the **WARNING** above). Be sure the bleed valve is easily accessible from the pump, and is located **downstream** from the air regulator.
- **An air regulator (F)** controls pump speed and outlet pressure by adjusting the air pressure to the pump. Locate the regulator close to the pump, but **upstream** from the bleed-type master air valve.

- **A pump runaway valve (C)** senses when the pump is running too fast and automatically shuts off the air to the motor. A pump which runs too fast can be seriously damaged.
- **An air manifold (G)** has a 3/4 npsm(f) swivel air inlet. It mounts to the pump support bracket, and provides ports for connecting lines to air-powered accessories.
- **An air line filter (J)** removes harmful dirt and moisture from the compressed air supply. Also, install a **drain valve (W)** at the bottom of each air line drop, to drain off moisture.
- **A second bleed-type air valve (K)** isolates the air line accessories for servicing. Locate upstream from all other air line accessories.

Fluid Line Accessories

Install the following accessories in the locations shown in Fig. 2, using adapters as necessary:

- **A fluid filter (L)** with a 60 mesh (250 micron) stainless steel element, to filter particles from the fluid as it leaves the pump.
- **A fluid drain valve (M)**, which is required in your system, helps relieve fluid pressure in the hose and gun (see the **WARNING** at left).
- **A gun (S)** dispenses the fluid. The gun shown in Fig. 2 is an airless spray gun for light to medium viscosity fluids.
- **A gun swivel (R)** allows freer gun movement.
- **A suction kit (T)** allows the pump to draw fluid from a supply container.

Installation

TYPICAL INSTALLATION

KEY

- | | | |
|---|--|---|
| A Pump | H Electrically Conductive Air Supply Hose | P Fluid Whip Hose |
| B Wall Bracket | J Air Line Filter | R Gun Swivel |
| C Pump Runaway Valve | K Bleed-Type Master Air Valve (for accessories) | S Airless Spray Gun |
| D Air Line Lubricator | L Fluid Filter | T Suction Kit |
| E Bleed-Type Master Air Valve (required, for pump) | M Fluid Drain Valve (required) | Y Ground Wire and Clamp (required; see page 5 for installation instructions) |
| F Pump Air Regulator | N Electrically Conductive Fluid Supply Hose | W Air Line Drain Valve |
| G Air Manifold | | |

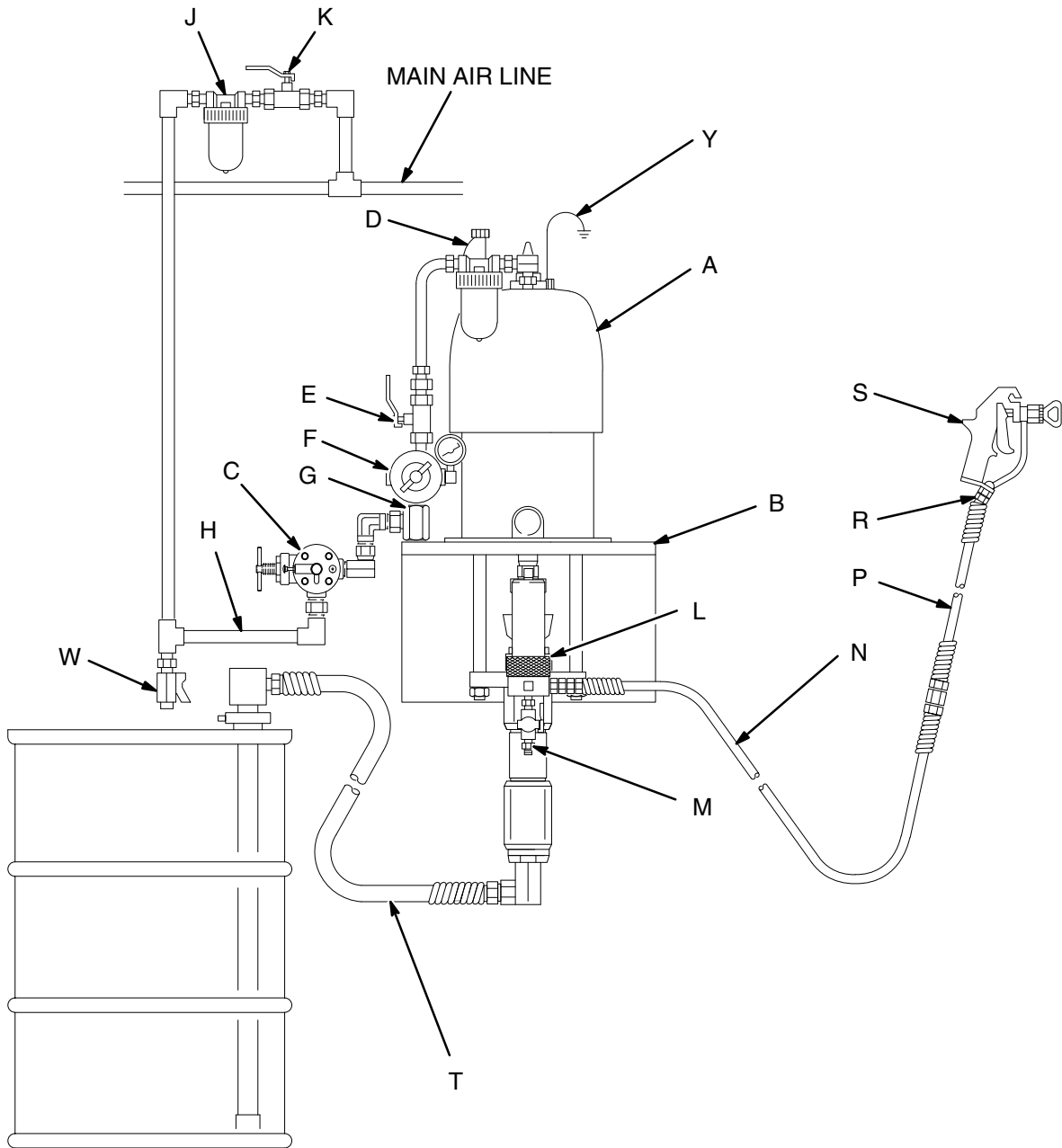

Fig. 2

04177

Operation/Maintenance

Pressure Relief Procedure

WARNING



INJECTION HAZARD

The system pressure must be manually relieved to prevent the system from starting or spraying accidentally. Fluid under high pressure can be injected through the skin and cause serious injury. To reduce the risk of an injury from injection, splashing fluid, or moving parts, follow the **Pressure Relief Procedure** whenever you:

- are instructed to relieve the pressure,
- stop spraying,
- check or service any of the system equipment,
- or install or clean the spray tips.

1. Lock the gun trigger safety.
2. Shut off the air supply to the pump.
3. Close the bleed-type master air valve (required in your system).
4. Unlock the gun trigger safety.
5. Hold a metal part of the gun firmly to the side of a grounded metal pail, and trigger the gun to relieve pressure.
6. Lock the gun trigger safety.
7. Open the drain valve (required in your system), having a container ready to catch the drainage.
8. Leave the drain valve open until you are ready to spray again.

If you suspect that the spray tip or hose is completely clogged, or that pressure has not been fully relieved after following the steps above, very slowly loosen the tip guard retaining nut or hose end coupling and relieve pressure gradually, then loosen completely. Now clear the tip or hose.

Packing Nut/Wet-Cup

Before starting, fill the packing nut (2) 1/3 full with Graco Throat Seal Liquid (TSL) or compatible solvent. See Fig. 3.

WARNING

To reduce the risk of serious injury whenever you are instructed to relieve pressure, always follow the **Pressure Relief Procedure** at left.

The packing nut is torqued at the factory and is ready for operation. If it becomes loose and there is leaking from the throat packings, **relieve the pressure**, then torque the nut to 136–149 N.m (100–110 ft-lb) using the supplied wrench (110). Do this whenever necessary. Do not overtighten the packing nut.

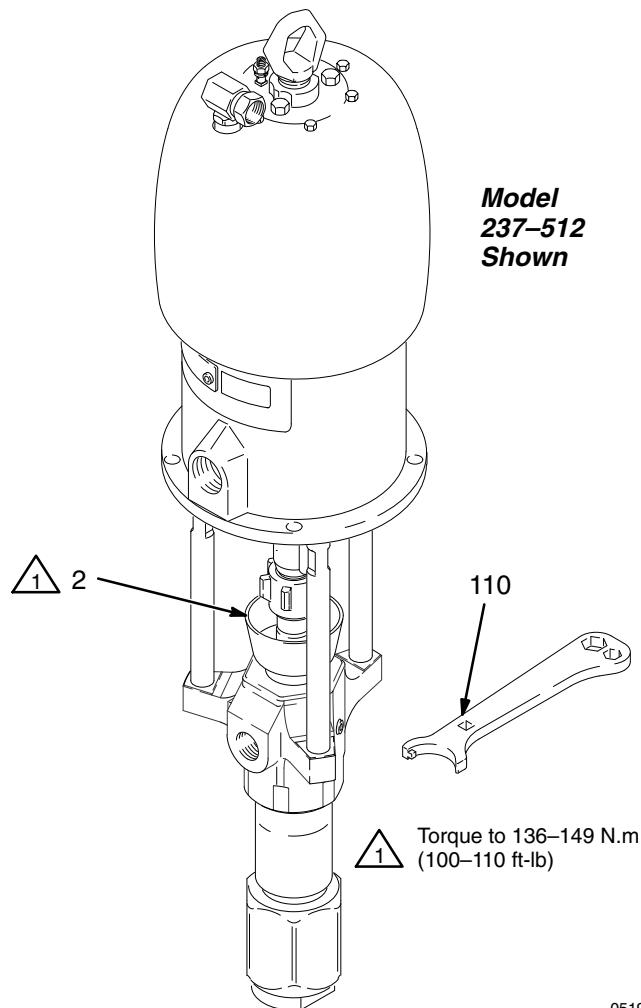

Fig. 3

05196

Operation/Maintenance

Flush the Pump Before First Use

The pump is tested with lightweight oil, which is left in to protect the pump parts. If the fluid you are using may be contaminated by the oil, flush it out with a compatible solvent. See **Flushing** on page 10.

Starting and Adjusting the Pump

1. See Fig. 2. Connect the suction kit (T) to the pump's fluid inlet. Place the tube into the fluid supply.
2. Close the air regulator (F).
3. Open the pump's bleed-type master air valve (E).
4. Hold a metal part of the gun (S) firmly to the side of a grounded metal pail and hold the trigger open.
5. Slowly open the regulator until the pump starts.
6. Cycle the pump slowly until all air is pushed out and the pump and hoses are fully primed.
7. Release the gun trigger and engage the safety latch. The pump should stall against pressure.
8. If the pump fails to prime properly, open the drain valve (M). Use the drain valve as a priming valve until the fluid flows from the valve. Close the valve.

NOTE: When changing fluid containers with the hose and gun already primed, open the drain valve (M) to help prime the pump and vent air before it enters the hose. Close the drain valve when all air is eliminated.

CAUTION

Do not allow the pump to run dry. It will quickly accelerate to a high speed, causing damage. If your pump is running too fast, stop it immediately and check the fluid supply. If the container is empty and air has been pumped into the lines, refill the container and prime the pump and the lines, or flush and leave it filled with a compatible solvent. Eliminate all air from the fluid system.

9. With the pump and lines primed, and with adequate air pressure and volume supplied, the pump will start and stop as you open and close the gun. In a circulating system, the pump will speed up or slow down on demand, until the air supply is shut off.

WARNING

COMPONENT RUPTURE HAZARD



To reduce the risk of overpressurizing your system, which could cause component rupture and serious injury, *never exceed the specified Maximum Incoming Air Pressure to the pump* (see the **Technical Data**, on pages 21 and 22).

10. Use the air regulator (F) to control pump speed and fluid pressure. Always use the lowest air pressure necessary to get the desired results. Higher pressures cause premature tip and pump wear.

Operation/Maintenance

Shutdown and Care of the Pump

WARNING

To reduce the risk of serious injury whenever you are instructed to relieve pressure, always follow the **Pressure Relief Procedure** on page 8.

For overnight shutdown, stop the pump at the bottom of its stroke to prevent fluid from drying on the exposed displacement rod and damaging the throat packings. **Relieve the pressure.**

Always flush the pump before the fluid dries on the displacement rod. See **Flushing** below.

Flushing

WARNING



FIRE AND EXPLOSION HAZARD

Before flushing, read the section **FIRE OR EXPLOSION HAZARD** on page 4.



Be sure the entire system and flushing pails are properly grounded. Refer to **Grounding** on page 5.

Flush with a fluid that is compatible with the fluid you are pumping and with the wetted parts in your system. Check with your fluid manufacturer or supplier for recommended flushing fluids and flushing frequency. Always flush the pump before fluid dries on the displacement rod.

CAUTION

Never leave water or water-base fluid in the pump overnight. If you are pumping water-base fluid, flush with water first, then with a rust inhibitor such as mineral spirits. Relieve the pressure, but leave the rust inhibitor in the pump to protect the parts from corrosion.

WARNING

To reduce the risk of serious injury whenever you are instructed to relieve pressure, always follow the **Pressure Relief Procedure** on page 8.

1. **Relieve the pressure.**
2. Remove the spray tip from the gun.
3. Hold a metal part of the gun firmly to the side of a grounded *metal* pail.
4. Start the pump. Always use the lowest possible fluid pressure when flushing.
5. Trigger the gun.
6. Flush the system until clear solvent flows from the gun.
7. **Relieve the pressure.**

Troubleshooting Chart

WARNING

To reduce the risk of serious injury whenever you are instructed to relieve pressure, always follow the **Pressure Relief Procedure** on page 8.

1. **Relieve the pressure.**
2. Check all possible causes and problems before disassembling the pump.

PROBLEM	CAUSE	SOLUTION
The pump fails to operate.	Restricted air line or an inadequate air supply; closed or clogged valves.	Clear the line; increase the air supply. Check that the valves are open.
	Obstructed fluid hose or gun; the fluid hose ID is too small.	Open, clear*; use a hose with a larger ID.
	Fluid has dried on the displacement rod.	Clean the rod; always stop the pump at the bottom of its stroke; keep the wet-cup 1/3 filled with a compatible solvent.
	Dirty, worn, or damaged motor parts.	Clean or repair; see the separate motor manual.
The pump operates, but the output is low on both strokes.	Restricted air line or an inadequate air supply; closed or clogged valves.	Clear the line; increase the air supply. Check that the valves are open.
	Obstructed fluid hose or gun; the fluid hose ID is too small.	Open, clear*; use a hose with a larger ID.
	Worn packings in the displacement pump.	Replace the packings.
The pump operates, but the output is low on the downstroke.	Held open or worn intake valve.	Clear the valve; service.
The pump operates, but the output is low on the upstroke.	Held open or worn piston valve or packings.	Clear the valve; replace the packings.
Erratic or accelerated pump speed.	Exhausted fluid supply.	Refill the supply and prime the pump.
	Held open or worn piston valve or packings.	Clear the valve; replace the packings.
	Held open or worn intake valve.	Clear the valve; service.

* To determine if the fluid hose or gun is obstructed, follow the **Pressure Relief Procedure** on page 8. Disconnect the fluid hose and place a container at the pump fluid outlet to catch any fluid. Turn on the air just enough to start the pump. If the pump starts when the air is turned on, the obstruction is in the fluid hose or gun.

NOTE: If you experience air motor icing, call Graco Technical Assistance (1-800-543-0339).

Service

Required Tools

- Set of adjustable wrenches
- Large pipe wrench
- Torque wrench
- Rubber mallet
- O-ring pick
- Large vise
- Thread lubricant
- Thread sealant

Disconnecting the Displacement Pump

1. Flush the pump, if possible. Stop the pump at the bottom of its stroke.

WARNING

To reduce the risk of serious injury whenever you are instructed to relieve pressure, always follow the **Pressure Relief Procedure** on page 8.

2. **Relieve the pressure.**
3. Disconnect the air hose and fluid hose.
4. Disconnect the displacement pump (109) from the motor (101) as follows. Note the relative position of the pump's fluid outlet (U) to the air inlet (V) of the motor. If the motor does not require servicing, leave it attached to its mounting.

CAUTION

Be sure to use *at least* two people when lifting, moving, or disconnecting the pump. This pump is too heavy for one person. If you are disconnecting the displacement pump from a motor which is still mounted (for example, on a wall bracket), *be sure* to support the displacement pump while it is being disconnected, to prevent it from falling and causing injury or property damage. Do this by securely bracing the pump, or by having at least two people hold it while another disconnects it.

If the pump is mounted on a cart, slowly tip the cart backward until the handle rests on the ground, then disconnect the displacement pump.

5. Using an adjustable wrench (or hammer and punch), unscrew the coupling nut (106) from the motor shaft (W). Do not lose or drop the coupling collars (107). See Fig. 4.
6. Hold the tie rod flats with a wrench to keep the rods from turning. Unscrew the nuts (108) from the tie rods (105). Carefully remove the displacement pump (109) from the motor (101).
7. Refer to page 14 for displacement pump service. To service the air motor, refer to the separate motor manual, supplied.

Reconnecting the Displacement Pump

1. Make sure the coupling nut (106) and the coupling collars (107) are in place on the displacement rod (1). See Fig. 4.
2. Use at least two people to hold the displacement pump while another reconnects it to the motor (see the **CAUTION** at left). Orient the pump's fluid outlet (U) to the air inlet (V) as was noted in step 4 under **Disconnecting the Displacement Pump**. Position the displacement pump (109) on the tie rods (105).
3. Screw the nuts (108) onto the tie rods (105) and torque to 81–89 N.m (60–66 ft-lb).
4. Screw the coupling nut onto the motor shaft (W) loosely. Hold the motor shaft flats with a wrench to keep it from turning. Use an adjustable wrench to tighten the coupling nut. Torque to 196–210 N.m (145–155 ft-lb).
5. Reconnect all hoses. Reconnect the ground wire if it was disconnected. Fill the packing nut (2) 1/3 full of Graco Throat Seal Liquid or compatible solvent.
6. Turn on the air supply. Run the pump slowly to ensure proper operation.

WARNING

To reduce the risk of serious injury whenever you are instructed to relieve pressure, always follow the **Pressure Relief Procedure** on page 8.

7. Before returning the pump to production, **relieve the pressure** and retorque the packing nut (2) to 136–149 N.m (100–110 ft-lb).

Service

Model 237-512 Shown

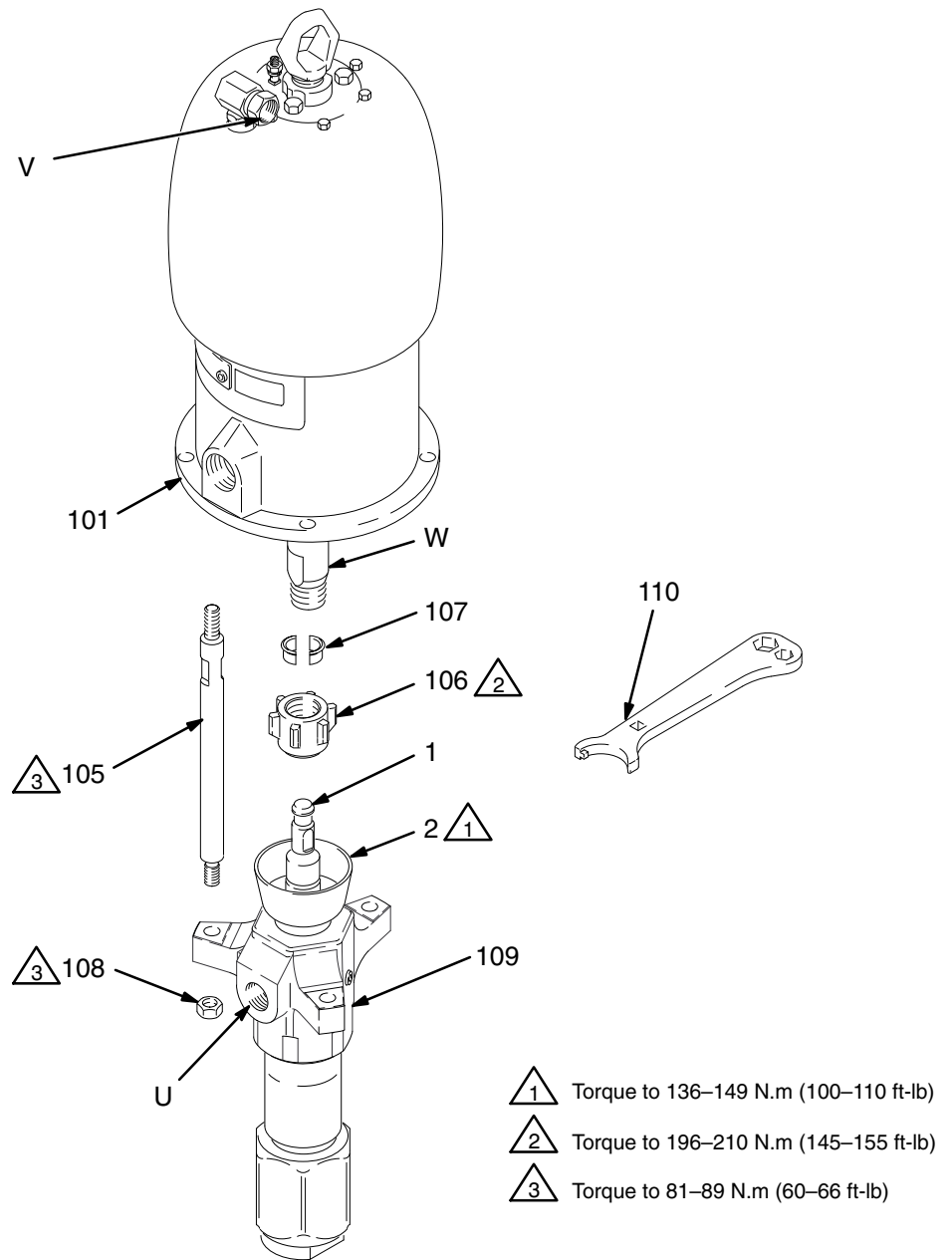

Fig. 4

05190

Service

DISPLACEMENT PUMP SERVICE

Disassembly

When disassembling the pump, lay out all the removed parts in sequence, to ease reassembly.

NOTE: Packing Repair Kits are available. For the best results, use all the new parts in the kit. Kit parts are marked with an asterisk, for example (3*). You can also convert the pump to different packing materials. Refer to page 20.

1. Place the pump lengthwise in a large vise, with the jaws on the outlet housing (7) as shown in Fig. 5. Using the supplied wrench (110), loosen, but do not remove, the packing nut (2).
2. Apply a pipe wrench to the flats of the intake valve (19). Unscrew the intake valve (19) from the intake housing (18). Be careful to catch the intake ball (17) as you remove the intake valve, so that it does not fall and suffer damage. Remove the seal (8) from the intake valve. Inspect the ball and the seat (D) of the intake valve for wear or damage.
3. Apply a pipe wrench to the hex of the valve housing (18). The pump assembly may separate at joint A or joint B.

CAUTION

To reduce the possibility of costly damage to the rod (1) and cylinder (9), *always* use a rubber mallet to drive the rod out of the cylinder. *Never* use a hammer.

• *If the assembly separates at joint A:*

- a. Unscrew the valve housing (18) from the cylinder. Using a rubber mallet, drive the displacement rod (1) and piston assembly out of the outlet housing (7) and cylinder (9) until the piston comes free. Pull the rod and piston from the cylinder, being careful not to scratch the parts.
- b. Unscrew the cylinder (9) from the outlet housing (7), using a pipe wrench. Remove the two seals (8) from the cylinder. Shine a light into the cylinder (9) to inspect the inner surface for scoring or wear. Now go to step 4.

• *If the assembly separates at joint B:*

- a. Unscrew the cylinder (9) and valve housing (18) from the outlet housing (7). Gently pull the cylinder and valve housing straight out of the outlet housing; the displacement rod (1) and piston assembly will come out with these parts.
 - b. Place the valve housing (18) in the vise and unscrew the cylinder (9) from the housing, using a pipe wrench. The displacement rod (1) and piston assembly will remain in the cylinder.
 - c. Using a rubber mallet, drive the displacement rod (1) and piston assembly out of the cylinder (9) until the piston comes free. Pull the rod and piston from the cylinder, being careful not to scratch the parts.
 - d. Remove the two seals (8) from the cylinder. Shine a light into the cylinder (9) to inspect the inner surface for scoring or wear. Now go to step 4.
4. Place the flats of the piston seat housing (16) in a vise, as shown in Fig. 6.
 5. Using an adjustable wrench, unscrew the piston ball housing (10) from the piston seat housing. Be careful to catch the piston ball (11) as you separate the piston seat housing and ball housing, so that it does not fall and suffer damage.
 6. Examine the displacement rod (1) for scratches or other damage. **Only if the rod needs replacement**, unscrew it from the piston ball housing (10), using an adjustable wrench on the flats of the rod.
 7. Remove the glands and v-packings (P) from the piston seat housing (16). Inspect the ball (11), and the seat (E) and guides (F) on the housing for wear or damage. See Fig. 7.
 8. Unscrew the packing nut (2) from the outlet housing (7). Remove the glands and v-packings (T). See Fig. 7.
 9. Clean all parts with a compatible solvent and inspect them for wear or damage.

Service

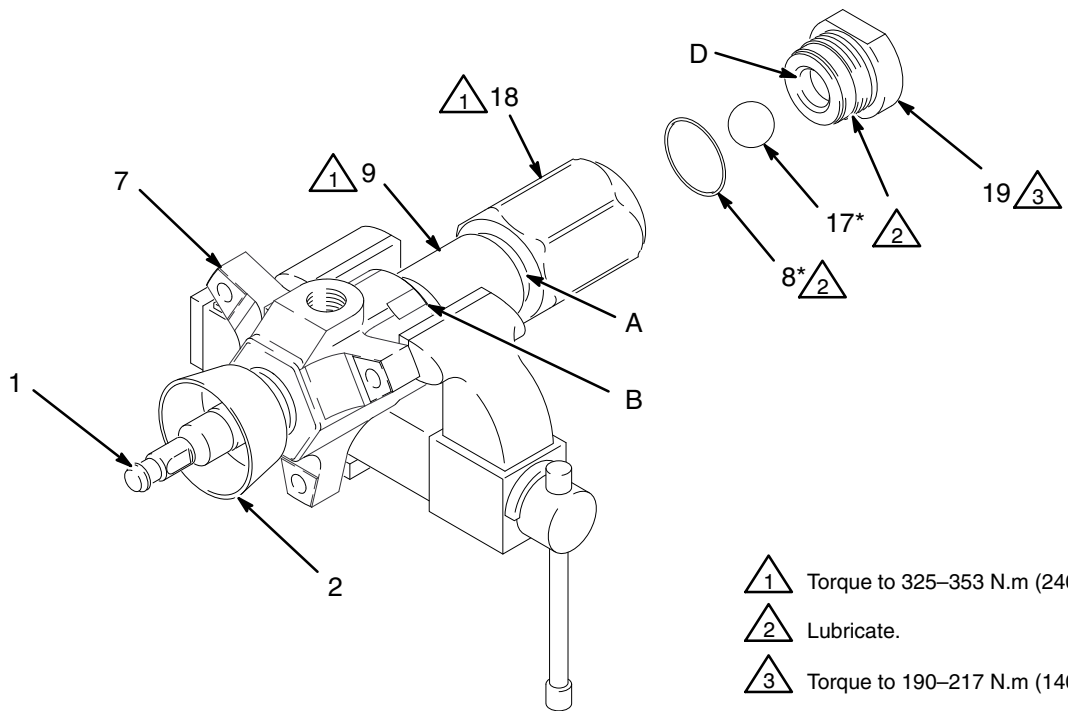

Fig. 5

05183

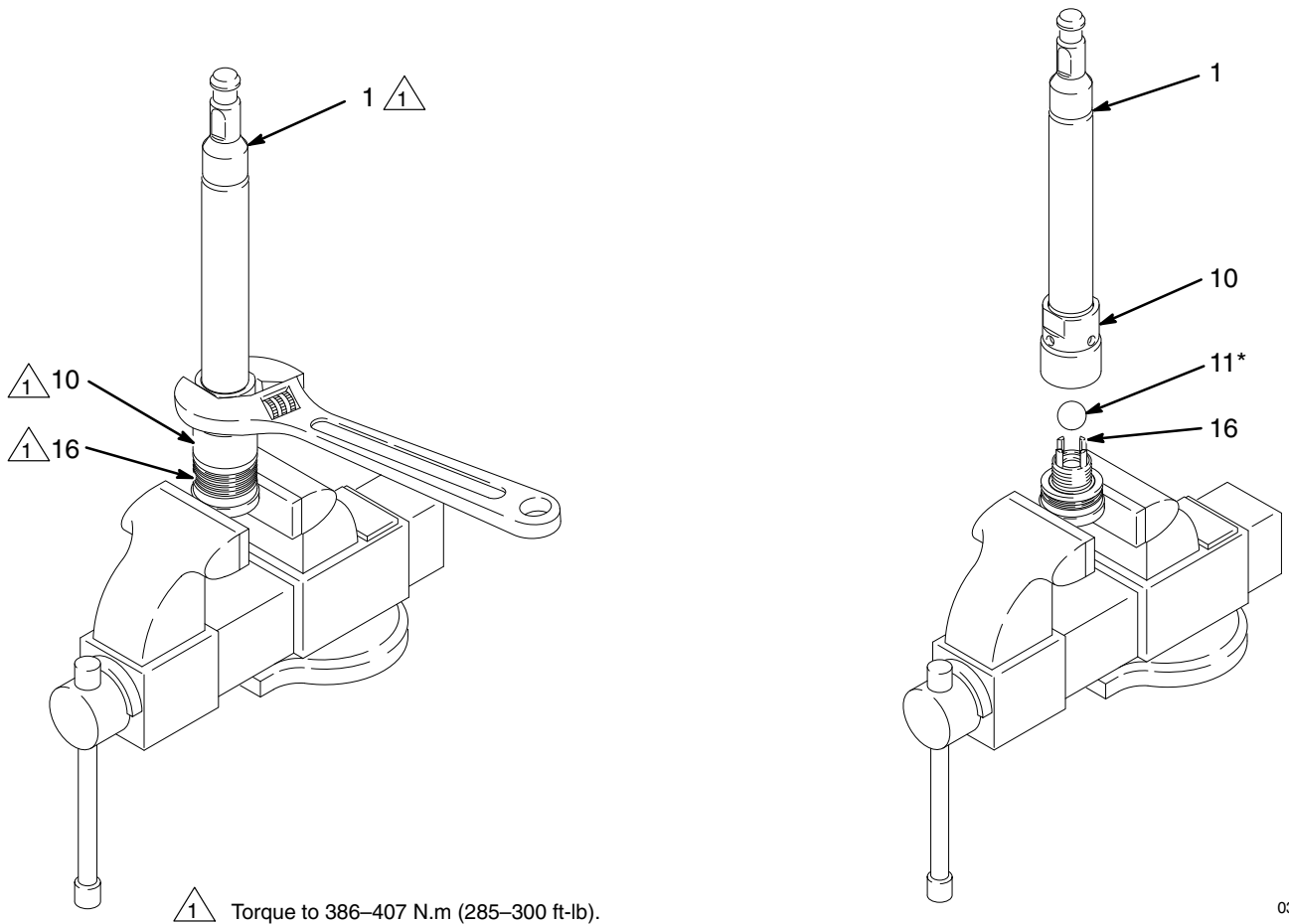

Fig. 6

03793A

Service

Reassembly

1. If it was necessary to remove the piston ball housing (10) from the displacement rod (1), clean the threads of the rod and the ball housing. Screw the ball housing onto the rod, hand tight. Place the flats of the piston ball housing in a vise and torque the rod to 386–407 N.m (285–300 ft-lb). See Fig. 7.
2. For standard displacement pump 237–510, place the piston packings on the piston seat housing (16) in the following order, **with the lips of the v-packings facing up**: the female gland (15*), one PTFE v-packing (14*), four leather v-packings (12*), and the male gland (13*). See the Piston Packing Stack Detail in Fig. 7.

NOTE: If your pump uses an optional packing configuration, or you want to convert the pump to a different packing material, see page 20.









3. Place the flats of the piston seat housing (16) in a vise. Place the ball (11*) on the piston seat (E). Screw the piston ball housing (10) onto the piston seat housing hand tight, then torque to 386–407 N.m (285–300 ft-lb). See Fig. 6.
4. For standard displacement pump 237–510, lubricate the throat packings and place them in the outlet housing (7) in the following order, **with the lips of the v-packings facing down**: the male gland (6*), four leather v-packings (3*), one PTFE v-packing (5*), and the female gland (4*). See the Throat Packing Stack Detail in Fig. 7.

NOTE: If your pump uses an optional packing configuration, or you want to convert the pump to a different packing material, see page 20.

5. Install the packing nut (2) loosely into the outlet housing (7).

6. Lubricate the piston packings. Slide the displacement rod (1) and piston assembly down into the cylinder (9). The cylinder is symmetrical, so either end may face up. Use a rubber mallet to drive the rod into the cylinder, until the piston seat housing (16) is near the bottom of the cylinder.
7. Install the seal (8*) on the top of the cylinder (9). Lubricate the seal and the top threads of the cylinder.
8. Place the outlet housing (7) in a vise, as shown in Fig. 5. Slide the displacement rod (1) up into the outlet housing, then screw the cylinder (9) into the outlet housing handtight. The threads will engage easily until the seal (8*) contacts the sealing surface of the outlet housing. The top of the rod will protrude from the packing nut (2).
9. Install the seal (8*) on the bottom of the cylinder (9). Lubricate the seal and the threads of the cylinder. **With the beveled ball stop surfaces (S) facing down (see Fig. 7)**, screw the intake housing (18) onto the cylinder handtight. The threads will engage easily until the seal contacts the sealing surface of the intake housing.
10. Install the seal (8*) on the intake valve (19). Lubricate the seal and the threads of the intake valve. Place the intake ball (17*) in the intake housing (18), then screw the intake valve into the intake housing handtight. The threads will engage easily until the seal contacts the sealing surface of the intake housing.
11. Using a pipe wrench, torque the intake housing (18) to 325–353 N.m (240–260 ft-lb). This will torque both cylinder joints (A and B). See Fig. 5.
12. Using a pipe wrench, torque the intake valve (19) to 190–217 N.m (140–150 ft-lb). See Fig. 5.
13. Torque the packing nut (2) to 136–149 N.m (100–110 ft-lb).
14. Reconnect the displacement pump to the air motor as explained on page 12.

Service

-  Torque to 136–149 N.m (100–110 ft-lb).
-  Torque to 325–353 N.m (240–260 ft-lb).
-  Torque to 386–407 N.m (285–300 ft-lb).
-  Lubricate.
-  Lips face up.
-  Lips face down.
-  See Throat Packing Detail at left.
-  See Piston Packing Detail at left.
-  Torque to 190–217 N.m (140–160 ft-lb).

Throat Packing Stack Detail (Displacement Pump 237–510 Shown; see page 20 for options.)

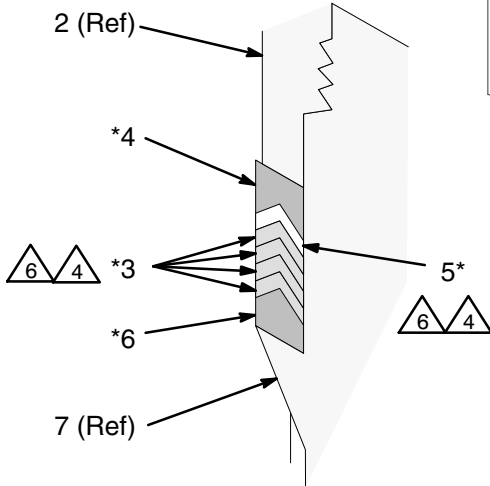

Piston Packing Stack Detail (Displacement Pump 237–510 Shown; see page 20 for options.)

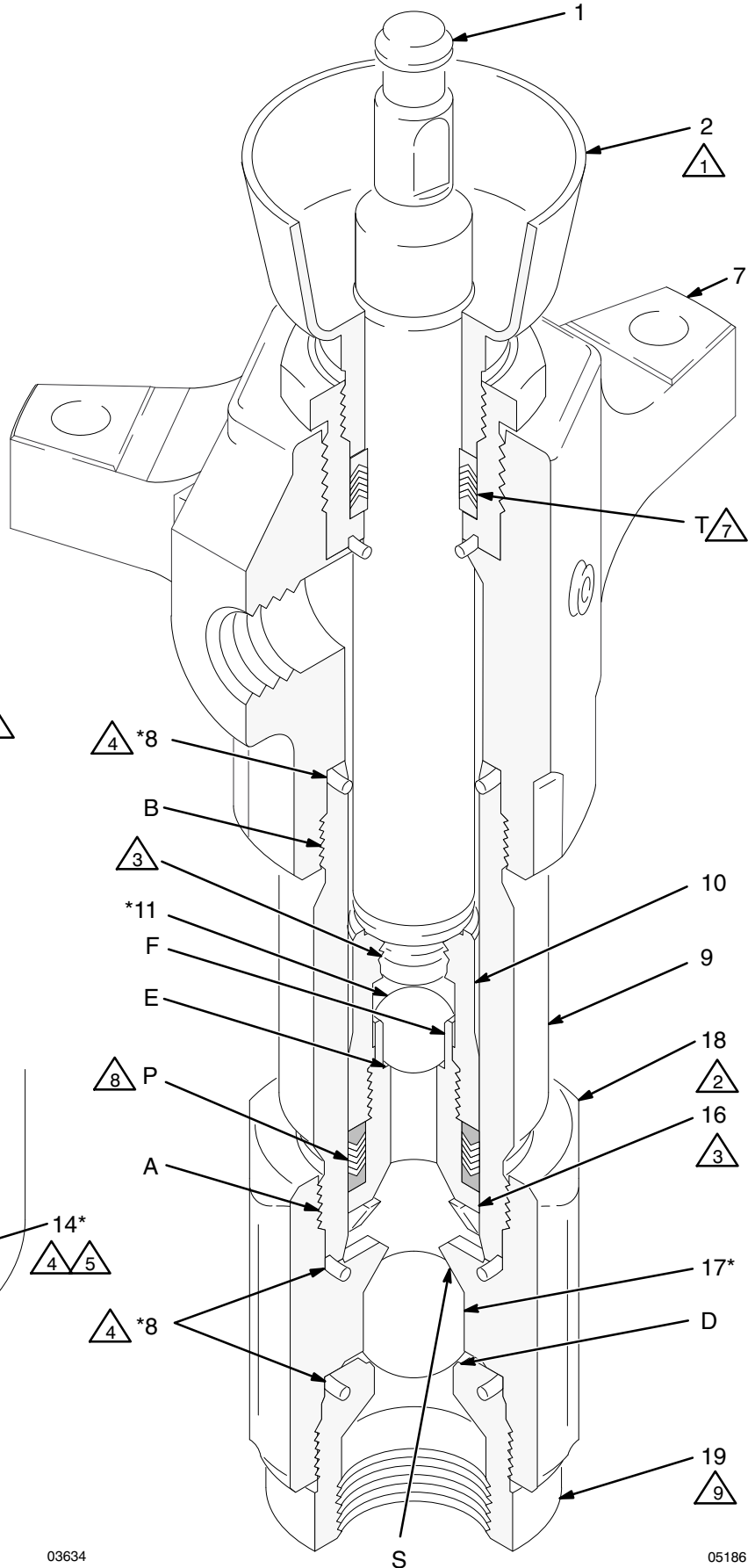
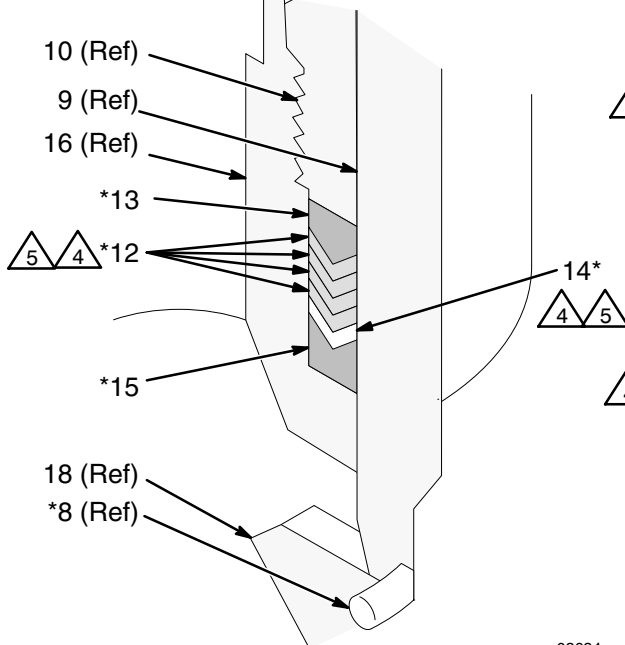

Fig. 7

03634

05186

Parts

Part No. 237-512 Pump, Series A 21:1 Ratio, with Bulldog Air Motor

Part No. 237-513 Pump, Series A 13:1 Ratio, with Senator Air Motor

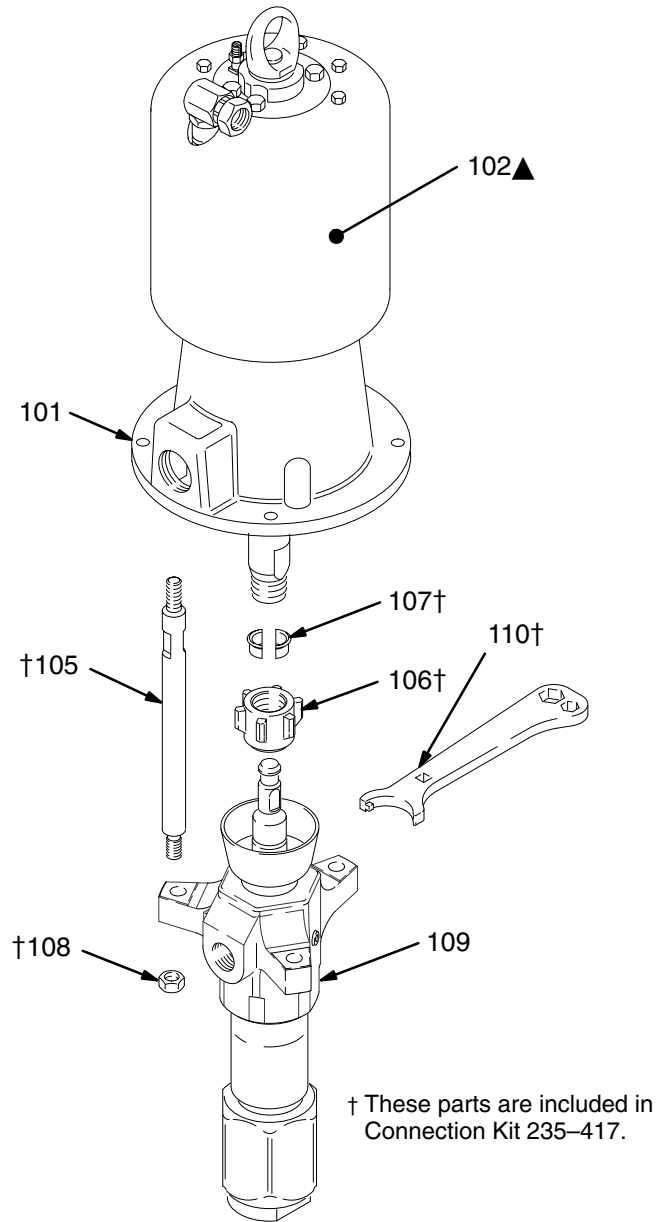
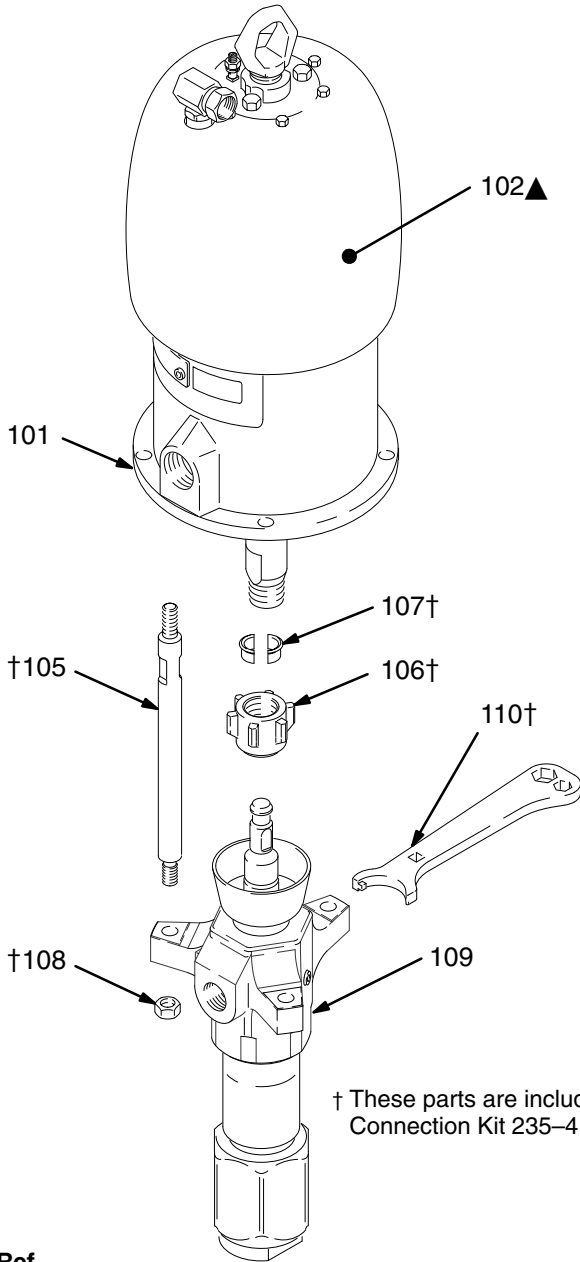

Ref. No.	Part No.	Description	Qty.
101	208-356	AIR MOTOR, Bulldog See 307-049 for parts	1
102▲	176-529	LABEL, warning	1
105†	190-000	ROD, tie; 224 mm (8.82") shoulder to shoulder	3
106†	186-925	NUT, coupling	1
107†	184-129	COLLAR, coupling	2
108†	106-166	NUT, hex; M16 x 2.0	3
109	237-510	PUMP, displacement See page 19 for parts	1
110†	112-887	WRENCH, spanner	1

05190

Ref. No.	Part No.	Description	Qty.
101	217-540	AIR MOTOR, Senator See 307-592 for parts	1
102▲	176-529	LABEL, warning	1
105†	190-000	ROD, tie; 224 mm (8.82") shoulder to shoulder	3
106†	186-925	NUT, coupling	1
107†	184-129	COLLAR, coupling	2
108†	106-166	NUT, hex; M16 x 2.0	3
109	237-510	PUMP, displacement See page 19 for parts	1
110†	112-887	WRENCH, spanner	1

05191

▲ Replacement Danger and Warning labels, tags and cards are available at no cost.

▲ Replacement Danger and Warning labels, tags and cards are available at no cost.

Parts

NOTE: The parts listed on this page are common to all displacement pumps covered in this manual. Refer to page 20 for the different packing configurations available.

* These parts are included in Repair Kit 237-169, which may be purchased separately for standard Displacement Pump 237-510. See page 20. They are also included in Optional Kits 237-170, 237-171, and 237-712.

▲ Replacement Danger and Warning labels, tags and cards are available at no cost.

Ref No.	Part No.	Description	Qty
1	184-487	ROD, displacement; stainless steel	1
2	222-995	PACKING NUT; carbon steel	1
7	237-185	HOUSING, outlet; nickel-plated ductile iron	1
8*	109-499	SEAL; PTFE	3
9	184-540	CYLINDER; stainless steel	1
10	184-513	HOUSING, ball, piston; carbon steel	1
11*	100-279	BALL, piston; chrome steel; 0.875" (22.2 mm) dia.	1
16	222-951	HOUSING, seat, piston valve; stainless steel w/tungsten carbide seat	1
17*	108-001	BALL, intake; stainless steel; 1.5" (38.1 mm) dia.	1
18	184-538	HOUSING, intake valve; ductile iron	1
19	222-952	VALVE, intake; ductile iron w/tungsten carbide seat	1
22	101-754	PLUG, pipe, socket hd; 3/8 npt	1
24▲	172-477	TAG, warning (not shown)	1
25▲	172-479	TAG, warning (not shown)	1

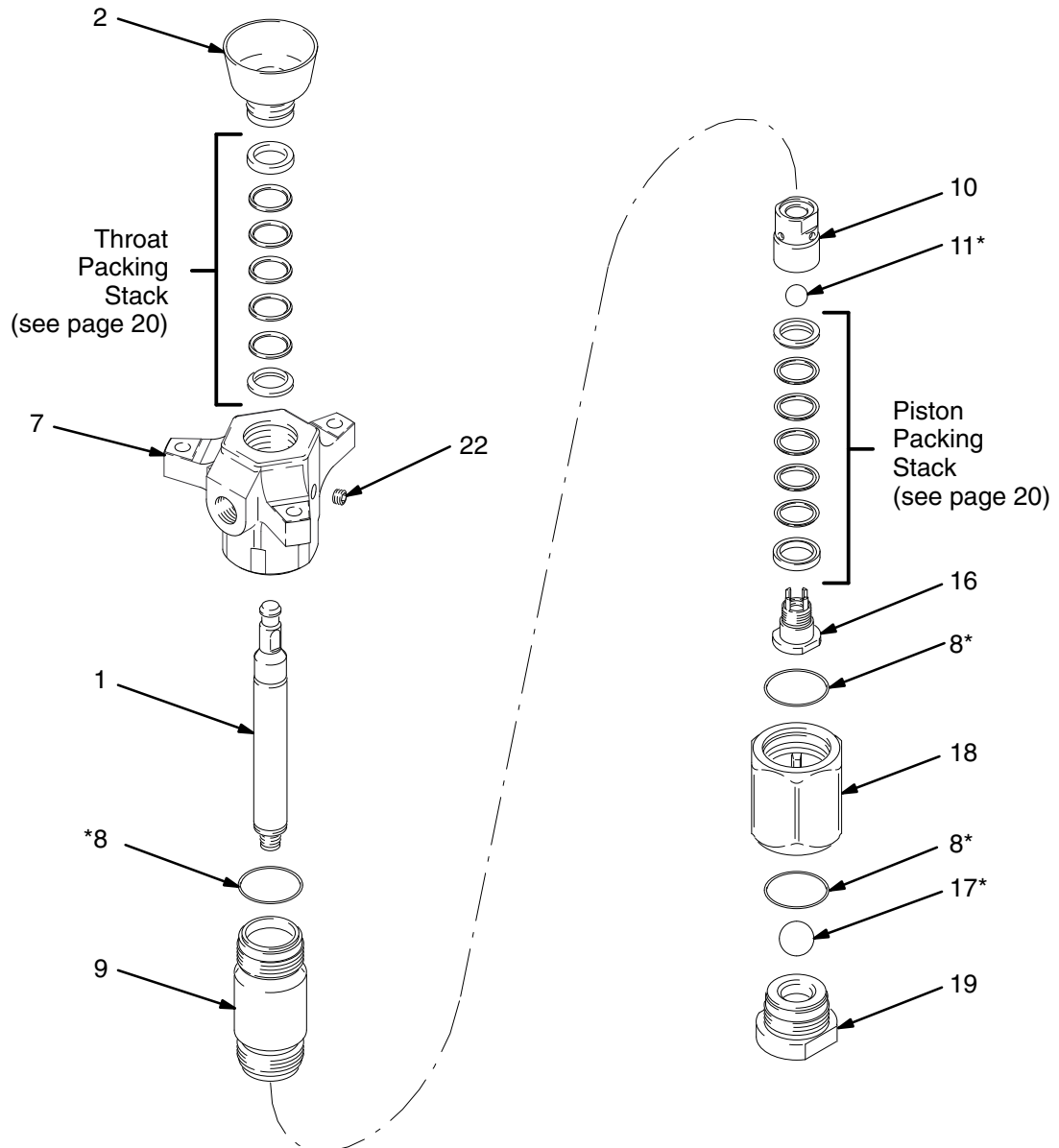

Packing Kits

Leather Packing Kit 237–169, for Standard Displacement Pump 237–510, Series A

Ref No.	Part No.	Description	Qty
3*	184–309	V-PACKING, throat; leather	4
4*	184–204	GLAND, throat, female; carbon steel	1
5*	109–309	V-PACKING, throat; PTFE	1
6*	184–254	GLAND, throat, male; carbon steel	1
12*	184–310	V-PACKING, piston; leather	4
13*	184–255	GLAND, piston, male; carbon steel	1
14*	109–310	V-PACKING, piston; PTFE	1
15*	184–205	GLAND, piston, female; carbon steel	1

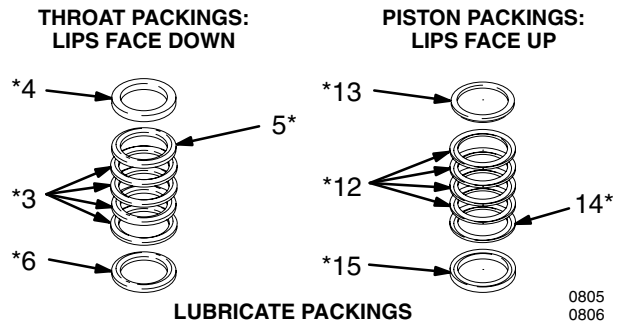

* Kit also includes items 8, 11, and 17 (see page 19).

UHMWPE and Leather Packing Kit 237–171, for Optional Displacement Pump 237–511, Series A

Ref No.	Part No.	Description	Qty
3*	184–309	V-PACKING, throat; leather	2
4*	184–204	GLAND, throat, female; carbon steel	1
5*	109–259	V-PACKING, throat; UHMWPE	3
6*	184–254	GLAND, throat, male; carbon steel	1
12*	184–310	V-PACKING, piston; leather	2
13*	184–255	GLAND, piston, male; carbon steel	1
14*	109–260	V-PACKING, piston; UHMWPE	3
15*	184–205	GLAND, piston, female; carbon steel	1

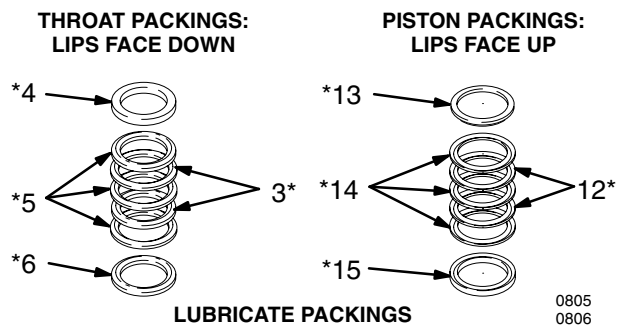

* Kit also includes items 8, 11, and 17 (see page 19).

PTFE Packing Kit 237–170, for Optional Displacement Pump 222–953, Series A

Ref No.	Part No.	Description	Qty
4*	184–204	GLAND, throat, female; carbon steel	1
5*	109–309	V-PACKING, throat; PTFE	5
6*	184–254	GLAND, throat, male; carbon steel	1
13*	184–255	GLAND, piston, male; carbon steel	1
14*	109–310	V-PACKING, piston; PTFE	5
15*	184–205	GLAND, piston, female; carbon steel	1

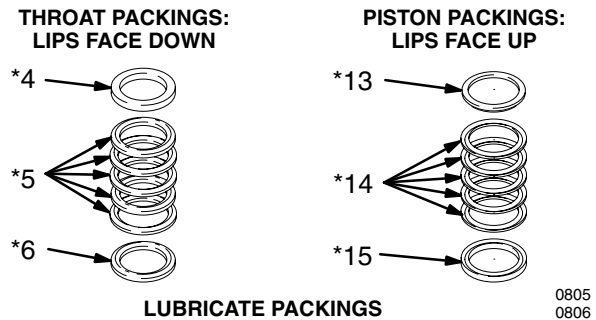

* Kit also includes items 8, 11, and 17 (see page 19).

UHMWPE and PTFE Packing Kit 237–712 (Optional)

Ref No.	Part No.	Description	Qty
3*	109–309	V-PACKING, throat; PTFE	2
4*	184–204	GLAND, throat, female; carbon steel	1
5*	109–259	V-PACKING, throat; UHMWPE	3
6*	184–254	GLAND, throat, male; carbon steel	1
12*	109–310	V-PACKING, piston; PTFE	2
13*	184–255	GLAND, piston, male; carbon steel	1
14*	109–260	V-PACKING, piston; UHMWPE	3
15*	184–205	GLAND, piston, female; carbon steel	1

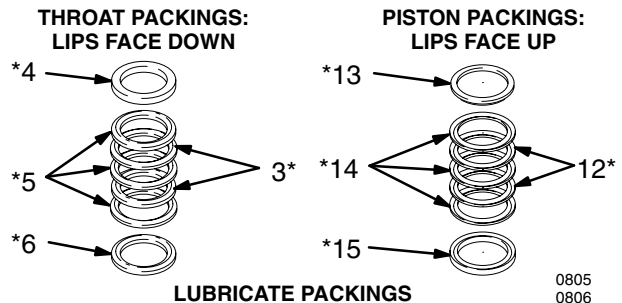

* Kit also includes items 8, 11, and 17 (see page 19).

Technical Data

(Model 237–512 Bulldog Pump)

⚠ WARNING

Be sure that all fluids and solvents used are chemically compatible with the Wetted Parts listed below. Always read the manufacturer's literature before using fluid or solvent in this pump.

Ratio	21:1
Maximum fluid working pressure	145 bar (2100 psi)
Maximum air input pressure	7 bar (100 psi)
Pump cycles per 3.8 liters (1 gal.)	12.5
Fluid flow at 60 cycles/min	18.2 liters/min (4.8 gpm)
Air motor piston effective area	248 cm ² (38 in. ²)
Stroke length	120 mm (4.75 in.)
Displacement pump effective area	12 cm ² (1.86 in. ²)
Maximum pump operating temperature	82°C (180°F)
* Noise level at 100 psi, 25 cycles/min	94 dBA
* Sound power level at 100 psi, 25 cycles/min	109 dBA
Air inlet size	3/4 npsm(f)
Fluid inlet size	2" npt(f)
Fluid outlet size	1" npt(f)
Weight	approx. 109 kg (240 lb)
Wetted parts ..	Carbon Steel; Chrome Steel; Alloy Steel; Chrome, Zinc, and Nickel Plating; 440 and 17–4 PH Grades of Stainless Steel; Ductile Iron; Tungsten Carbide; PTFE; . Glass-Filled PTFE; Leather

* Tested in accordance with ISO 3744.

KEY: Fluid Outlet Pressure – Black Curves
Air Consumption – Gray Curves

A 7 bar (100 psi) Air Pressure
B 4.9 bar (70 psi) Air Pressure
C 2.8 bar (40 psi) Air Pressure

NOTE: Recommended pump speed for continuous operation (to shaded area): 60 cpm

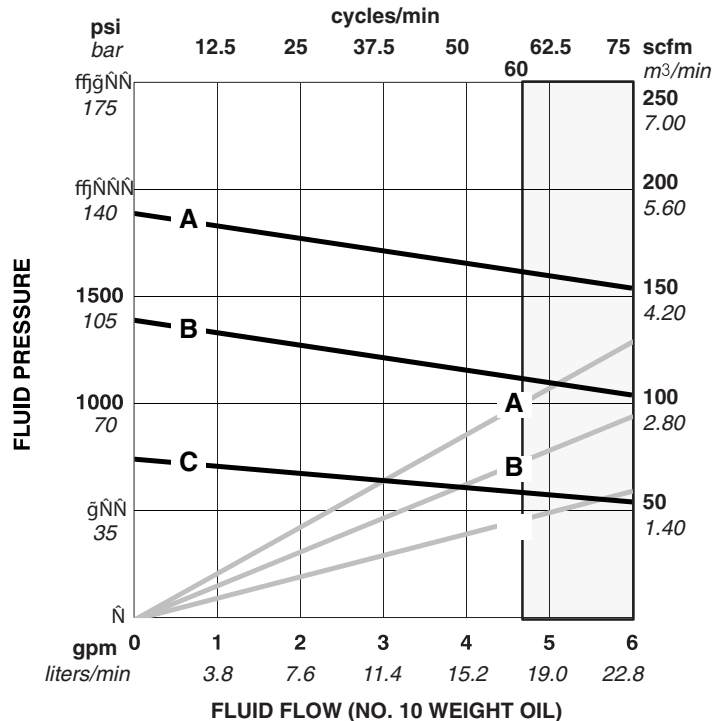

To find Fluid Outlet Pressure (bar/psi) at a specific fluid flow (lpm/gpm) and operating air pressure (bar/psi):

1. Locate desired flow along bottom of chart.
2. Follow vertical line up to intersection with selected fluid outlet pressure curve (black). Follow left to scale to read fluid outlet pressure.

To find Pump Air Consumption (m³/min or scfm) at a specific fluid flow (lpm/gpm) and air pressure (bar/psi):

1. Locate desired flow along bottom of chart.
2. Read vertical line up to intersection with selected air consumption curve (gray). Follow right to scale to read air consumption.

Technical Data

(Model 237–513 Senator Pump)

⚠ WARNING

Be sure that all fluids and solvents used are chemically compatible with the Wetted Parts listed below. Always read the manufacturer's literature before using fluid or solvent in this pump.

Ratio	13:1
Maximum fluid working pressure	90 bar (1300 psi)
Maximum air input pressure	7 bar (100 psi)
Pump cycles per 3.8 liters (1 gal.)	12.5
Fluid flow at 60 cycles/min	18.2 liters/min (4.8 gpm)
Air motor piston effective area	154 cm ² (24 in. ²)
Stroke length	120 mm (4.75 in.)
Displacement pump effective area	12 cm ² (1.86 in. ²)
Maximum pump operating temperature	82°C (180°F)
* Noise level at 100 psi, 25 cycles/min	93 dBa
* Sound power level at 100 psi, 25 cycles/min	108 dBa
Air inlet size	3/4 npsm(f)
Fluid inlet size	2" npt(f)
Fluid outlet size	1" npt(f)
Weight	approx. 109 kg (240 lb)
Wetted parts ..	Carbon Steel; Chrome Steel; Alloy Steel; Chrome, Zinc, and Nickel Plating; 440 and 17–4 PH Grades of Stainless Steel; Ductile Iron; Tungsten Carbide; PTFE [†] ; Glass-FilledPTFE [†] ; Leather

* Tested in accordance with ISO 3744.

KEY: Fluid Outlet Pressure – Black Curves
Air Consumption – Gray Curves

A 7 bar (100 psi) Air Pressure
B 4.9 bar (70 psi) Air Pressure
C 2.8 bar (40 psi) Air Pressure

NOTE: Recommended pump speed for continuous operation (to shaded area): 60 cpm

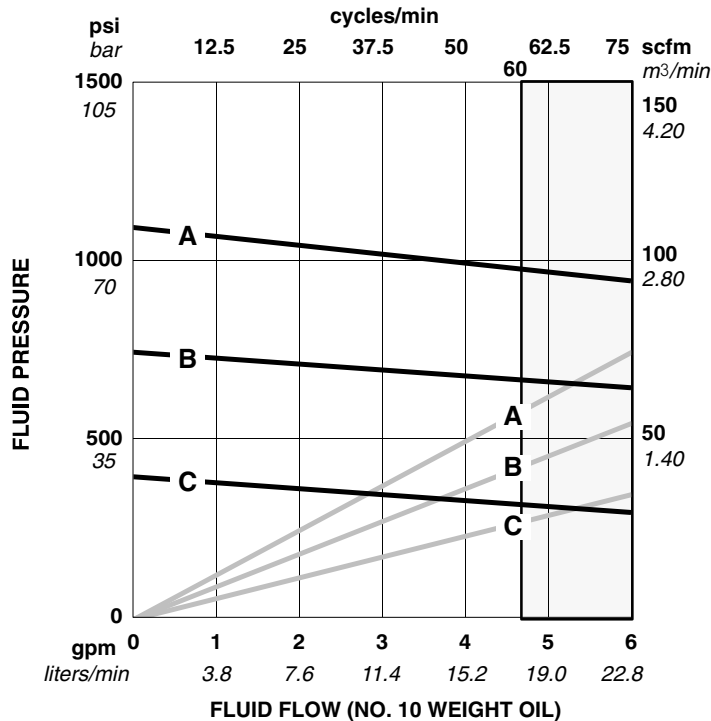

Dimensions

Model 237-512 Shown

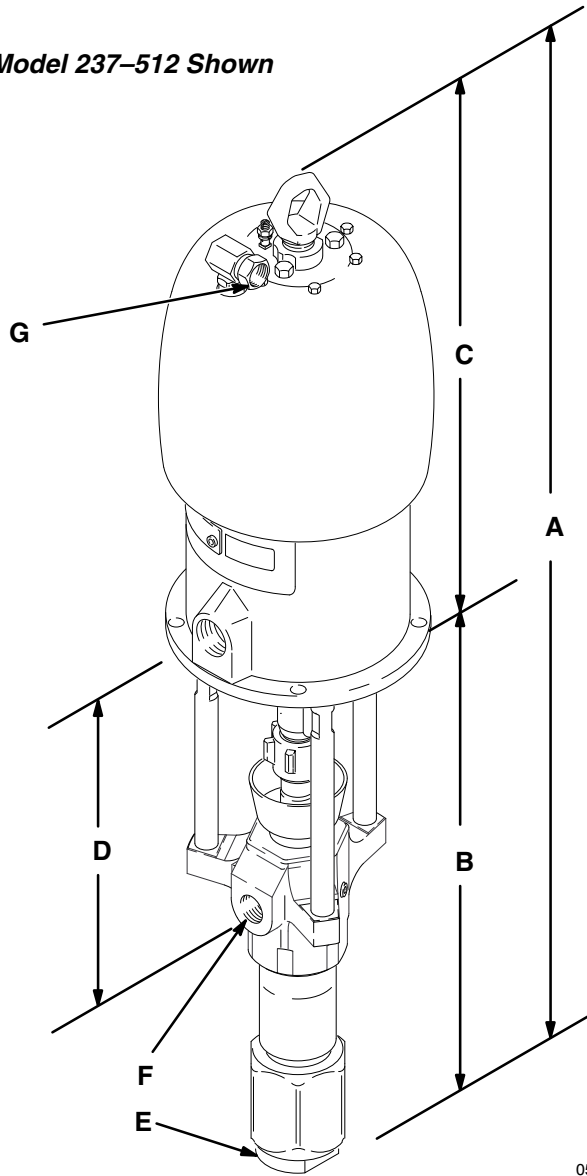

05196

Mounting Hole Layout

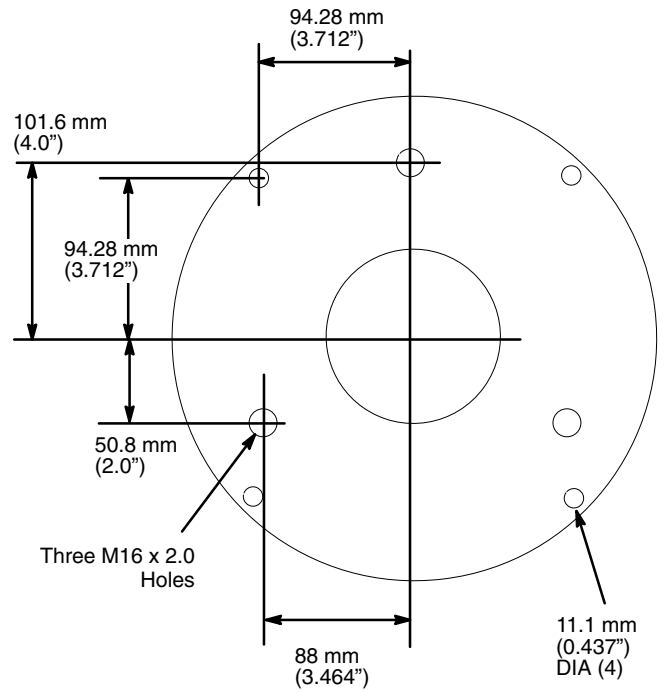

0653

Pump Model	A	B	C	D	E	F	G
237-512	1134 mm (44.65 in.)	590 mm (23.23 in.)	544 mm (21.42 in.)	257 mm (10.12 in.)	2 in. npt(f)	1 in. npt(f)	3/4 npsm(f)
237-513	1138 mm (44.80 in.)	590 mm (23.23 in.)	548 mm (21.57 in.)	257 mm (10.12 in.)	2 in. npt(f)	1 in. npt(f)	3/4 npsm(f)

Warranty

WARRANTY

Graco warrants all equipment manufactured by it and bearing its name to be free from defects in material and workmanship on the date of sale by an authorized Graco distributor to the original purchaser for use. As purchaser's sole remedy for breach of this warranty, Graco will, for a period of twelve months from the date of sale, repair or replace any part of the equipment proven defective. This warranty applies only when the equipment is installed, operated and maintained in accordance with Graco's written recommendations.

This warranty does not cover, and Graco shall not be liable for, any malfunction, damage or wear caused by faulty installation, misapplication, abrasion, corrosion, inadequate or improper maintenance, negligence, accident, tampering, or substitution of non-Graco component parts. Nor shall Graco be liable for malfunction, damage or wear caused by the incompatibility with Graco equipment of structures, accessories, equipment or materials not supplied by Graco, or the improper design, manufacture, installation, operation or maintenance of structures, accessories, equipment or materials not supplied by Graco.

This warranty is conditioned upon the prepaid return of the equipment claimed to be defective to an authorized Graco distributor for verification of the claim. If the claimed defect is verified, Graco will repair or replace free of charge any defective parts. The equipment will be returned to the original purchaser transportation prepaid. If inspection of the equipment does not disclose any defect in material or workmanship, repairs will be made at a reasonable charge, which charges may include the costs of parts, labor and transportation.

DISCLAIMERS AND LIMITATIONS

The terms of this warranty constitute purchaser's sole and exclusive remedy and are in lieu of any other warranties (express or implied), **including warranty of merchantability or warranty of fitness for a particular purpose**, and of any non-contractual liabilities, including product liabilities, based on negligence or strict liability. Every form of liability for direct, special or consequential damages or loss is expressly excluded and denied. In no case shall Graco's liability exceed the amount of the purchase price. Any action for breach of warranty must be brought within two (2) years of the date of sale.

EQUIPMENT NOT COVERED BY GRACO WARRANTY

Graco makes no warranty, and disclaims all implied **warranties of merchantability and fitness for a particular purpose**, with respect to accessories, equipment, materials, or components sold but not manufactured by Graco. These items sold, but not manufactured by Graco (such as electric motor, switches, hose, etc.) are subject to the warranty, if any, of their manufacturer. Graco will provide purchaser with reasonable assistance in making any claim for breach of these warranties.

Graco Phone Numbers

TO PLACE AN ORDER, contact your Graco distributor, or call this number to identify the distributor closest to you: **1-800-367-4023 Toll Free**

FOR TECHNICAL ASSISTANCE, service repair information or assistance regarding the application of Graco equipment: **1-800-543-0339 Toll Free**

Sales Offices: Atlanta, Chicago, Detroit, Los Angeles
Foreign Offices: Belgium, Canada, England, Korea, Switzerland, France, Germany, Hong Kong, Japan

GRACO INC. P.O. BOX 1441 MINNEAPOLIS, MN 55440-1441

PRINTED IN U.S.A. 308-359 September 1994, Revised June 1995