

HEAVY-DUTY STAINLESS STEEL **Agitators**

308371U

EN

Pneumatic agitator for mixing and maintaining suspension of industrial coatings. Intended to be used in tanks with fluid viscosities above 800 cP. Waterborne compatible. For professional use only.

100 psi (0.7 MPa, 7 bar) Maximum Working Pressure

See page 2 for model information and approvals.



Important Safety Instructions

Read all warnings and instructions in this manual before using the equipment. Save these instructions.

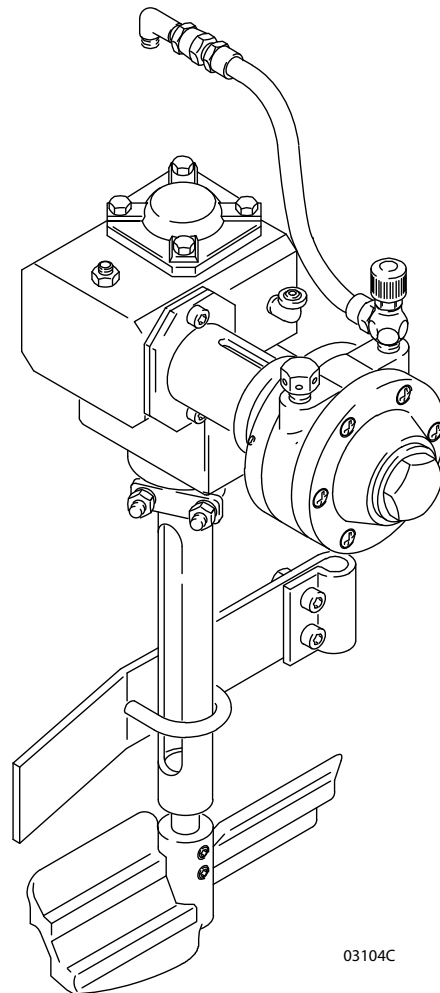



03104C

Model 236661

Contents

Models	2	Service	13
Related Manual	2	Replace the Heavy-Duty Air Motor.	13
Warnings	3	Replace the Heavy-Duty Gear Reducer.	14
Installation	5	Service the Agitator Shaft and Couplings	14
Air Requirements	5	Parts	16
Air Line Accessories	5	Stainless Steel, Heavy-Duty Agitators	16
Grounding	6	Models 236661 (5 gallon), 236662 (10 gallon),	
Install an Agitator onto a Non-Agitated Tank.	6	236663 (15 gallon)	16
Install a Heavy-Duty Agitator	7	Technical Specifications	18
Operation	9	California Proposition 65	18
Pressure Relief Procedure	9	Air Consumption Chart	19
Operate the Agitator.	10	Graco Standard Warranty	20
Maintenance	11		
Lubricate the Heavy-Duty Agitator	11		
Flush the Air Motor	11		
Air Motor Repair	12		
Clean the Shaft	12		
Agitator Blades	12		

Models









Tank Size gallons (liters)	Heavy Duty Agitator	Agency Approvals
5 (19)	236661	  II 1/2 G Ex h IIB T4 Ga/Gb CML 24ATEX6023X
10 (38)	236662	
15 (57)	236663	

Related Manual





Manuals in English	Description
308369	Stainless Steel 5-, 10-, and 15-Gallon Pressure Tanks Instruction manual

Warnings

The following warnings are for the setup, use, grounding, maintenance, and repair of this equipment. The exclamation point symbol alerts you to a general warning and the hazard symbols refer to procedure-specific risks. When these symbols appear in the body of this manual or on warning labels, refer back to these Warnings. Product-specific hazard symbols and warnings not covered in this section may appear throughout the body of this manual where applicable.

 <h1 style="margin: 0;">WARNING</h1>	
   	<p>FIRE AND EXPLOSION HAZARD</p> <p>Flammable fumes, such as solvent and paint fumes, in work area can ignite or explode. Paint or solvent flowing through the equipment can cause static sparking. To help prevent fire and explosion:</p> <ul style="list-style-type: none"> • Use equipment only in well-ventilated area. • Eliminate all ignition sources; such as pilot lights, cigarettes, portable electric lamps, and plastic drop cloths (potential static sparking). • Ground all equipment in the work area. See Grounding instructions. • Never spray or flush solvent at high pressure. • Keep work area free of debris, including solvent, rags and gasoline. • Do not plug or unplug power cords, or turn power or light switches on or off when flammable fumes are present. • Use only grounded hoses. • Hold gun firmly to side of grounded pail when triggering into pail. Do not use pail liners unless they are anti-static or conductive. • Stop operation immediately if static sparking occurs or you feel a shock. Do not use equipment until you identify and correct the problem. • Keep a working fire extinguisher in the work area.
 	<p>MOVING PARTS HAZARD</p> <p>Moving parts can pinch, cut or amputate fingers and other body parts.</p> <ul style="list-style-type: none"> • Keep clear of moving parts. • Do not operate equipment with protective guards or covers removed. • Do not wear loose clothing, jewelry or long hair while operating equipment. • Equipment can start without warning. Before checking, moving, or servicing equipment, follow the Pressure Relief Procedure and disconnect all power sources.
	<p>SPECIAL CONDITIONS FOR SAFE USE</p> <ul style="list-style-type: none"> • Electrostatic charging hazard. Clean surfaces with a damp cloth and read instructions for additional techniques to mitigate risk of electrostatic discharge. • The Ambient Temperature Range of each agitator depends on the air motor included in the assembly. Refer to Models and Technical Specifications in Instruction manual for additional information.

WARNING

 	<p>EQUIPMENT MISUSE HAZARD Misuse can cause death or serious injury.</p> <ul style="list-style-type: none"> • Do not operate the unit when fatigued or under the influence of drugs or alcohol. • Do not exceed the maximum working pressure or temperature rating of the lowest rated system component. See Technical Specifications in all equipment manuals. • Use fluids and solvents that are compatible with equipment wetted parts. See Technical Specifications in all equipment manuals. Read fluid and solvent manufacturer’s warnings. For complete information about your material, request Safety Data Sheets (SDSs) from distributor or retailer. • Do not leave the work area while equipment is energized or under pressure. • Turn off all equipment and follow the Pressure Relief Procedure when equipment is not in use. • Check equipment daily. Repair or replace worn or damaged parts immediately with genuine manufacturer’s replacement parts only. • Do not alter or modify equipment. Alterations or modifications may void agency approvals and create safety hazards. • Make sure all equipment is rated and approved for the environment in which you are using it. • Use equipment only for its intended purpose. Call your distributor for information. • Route hoses and cables away from traffic areas, sharp edges, moving parts, and hot surfaces. • Do not kink or over bend hoses or use hoses to pull equipment. • Keep children and animals away from work area. • Comply with all applicable safety regulations.
 	<p>TOXIC FLUID OR FUMES HAZARD Toxic fluids or fumes can cause serious injury or death if splashed in the eyes or on skin, inhaled, or swallowed.</p> <ul style="list-style-type: none"> • Read Safety Data Sheets (SDSs) to know the specific hazards of the fluids you are using. • Store hazardous fluid in approved containers, and dispose of it according to applicable guidelines.
	<p>PERSONAL PROTECTIVE EQUIPMENT Wear appropriate protective equipment when in the work area to help prevent serious injury, including eye injury, hearing loss, inhalation of toxic fumes, and burns. Protective equipment includes but is not limited to:</p> <ul style="list-style-type: none"> • Protective eyewear, and hearing protection. • Respirators, protective clothing, and gloves as recommended by the fluid and solvent manufacturer.

Installation

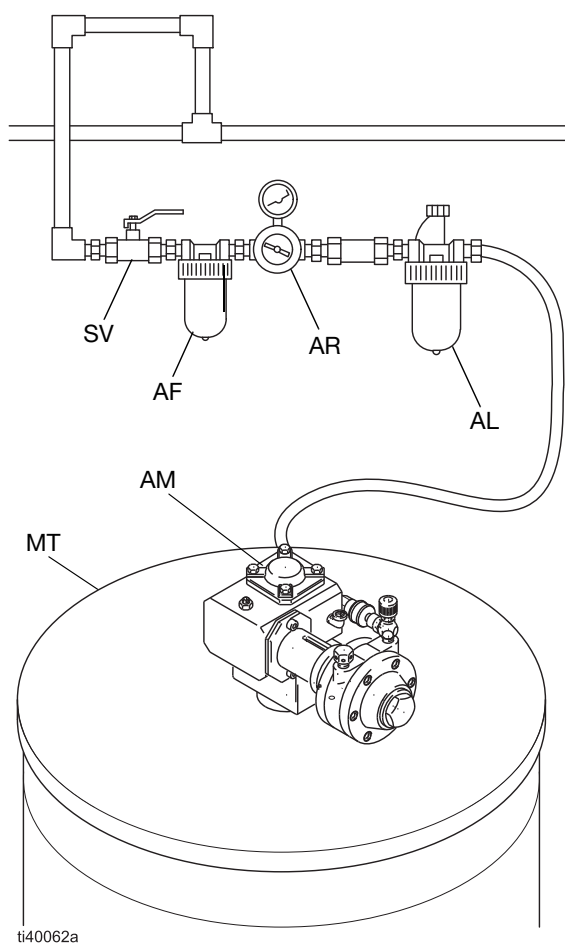
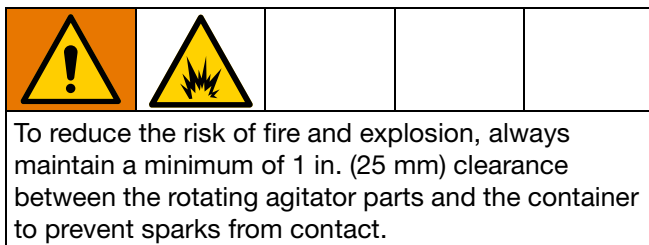

Fig. 1: Typical Installation

Key:

- SV: Bleed-type air shutoff valve
- AF: Air line filter
- AR: Air regulator and gauge
- AL: Air line lubricator
- AM: Agitator motor
- MT: Mix tank (reference only)

NOTE: Reference numbers and letters in parentheses refer to the callouts in the figures and in **Parts** on page 16.

Air Requirements

For continuous use, the 3/4 HP (550 W) agitator air motor requires 3 to 4 cfm (0.08 to 0.11 m³/min).

Air Line Accessories

A bleed-type air shutoff valve (SV) is required; it isolates the air line components for servicing. The air shutoff valve should be installed in the supply line and can be used to stop and start the agitator. If the valve is used to stop and start the agitator, you do not need to set the agitator speed each time it is used.

Order air shutoff valves by the part numbers listed below:

110223 1/4" npt(f) x 1/4" npt(f)

110224 3/8" npt(f) x 3/8" npt(f)

113333 3/8" npt(m) x 3/8" npt(f)

Install an air line filter (AF) to remove harmful dirt and moisture from the air supply. To order an air line filter, order by the part numbers listed below:

106148 3/8" npt, 20-micron element, 5 oz. bowl, without gauge

106146 1/2" npt, 40-micron element, 40 oz. bowl, 0 to 200 psi (0 to 14 bar) regulated pressure range

NOTICE

Not lubricating the air motor will cause air motor failure.

Downstream from the filter, install an air line lubricator (AL) for automatic air motor lubrication. Set the lubricator feed rate at 1 drop of oil per minute for high speed or continuous duty usage. Do not overfeed oil or exhaust air may become contaminated. To manually lubricate the air motor, see **Lubricate the Air Motor** on page 11. To order a 3/8" npt air line lubricator, order Part No. 214847.

Grounding

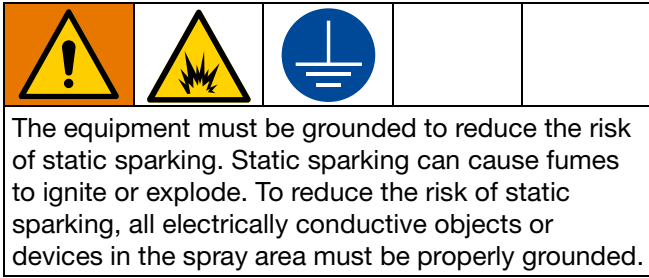

Check your local electrical code for detailed grounding instructions for your area and type of equipment.

To ground the agitator, connect one end of the ground wire (A) to the ground connector (B) on agitator mounting bracket (see FIG. 2). Connect the other end of the ground wire to a true earth ground.

For an additional ground wire and clamp, order part 237569.

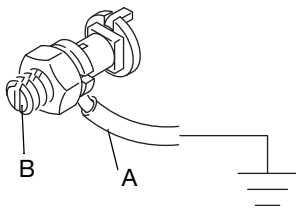

FIG. 2: Grounding

Install an Agitator onto a Non-Agitated Tank

1. Follow the **Pressure Relief Procedure**, page 9. Remove the tank cover from the tank.
2. Unscrew and remove the hex jam nut (C), plug (D), and O-ring (E) from the tank cover.
3. Place the gasket (17) on top of the tank cover center hole. Insert the agitator drive shaft (14) through the center hole.

NOTE: Position the air motor so it faces away from the air regulator mounting as shown in FIG. 3.

4. Install the jam nut (C) below the tank cover. Tighten the jam nut firmly to assure a seal between the gasket (17) and tank cover.
5. Install the shaft support (11) onto the shaft housing (9). Secure with U-bolt (26), clamp (10), lock washer (36) and nut (25).

6. Tighten the U-bolt in a position leaving a 0.015 in. (0.006 mm) clearance gap between the thrust washer and the top of the shaft support. See **Parts** on page 16.

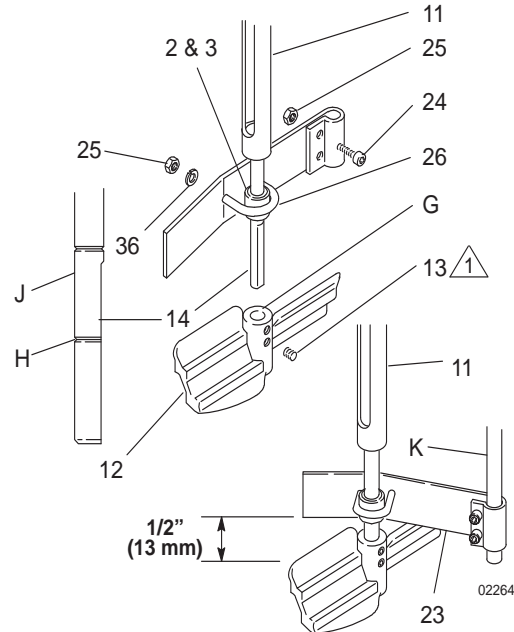

1 Apply low strength (cyanoacrylate) thread sealant.

7. **10 and 15 gallon tanks:** place the lower bearing assembly (2) and (3) on the shaft.
- 5 gallon tank:** clamp U-bolt directly to shaft support (11).
8. Slide the baffle (23) over the fluid tube (K) and position the baffle about 1/2 in. (13 mm) above the highest point on the agitator paddle (12).
9. Clamp the baffle in place with U-bolt (26), washer (36), and nut (25).
10. Align the agitator paddle (12) on the agitator shaft (14) as instructed for your model, as follows:

Models 236662 and 236663 (10 and 15 Gallon)
Align the top of the paddle hub (G) with the mark (H) on the agitator shaft (14).

Model 236661 (5 Gallon)

If a 5 gallon pail is to be placed inside the pressure tank (5 gallon tank only), align the top of the paddle hub (G) with the upper mark (J) on the agitator shaft (14).

- Apply low strength sealant to the two setscrews (13). Firmly secure the paddle with the setscrews.

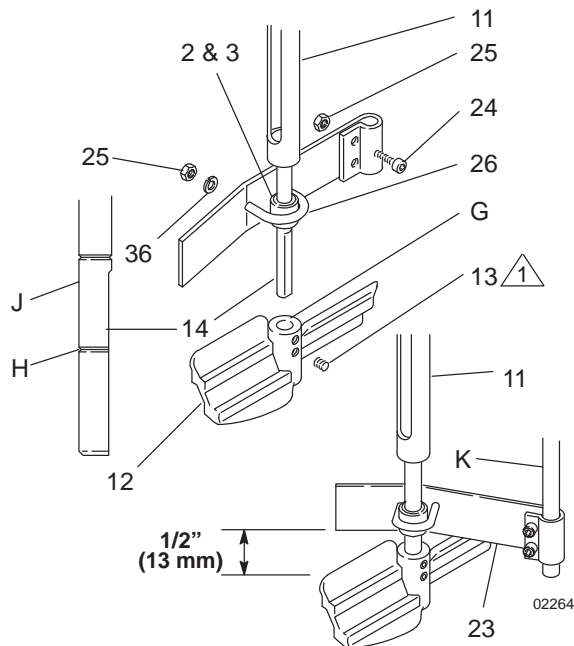

Apply low strength (cyanoacrylate) thread sealant.

- Refer to FIG. 4, page 10. Remove the plug from the air inlet manifold (N).
- Remove the elbow (37) from the end of the air hose (21) and attach to the pressure tank air inlet manifold (N).
- Connect the swivel end of the air hose (21) to the elbow (37).
- Remove the gear reducer oil level plug (L) from the street elbow and check the oil level in the reducer housing. The oil should never be higher than the oil level plug. If necessary, drain or add oil until the proper oil level is attained.
- Screw the oil level plug (L) back onto the street elbow (37).

NOTE: Special high temperature synthetic gear oil is required for the gear reducer. Use only Graco oil, part number 217374.

Install a Heavy-Duty Agitator

- Follow the **Pressure Relief Procedure**, page 9. Remove the pressure tank cover from the tank.
- Remove the upper U-bolt (26).

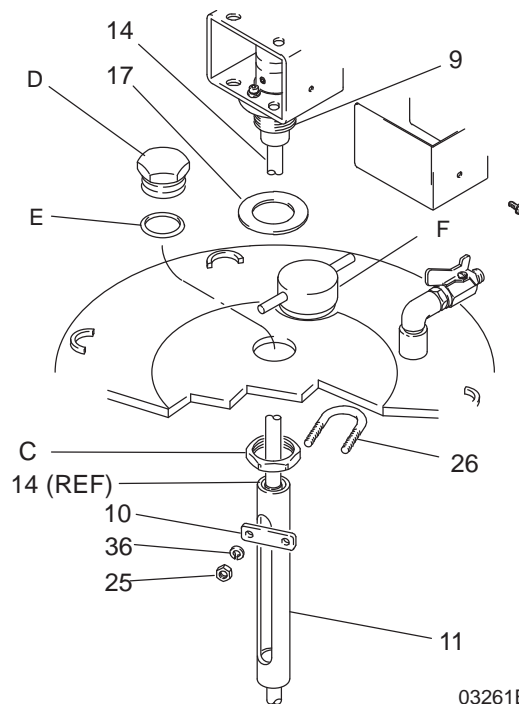

- Loosen the two set screws (13) and remove the agitator paddle (12).
 - On 10 and 15 gallon tanks:** remove the lower U-bolt (26), loosen screws (24) and slide the baffle (23) off the fluid tube (K).
 - Unscrew and remove the hex jam nut (C), gasket (17), and agitator from the tank cover.
 - Place the gasket (17) on top of the tank cover center hole. Insert the agitator drive shaft (14) through the center hole.
- NOTE:** Position the air motor so it faces away from the air regulator mounting as shown in FIG. 3, page 9.
- Install the jam nut (C) below the tank cover. Tighten the jam nut firmly to assure a seal between the gasket (17) and tank cover.
 - Install the shaft support (11) onto the shaft housing (9). Secure with U-bolt (26), clamp (10), lock washer (36) and nut (25).

9. Tighten the U-bolt in a position leaving a 0.015 in. (0.006 mm) clearance gap between the thrust washer and the top of the shaft support. Refer to **Parts**, page 16.
10. **10 and 15 gallon tanks:** place the lower bearing assembly (2) and (3) on the shaft.
5 gallon tank: clamp U-bolt directly to shaft support (11).
11. Slide the baffle (23) over the fluid tube (K) and position the baffle about 1/2 in. (13 mm) above the highest point on the agitator paddle (12).
12. Clamp the baffle in place with U-bolt (26), washer (36), and nut (25).
13. Align the agitator paddle (12) on the agitator shaft (14) as instructed for your model:

NOTE: Minimum of 1 in. (2.5 cm) clearance on all sides of agitator blades is required. When mounted correctly in Graco drum cover, this clearance should be met.

Models 236662 and 236663 (10 and 15 Gallon)
Align the top of the paddle hub (G) with the mark (H) on the agitator shaft (14).

Model 236661 (5 Gallon)
If a 5 gallon pail is to be placed inside the pressure tank (5 gallon tank only), align the top of the paddle hub (G) with the upper mark (J) on the agitator shaft (14). If a pail will not be placed inside the tank, align top of hub (G) with the lower mark (H) on the agitator shaft (14).

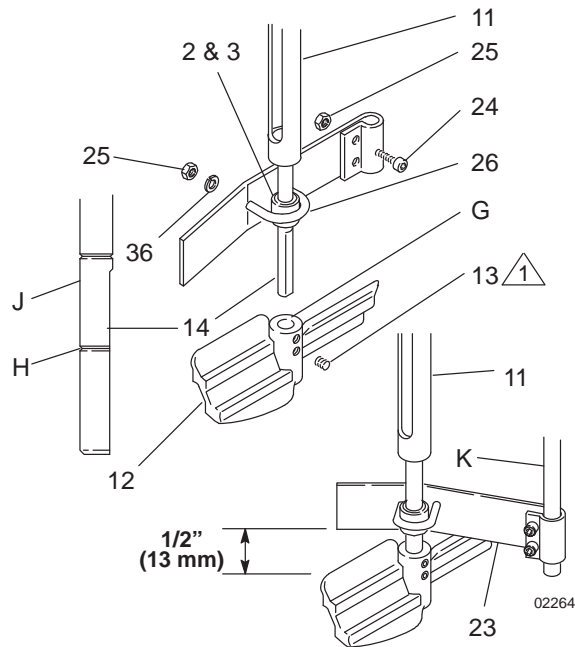



 Apply low strength (cyanoacrylate) thread sealant.

14. Refer to FIG. 4, page 10. Connect the swivel end of the air hose (21) to the elbow (37).
15. Remove the gear reducer oil level plug (L) from the street elbow and check the oil level in the reducer housing. The oil should never be higher than the oil level plug. If necessary, drain or add oil until the proper oil level is attained. Screw the oil level plug back onto the street elbow.





NOTE: Special high temperature synthetic gear oil is required for the gear reducer. Use only Graco oil, part number 217374.

Operation

				
<p>To reduce the risk of serious bodily injury, which can result if the tank pressure is not fully relieved, always follow the Pressure Relief Procedure before opening the tank cover or fill port.</p>				

				
<p>Over-pressurizing the tank or accessories could cause a part to rupture. To reduce the risk of serious injury, including splashing in the eyes or on the skin, or property damage, never exceed the maximum air and fluid working pressure of the lowest rated component in your system.</p>				

Pressure Relief Procedure

				
<p>This equipment stays pressurized until pressure is manually relieved. To help prevent serious injury from splashing fluid and moving parts, which can result if the tank pressure is not fully relieved, always follow the Pressure Relief Procedure before opening the pressure tank cover or fill port, cleaning, checking, or servicing the equipment.</p>				

1. Close the bleed-type air shutoff valve (SV) to relieve pressure to the air motor.
2. Turn the drain cock fitting (U) counterclockwise to open it.

NOTE: Wait until there is no air escaping through the fitting before removing the cover or opening the fill port.

3. Leave the drain cock fitting (U) open until the cover or filler cap have been reinstalled.

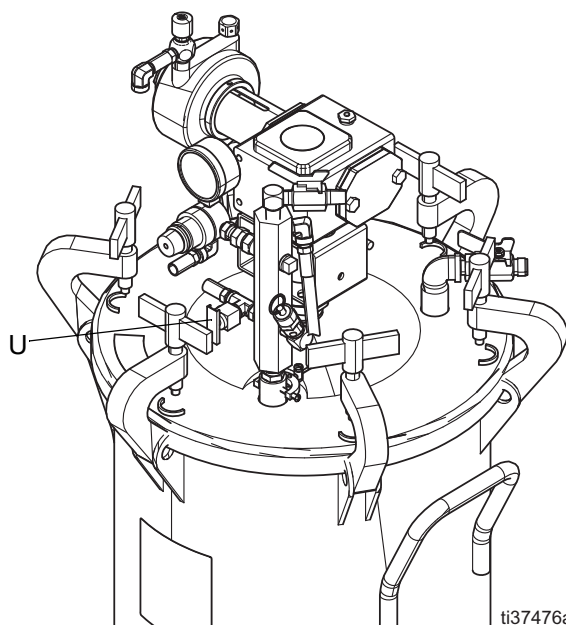

FIG. 3: 5 Gallon Tank with Heavy-Duty Agitator

ti37476a

Operate the Agitator

NOTICE

To avoid damaging the equipment, do not operate the agitator at a high speed for a long period of time. Excessive agitator speed can cause foaming of fluid (making the fluid unusable), vibration, and increased wear on parts. Agitate the fluid only enough to maintain even mixing.

NOTE: Use liquids with conductivity greater than 1000 pS/m.

1. Fill the pressure tank as explained in your Stainless Steel 5-, 10-, and 15-Gallon Pressure Tanks instruction manual.
2. Refer to FIG. 4. Screw on the filler cap (F), or if the tank cover was removed, place the agitator and cover on the pressure tank and secure the cover with the c-clamp handles (M).
3. Close the tank air regulator(s) by turning the knob(s) counterclockwise. Turn on the air supply.
4. To start the agitator, slowly open the needle valve (20). Adjust the speed of the agitator with the needle valve to about 40 to 60 rpm.
5. To stop the agitator, close the bleed-type air shutoff valve (SV) or close the needle valve (20).

Stop the agitator before removing it from the pail.

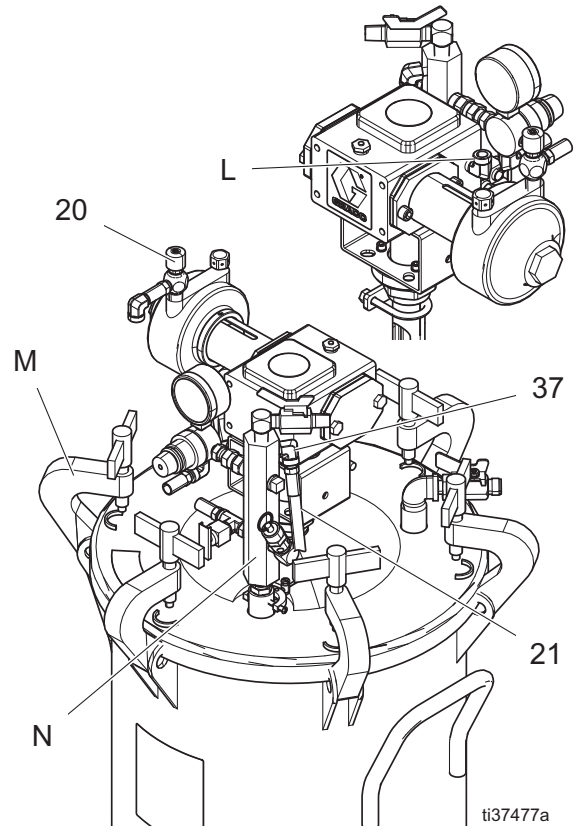

FIG. 4

ti37477a

Maintenance



To reduce the risk of serious bodily injury, including cuts, amputation of fingers, and splashing in the eyes or on the skin, always follow the **Pressure Relief Procedure**, shut off the agitator, and disconnect the air line before checking or repairing the agitator.

Lubricate the Heavy-Duty Agitator

NOTICE

To prevent air motor failure or gear reducer failure and possible damage to the agitator assembly, always keep the air motor and gear reducer properly lubricated.

Lubricate the Air Motor

Install an air line lubricator for automatic air motor lubrication. Set the lubricator feed rate at 1 drop of oil per minute for high speed or continuous duty usage. Do not overfeed oil or exhaust air may become contaminated. To order a 3/8 in. npt air line lubricator, order part number 214847.

If an air line lubricator is not installed, the air motor must be manually lubricated every 8 hours. Lubricate the agitator air motor by placing 10–20 drops of SAE #10 light oil in the motor's air inlet. Oil must have an auto-ignition rating of 275°F (135°C) or greater. Run the agitator for about 30 seconds.

Lubricate the Gear Reducer

Refer to FIG. 5, page 13. Remove the oil plug (T) and the oil level plug (L), drain the oil, and thoroughly flush the housing with light flushing oil. Refill with Graco oil (part number 217374) to the proper level.

Afterward, change the oil every six months or 2500 hours of operation (whichever occurs first) under normal operating conditions. More frequent oil changes are needed under severe operating conditions or in atmospheres containing excessive moisture or abrasives. Contact your Graco distributor.

Flush the Air Motor

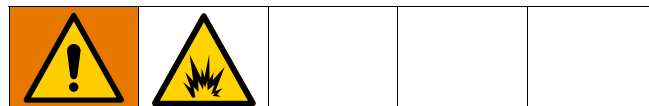

Do not use kerosene or other flammable solvents to flush the air motor. Flushing with flammable solvents could cause fire or explosion and result in serious injury or property damage.



Hazardous fluids or toxic fumes can cause serious injury or death if splashed in the eyes or on the skin, swallowed, or inhaled. When flushing the air motor:

- Flush the air motor in a ventilated area.
- Keep your face away from the exhaust port.
- Wear the appropriate protective clothing, gloves, eyewear, and respirator.

If the air motor is sluggish or inefficient, perform the following procedures.

The recommended solvent for air motors and lubricated pumps is Gast® Flushing Solvent (Gast part number AH255 or AH255A) or Inhibisol® Safety Solvent.

1. Disconnect the air line and muffler (22). See **Parts** on page 16.
2. Add several teaspoons of solvent or spray the solvent directly into the motor.
3. Rotate the shaft by hand in both directions for a few minutes.
4. Reconnect the air line, and slowly increase the air pressure until there is no trace of solvent in the exhaust air.
5. Re-lubricate the motor with a squirt of light-weight oil in the chamber.

Air Motor Repair



If the vanes need replacing, or if foreign material is present in the motor chamber, an experienced mechanic may remove the end plate opposite the drive shaft end. Do not pry with a screwdriver. It will dent the surface of the plate and body, causing leaks. Use a puller tool, which will remove the end plate while maintaining the position of the shaft.

New vanes should have the edges with cut corners (or the notched edges, if the vanes are reversible) pointing toward the bottom of the vane slot.

Clean the Shaft

Every week, clean any dried fluid from around the bearing (38) area of the shaft (14).

Agitator Blades

				
Materials can become electrostatically charged when stirred or blended. To prevent fire and explosion, ground equipment and do not allow material to build up on agitator. Dried material could allow static build up and interfere with grounding.				

Regularly check the agitator for dried material buildup. Clean using a rag soaked in solvent that is compatible with the spray material and the surfaces being cleaned. Additionally, extra precautions need to be taken if using lower conductive materials (<1000 pS/m) such as:

- Avoid stirring/mixing at high speeds.
- Avoid insoluble mixtures.
- When possible, increase the material conductivity with additives.
- Use liquids with a high conductivity (>1000 pS/m).

Service

Replace the Heavy-Duty Air Motor

Remove the Heavy-Duty Air Motor

1. Disconnect the air hose (21).
2. Loosen the two setscrews (32) on the collar (2) and remove the air motor (1).

Install the Heavy-Duty Air Motor

1. Place one-half of the coupling (3a) on the air motor shaft (S), flush with the end of the shaft. Tighten the coupling setscrew against the flat on the shaft.
2. Install the load cushion (P) on the gear reducer coupling half. Slide the clamp (2) onto the collar (4).
3. Align the two coupling halves (3a), and push the air motor hub into the collar (4) until it bottoms out, then back it out 0.015 in. (0.38 mm). Make sure the air motor inlet and outlet face up.
4. Apply Loctite™ Number 222 to the two clamp setscrews (32). Align the setscrews to one side of the slots on the collar (4), and tighten them.

5. Apply pipe thread sealant to the inlet (20) and outlet (22) fittings, and install them in the air motor.

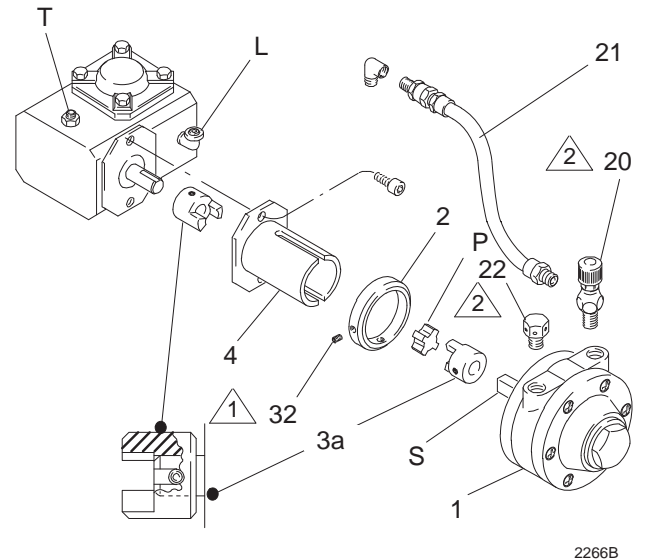

- 1 Apply Loctite Number 222.
 2 Apply low-strength thread sealant.

FIG. 5

Replace the Heavy-Duty Gear Reducer

Do not attempt to repair the gear reducer (5) yourself. Contact your Graco distributor.

Refer to FIG. 6, page 15.

1. When replacing the gear reducer, turn it upside down and remove the cap screws (33) and washers (40) from the bottom of the old gear reducer.
2. Remove the top coupling half (19a) from the old gear reducer, and install the coupling half on the new gear reducer. Wipe the screw holes clean with a rag.
3. Apply Loctite Number 271, or equivalent, to the four cap screws (33).
4. Install the cap screws (33) with the washers (40) through the bracket (6) and into the gear reducer. Make sure the three hole pattern on the bottom of the bracket (6) is orientated in relation to the gear reducer (5) as shown in FIG. 6, page 15.
5. Run the agitator to let the bracket (6) center itself. Torque the screws to 160 in-lb (18 N•m).
6. Leave the gear reducer upside down for 30 minutes to allow the Loctite to cure.
7. Set the coupling as instructed under **Set the Agitator Shaft Coupling**, on page 14.

NOTE: Do not use the four screws supplied with the replacement gear reducer to secure it; those screws will not properly secure the gear reducer. Use the cap screws and washers (33 and 40) removed from the old gear reducer. Be careful not to spill any oil from the gear reducer.

Service the Agitator Shaft and Couplings

Set the Agitator Shaft Coupling

1. With the agitator shaft (14) pushed up against the washer (15a), secure the lower portion of the coupling half (19b) to the shaft by tightening the coupling setscrew against the flat on the shaft. Leave about a 0.015 in. gap between the coupling half and washer (15b).
2. Secure the upper coupling half (19a) to the gear reducer shaft by tightening the coupling setscrew into the keyway. Leave about a 0.015 in. gap between each of the coupling halves (19a, 19b) and the load cushion (R).

Replace the Agitator Shaft

1. Remove the agitator paddle. Remove the setscrew from the lower coupling (19b). Pull out the agitator shaft (14) and install the new shaft.
2. Replace the agitator paddle.
3. With the agitator shaft (14) pushed up against the washer (15a), secure the lower portion of the coupling half (19b) to the shaft by tightening the coupling setscrew against the flat on the shaft. Leave about a 0.015 in. gap between the coupling half and washer (15b).

Replace the Coupling

1. Remove the three cap screws (18), washers (7) and spacers (8) from the mounting bracket (6).
2. Lift the air motor and gearbox off the tank cover. Remove the two coupling halves (19a, 19b) from the shaft ends.
3. Install the new coupling halves on the shaft ends. Replace the air motor/bracket assembly and the three cap screws (18), washers (7) and spacers (8) to fasten the mounting bracket.

Replace the Shaft Seals

1. Remove the three cap screws (18), washers (7), and spacers (8) from mounting bracket (6), and move the air motor assembly.
2. With air motor assembly removed, remove the setscrew from the lower coupling half (19b). Pull out the agitator shaft (14).
3. Remove the hex nut (16) and remove the shaft housing (9). Remove the seals (9a, 9b) from the shaft housing, and install the new seals.
4. Reinstall the shaft housing and shaft. Use installation steps listed in **Set the Agitator Shaft Coupling**, page 14.

NOTE: Check bearing and agitator for wear during recommended weekly cleaning. Replace worn parts with proper Graco replacement parts.

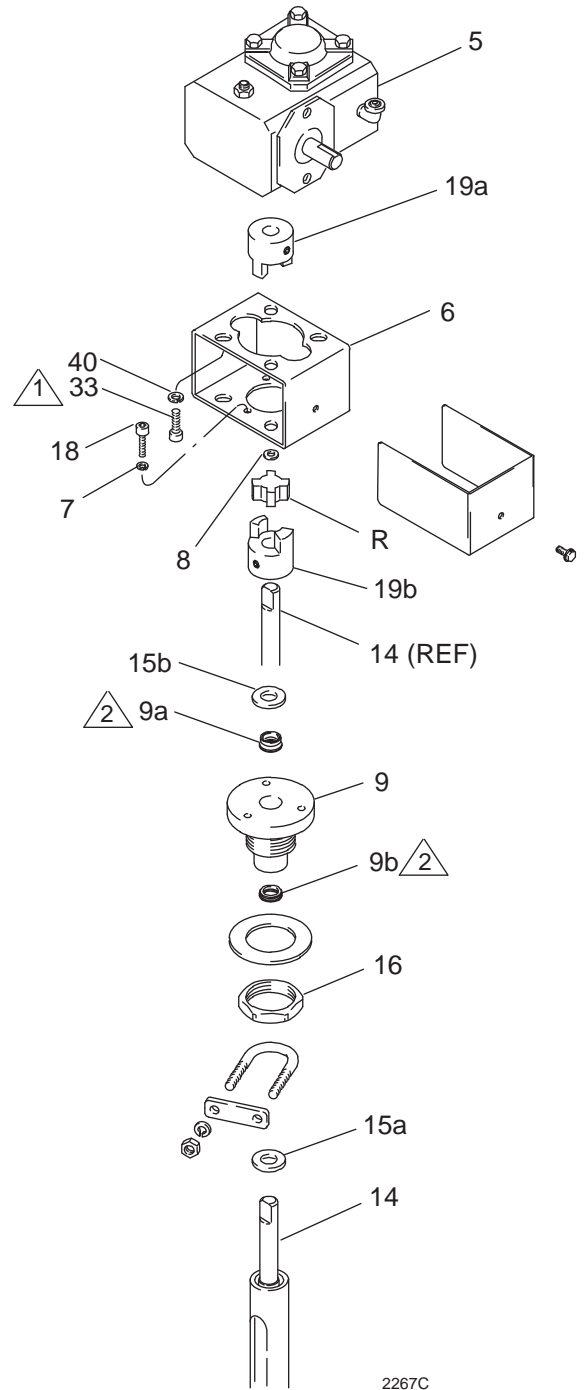

1 Apply Loctite Number 271.
Torque to 160 in-lb (18 N·m)

2 Install seals with open spring-loaded side toward tank

FIG. 6: Gear Reducer

Parts

Stainless Steel, Heavy-Duty Agitators

Models 236661 (5 gallon), 236662 (10 gallon), 236663 (15 gallon)

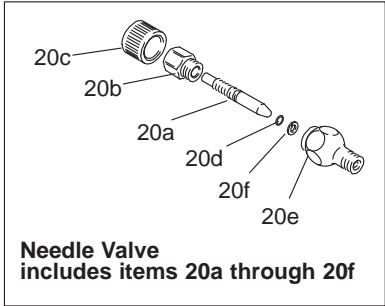
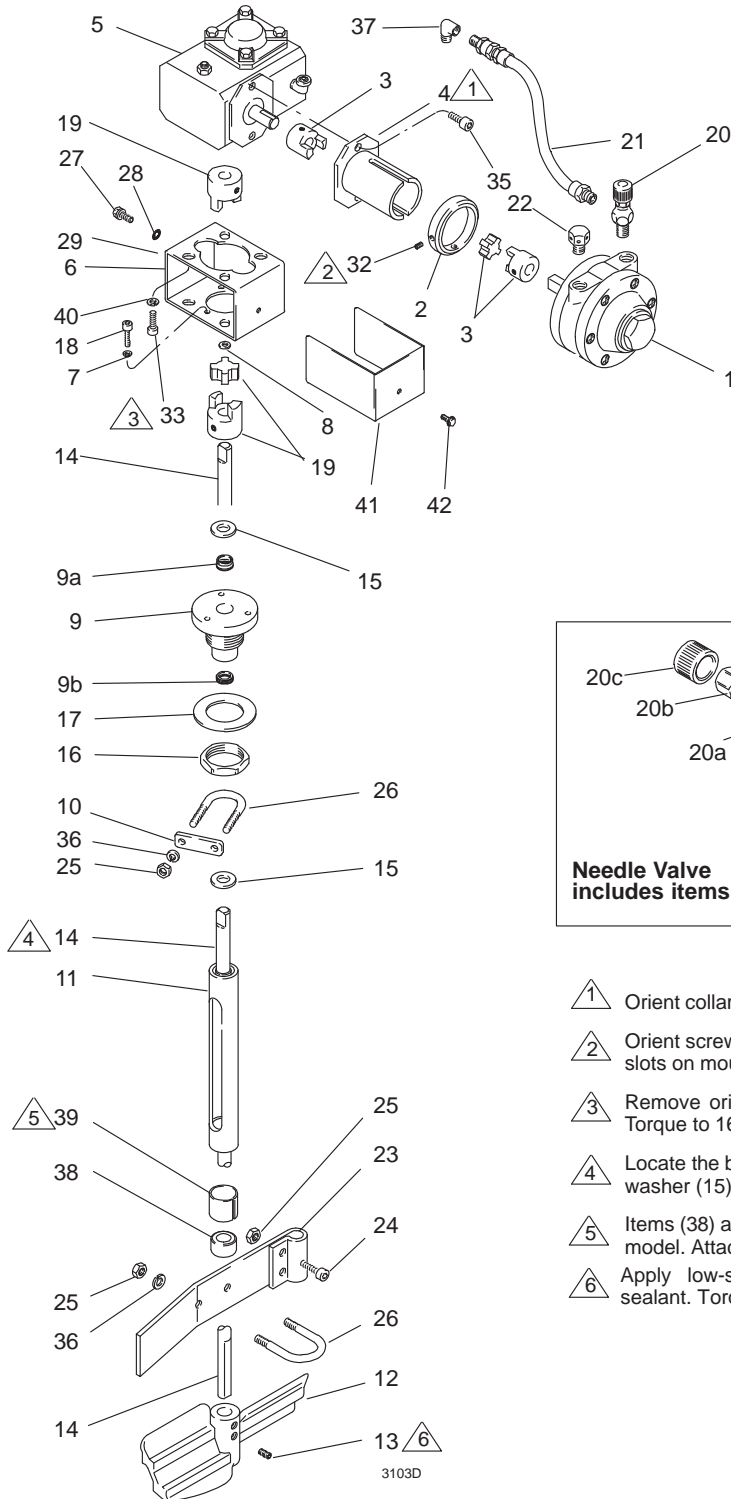

- 1 Orient collar (4) with slots facing up and down.
- 2 Orient screws (32) on collar (2) to either side of slots on mounting collar (4).
- 3 Remove original bolts, and replace with (33). Torque to 160 in-lbs (18 N-m).
- 4 Locate the bottom shoulder of shaft (14) against washer (15) when assembling coupler (19).
- 5 Items (38) and (39) are not used on the 5-gallon model. Attach item (26) to (11) for this model.
- 6 Apply low-strength (cyanoacrylate) thread sealant. Torque to 34-40 in-lbs. (4-4.5 N-m).

Stainless Steel, Heavy-Duty Agitators

Ref.	Part	Description	Qty.	Ref.	Part	Description	Qty.
1	162425	MOTOR, air	1	20d	157628	O-RING; buna-N	1
2	181849	COLLAR	1	20e	165722	BODY, valve	1
3	100828	COUPLING, flexible	1	20f	166531	WASHER, nylon	1
4	220416	COLLAR, mounting; Includes items 4a & 4b	1	21	160023	HOSE, coupled; 400 psi (2.8 MPa, 28 bar) maximum working pressure	1
4a	181848	SLEEVE, mounting, air motor	1	22	156969	MUFFLER, exhaust	1
4b	170751	PLATE, mounting	1	23	171989	BAFFLE, agitator, sst	1
5	181794	REDUCER, gear	1	24	112222	SCREW, cap, socket head; 1/4-20 x 1 in., (25 mm) sst	2
6	181749	BRACKET, mounting	1	25	112223	NUT, hex, regular; 1/4-20, (19 mm) sst	6
7	100020	WASHER, lock	1	26	110278	U-BOLT, clamp; sst	2
8	108462	SPACER	1	27	111593	SCREW, grounding	1
9	236092	HOUSING, shaft; Includes replaceable items 9a & 9b	1	28	157021	WASHER, lock, internal	1
9	103553	SEAL, shaft	1	29s	186620	LABEL, grounding symbol	1
9	104431	SEAL, shaft	1	30s	17P806	LABEL, warning (not shown)	1
10	112533	CLAMP, plate, sst	1	32	101118	SCREW, set, sch; 10-24 x 0.25 in. (6 mm) long	2
11	210576	SUPPORT, shaft; Includes replaceable item 38	1	33	110298	SCREW, cap, sch; 1/4-20 x 0.875 in. (22 mm) long	4
12*	236098	PADDLE, agitator; plastic	1	35	116940	SCREW, cap; 5/16-18 x 1/2 in. (13 mm) long	2
13	131497	SCREW, set, cup, pt, 1/4-20 x 0.5 in. (13 mm)	2	36	104123	WASHER, lock, sst	4
14	188886	SHAFT, agitator, 15 in., 5 gal size (18.9 liters); sst	1	37	112307	ELBOW, street; 90- x 1/8-27 npt(f) 1/8-27 npt(m)	1
14	188887	SHAFT, agitator, 20.75 in., 10 gal size (37.8 liters); sst	1	38	171970	BEARING PTFE; Included with Models 236662 and 236663 only	1
14	188888	SHAFT, agitator, 31 in., 15 gal size (56.7 liters); sst	1	39	187324	HOUSING, bearing; Included with Models 236662 and 236663 only; sst	1
15	104373	WASHER, thrust; 1/2 in. ID x 1 in. OD	1	40	170772	WASHER, flat; 0.26 x 0.69 dia; sst	4
16	188784	NUT, jam, hex; 1-1/2 in.-12; stainless steel	2	41	194701	GUARD	1
17	196309	GASKET, LDPE foam	1	42	100078	SCREW, #8-32x3/8 in.	1
18	102598	SCREW, cap, socket head; 10-32 x 0.5 in. (13 mm)	3				
19	108463	COUPLING, flexible	1				
20	206264	VALVE, needle; Includes items 20a to 20f	1				
20a	166529	NEEDLE, valve	1				
20b	166532	NUT, packing	1				
20c	164698	KNOB, packing	1				

* Stainless steel agitator paddle 186517, 304 stainless steel welded construction, replaces plastic agitator paddle 236098.

s Replacement safety labels, tags, and cards are available at no cost.

Technical Specifications

Heavy-Duty Stainless Steel Agitators		
	US	Metric
Air motor	Air driven, gear reduced, 1/2 HP (373 W)	
Maximum air pressure	100 psi	0.7 MPa, 7 bar
Ambient operating temperature range	+33.8°F < Ta < +104°F	+1°C < Ta < +40°C
Gear ratio	Reduced 20:1; shaft rpm is 1/20 of air motor rpm	
Weight	21.0 lb	9.5 kg
Wetted Parts	304 and 316 stainless steel, PTFE, Zytel, and bronze	
Noise (dBa)		
Sound pressure		
At no load at maximum rpm	83.4 dB(A)	
Under load at 50 rpm	64.0 dB(A)	
Sound power		
At no load at maximum rpm	96.6 dB(A)	
Under load at 50 rpm	77.2 dB(A)	
<i>Sound pressure measured 3 feet (1 meter) from equipment.</i>		
<i>Sound power measured per CAGI-PNEUROP, 1971.</i>		
Notes		
All trademarks or registered trademarks are the property of their respective owners.		

California Proposition 65

CALIFORNIA RESIDENTS

 **WARNING:** Cancer and reproductive harm – www.P65warnings.ca.gov.

Air Consumption Chart

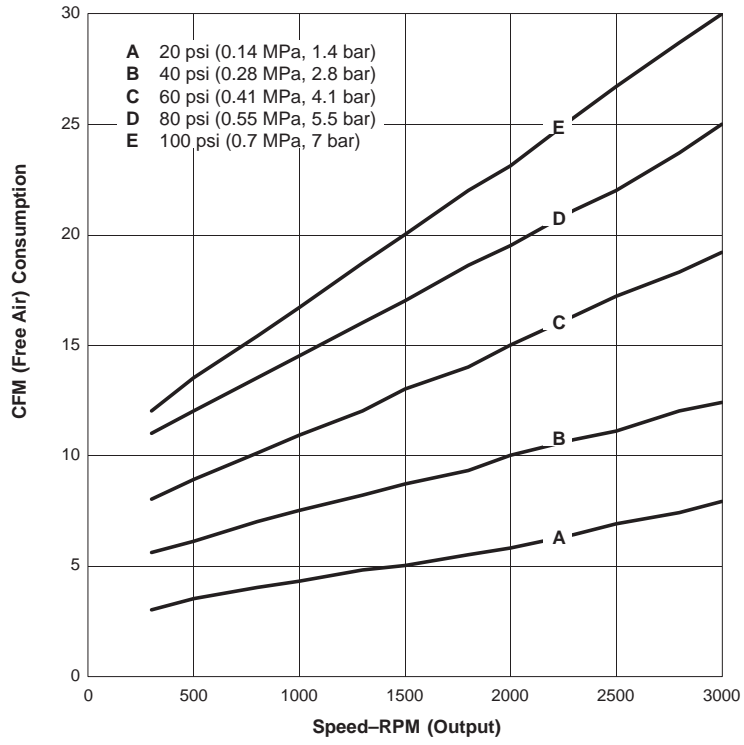

Graco Standard Warranty

Graco warrants all equipment referenced in this document which is manufactured by Graco and bearing its name to be free from defects in material and workmanship on the date of sale to the original purchaser for use. With the exception of any special, extended, or limited warranty published by Graco, Graco will, for a period of twelve months from the date of sale, repair or replace any part of the equipment determined by Graco to be defective. This warranty applies only when the equipment is installed, operated and maintained in accordance with Graco's written recommendations.

This warranty does not cover, and Graco shall not be liable for general wear and tear, or any malfunction, damage or wear caused by faulty installation, misapplication, abrasion, corrosion, inadequate or improper maintenance, negligence, accident, tampering, or substitution of non-Graco component parts. Nor shall Graco be liable for malfunction, damage or wear caused by the incompatibility of Graco equipment with structures, accessories, equipment or materials not supplied by Graco, or the improper design, manufacture, installation, operation or maintenance of structures, accessories, equipment or materials not supplied by Graco.

This warranty is conditioned upon the prepaid return of the equipment claimed to be defective to an authorized Graco distributor for verification of the claimed defect. If the claimed defect is verified, Graco will repair or replace free of charge any defective parts. The equipment will be returned to the original purchaser transportation prepaid. If inspection of the equipment does not disclose any defect in material or workmanship, repairs will be made at a reasonable charge, which charges may include the costs of parts, labor, and transportation.

THIS WARRANTY IS EXCLUSIVE, AND IS IN LIEU OF ANY OTHER WARRANTIES, EXPRESS OR IMPLIED, INCLUDING BUT NOT LIMITED TO WARRANTY OF MERCHANTABILITY OR WARRANTY OF FITNESS FOR A PARTICULAR PURPOSE.

Graco's sole obligation and buyer's sole remedy for any breach of warranty shall be as set forth above. The buyer agrees that no other remedy (including, but not limited to, incidental or consequential damages for lost profits, lost sales, injury to person or property, or any other incidental or consequential loss) shall be available. Any action for breach of warranty must be brought within two (2) years of the date of sale.

GRACO MAKES NO WARRANTY, AND DISCLAIMS ALL IMPLIED WARRANTIES OF MERCHANTABILITY AND FITNESS FOR A PARTICULAR PURPOSE, IN CONNECTION WITH ACCESSORIES, EQUIPMENT, MATERIALS OR COMPONENTS SOLD BUT NOT MANUFACTURED BY GRACO. These items sold, but not manufactured by Graco (such as electric motors, switches, hose, etc.), are subject to the warranty, if any, of their manufacturer. Graco will provide purchaser with reasonable assistance in making any claim for breach of these warranties.

In no event will Graco be liable for indirect, incidental, special or consequential damages resulting from Graco supplying equipment hereunder, or the furnishing, performance, or use of any products or other goods sold hereto, whether due to a breach of contract, breach of warranty, the negligence of Graco, or otherwise.

FOR GRACO CANADA CUSTOMERS

The Parties acknowledge that they have required that the present document, as well as all documents, notices and legal proceedings entered into, given or instituted pursuant hereto or relating directly or indirectly hereto, be drawn up in English. Les parties reconnaissent avoir convenu que la rédaction du présente document sera en Anglais, ainsi que tous documents, avis et procédures judiciaires exécutés, donnés ou intentés, à la suite de ou en rapport, directement ou indirectement, avec les procédures concernées.

Graco Information

For the latest information about Graco products, visit www.graco.com.

For patent information, see www.graco.com/patents.

TO PLACE AN ORDER, contact your Graco distributor or call to identify the nearest distributor.

Phone: 612-623-6921 **or Toll Free:** 1-800-328-0211, **Fax:** 612-378-3505

All written and visual data contained in this document reflects the latest product information available at the time of publication. Graco reserves the right to make changes at any time without notice.

Original instructions. This manual contains English. MM 308371

Graco Headquarters: Minneapolis

International Offices: Belgium, China, Japan, Korea

GRACO INC. AND SUBSIDIARIES • P.O. BOX 1441 • MINNEAPOLIS MN 55440-1441 • USA
Copyright 1994, Graco Inc. All Graco manufacturing locations are registered to ISO 9001.

www.graco.com
Revision U, February 2024