

Split Manifold Kits

308439E

EN

Converts Husky™ 307 Diaphragm Pump to dual fluid inlet or outlet

Part No. 237210

For Husky 307 Polypropylene Pumps

Part No. 237211

For Husky 307 Acetal Pumps



Important Safety Instructions

Read all warnings and instructions in the manual. Save these instructions.

Installation

The Split Manifold Kit enables you to convert the Husky 307 Pump to a dual fluid inlet manifold, dual fluid outlet manifold, or both. See Figs. 1, 2, and 3 for some applications. To install the kit, see page 3.

NOTE: To convert both the inlet and the outlet manifold, two kits are required.

TRAY FILL INSTALLATION Uses dual inlet and dual outlet manifolds.

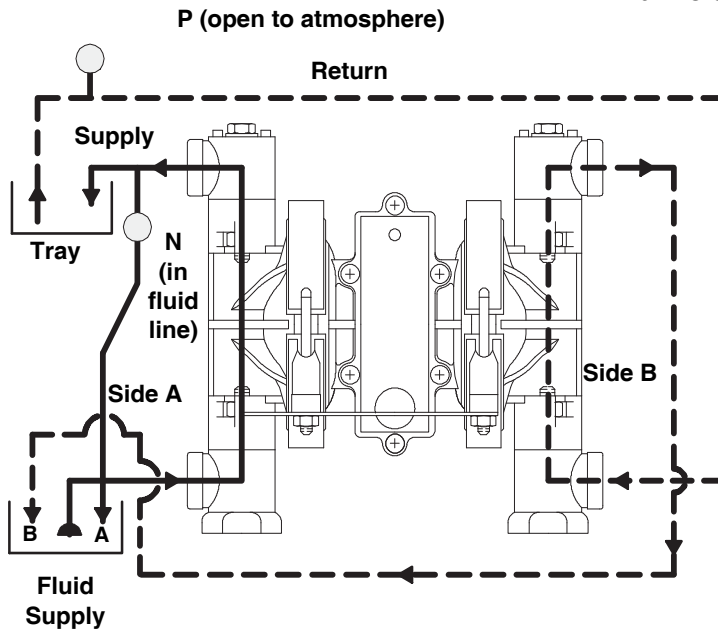

System Explanation

In this installation, fluid is drawn from the supply container into one of the manifold inlets. With the fluid needle valve (N) closed, the fluid is pumped through side A and out to the tray. Opening the air side needle valve (P) draws air into the fluid return line so less fluid is returned to the pump (side B) than is supplied to the tray.

To circulate the fluid, close valves P and N.

To lower the fluid level in the tray, close valve P and open valve N.

To raise the fluid level in the tray, close valve N and open valve P.

This is a basic system. Additional equipment such as solenoids and float valves can be used for automated systems. See your Graco representative for details.

Fig. 1

03914

TWO FLUIDS TO TWO DESTINATIONS Uses dual inlet and dual outlet manifolds.

System Explanation

Supplies two fluids, such as two colors of ink, to two separate destinations. Use in installations where surging does not cause a problem.

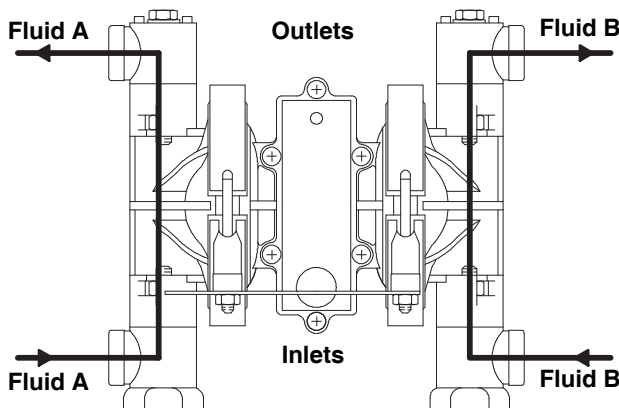

Fig. 2

03913

1:1 MIX RATIO (approximate) Uses dual inlet and single outlet manifolds.

System Explanation

Mixes two fluids, such as antifreeze and water, in an approximate 1:1 ratio. Minimum fluid output should be in increments of 3 quarts to ensure an approximate 1:1 ratio. Lower output quantities may result in an unequal mix ratio.

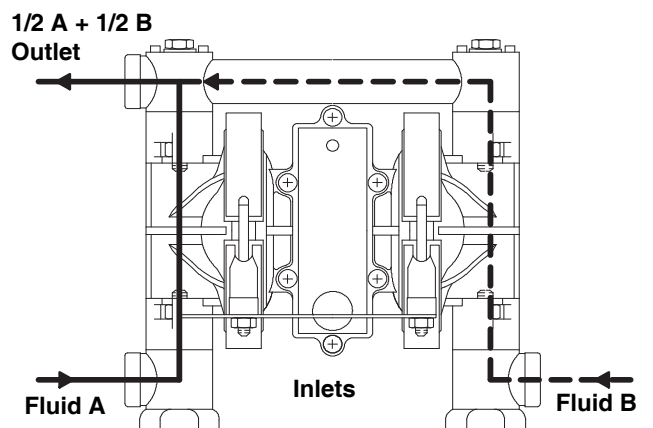

Fig. 3

03915

Installation

Installation Procedure

WARNING

Pressure Relief Procedure

To reduce the risk of serious injury, including splashing fluid or solvent in the eyes or on the skin, follow this procedure before installing this kit:

1. Shut off the air to the pump.
2. Open the dispensing valve, is used.
3. Open the fluid drain valve to relieve all fluid pressure, having a container ready to catch the drainage.

1. Follow the **Pressure Relief Procedure** above.
2. Disconnect the fluid inlet and/or outlet line from the pump manifolds.
3. Remove the fluid inlet and/or fluid outlet manifold, as explained in the pump manual 308553. Keep the attaching hardware (A, B) and the feet (D).
4. Remove the outer o-ring from each cover (C) and replace them with the new o-rings (3) from the kit. See Fig. 4.

NOTE: Acetal pumps use screws (A) and nuts (B) to secure the manifolds, as shown in FIG. 4. Polypropylene pumps use nuts, washers, and tie rods; refer to manual 308553.

5. Install the split manifolds (1). Apply thread lubricant to the screws and torque to 50-60 in-lb (5.6-6.8 N•m). Do not over-torque. See **Torque Sequence**, page 5.
6. The warning label (2) supplied in the kit replaces the one on the standard outlet manifold removed in step 3. First, clean the pump cover (C) with a compatible solvent so the label will adhere permanently, then install the label as shown.
7. Connect the fluid inlet and/or outlet lines to the manifolds securely, and return the pump to service.
8. Prolonged exposure to UV radiation will degrade natural polypropylene components of the pumps. To prevent potential injury or equipment damage, do not expose pump or the plastic components to direct sunlight for prolonged periods.

Installation

Installing a Split Outlet Manifold

Installing a Split Inlet Manifold

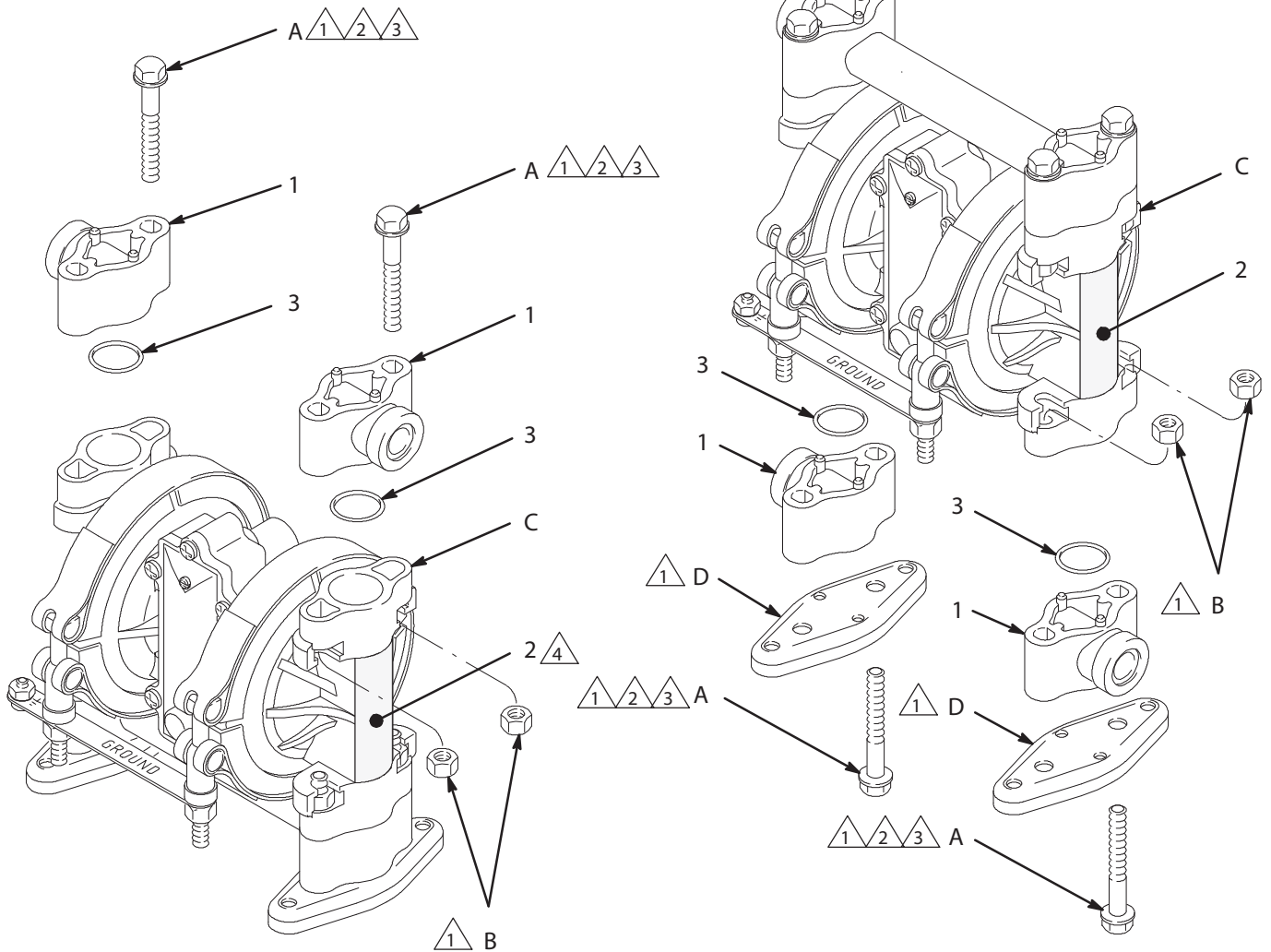

- ⚠ Part of pump; not supplied in kit.
- ⚠ Apply thread lubricant.
- ⚠ Torque to 50-60 in-lb (5.6-6.8 N•m). Do not over-torque.
- ⚠ See the **WARNING** below.

03912

Fig. 4

⚠ WARNING

The warning label (2) included in the kit contains important information for the safe operation of this pump. Clean the surface of the cover (C) with a compatible solvent and secure the label as shown.

Parts

Part No. 237210 Split Manifold Kit For Polypropylene Pumps

Ref. No.	Part No.	Description	Qty.
1	190151	MANIFOLD, split; polypropylene	2
2	187732	LABEL, warning	1
3	111603	O-RING; PTFE	2

Part No. 237211 Split Manifold Kit For Acetal Pumps

Ref. No.	Part No.	Description	Qty.
1	190152	MANIFOLD, split; acetal	2
2	187732	LABEL, warning	1
3	111603	O-RING; PTFE	2

Torque Sequence

Always follow torque sequence when instructed to torque fasteners.

1. Left/Right Fluid Covers
Torque bolts to 50-60 in-lbs (5.6-6.8 N•m)
2. Outlet Manifold to Fluid Cover
Torque bolts to 50-60 in-lbs (5.6-6.8 N•m)
3. Inlet Manifold to Fluid Cover
Torque bolts to 50-60 in-lbs (5.6-6.8 N•m)

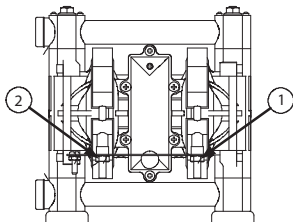

FRONT VIEW

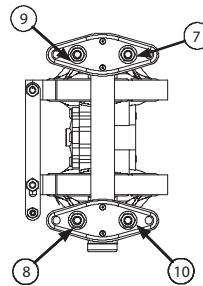

BOTTOM VIEW

2. Outlet Manifold to Fluid Cover
Torque bolts to 50-60 in-lbs (5.6-6.8 N•m)

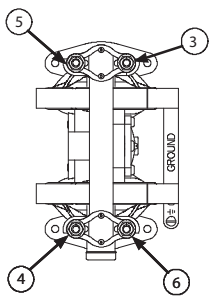

TOP VIEW

Graco Standard Husky Pump Warranty

Graco warrants all equipment referenced in this document which is manufactured by Graco and bearing its name to be free from defects in material and workmanship on the date of sale to the original purchaser for use. With the exception of any special, extended, or limited warranty published by Graco, Graco will, for a period of twelve months from the date of sale, repair or replace any part of the equipment determined by Graco to be defective. This warranty applies only when the equipment is installed, operated and maintained in accordance with Graco's written recommendations.

This warranty does not cover, and Graco shall not be liable for general wear and tear, or any malfunction, damage or wear caused by faulty installation, misapplication, abrasion, corrosion, inadequate or improper maintenance, negligence, accident, tampering, or substitution of non-Graco component parts. Nor shall Graco be liable for malfunction, damage or wear caused by the incompatibility of Graco equipment with structures, accessories, equipment or materials not supplied by Graco, or the improper design, manufacture, installation, operation or maintenance of structures, accessories, equipment or materials not supplied by Graco.

This warranty is conditioned upon the prepaid return of the equipment claimed to be defective to an authorized Graco distributor for verification of the claimed defect. If the claimed defect is verified, Graco will repair or replace free of charge any defective parts. The equipment will be returned to the original purchaser transportation prepaid. If inspection of the equipment does not disclose any defect in material or workmanship, repairs will be made at a reasonable charge, which charges may include the costs of parts, labor, and transportation.

THIS WARRANTY IS EXCLUSIVE, AND IS IN LIEU OF ANY OTHER WARRANTIES, EXPRESS OR IMPLIED, INCLUDING BUT NOT LIMITED TO WARRANTY OF MERCHANTABILITY OR WARRANTY OF FITNESS FOR A PARTICULAR PURPOSE.

Graco's sole obligation and buyer's sole remedy for any breach of warranty shall be as set forth above. The buyer agrees that no other remedy (including, but not limited to, incidental or consequential damages for lost profits, lost sales, injury to person or property, or any other incidental or consequential loss) shall be available. Any action for breach of warranty must be brought within two (2) years of the date of sale.

GRACO MAKES NO WARRANTY, AND DISCLAIMS ALL IMPLIED WARRANTIES OF MERCHANTABILITY AND FITNESS FOR A PARTICULAR PURPOSE IN CONNECTION WITH ACCESSORIES, EQUIPMENT, MATERIALS OR COMPONENTS SOLD BUT NOT MANUFACTURED BY GRACO.

These items sold, but not manufactured by Graco (such as electric motors, switches, hose, etc.), are subject to the warranty, if any, of their manufacturer. Graco will provide purchaser with reasonable assistance in making any claim for breach of these warranties.

In no event will Graco be liable for indirect, incidental, special or consequential damages resulting from Graco supplying equipment hereunder, or the furnishing, performance, or use of any products or other goods sold hereto, whether due to a breach of contract, breach of warranty, the negligence of Graco, or otherwise.

FOR GRACO CANADA CUSTOMERS

The parties acknowledge that they have required that the present document, as well as all documents, notices and legal proceedings entered into, given or instituted pursuant hereto or relating directly or indirectly hereto, be drawn up in English. Les parties reconnaissent avoir convenu que la rédaction du présente document sera en Anglais, ainsi que tous documents, avis et procédures judiciaires exécutés, donnés ou intentés à la suite de ou en rapport, directement ou indirectement, avec les procédures concernées.

Graco Information

For the latest information about Graco products, visit www.graco.com.

For patent information, visit www.graco.com/patents.

TO PLACE AN ORDER, contact your Graco distributor, or call this number to identify the distributor closest to you:

Phone: 612-623-6921 or **Toll Free:** 1-800-328-0211 **Fax:** 612-378-3505

All written and visual data contained in this document reflects the latest product information available at the time of publication. Graco reserves the right to make changes at any time without notice.

Original instructions. This manual contains English. MM 308439

Graco Headquarters: Minneapolis
International Offices: Belgium, China, Japan, Korea

GRACO INC. P.O. BOX 1441 MINNEAPOLIS, MN 55440-1441
Copyright 1994, Graco Inc. All Graco manufacturing locations are registered to ISO 9001.

www.graco.com
Revision E, August 2019