



This manual contains important warnings and information.
READ AND KEEP FOR REFERENCE.

INSTRUCTIONS

GM3000 Airless Paint Sprayer

3000 psi (210 bar, 21 MPa) Maximum Working Pressure

Model 231363, Series B

Basic Sprayer with Upright Cart

Model 231551

Same as 231363, with hose and gun, RAC® X HandTite™ Tip Guard, and 517 size SwitchTip™

Model 231550, Series B

Basic Sprayer with Lo-Boy Cart

Model 231552

Same as 231550, with hose and gun, RAC® X HandTite™ Tip Guard, and 517 size SwitchTip™

⚠ CAUTION

Always use a minimum hose length of 50 foot (15 m) 1/4 inch ID or 50 foot (15 m) 3/8 inch ID. An undersized hose may result in poor equipment performance and damage to the clutch.

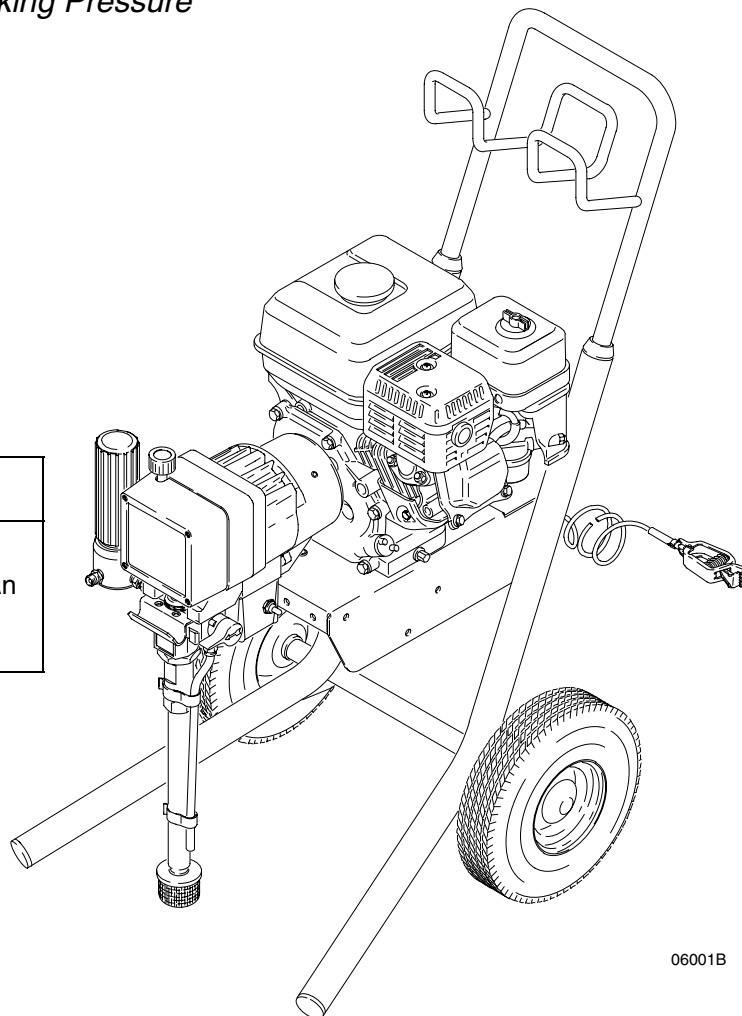

06001B



Model 231363 Shown

Table of Contents

Warnings	2	Clutch Housing	27
Component Identification and Function	5	Reassembly	28
Setup	6	Displacement Pump Repair	31
Fueling	8	Pressure Control Parts list	33
Startup	9	Upright Sprayer Parts Drawing	34
Maintenance	11	Upright Sprayer Parts List	35
Flushing	12	Lo-Boy Sprayer Parts Drawing	36
Troubleshooting	14	Lo-Boy Sprayer Parts List	37
Drive Housing, Connecting Rod, Crankshaft	16	Parts List & Drawing – Complete Sprayers	38
Pressure Control	18	Pinion Assembly Parts list and Drawing	38
Pinion, Clutch, Clamp, Field, & Engine	23	Accessories	39
Pinion Housing	24	Technical Data	39
Clutch	25	Dimensions	39
Engine	26	Graco Phone Number	39
Field & Wiring Harness	27	Graco Warranty	40
Clamp	27		

Symbols

Warning Symbol



This symbol alerts you to the possibility of serious injury or death if you do not follow the instructions.

Caution Symbol



This symbol alerts you to the possibility of damage to equipment if you do not follow the instructions.

! WARNING



INSTRUCTIONS

EQUIPMENT MISUSE HAZARD

Equipment misuse can cause the equipment to rupture or malfunction and result in serious injury.

- This equipment is for professional use only.
- Read all instruction manuals, tags, and labels before operating the equipment.
- Use the equipment only for its intended purpose. If you are not sure, call your distributor.
- Do not alter or modify this equipment. Use only genuine Graco parts.
- Check equipment daily. Repair or replace worn or damaged parts immediately.
- Do not exceed the maximum working pressure of the lowest rated system component. Refer to the **Technical Data** on page 39 for the maximum working pressure of this equipment.
- Use fluids and solvents which are compatible with the equipment wetted parts. Refer to the **Technical Data** section of all equipment manuals. Read the fluid and solvent manufacturer's warnings.
- Do not use hoses to pull equipment.
- Route hoses away from traffic areas, sharp edges, moving parts, and hot surfaces. Do not expose Graco hoses to temperatures above 82°C (180°F) or below -40°C (-40°F).
- Do not lift pressurized equipment.
- Comply with all applicable local, state, and national fire, electrical, and safety regulations.
- Wear hearing protection when operating this equipment.
- Do not use 1,1,1-trichloroethane, methylene chloride, other halogenated hydrocarbon solvents or fluids containing such solvents in pressurized aluminum equipment. Such use could result in a chemical reaction, with the possibility of explosion.

WARNING



INJECTION HAZARD

Spray from the gun, leaks or ruptured components can inject fluid into your body and cause extremely serious injury, including the need for amputation. Fluid splashed in the eyes or on the skin can also cause serious injury.

- Fluid injected into the skin may look like just a cut, but it is a serious injury. **Get immediate medical attention.**
- Do not point the gun at anyone or at any part of the body.
- Do not put your hand or fingers over the spray tip.
- Do not stop or deflect leaks with your hand, body, glove or rag.
- Do not “blow back” fluid; this is not an air spray system.
- Always have the tip guard and the trigger guard on the gun when spraying.
- Check the gun diffuser operation weekly. Refer to the gun manual.
- Be sure the gun trigger safety operates before spraying.
- Lock the gun trigger safety when you stop spraying.
- Follow the **Pressure Relief Procedure** on page 12 if the spray tip clogs and before cleaning, checking or servicing the equipment.
- Tighten all fluid connections before operating the equipment.
- Check the hoses, tubes, and couplings daily. Replace worn or damaged parts immediately. Do not repair high pressure couplings; you must replace the entire hose.
- Fluid hoses must have spring guards on both ends, to help protect them from rupture caused by kinks or bends near the couplings.



TOXIC FLUID HAZARD

Hazardous fluid or toxic fumes can cause serious injury or death if splashed in the eyes or on the skin, inhaled, or swallowed.

- Know the specific hazards of the fluid you are using.
- Store hazardous fluid in an approved container. Dispose of hazardous fluid according to all local, state and national guidelines.
- Always wear protective eyewear, gloves, clothing and respirator as recommended by the fluid and solvent manufacturer.



FUEL HAZARD

The fuel used in this unit is combustible and when spilled on a hot surface can ignite and cause a fire.

- Do not fill the fuel tank while the engine is running or hot.



EXHAUST HAZARD

The exhaust contains poisonous carbon dioxide which is colorless and odorless.

- Do not operate this equipment in a closed building.

⚠ WARNING



FIRE AND EXPLOSION HAZARD

Improper grounding, poor ventilation, open flames or sparks can cause a hazardous condition and result in a fire or explosion and serious injury.



- If there is any static sparking or you feel an electric shock while using this equipment, **stop spraying immediately**. Do not use the equipment until you identify and correct the problem.
- Provide fresh air ventilation to avoid the buildup of flammable fumes from solvents or the fluid being sprayed.
- Keep the spray area free of debris, including solvent, rags, and gasoline.
- Disconnect all electrical equipment in the spray area.
- Extinguish all open flames or pilot lights in the spray area.
- Do not smoke in the spray area.
- Do not turn on or off any light switch in the spray area while operating or if fumes are present.
- Do not operate a gasoline engine in the spray area.
- Ground the sprayer to a true earth ground with the ground wire and clamp (supplied).
- Use only electrically conductive hoses.



MOVING PARTS HAZARD

Moving parts can pinch or amputate your fingers.

- Keep clear of all moving parts when starting or operating the sprayer.
- Before servicing the equipment, follow the **Pressure Relief Procedure** on page 12 to prevent the equipment from starting unexpectedly.

NOTE: This is an example of the DANGER label on your sprayer. This label is available in other languages, free of charge. See page 39 to order.

⚠ DANGER ⚠			
	FIRE AND EXPLOSION HAZARD		SKIN INJECTION HAZARD
<p>Spray painting, flushing or cleaning equipment with flammable liquids in confined areas can result in fire or explosion.</p> <p>Use outdoors or in extremely well ventilated areas. Ground equipment, hoses, containers and objects being sprayed.</p> <p>Avoid all ignition sources such as static electricity from plastic drop cloths, open flames such as pilot lights, hot objects such as cigarettes, arcs from connecting or disconnecting power cords or turning light switches on and off.</p> <p>Failure to follow this warning can result in death or serious injury.</p>		<p>Liquids can be injected into the body by high pressure airless spray or leaks – especially hose leaks.</p> <p>Keep body clear of the nozzle. Never stop leaks with any part of the body. Drain all pressure before removing parts. Avoid accidental triggering of gun by always setting safety latch when not spraying.</p> <p>Never spray without a tip guard.</p> <p>In case of accidental skin injection, seek immediate “Surgical Treatment”.</p> <p>Failure to follow this warning can result in amputation or serious injury.</p>	
READ AND UNDERSTAND ALL LABELS AND INSTRUCTION MANUALS BEFORE USE			

Component Identification and Function

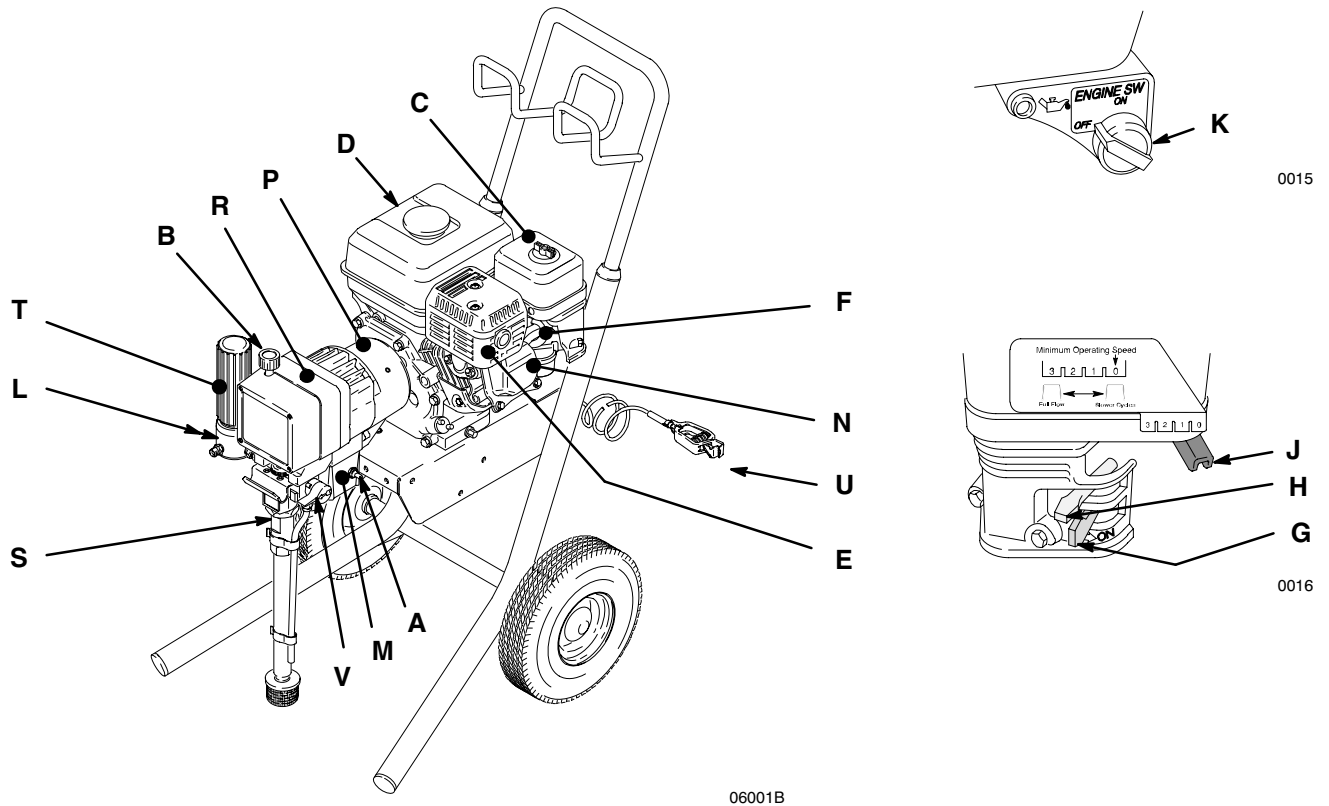

Fig. 1

A	Pressure Control Switch	ON/OFF, enables/disables clutch function
B	Pressure Adjusting Knob	Controls fluid outlet pressure
C	Air Cleaner*	Filters air entering the carburetor
D	Fuel Tank*	Holds 0.66 gallons (2.5 liters) of [(R+M)/2]; 86 octane gasoline
E	Muffler*	Reduces noise of internal combustion
F	Spark Plug Cable*	Routes electrical current to spark plug
G	Fuel Valve*	On/off valve to regulate fuel flow from gasoline tank to carburetor
H	Choke*	Enriches air/gasoline mixture for cold starting
J	Throttle*	Adjusts engine speed for large or small orifice spray tips
K	Engine Switch*	Enables/disables engine operation
L	Fluid Outlet	Hose and spray gun are connected here
M	Pressure Control	Controls clutch cycling to maintain fluid pressure.
N	Engine*	4.0 HP gasoline engine
P	Clutch	Transfers power from engine to drive assembly
R	Drive Assembly	Transfers power from clutch to displacement pump
S	Displacement Pump	Provides fluid to be sprayed through spray gun
T	Fluid Filter	Filters fluid between source and spray gun
U	Grounding Clamp and Wire	Grounds sprayer system
V	Pressure Drain Valve	Relieves fluid pressure when open
*	For more detailed explanations of these controls, refer to the Honda engine manual; supplied	

Setup

⚠ CAUTION

To avoid damaging the pressure control, which may result in poor equipment performance and component damage, follow these precautions.

1. Always use nylon spray hose. Never use a wire braid hose; it is too rigid to act as a pulsation dampener.
2. Always use a minimum hose length of 50 foot (15 m) x 1/4 inch ID or 50 foot (15 m) x 3/8 inch ID hose.
3. Never install any shutoff device between the filter (21) and the main hose. See Fig. 2.
4. Always use the main filter outlet (20) for a one gun operation. Never plug this outlet.

1. **Connect hose and gun.** (Refer to Fig. 2.)
 - a. Remove the plastic cap from the 1/4 npsm (m) filter outlet nipple (20). Screw the main fluid hose onto the nipple. Read the CAUTION, above.
 - b. Connect the whip end hose between the main fluid hose and the inlet adapter of the gun.
 - c. Do not use thread sealant, and do not install the spray tip yet!

⚠ WARNING

If you supply your own hoses and spray gun, be sure the hoses are electrically conductive, that the gun has a tip guard, and that each part is rated for at least *3000 psi (210 bar, 21 MPa) Maximum Working Pressure*. This is to reduce the risk of serious injury caused by static sparking, fluid injection or over-pressurization and rupture of the hose or gun.

2. **Fill packing nut/wetcup.** Fill the packing nut/wetcup (A) 1/3 full with Graco Throat Seal Liquid (TSL), supplied. See Fig. 2.
3. **Check the engine oil level.** Refer to the Honda engine manual, supplied. This is a summary of the information: Remove one of the oil fill plugs (M); the oil should be almost overflowing. See Fig. 3. Add oil as necessary.

Recommended lubrication oil: Use a high-quality, detergent oil, SAE 10W-30, classified "FOR SERVICE SG or SF", for regular use and for breaking-in a new engine.

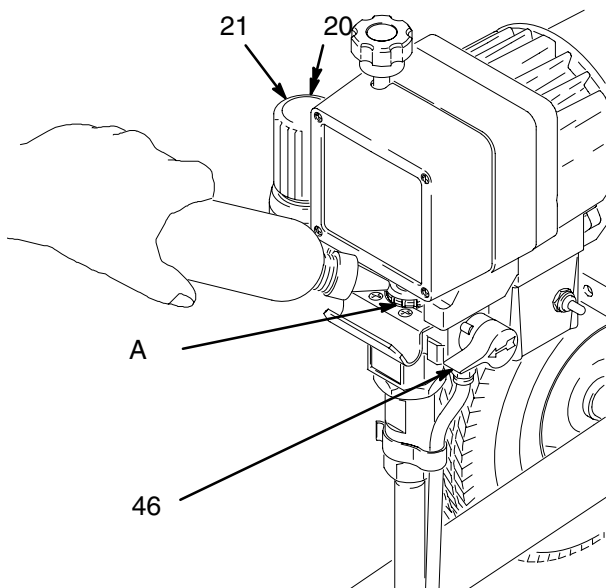

- 21 Fluid Filter
- 46 Pressure drain valve
- 20 1/4 npsm(m) fluid outlet
- A Wetcup

05832

Fig. 2

Setup

4. **Be sure your system is properly grounded before operating it.** Connect the sprayer to a true earth ground with the grounding wire and clamp (80) ; for example, a cold water pipe or a ground rod driven into the earth.
5. **Fill the gas tank.** See **Fueling**, page 8.
6. **Flush the pump** to remove the lightweight oil which was left in the pump to protect it from corrosion.
 - a. Before using water–base paint, flush with mineral spirits, followed by soapy water, and then flush with clean water.
 - b. Before using oil–base paint, flush with mineral spirits, only.
 - c. See **Flushing** on page 13 for the flushing procedure.
7. **Prepare the paint** according to the manufacturer's recommendations.
 - a. Remove any skin that may have formed.
 - b. Stir the paint to mix the pigments.
 - c. Strain the paint through a fine nylon mesh bag (available at most paint dealers) to remove the particles that could clog the filter or spray tip. This is probably the most important step toward trouble–free spraying.
8. **Keep the sprayer upright and level** during operation and whenever it is being moved. See the **CAUTION** on page 10.

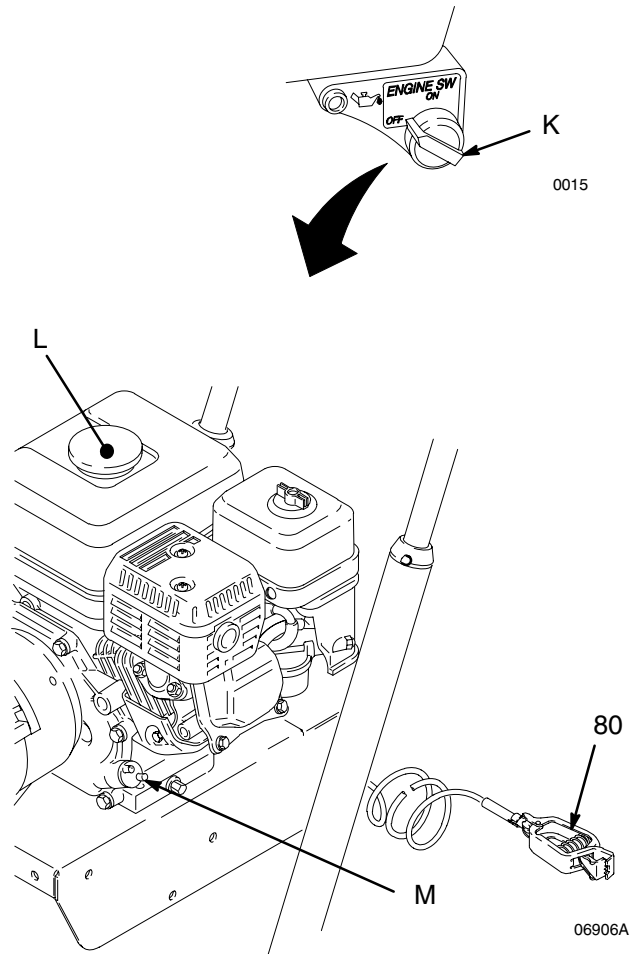

Fig. 3

Fueling

WARNING



FIRE AND EXPLOSION HAZARD

Gasoline is extremely flammable and explosive under certain conditions.



Always turn the engine switch (K) to off before refueling. (Fig. 3)

Refuel in a well-ventilated area.

Do not smoke or allow flames or sparks in the area where the engine is refueled or where the gasoline is stored.

Do not overfill the tank. Make sure the gas fill cap (L) is securely closed after refueling. (Fig. 3)

Be careful not to spill fuel when fueling. Fuel vapor or spilled fuel can ignite. If any fuel is spilled, make sure the area is dry before starting the engine.

1. **Fuel specifications.** Use automotive gasoline with a pump octane number of 86 or higher, or a research octane number of 91 or higher. Unleaded fuel minimizes the combustion chamber deposits.

2. **Gasolines containing alcohol (gasohol).** Do not use gasohol which contains methanol, if the gasohol does not contain cosolvents and corrosion inhibitors for methanol. Even if it does contain such additives, do not use the gasohol if it contains more than 5% methanol or 10 % ethanol.

NOTE: The Honda engine warranty does not cover the damage resulting from the use of gasolines containing a higher percentage of alcohol than mentioned in step 2. See the Honda engine manual for more information.

3. **General.** Do not use any oil and gasoline mixtures or contaminated gasoline. Avoid getting any dirt, dust or water in the fuel tank.
4. **Tank Capacity.** 0.66 gallons (2.5 liters). Always leave at least 1/2 in. (13 mm) at the top of the tank for expansion.
5. **Shut off the engine before refueling.**
6. **After refueling, tighten the fuel tank cap firmly.**

Startup

Before You Start the Sprayer

1. **See Flushing** on page 12 to determine if you should flush the sprayer.
2. **Be sure the gas tank is full.**
3. **Check the engine oil level.**

NOTE: The engine stops automatically, or will not start, if it is low on oil. Refer to the oil fill procedure in the Honda engine manual or to step 3, page 6.

4. **Be sure the spark plug cable is firmly pushed onto the plug.**

Starting the Sprayer

NOTE: Refer to Fig. 1 as you start the sprayer.

1. **When starting a sprayer that IS NOT PRIMED,** remove the spray tip.
2. **Place the suction tube into the paint, water or solvent container,** depending on whether you are flushing or are ready to spray.
3. **Open the black fuel shutoff lever** by pushing it in the direction of the arrow.

CAUTION

Never try to start the engine unless fluid pressure is relieved and the pressure control switch is OFF. Trying to start the engine when it is pressurized could damage the recoil system.

4. **Move the pressure control switch to OFF.**
5. **To start the engine:**
 - a. Turn the pressure adjusting knob all the way counterclockwise to the lowest pressure setting.
 - b. Slide the metal throttle lever away from the fuel tank to maximum position (fully left).
 - c. If the engine is cold, close the choke by moving the gray lever.
 - d. If the engine is warm, close the choke by moving the gray lever only half way or not at all.
 - e. Turn the engine switch to ON.

WARNING



MOVING PARTS HAZARD

A rope which recoils too quickly may hit someone and cause serious injury. The rope could also jam in recoil assembly.

- f. Hold the frame of the sprayer with one hand and pull the starter rope rapidly and firmly. Continue holding the rope as you let it return. Pull and return the rope until the engine starts.
 - g. Open the choke as soon as the engine starts, except in cold weather. In cold weather, leave the choke closed for 10 to 30 seconds before opening it to keep the engine running.
6. **Unlock the gun trigger safety.**

Startup

7. Prime the pump:

- a. Place the suction tube in the bucket of paint, water, or solvent.
- b. Open the pressure drain valve.
- c. Set engine speed to idle.
- d. Move the pressure control switch to ON. Turn the pressure adjusting knob slowly until the sprayer starts.
- e. Run the pump until fluid is flowing smoothly from the pressure drain valve, indicating the pump is primed.
- f. Move the pressure control switch to OFF.
- g. If the pump was primed with water or solvent, remove the suction tube from the water or solvent and place it in the paint. Repeat steps b through f.
- h. Close the pressure drain valve.

8. When the pump is primed:

- a. Remove the spray tip.
- b. Set the engine speed to full flow.
- c. Move the pressure control switch to ON. Turn the pressure adjusting knob slowly until the sprayer starts.
- d. Unlock the gun trigger safety.
- e. Trigger the gun into the pail until fluid flows from the gun. If pumping solvent or solvent-based paint, hold a metal part of the gun firmly against a grounded metal pail.
- f. Release the gun trigger and lock the gun trigger safety.
- g. Move the pressure control switch to OFF.

- h. Relieve pressure by opening the pressure drain valve.
- i. Close the pressure drain valve.

WARNING

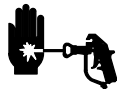

INJECTION HAZARD

To reduce the risk of serious injury from fluid injection, never operate the spray gun with the tip guard removed.

9. **Install the spray tip in the gun.** See the separate tip instruction manual, 308-644, supplied.
10. Move the pressure control switch to ON.
11. **Adjust the engine speed and pump pressure.** Unlock the gun trigger safety. Trigger the gun onto a test paper to check the spray pattern and atomization. Turn the pressure adjusting knob until you get a good pattern. Then slowly lower the throttle setting as far as you can without changing the spray pattern.

CAUTION

Always use the lowest needed fluid pressure and the lowest needed throttle setting, to increase the life of the sprayer. Higher settings cause excessive clutch cycling, premature tip wear and premature pump wear.

CAUTION

Close the black fuel shutoff lever whenever you are transporting the sprayer to prevent fuel from flooding the engine.

Keep the sprayer upright and level when operating it and when transporting it. This prevents crankcase oil from leaking into the combustion chamber, which makes startup very difficult.

Startup

⚠ CAUTION

Operating the sprayer with the pump not primed can lead to premature packing wear and/or damage to the pump.

Loss of Prime to Pump

Introduction of air into the pump, either by changing fluids or due to a suction leak, may result in the loss of prime to the pump. If the pump loses prime, no fluid is pumped.

To prime the pump, relieve the pressure on the system by opening the drain valve and following the instruction on **Prime the pump**, page 10.

Maintenance

⚠ WARNING



INJECTION HAZARD

To reduce the risk of serious injury, whenever you are instructed to relieve pressure, follow the **Pressure Relief Procedure** on page 12.

Procedure on page 12.

DAILY: Check the engine oil level and fill as necessary.

DAILY: Check and fill the gas tank.

AFTER THE FIRST 20 HOURS OF OPERATION

Drain the oil and refill with clean oil.

WEEKLY: Remove the cover of the air filter and clean the element. Replace the element, if necessary. If operating in an unusually dusty environment, check the filter daily and replace it, if necessary.

Replacement elements may be purchased from your local Honda dealer.

⚠ CAUTION

For detailed engine maintenance and specifications, refer to the separate engine manual, supplied.

WEEKLY: Check the level of the TSL in the displacement pump packing nut. Fill the nut, if necessary. Keep TSL in the nut to help prevent fluid buildup on the piston rod and premature wear of the packings.

Monthly: Remove the front cover (9) and fill the cavity in the connecting rod with non-detergent motor oil 1/4 in. below the surface. See Fig. 4.

AFTER EACH 100 HOURS OF OPERATION: Change the oil. Refer to the engine manual for additional maintenance instructions.

SPARK PLUG: Use only an (NGK) BPR6ES or a (NIPPON DENSO) W20EPR-U plug. Gap the plug to 0.028 to 0.031 inch (0.7 to 0.8 mm). Use a spark plug wrench when installing and removing the plug.

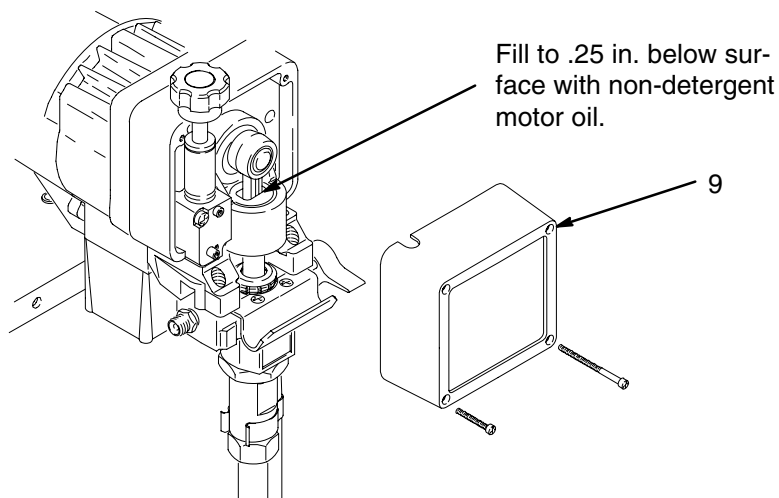

Fig. 4

06011

Pressure Relief Procedure

WARNING



INJECTION HAZARD

The system pressure must be manually relieved to prevent the system from starting or spraying accidentally. Fluid under high pressure can be injected through the skin and cause serious injury. To reduce the risk of an injury from injection, splashing fluid, or moving parts, follow the **Pressure Relief Procedure** whenever you:

- are instructed to relieve the pressure,
- stop spraying,
- check or service any of the system equipment,
- install or clean the spray tip.

1. Engage the gun safety latch.
2. Turn the engine switch to OFF.
3. Move the pressure control ON/OFF switch to OFF.
4. Disengage the gun safety latch. Hold a metal part of the gun firmly to a grounded metal pail. Trigger the gun to relieve pressure.
5. Engage the gun safety latch.
6. Open the pressure drain valve. Leave the pressure drain valve open until you are ready to spray again.
7. Disconnect the spark plug cable.

If you suspect that the spray tip or hose is completely clogged, or that pressure has not been fully relieved after following the steps above, **VERY SLOWLY** loosen the tip guard retaining nut or hose end coupling to Relieve the pressure gradually, then loosen completely. Now clear the tip or hose.

Flushing

When to Flush

1. New Sprayer. This sprayer was factory tested in lightweight oil, which was left in to protect the pump parts.

Before using water-base paint, flush with mineral spirits, followed by a soapy water flush, and then a clean water flush.

Before using oil-base paint, flush with mineral spirits.

2. Changing Colors. Flush with a compatible solvent such as mineral spirits or water.
3. Changing from water-base to oil-base paint. Flush with warm, soapy water, then mineral spirits.
4. Changing from oil-base to water-base paint. Flush with mineral spirits, followed by warm, soapy water, and then a clean water flush.

5. Storage.

Water base paint: flush with water, then mineral spirits and leave the pump, hose and gun filled with mineral spirits. Shut off the sprayer, remove the spark plug cable, and open the pressure drain valve to Relieve the pressure. Leave the drain valve open.

Oil base paint: flush with mineral spirits and leave the pump, hose and gun filled with mineral spirits. Shut off the sprayer, remove the spark plug cable, and open the pressure drain valve to Relieve the pressure. Leave the drain valve open.

6. Startup after storage.

Before using water-base paint, flush out the mineral spirits with soapy water, and then with clean water.

When using oil-based paint, flush out the mineral spirits with the paint to be sprayed.

CAUTION

To prevent pump corrosion or damage to pump components, never leave water or any type of paint in the sprayer when it is not in use. Pump the water or the paint out with mineral spirits.

Flushing

How to Flush

CAUTION

When changing fluids, do not drain all of the first fluid from the suction tube before inserting the suction tube into the another fluid. Not doing so may introduce excessive air into the pump and cause the pump to lose prime.

After moving the suction tube to a new fluid, pump the first fluid and any trapped air, out through the drain valve before beginning to pump the new fluid to the guns.

NOTE: The word solvent refers to water or oil-based solvent.

1. Follow the **Pressure Relief Procedure**, page 12.
2. Remove the filter bowl and screen; see instruction manual 308249, supplied. Install the bowl and support, without the screen, to flush. Clean the screen separately.
3. Close the pressure drain valve.
4. Put the suction tube in a grounded pail of solvent.
5. Remove the spray tip from the gun.

WARNING



FIRE AND EXPLOSION HAZARD

To reduce static sparking and splashing, always remove the spray tip from the gun, and hold a metal part of the gun firmly to the side of a grounded metal pail when flushing.

6. Follow **Startup** on page 9. Keep the gun triggered until clean solvent comes from the nozzle. Release the trigger and lock the gun trigger safety.

CAUTION

Operation with the pump not primed can lead to premature packing wear and damage to the pump.

7. Check all fluid connections for leaks. Relieve the pressure before tightening any connections. Start the sprayer. Recheck the connections for leaks.
8. Remove the suction tube from the solvent pail. Unlock the gun trigger safety. Trigger the gun to force solvent from the hose. Do not let the pump run dry for more than 30 seconds, to avoid damaging the pump packings. Relieve the pressure.
9. Unscrew the filter bowl and reinstall the clean screen. Reinstall the bowl, hand tight only.
10. Follow **Storage or Changing Colors**, on page 12. Relieve the pressure.

Troubleshooting

⚠ WARNING



INJECTION HAZARD

To reduce the risk of serious injury, whenever you are instructed to relieve pressure, follow the **Pressure Relief Procedure** on page 12.

Check everything in the chart before disassembling the sprayer. See pages 34 through 33 for description of referenced parts

PROBLEM	CAUSE	SOLUTION
The engine or sprayer won't start.	The engine switch is not on.	Turn on the switch.
	The engine is out of gas.	Refill the gas tank. See page 8.
	The engine oil level is low.	Try to start the engine. Replenish the oil, if necessary. See Step 3, page 6.
	The spark plug cable is disconnected or it is damaged	Reconnect the spark plug cable or replace the spark plug.
	There is frozen water in the sprayer.	Allow the sprayer to thaw completely before starting it.
The engine won't "pull over".	Oil is seeping into the combustion chamber.	Remove the spark plug. Pull the starter rope 3 or 4 times. Clean or replace the plug. Try to start the engine. Keep the sprayer upright to avoid oil seepage.
The engine operates, but the displacement pump does not operate.	The pressure control switch is turned off.	Turn on the switch.
	The pressure setting is too low.	Turn the pressure adjusting knob clockwise to increase pressure.
	The fluid filter (21) is dirty.	Clean the filter. See page 13.
	The tip or the tip filter is clogged.	Clean the tip or the tip filter. See the gun instruction manual.
	The displacement pump rod is stuck due to dried paint.	Repair the pump. See page 31.
	The connecting rod is worn or damaged.	Replace the connecting rod. See page 16.
	The drive housing is worn or damaged.	Replace the drive housing. See page 16.
	The electrical power is not energizing the field.	Check the wiring connections. See page 26. With the pressure control switch turned on and the pressure turned to maximum, use a test light to check the power at the black and white wires from the pressure control. Have the pressure control checked by an authorized Graco dealer.
	The clutch is worn, damaged, or incorrectly positioned.	Replace the clutch. See page 25.
The pinion assembly is worn or damaged.	Repair or replace the pinion assembly. See page 23.	

PROBLEM	CAUSE	SOLUTION
The pump output is low on the upstroke.	The inlet screen (102) is clogged.	Clean the screen.
	A piston ball (121) is not seating.	Service the piston ball—check. See page 31.
	The piston packings are worn or damaged.	Replace the packings. See page 31.
	A o-ring (119) in the displacement pump is worn or damaged.	Replace the o-ring. See page 31.
The output of the pump is low on the downstroke or on both of the strokes.	The inlet screen (39) is clogged.	Clean the screen.
	The piston packings are worn or damaged.	Replace the packings. See page 31.
	An intake valve ball is not seating properly.	Clean the intake valve. See page 31.
	The engine speed is too low.	Increase the throttle setting. See Step 11, page 10.
	The clutch is worn or damaged.	Replace the clutch. See page 25.
The paint leaks into the wetcup.	The wetcup is loose.	Tighten the wetcup just enough to stop leakage.
	The throat packings is worn or damaged.	Replace the packings. See page 31.
	A displacement rod is worn or damaged.	Replace the rod. See page 31.
The fluid delivery is low.	The inlet screen (39) is clogged.	Clean the screen.
	The pressure setting is too low.	Increase the pressure. See Step 11, page 10.
	The engine speed is too low.	Increase the throttle setting. See Step 11, page 10.
	The fluid filter (21), the tip filter or the tip is clogged or dirty.	Clean the filter. See page 13. Or, see the gun instruction manual.
	There is a large pressure drop in the hose.	Use a larger diameter hose.
Fluid is spitting from the gun.	There is air in the pump or the hose.	Check and tighten all the fluid connections. Reprime the pump. See page 10.
	The tip is partially clogged.	Clear the tip. See the gun instruction manual.
	The fluid supply is low or empty.	Refill the fluid supply. Prime the pump. See page 9. Check the fluid supply often to prevent running the pump dry.
The pump is difficult to prime.	There is air in the pump or the hose.	Check and tighten all the fluid connections. Reduce the engine speed and cycle the pump as slowly as possible during priming.
	The intake valve is leaking.	Clean the intake valve. Be sure ball seat is not nicked or worn and that the ball seats well. Reassemble the valve.
	The pump packings are worn.	Replace the pump packings. See page 31.
	The paint is too thick.	Thin the paint according to the supplier's recommendations.
	The engine speed is too high.	Decrease the throttle setting before priming the pump. See Step 7, page 10.

Drive Housing, Connecting Rod, Crankshaft

WARNING



INJECTION HAZARD

To reduce the risk of serious injury, whenever you are instructed to relieve pressure, follow the **Pressure Relief Procedure** on page 12.

Removal

NOTE: Inspect parts as they are removed. Replace parts that are worn or damaged.

1. Remove the displacement pump. See page 31.
2. Remove the pressure control (25). See page 18.
3. Remove the three drive housing screws and lock washers (15, 16). See Fig. 5 on page 17.
4. Remove the two pinion housing screws (69) and lock washers (16). See Fig. 5 on page 17.
5. Tap the lower rear of the drive housing (6) with a plastic mallet to loosen the drive housing. Pull the drive housing straight off the pinion housing.

CAUTION

Do not allow the gear (19) to fall; it may stay attached to the drive housing or to the pinion housing.

Do not lose the thrust balls (6a and 2d) or let them fall between the gears, which will damage the drive housing if not removed. The balls, which are heavily covered with grease, usually stay in the housing recesses, but could be dislodged. If the balls are not in place, the bearings will wear prematurely.

6. Remove and inspect the crankshaft (8) and the connecting rod (10).

Installation

7. Lubricate the inside of the drive housing bronze bearing with SAE non-detergent oil.
8. Install the connecting rod.
9. Place the large washer (5) and then the small washer (3) on the crankshaft (8).
10. Insert the crankshaft into the bearing in the drive housing (6) and connecting rod (10).
11. If replacing the complete drive housing assembly (6), brush G-n lubricant (supplied) on all gear teeth. Then recoat the gear teeth with bearing grease (supplied). Pack the remaining bearing grease into the bottom part of the drive housing. Use 0.22 pint of the grease. See Fig. 6.
12. Install gear (19).
13. Install new gasket (64).
14. Work backwards from step 4 to reassemble.

Drive Housing, Connecting Rod, Crankshaft

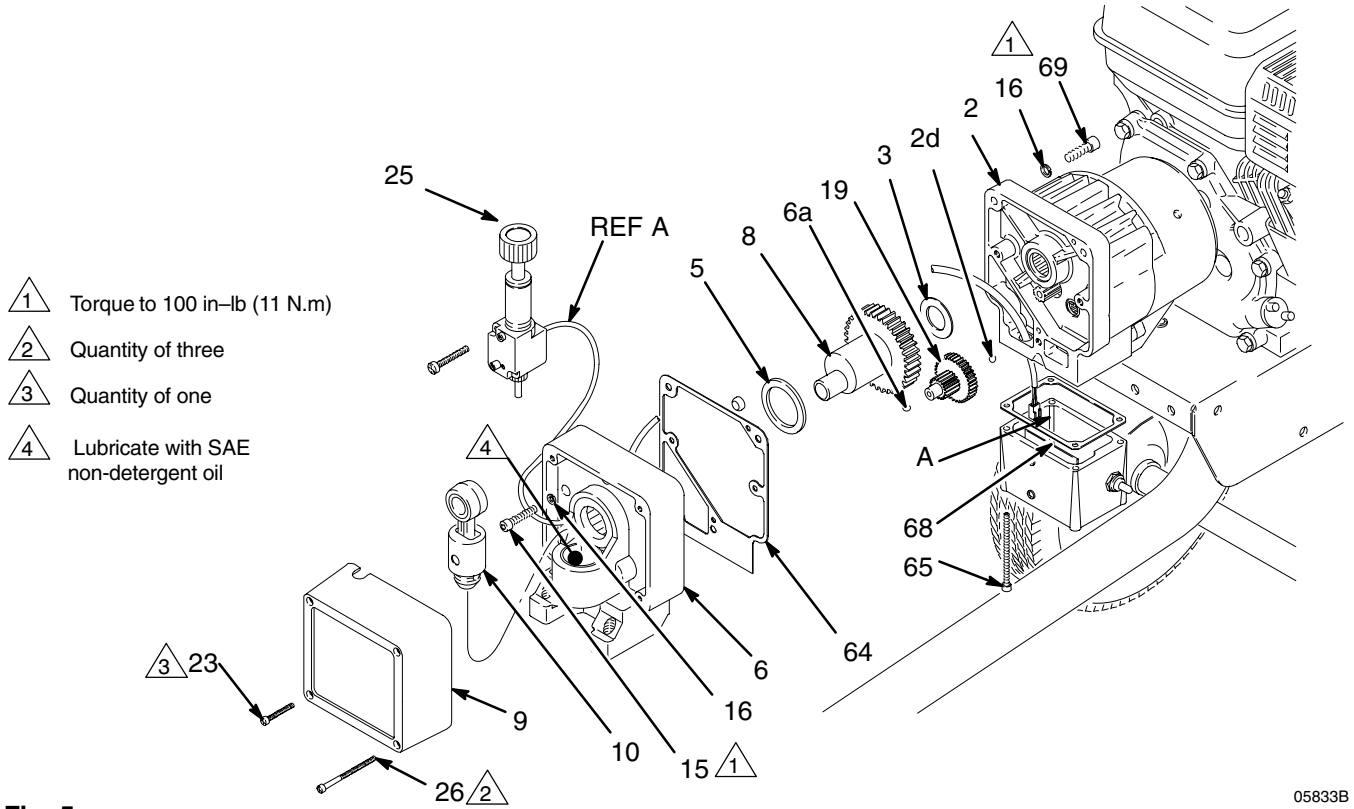

Fig. 5

05833B

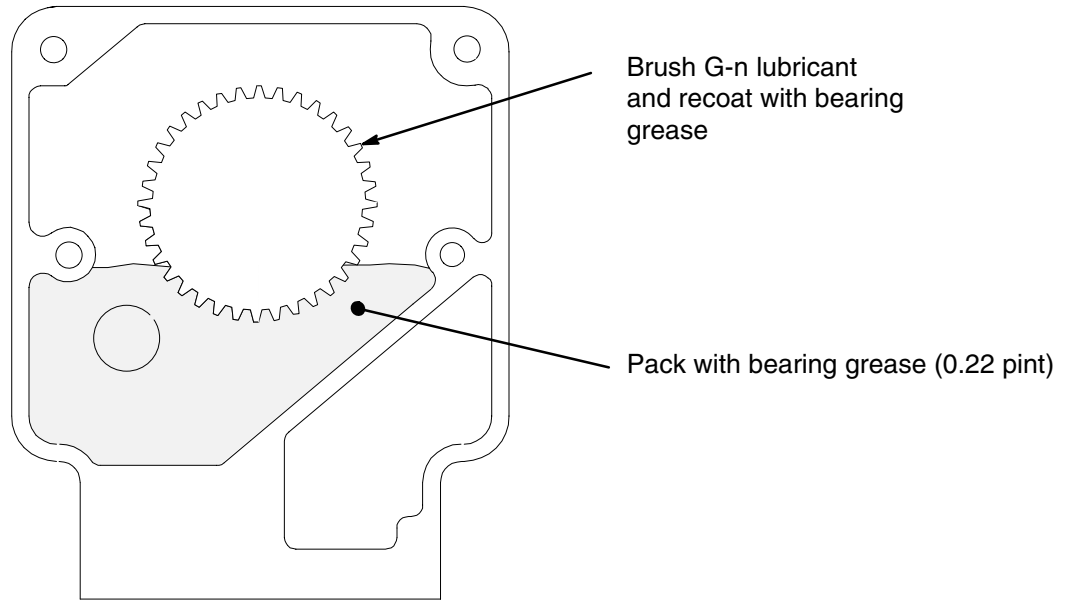

Fig. 6

06003

Pressure Control

⚠ WARNING



INJECTION HAZARD

To reduce the risk of serious injury, whenever you are instructed to relieve pressure, follow the **Pressure Relief Procedure** on page 12.

NOTE: See Fig. 7 for this procedure.

NOTE: The pressure control (25) cannot be repaired or adjusted. If it has malfunctioned, replace it.

1. Remove the front cover (9). Remove the screws (65) and lock washers (37). Lower the junction box (63).
2. Disconnect the harness connector (A) from the control module inside the box (63).
3. Remove the screws (24). Pull forward on the pressure adjusting knob and tip the pressure control (25) forward and up to detach it from the drive housing (6).
4. Guide the harness (A) through the pinion housing and drive housing and remove the pressure control.
5. Guide the harness of the new pressure control through the drive housing and pinion housing passages.
6. Install the new pressure control. Tip the pressure control down and back into the drive housing (6). Do not pinch or damage the harness (A).

7. Loosely install the screws (24) and then torque them to 21 in-lb (2.4 N.m).
8. Install the front cover (9). Connect the harness (A) to the control module leads (B).
9. Install the junction box. Be sure no leads are pinched against the mounting face of the pinion housing.

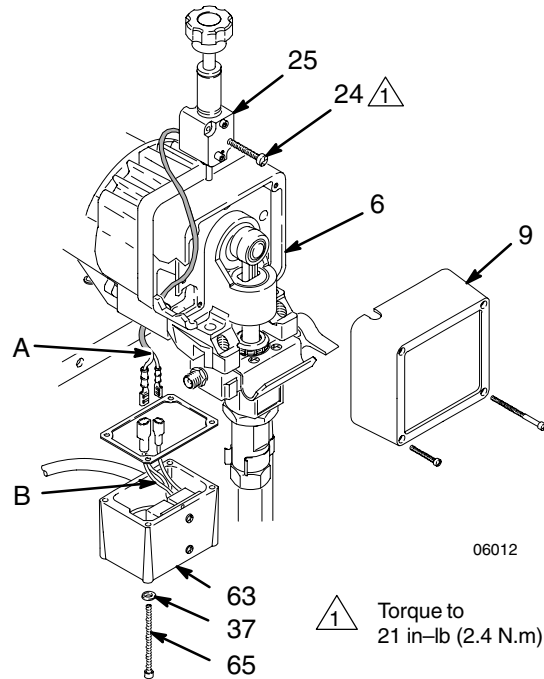

Fig. 7

Control Module

⚠ WARNING

INJECTION HAZARD
To reduce the risk of serious injury, whenever you are instructed to relieve pressure, follow the **Pressure Relief Procedure** on page 12.

NOTE: See Fig. 8 for this procedure.

1. Relieve pressure.
2. Remove the junction box screws (65) and lock washers (37) and lower the junction box (63).
3. Remove screw (71) and disconnect harness connector (A) from the control module in the junction box.
4. Remove screws (303) and lock washers (304), disconnect all wires.
5. Install new control module. Reconnect all wires.
6. Work backwards from step 3 to reassemble.

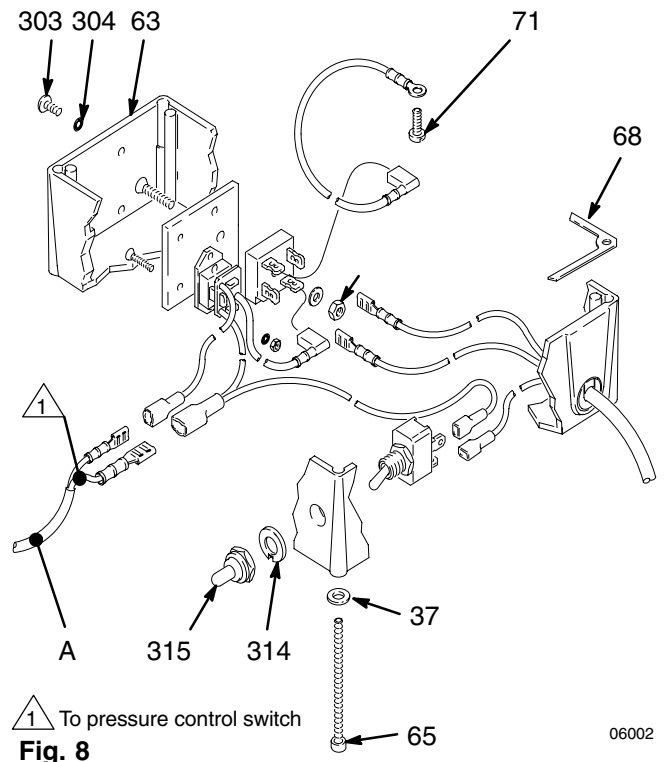

ON/OFF Switch

⚠ WARNING

INJECTION HAZARD
To reduce the risk of serious injury, whenever you are instructed to relieve pressure, follow the **Pressure Relief Procedure** on page 12.

1. Relieve pressure.
2. Remove the junction box screws (65) and lock washers and remove the junction box (63).
3. Remove the ring (314) and rubber boot (315).

4. Disconnect the red wires from the ON/OFF switch and remove the switch.
5. Install the switch so the internal tab of the anti-rotational ring engages with the vertical groove in the threads of the switch and the external tab engages with the blind hole of the junction box.
6. Powder the inside of the rubber boot (315) with talcum, then shake the excess out of the boot. Install the nut and rubber boot and tighten.
7. Reconnect the ON/OFF switch red wires.
8. Install the junction box. Be sure no leads are pinched against the mounting face. Also be sure the gasket (68) is installed.

Pressure Transducer

WARNING



INJECTION HAZARD

To reduce the risk of serious injury, whenever you are instructed to relieve pressure, follow the **Pressure Relief Procedure** on page 12.

NOTE: See Fig. 9 for this procedure.

1. Remove the displacement pump. See page 31.
2. Use a pull-twist motion to remove the transducer (22) from the pump manifold.
3. Clean paint residue from the hole in the manifold; do not scratch the surface of the hole.
4. Lightly apply oil to the o-ring of the new transducer.
5. Install the transducer in the pump manifold, while guiding the o-ring and backup ring into place.
6. Align the holes in the transducer as shown by the arrows in Fig. 9.
7. Install the displacement pump. See page 32.

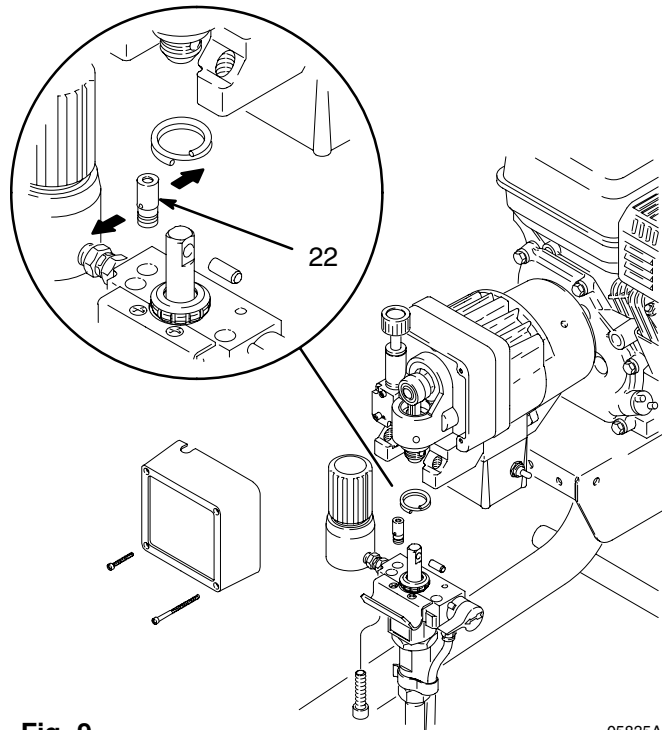

Fig. 9

05835A

Suction Hose

Models 231550 and 231552

WARNING



INJECTION HAZARD

To reduce the risk of serious injury, whenever you are instructed to relieve pressure, follow the **Pressure Relief Procedure** on page 12.

1. Separate the drain hose (31) from the suction hose (32).
2. Pull upward on the hose (32) while unscrewing it from the inlet tube (40). The hose coupling (A) threads will engage and the hose will separate from the tube.
3. Replace the o-ring (110) if it is worn or damaged.
4. Lubricate the o-ring (110) and the inlet tube (40) threads with light grease.
5. Align the suction hose coupling with the threads of the inlet tube (40). Tighten the hose onto the tube at least 4 turns to ensure that the threads have disengaged and can function as a swivel joint.

CAUTION

Misalignment or cross-threading will damage the parts and/or create shavings which can cause the o-ring (110) to leak.

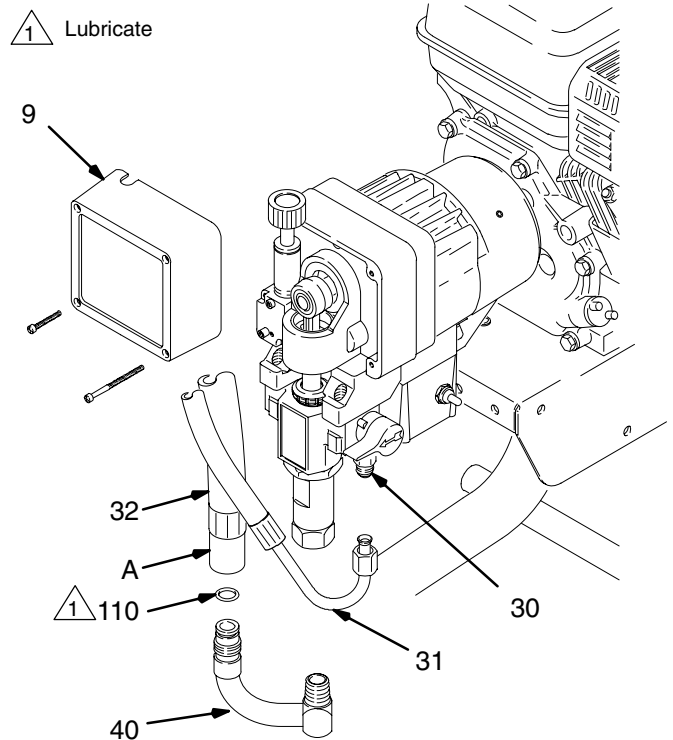

Model 231550 Shown

06004A

Fig. 10

Drain Valve

WARNING



INJECTION HAZARD

To reduce the risk of serious injury, whenever you are instructed to relieve pressure, follow the **Pressure Relief Procedure** on page 12.

Repair

1. Unscrew the spring retainer (43h) from the valve body. Remove the spring, washers and stem/ball. Clean any debris from the ball or seat area.
2. If replacing the gasket (43a) or seat (43b), pry out the gasket.

NOTE: Whenever the gasket (43a) is removed, replace it with a new one.

3. Coat the o-ring (43d) with grease. Press the stem into the valve body. Install the spring, washers and spring retainer into the valve body.
4. Place the seat (43b) in the valve body so the lapped side is toward the ball. Apply a small amount of grease to the new gasket (43a) and install it in the valve body.

NOTE: The gasket will protrude from the end of the valve until the valve is tightened into pump, which correctly seats the gasket.

Replacement





1. Apply a small amount of thread sealant onto the valve (43) threads. Tighten the valve into the pump manifold to 185 in-lb (21 N.m).
2. Lightly grease the face of the base (44) and install the base. Turn the stem so the pin hole is vertical.
3. Securely install the handle (46) and drive pin (45).

WARNING



INJECTION HAZARD

To reduce the risk of serious injury, keep the drain valve clean. Check drain valve operation before spraying.

- 1  Apply thread sealant
- 2  Apply grease to face of base
- 3  Torque into pump manifold to 140 in-lb (16 N.m)
- 4  Handle shown in closed position

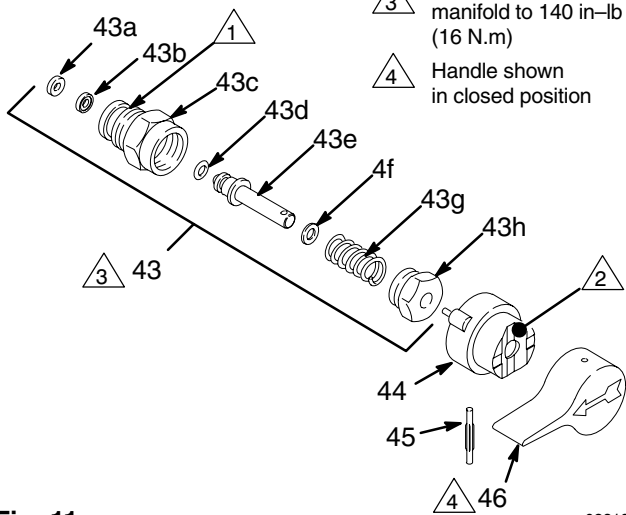

Fig. 11

02819

1. Turn the handle (46) to the closed position. Drive out the pin (45). Remove the handle.
2. Remove the base (44).
3. Unscrew the drain valve (43). The gasket (43a) and seat (43b) will stay in the valve.

Pinion, Clutch, Clamp, Field, & Engine

If servicing clutch components only, see page 25.

If no service is needed for internal parts of pinion housing, remove drive assembly (drive and pinion housing) from clutch housing. See page 25.

Pinion Housing Removal

⚠ WARNING

INJECTION HAZARD
To reduce the risk of serious injury, whenever you are instructed to relieve pressure, follow the **Pressure Relief Procedure** on page 12.

NOTE: Refer to Fig. 12 for Steps 1 to 5.

1. Follow the **Pressure Relief Procedure**, page 12.
2. If the drive housing has not yet been removed, follow steps 1 through 5 of **DRIVE HOUSING**, on page 16.
3. Remove the two bottom screws (59) and lockwashers (16) first, then remove the top three screws (59) and lockwashers (16).
4. Pull the pinion housing (2) away from the clutch housing (1). The armature (51b) will come with it.
5. Pull the armature (51b) off the hub (2h**) of the pinion housing. Also see Fig. 13.
6. If replacing the complete pinion housing assembly (2), brush G-n lubricant (supplied) on the pinion shaft teeth. Then recoat the pinion shaft teeth with bearing grease (supplied). Pack the remaining bearing grease in the bottom part of the pinion housing. Use 0.08 pint of the bearing grease.
7. Install new gasket (64) (supplied).

8. Reassemble to drive housing.

⚠ CAUTION

Do not lose the thrust ball (2d). Refer to the **CAUTION** on page 16 for more information

NOTE: To disassemble the pinion, go to page 24. To disassemble more of the sprayer, go to page 25. To reassemble the sprayer from this point, skip ahead to **Reassembly**, page 30, Step 8.

- 1 See page 24.
- 2 Brush with G-n lubricant.
- 3 Pack with bearing grease (0.08 pint)

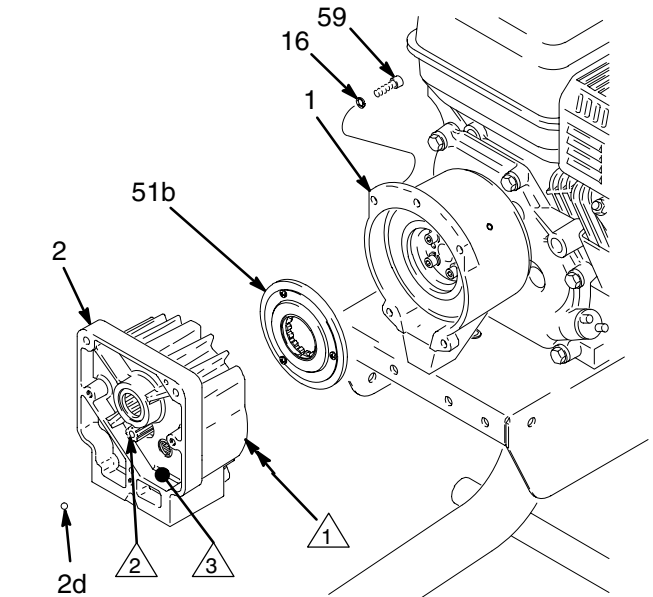

Fig. 12

05836C

Pinion Housing

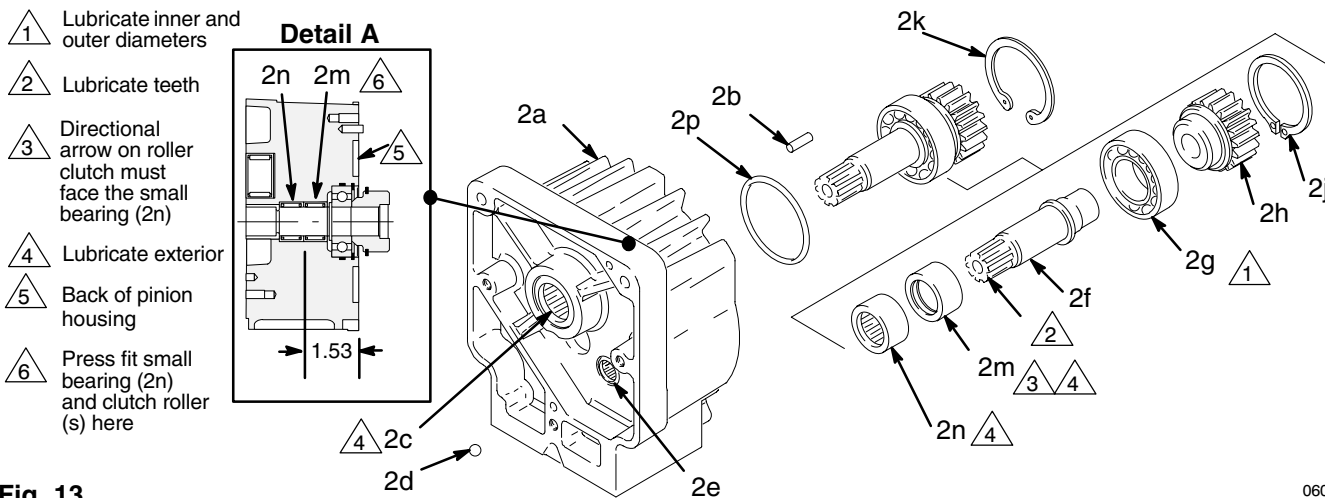

Fig. 13

06005

Repairing the Pinion (Fig. 13)

NOTE: Use a hydraulic press if you purchase the pinion parts individually. Otherwise, use Repair Kit No. 223189, which includes the shaft and bearings assembled and lubricated.

If using Repair Kit 223189, follow Steps 1 to 7, below.

1. Remove the small ring (2j) from the hub (2h) and the large ring (2k) from the bearing recess of the housing (2a).
2. Push on front of the shaft (2f) to force the bearing and hub assembly out of the housing (2a).
3. Press the small bearing (2n) and roller clutch (2m) out of the pinion housing (2a). Remove the new bearing and roller clutch from the shaft of the kit and press it into the housing to the dimension shown. Directional arrow of roller clutch (2m) must face bearing (2n). See Detail A.
4. Inspect o-ring (2p) and replace if necessary.
5. Install the shaft assembly, pushing it to the shoulder of the housing (2a).
6. Install rings (2k and 2j). Ring (2k) must be installed with bevel facing back of pinion housing.
7. Go to **Reassembly**, page 29, Step 7, or continue on page 24.

If you purchased parts separately, follow steps 1 to 9, below. Disassemble only as far as needed for the parts being replaced.

NOTE: The old bearing (2g) will be damaged as it is removed. Have one on hand if you need to remove it for any reason. Always replace bearing 2g if installing a new hub 2h.

1. To replace small bearing (2n) or roller clutch (2m), press the old one out of the pinion housing (2a).

2. Remove the small ring (2j) from the hub (2h). Remove the snap ring (2k) from the bearing recess of the housing (2a).

KEY

- A Round steel bar to push on shaft (2f)
- B Hydraulic press
- C Steel bar stock
- D Two steel blocks
- E Press platform

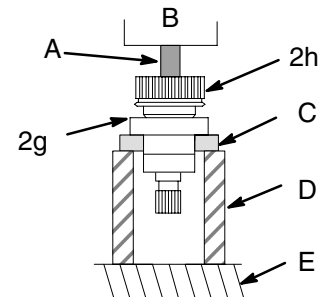

Fig. 14

01427

3. Push on the front of the shaft (2f) to force the bearing and hub assembly out of the housing (2a).
4. **Using a hydraulic press,** place pieces of steel bar stock on the inner race of the large bearing (2g) and press the shaft through the hub and bearing. See Fig. 14.
5. Apply lubricant to the parts as shown in Fig. 13.
6. Press fit the following parts:
 - Small bearing (2n) and then the roller clutch (2m), with the directional arrow facing the small bearing, into the rear of the housing (2a). See Detail A in Fig. 13.
 - Large bearing (2g) to shoulder of shaft (2f).
 - Hub (2h) onto the shaft (2f) all the way to the large bearing (2g).
7. Install the shaft assembly, pushing it to the shoulder of the housing (2a).
8. Install the rings (2k and 2j).
9. Skip ahead to **Reassembly**, page 30, Step 8, or continue on page 25.

Clutch

⚠ WARNING



INJECTION HAZARD

To reduce the risk of serious injury, whenever you are instructed to relieve pressure, follow the **Pressure Relief Procedure** on page 12.

NOTE: The clutch assembly (51) includes the armature (51b) and rotor (51a). The armature and rotor must be replaced together so they wear evenly. A new hub (2h) should be installed as well to ensure long clutch life.

NOTE: If the drive assembly (D) is not yet separated from the clutch housing (1), follow Steps 1 to 4. Otherwise, start at Step 5.

NOTE: Refer to Fig. 15 for this procedure.

1. Follow the **Pressure Relief Procedure**, page 12.
2. Remove the two bottom screws (59) and lockwashers (16) first, then remove the top three screws (59) and lockwashers (16).

⚠ CAUTION

The sprayer may become out of balance with the drive housing and pinion housing removed. Support the rear of the cart to prevent the partially disassembled sprayer from falling over.

3. Pull the drive assembly (D) away from the clutch housing (1).
4. The armature (51b) will move with the drive assembly. Remove the armature from the pinion hub (2h).

⚠ CAUTION

Examine the splined hub (2h**, Fig. 13, page 24) for wear. Replace as needed. Follow the Pinion Housing instructions, page 24.

5. There are two ways to remove the rotor (51a).
 - a. Remove the four socket head capscrews (57) and lockwashers (16). Install two of the screws in the threaded holes (E) in the rotor. Alternately tighten the screws until the rotor comes off. See Fig. 15.
 - b. You can use a standard steering wheel puller (A). However, two 1/4–28 x 3 or 4 in. long screws (B) are also needed. Replace the short screws of the steering wheel puller with the longer screws (B). Turn the screws (B) into the threaded holes (E) of the rotor (51a). Tighten the capscrew (C) of the tool until the rotor comes off. See the Detail in Fig. 15.
6. Skip ahead to **Reassembly**, page 30, Step 6, or continue on page 26.

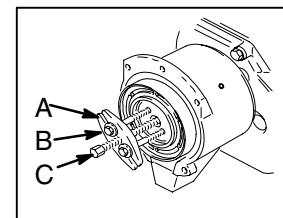
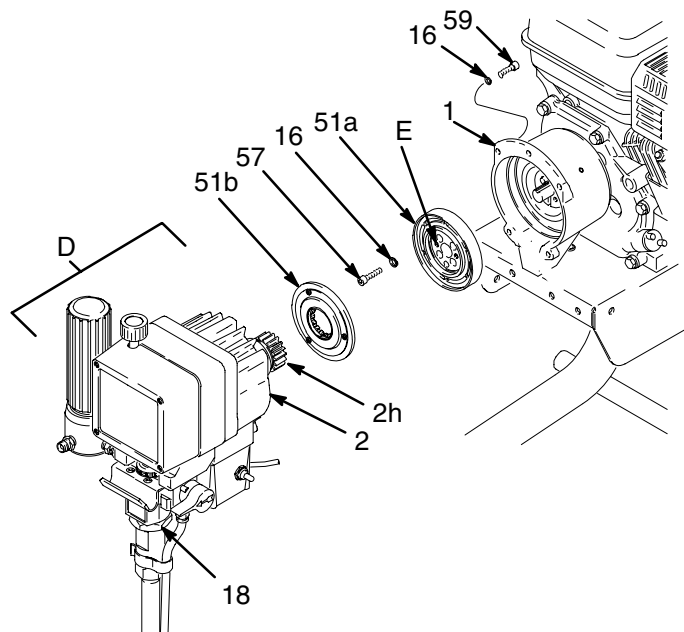

Fig. 15

05837C

Engine

NOTE: The engine must be removed before the Clamp and Clutch Housing can be removed.

⚠ CAUTION

The sprayer will be out of balance when the engine, clutch housing, drive housing and pinion housing are removed. Support the rear of the cart to prevent the partially disassembled sprayer from falling over.

⚠ CAUTION

The sprayer will experience poor clutch life if a replacement engine is purchased from another vendor. The engine for this sprayer is manufactured by Honda to a special Graco specification.

1. Working under the mounting plate (A), remove the two lock nuts (78) and then pull the screws (77) out of the base of the engine. Remove the screw (61). Disconnect the red wire (B) from the engine lead (D). Disconnect the black and white wires from the field. Pull the cable (E) carefully through the grommet (50) before removing the engine. See Fig. 16 and 17.
2. Lift the engine carefully and place it on a work bench.
3. Remove the **Field and Wiring Harness, Clamp and Clutch Housing**, as instructed on page 27.

NOTE: All service to the engine must be performed by an authorized Honda dealer.

⚠ 1 To engine alternator.

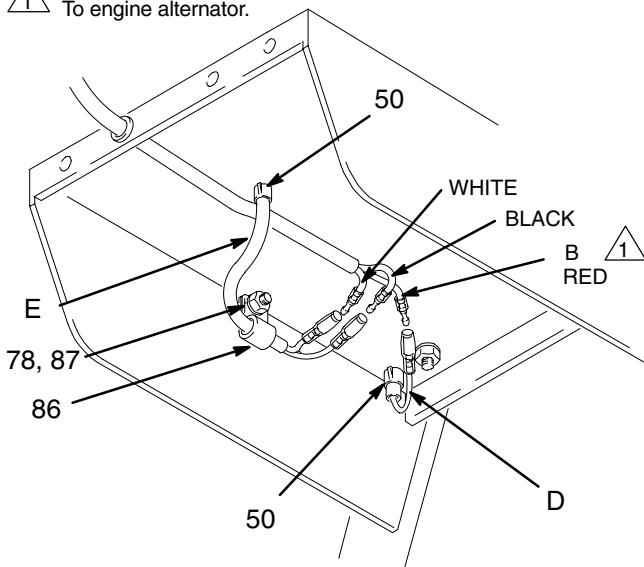

Bottom View of Engine and Cart

06006A

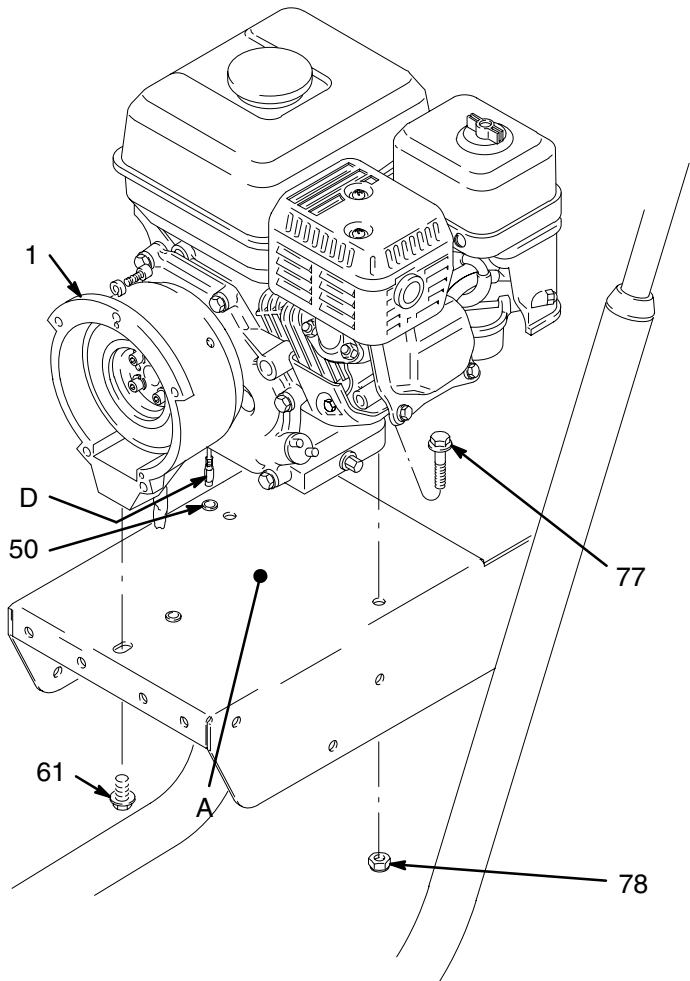

Fig. 17

06903

Fig. 16

Field & Wiring Harness

NOTE: Refer to Fig. 18.

1. Back out the four setscrews (58) holding the field (53) to the clutch housing (1) approximately 3 turns.
2. Pull out the field. The field fits closely to the clutch housing and must be removed carefully to prevent jamming.
3. Pull the plastic caps (B) off the wire screws (79) in both places on the field. Remove the screws and remove the wire (A).
4. Skip ahead to **Reassembly**, page 28, Step 4 or continue on page 27.

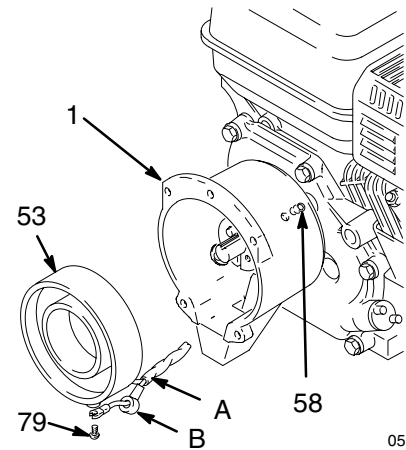

Fig. 18

05839

Clamp

NOTE: A standard steering wheel puller and two 1/4–28 x 3 or 4 in. long screws are required to remove the clamp.

NOTE: Refer to Fig. 19.

1. Loosen the two screws (57) on the clamp (55), working through the slot at the bottom of the clutch housing (1).
2. Install two screws (B) of the tool (A) in two of the threaded holes in the clamp (55). Tighten the screw (C) until the clamp comes off.
3. Skip ahead to **Reassembly**, page 28, Step 2, or continue below.

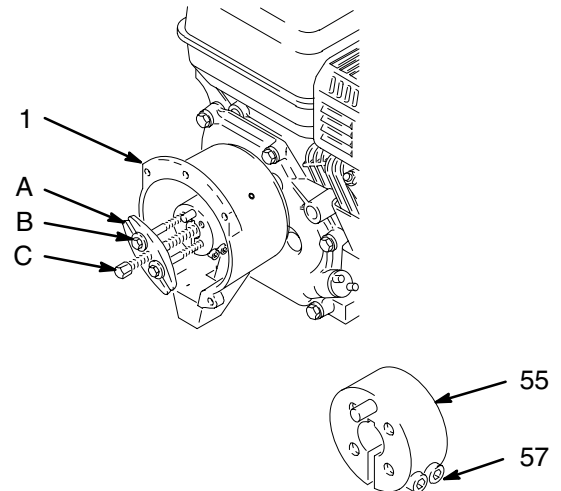

Fig. 19

05840

Clutch Housing

NOTE: Refer to Fig. 20.

CAUTION

If the clutch housing is removed from the engine a special alignment tool is required to reinstall it.

1. Remove the four capscrews (83) and lockwashers (84) which hold the clutch housing (1) to the engine.
2. Remove the engine key (56).
3. Pull off the clutch housing (1).
4. Skip ahead to **Reassembly**, page 28, Step 1.

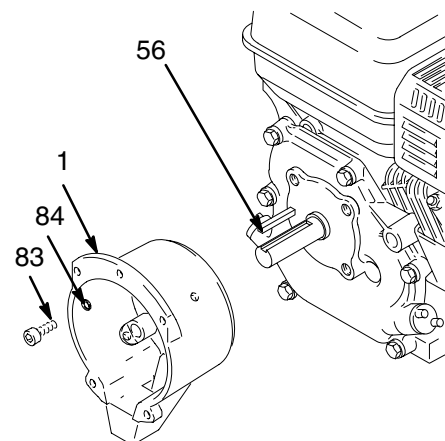

Fig. 20

05841A

Reassembly

⚠ CAUTION

The sprayer will be out of balance when only the engine and clutch housing are installed. Support the rear of the cart to prevent the sprayer from falling over.

1. Install the **clutch housing (1)**, capscrews (83) and lockwashers (84) on the engine. Use special alignment tool to position clutch housing on engine. Torque screws (83) to 200 in-lb (22 N.m).
2. Install the engine shaft **key (56)**. See Fig. 21.
3. Press the **clamp (55)** onto the engine shaft (A). Maintain the 1.41 inch ± 0.01 (35.8 ± 0.25 mm) dimension shown in Fig. 22.

4. Connect the wires of the harness (D) with the screws (79) in both places on the field (wires can be attached to either connection). Pull the plastic caps (C) up and snap them over the screws. Install the field in the clutch housing. Push the wire harness through the slot in the clutch housing. Align the setscrew holes in the field and the clutch housing (1). Hand tighten the setscrews (58) oppositely and evenly. See Fig. 21.

- 1 Torque the screws oppositely and evenly to 25 in-lb (2.8 N.m).
- 2 Slot.
- 3 Torque the screws to 200 in-lb (22 N.m).
- 4 Apply low strength thread locker to set screws (58).
- 5 Torque the screws to 120 in-lb (14 N.m).

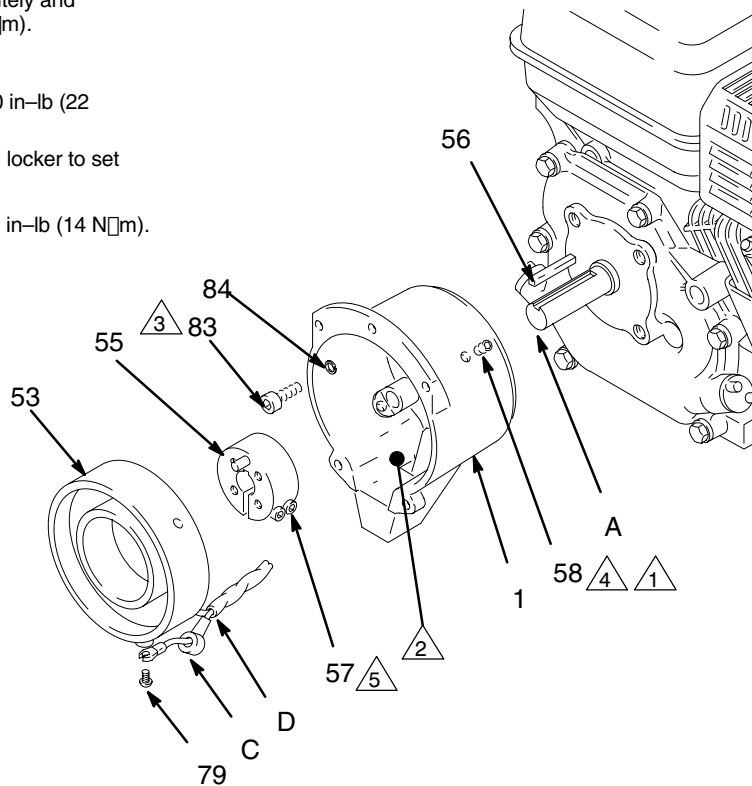

Fig. 21

05842A

Reassembly

- 1 The face of the housing.
- 2 1.41 ± .010 inch (35.8 ± .25 mm).
- 3 Torque the screws to 120 in-lb (14 N.m).

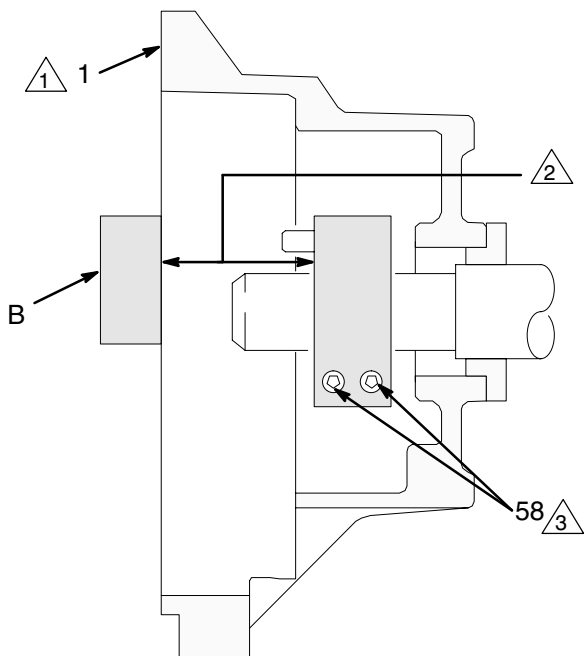

Fig. 22

05078

CAUTION

The sprayer will be out of balance when only the engine and clutch housing are installed. Support the rear of the cart to prevent the sprayer from falling over.

5. Place the **engine (48)** assembly on the cart. Align the mounting holes. Carefully guide the engine wire and wiring harness (E) from the field, through the appropriate grommets (50) in the mounting plate (A). Install the flange screws (77) and lock-nuts (78). Install the screw (61). Tighten all three screws. Connect the engine wire to the red wire (B), and connect the black and white wires as shown in the Detail drawing in Fig. 16.

Reassembly

- Be sure the face of the **rotor (51a)** and the clamp (55) are free of all burrs. Install the rotor, lock-washers (16) and capscrews (57). Torque the capscrews to 7 ft-lb (9.5 N.m). See Fig. 23.
- After installing the rotor (51a) the air gap must be adjusted between the rotor and the field (53). Tighten the setscrews (58) oppositely and evenly. Pull the engine recoil rope to assure that the engine turns freely, and there is no contact between the rotor and the field. If there is contact, loosen the setscrews and reposition the field.

NOTE: With the autogap style armature, the gap between the rotor and the armature is critical for proper operation. The clutch kits with an autogap style armature include a cardboard spacer (p/n 186857) to set the proper gap. This spacer is for use only during installation.

- Clean the face of the **armature (51b)**. With the flat side of the armature facing the rotor (51a), slide the armature onto the hub (2h) in the drive/pinion assembly (D) just until the chamfered end of the hub (2h) protrudes through the armature. See Detail B, Fig. 23. There will be significant resistance. Attach the cardboard spacer, supplied with the clutch kit, to the face of the armature. Bend tabs over outside diameter of armature.

Brace the cart against a wall to keep it from rolling. Push the drive/pinion assembly onto the clutch housing (1). There will be significant resistance. When the mating surfaces of the drive/pinion assembly and the clutch housing (1) are flush, remove the drive/pinion assembly. **Remove the cardboard spacer.**

- Assemble the **drive assembly (D)** to the clutch housing (1), using the capscrews (59) and lock-washers (16). See Fig. 23.

- | | | | |
|---|--|---|-----------------------------------|
| 1 | Torque the screw to 7 ft-lb (9.5 N.m). | 5 | Chamfered end of hub (2h) |
| 2 | The face must be clean. | 6 | Apply low strength thread locker. |
| 3 | To engine alternator. | 7 | Torque to 100 in.-lb (N-m). |
| 4 | Spline | | |

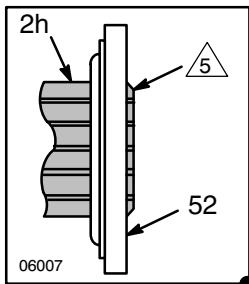

Detail B

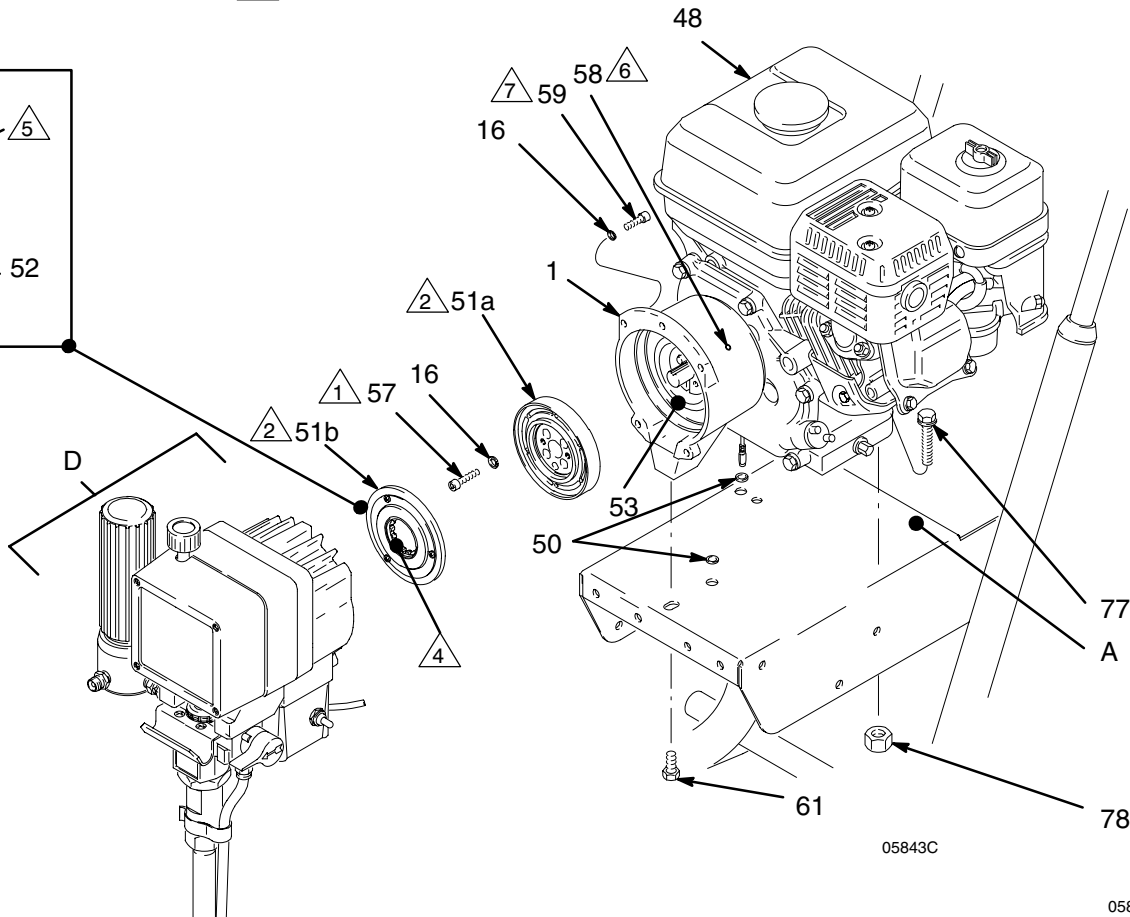

Fig. 23

Displacement Pump Repair

⚠ WARNING



INJECTION HAZARD

To reduce the risk of serious injury, whenever you are instructed to relieve pressure, follow the **Pressure Relief Procedure** on page 12.

NOTE: Packing Repair Kit 235703 is available. Reference numbers of parts included in the kit are marked with an asterisk, i.e., (121*). For the best results, use all the new parts in the kit, even if the old ones still look good.

NOTE: To minimize down time, and for the best sprayer performance, clean the transducer (see page 20) whenever you repack the pump. Replace these parts as needed.

Removing the pump (See Fig. 24.)

1. Flush the pump, if possible. Relieve pressure. Stop the pump with the piston rod (107) in its lowest position, if possible.
2. Remove the filter (21).
3. Remove suction hose or tube (40). (For suction hose, refer to page 21.)

NOTE: If repairing only the intake valve assembly, go to **Intake valve repair**, in manual 308190.

4. Use a screwdriver to push the retaining spring (12) up and push out the pin (11).
5. Loosen the screws (17). Remove the pump (18).

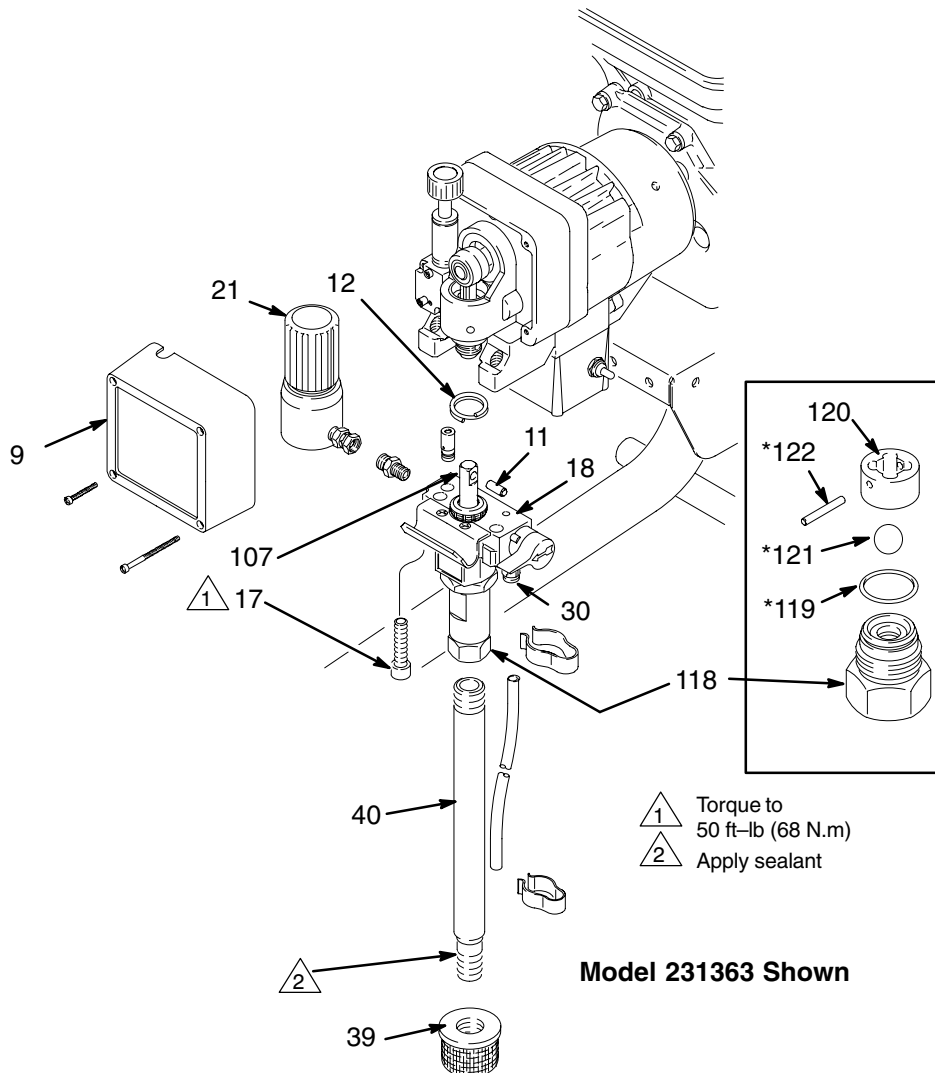

Fig. 24

05844

Displacement Pump Repair

Repairing the pump

See manual 308190 for pump repair instructions.

Installing the pump (See Fig. 24 and 25.)

1. Mount the pump on the drive housing. Tap it into the alignment pins with a soft hammer. Tighten the screws (17) to 50 ft-lb (68 N.m).

4. Tighten the packing nut (102) just enough to stop leakage, but no tighter. Fill the packing nut/wet-cup 1/3 full with Graco TSL. Push the plug (123) into the wet-cup.

⚠ WARNING



MOVING PARTS HAZARD

Be sure the retaining spring (12) is firmly in the groove all the way around, to prevent the pin (11) from working loose due to vibration. See Fig. 25.

If the pin works loose, it or other parts could break off due to the force of the pump action. These parts could be projected into the air and result in serious injury or property damage, including the pump connecting rod or drive housing.

2. Align the hole in the rod (107) with the connecting rod assembly (10). Use a screwdriver to push the retaining spring (12) up and push in the pin (11). Push the retaining spring (12) into place around the connecting rod.
3. Reconnect the suction and drain hoses. Install the front cover (9). On The lo-boy sprayer inspect the o-ring (110). Replace the o-ring if it is worn or damaged.

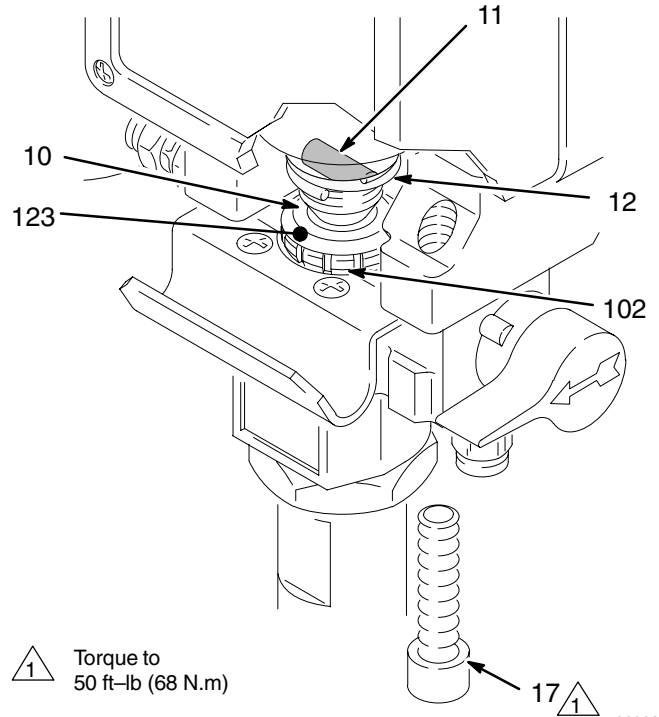

Fig. 25

0600E

Pressure Control Parts List

238672 Pressure Control for the GM3000 Sprayers

Ref No.	Part No.	Description	Qty	Ref No.	Part No.	Description	Qty
301	280340	HOUSING, box, junction	1	311	238676	CONDUCTOR, electrical	1
302	238660**	TRIAC	1	312**	191242	PLATE, module	1
303	100035	SCREW, panhead, 10-24 x 2 inch	2	313	105679	SWITCH, toggle	1
304	157021**	LOCKWASHER, No. 10	3	314	105658	RING, locking	1
305	108783**	SCREW, filhd,	1	315	105659	BOOT, toggle	1
306	100284**	NUT, hex	1	316	238791	CONDUCTOR, electrical	1
307	107070**	SCREW, flat hd	2	**Included in Repair Kit No. 238661.			
308	103181**	LOCKWASHER	2	▲ Replacement Danger and Warning labels, tags, and cards are available free.			
309	100072**	NUT, hex	2				
310	111936**	RECTIFIER, bridge	1				

Parts Drawing – Pressure Control

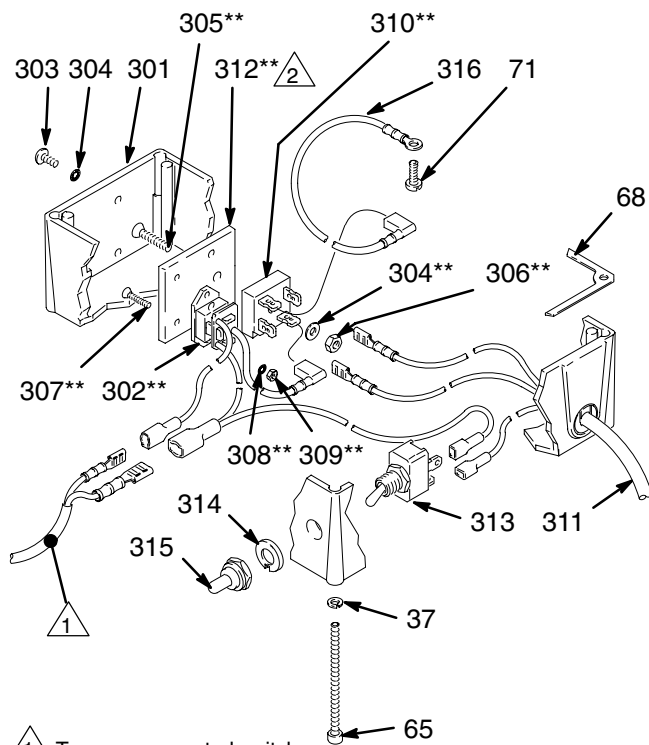

- 1 To pressure control switch
- 2 Apply thermopaste between 301 and 312;
310 and 312; 302 and 312

06002

Wiring Schematic – Pressure Control

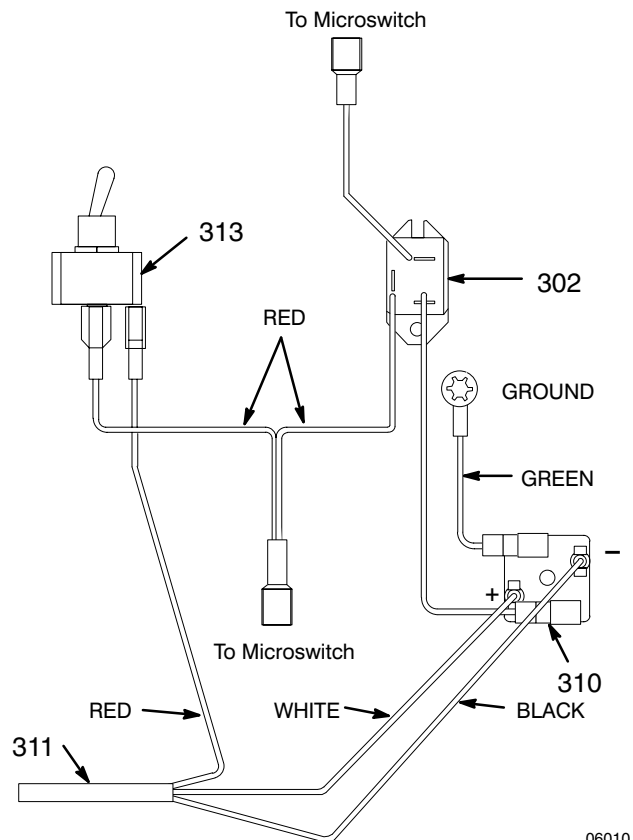



06010

Upright Sprayer Parts Drawing

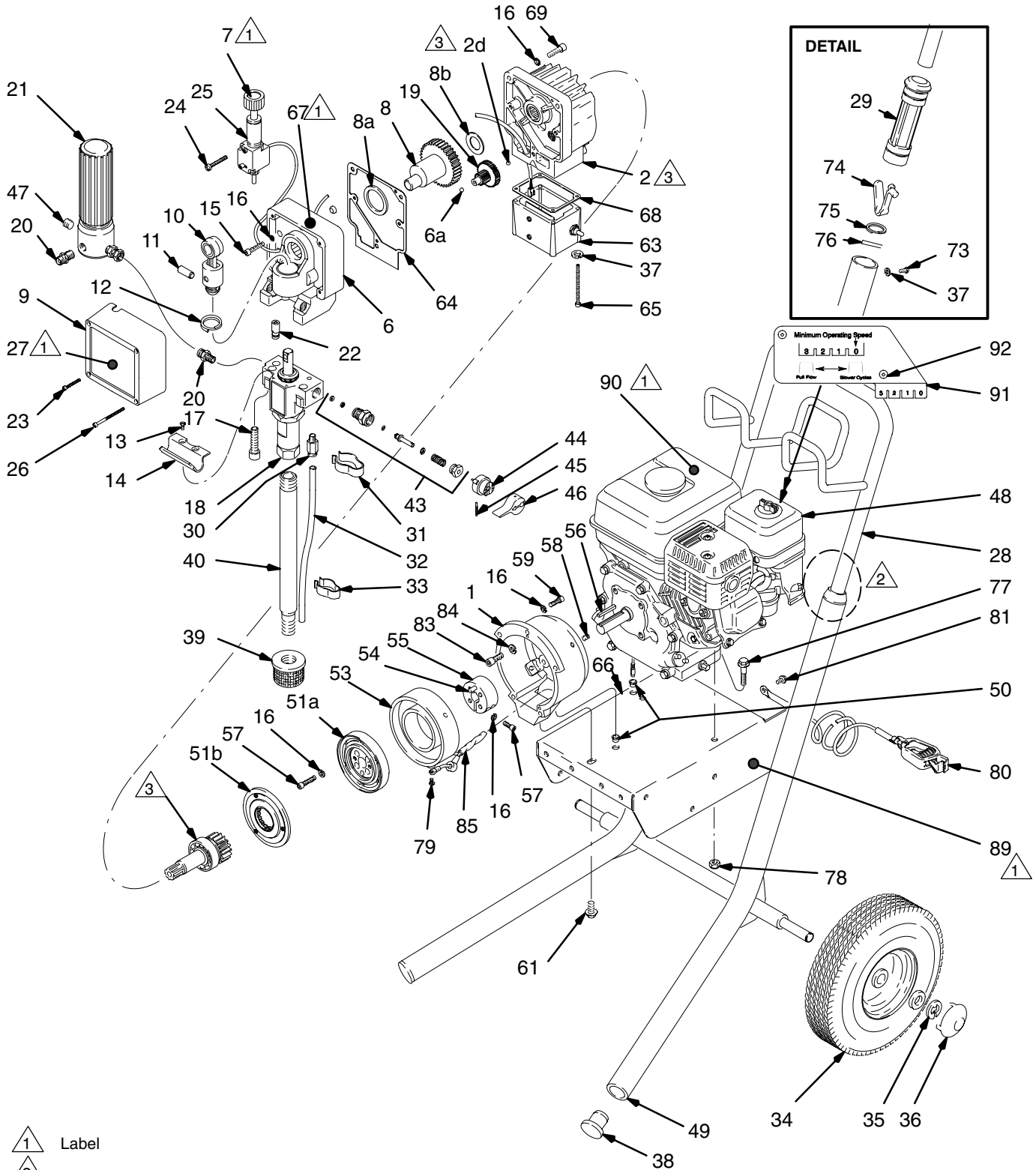
Model 231363



-  Label
-  See the detail, above.
-  See page 38 for the parts.

05846D

Upright Sprayer Parts List

Model 231363, Series A

Ref. No.	Part No.	Description	Qty.	Ref. No.	Part No.	Description	Qty.
1	191207	HOUSING, clutch	1	43h	187622	RETAINER, spring, valve	1
2	238684	HOUSING, pinion <i>See page 38 for parts</i>	1	44	224807	BASE, valve	1
6	238691	DRIVE HOUSING	1	45	111600	PIN, grooved, 3/32 x 1"	1
6a	100069	BALL	1	46	187625	HANDLE, drain valve	1
7	176904	LABEL, designation	1	47	100721	PLUG, pipe, headless, 1/4-18 nptf	1
8	235558	CRANKSHAFT	1	48	108879	ENGINE, gasoline	1
8a	180131	BEARING, thrust	1	49	239422	CART	1
8b	107434	BEARING, thrust	1	50	109099	BUSHING, snap	2
9	187789	COVER, front, blue	1	51	238798	CLUTCH ASSEMBLY	1
10	218359	CONNECTING ROD	1	51a		ROTOR, clutch	1
11	176818	PIN, headless, 3/8" dia. x 1"	1	51b		ARMATURE, clutch	1
12	176817	SPRING, retaining	1	53	238803	FIELD, clutch	1
13	112777	SCREW, mach, ovl hd, 10-24 x .375	2	54	108800	PIN, dowel, 5/16 x 1"	1
14	190321	HANGER, pail	1	55	188426	CLAMP, mounting, rotor	1
15	103345	SCREW, socket head, 1/4-20 x 1-1/4"	3	56	183401	KEY, parallel, 3/16" sq x 7/8"	1
16	105510	LOCKWASHER, 1/4"	16	57	108803	CAPSCREW, hex sch, 1/4-28 x 1.0"	6
17	111706	CAPSCREW, 7/16-14 x 1-3/4"	2	58	108801	SETCREW, 1/4"	4
18	235699	PUMP, displacement <i>See manual 308190 for parts</i>	1	59	100644	CAPSCREW, sch, 1/4-20 x 3/4"	5
19	238802	GEAR REDUCER	1	61	113802	CAPSCREW, hex hd, 3/8-16 x 5/8"	1
20	162453	NIPPLE, hex, 1/4 npsm x 1/4 npt, 1-3/16"	2	63	238672	PRESSURE CONTROL	1
21	239425	FILTER, fluid <i>See Manual 308249 for parts</i>	1	64	191258	GASKET, housing	1
22	235009	PRESSURE TRANSDUCER	1	65	111703	SCREW, filh, 10-24 x 3"	4
23	114415	SCREW, filh, 8-32 x 1-1/4"	1	66	189919	PLATE, designation	1
24	114416	SCREW, filh, 10-24 x 1-5/8"	2	67	290228	LABEL, caution	1
25	238799	SWITCH, pressure control	1	68	187963	GASKET	1
26	111705	SCREW, filh, 8-32 x 2-1/2"	3	69	100643	SCREW, socket head, 1/4-20 x 1"	2
27	290364	LABEL, identification, front	1	71	110637	SCREW, 10-24 X 3/8"	1
28	238187	HANDLE & HOSE RACK	1	72	290061	LABEL, warning	1
29	192027	SLEEVE	2	73	109032	SCREW, recess pnh, self-tap "F", No. 10-24 x 1/4"	4
30	108982	CONNECTOR, tube	1	74	112827	BUTTON, snap	2
31	181102	CLIP, spring	1	75	183350	WASHER, plain, 0.90"	2
32	186549	DRAIN TUBE	1	76	108068	PIN, spring, straight, 3/16"	2
33	186245	CLIP, spring	1	77	110837	SCREW, serrated flange, hex hd, 5/16-18 unc-2a x 1.5"	2
34	106062	WHEEL, semi-pneumatic	2	78	110838	LOCKNUT, heavy hex, 5/16-18	3
35	101242	RING, retaining, wheel	2	79	109033	SCREW, bdgh, 6-32 x 3/16"	2
36	104811	HUBCAP	2	80	237686	GROUNDING CLAMP & WIRE	1
37	100020	WASHER	4	81	112798	SCREW, mach thd, 1/4-20 x 0.375 <i>See Pressure Control Parts, page 33</i>	1
38	108691	PLUG, tubing	2	83	109031	CAPSCREW, 1/2 sch, 5/16-24 x 1"	4
39	183770	STRAINER, inlet, 1/2-14 npsm	1	84	104008	LOCKWASHER	4
40	192169	TUBE, suction	1	85	221183	CONDUCTOR, electrical	1
43	235014	DRAIN VALVE <i>See Fig. 11</i>	1	86	108868	CLAMP, wire <i>See Fig. 16</i>	1
43a	111699	GASKET	1	87	101344	SCREW, cap, 5/16-18 x 7/8" <i>See Fig. 16</i>	1
43b	187615	SEAT	1	89		LABEL, warning, See page 39	1
43c	187621	HOUSING, valve, drain	1	90	181867	LABEL, warning	1
43d	168110	O-RING	1	91	192014	PLATE, indicator	1
43e	224968	STEM, valve, drain	1	92	113684	RIVET, blind	2
43f	111599	WASHER, flat	1				
43g	187623	SPRING, compression	1				

▲ Extra warning labels available free of charge.

Lo-Boy Sprayer Parts Drawing

Model 231550, Series A

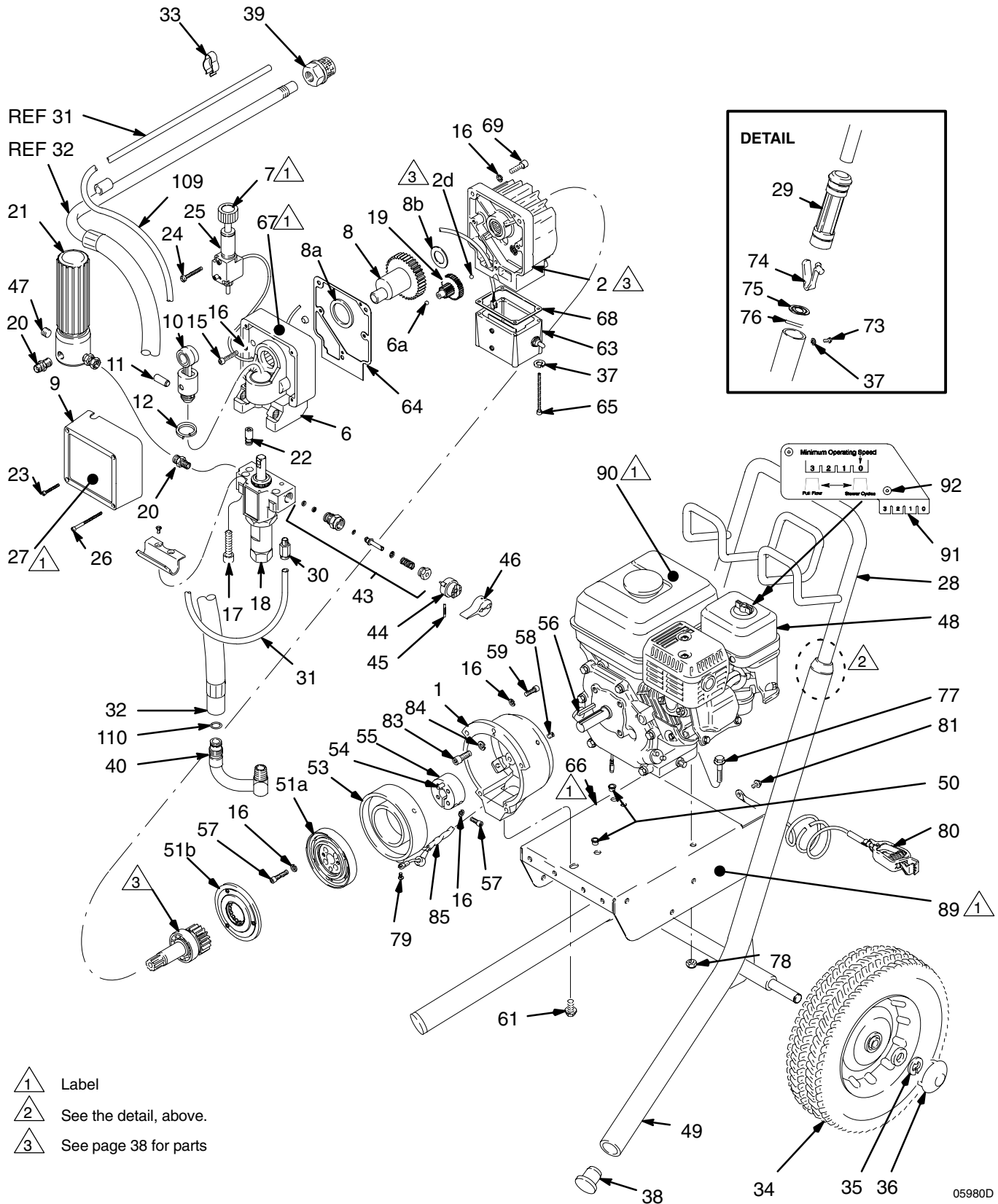

- 1 Label
- 2 See the detail, above.
- 3 See page 38 for parts

Lo-Boy Sprayer Parts List

Model 231550, Series A

Ref. No.	Part No.	Description	Qty.	Ref. No.	Part No.	Description	Qty.
1	191207	HOUSING, clutch	1	45	111600	PIN, grooved, 3/32 x 1"	1
2	238684	HOUSING, pinion <i>See page 38 for parts</i>	1	46	187625	HANDLE, drain valve	1
6	238656	DRIVE HOUSING	1	47	100721	PLUG, pipe, headless, 1/4-18 nptf	1
6a	100069	BALL	1	48	108879	ENGINE, gasoline	1
7	176904	LABEL, designation	1	49	238685	CART	1
8	235558	CRANKSHAFT	1	50	109099	BUSHING, snap	2
8a	180131	BEARING, thrust	1	51	238798	CLUTCH ASSEMBLY	1
8b	107434	BEARING, thrust	1	51a		ROTOR, clutch	1
9	187789	COVER, front, blue	1	51b		ARMATURE, clutch	1
10	218359	CONNECTING ROD	1	53	238803	FIELD, clutch	1
11	176818	PIN, headless, 3/8" dia. x 1"	1	54	108800	PIN, dowel, 5/16 x 1"	1
12	176817	SPRING, retaining	1	55	188426	CLAMP, mounting, rotor	1
15	103345	SCREW, socket head, 1/4-20 x 1-1/4"	3	56	183401	KEY, parallel, 3/16" sq x 7/8"	1
16	105510	LOCKWASHER, 1/4"	16	57	108803	CAPSCREW, hex sch, 1/4-28 x 1.0"	6
17	111706	CAPSCREW, 7/16-14 x 1-3/4"	2	58	108801	SETCREW, 1/4"	4
18	235699	PUMP, displacement <i>See manual 308190 for parts</i>	1	59	100644	CAPSCREW, sch, 1/4-20 x 3/4"	5
19	238802	GEAR REDUCER	1	61	113802	CAPSCREW, hex hd, 3/8-16 x 5/8"	1
20	162453	NIPPLE, hex, 1/4 npsm x 1/4 npt, 1-3/16"	2	63	238672	PRESSURE CONTROL	1
21	239425	FILTER, fluid <i>See Manual 308249 for parts</i>	1	64	191258	GASKET, housing	1
22	235009	PRESSURE TRANSDUCER	1	65	111703	SCREW, filh, 10-24 x 3"	4
23	114415	SCREW, filh, 8-32 x 1-1/4"	1	66	189919	PLATE, designation	1
24	114416	SCREW, filh, 10-24 x 1-5/8"	2	67	290228	LABEL, caution	1
25	238799	SWITCH, pressure control	1	68	187963	GASKET	1
26	111705	SCREW, filh, 8-32 x 2-1/2"	3	69	100643	SCREW, socket head, 1/4-20 x 1"	2
27	290364	LABEL, identification, front	1	71	110637	SCREW, 10-24 X 3/8"	1
28	238187	HANDLE & HOSE RACK	1	72	290061	LABEL, warning	1
29	192027	SLEEVE	2	73	109032	SCREW, recess pnh, self-tap "F", No. 10-24 x 1/4"	4
30	108982	CONNECTOR, tube	1	74	112827	BUTTON, snap	2
31	191640	TUBE, drain	1	75	183350	WASHER, plain, 0.90"	2
32	191619	TUBE, suction	1	76	108068	PIN, spring, straight, 3/16"	2
33	178342	CLIP, spring	2	77	110837	SCREW, serrated flange, hex hd, 5/16-18 unc-2a x 1.5"	2
34	106062	WHEEL, semi-pneumatic	2	78	110838	LOCKNUT, heavy hex, 5/16-18	3
35	101242	RING, retaining, wheel	2	79	109033	SCREW, bdgh, 6-32 x 3/16"	2
36	104811	HUBCAP	2	80	237686	GROUNDING CLAMP & WIRE	1
37	100020	WASHER	6	81	112798	SCREW, mach thd, 1/4-20 x .375 <i>See Pressure Control Parts, page 33</i>	1
38	108691	PLUG, tubing	2	83	109031	CAPSCREW, 1/2 sch, 5/16-24 x 1"	4
39	235004	STRAINER, inlet, 3/4-16 unf	1	84	104008	LOCKWASHER	4
40	187627	TUBE, suction	1	85	221183	CONDUCTOR, electrical	1
43	235014	DRAIN VALVE <i>See Fig. 11</i>	1	86	108868	CLAMP, wire <i>See Fig. 16</i>	1
43a	111699	GASKET	1	87	101344	SCREW, cap, 5/16-18 x 7/8" <i>See Fig. 16</i>	1
43b	187615	SEAT	1	89		LABEL, warning, See page 39	1
43c	187621	HOUSING, valve, drain	1	90	181867	LABEL, warning	1
43d	168110	O-RING	1	91	192014	PLATE, indicator	1
43e	224968	STEM, valve, drain	1	92	113684	RIVET, blind	2
43f	111599	WASHER, flat	1	109	103473	CLAMP, cable	2
43g	187623	SPRING, compression	1	110	104938	O-RING	1
43h	187622	RETAINER, spring, valve	1				
44	224807	BASE, valve	1				

▲ Extra warning labels available free of charge.

Parts List & Drawing – Complete Sprayers

Models 231551 and 231552

GM3000 Airless Paint Sprayer

Includes items 201 to 204

Ref No.	Part No.	Description	Qty
201	231363	GM3000 Upright Sprayer See parts list on page 35	1
	231550	GM3000 Lo-Boy Sprayer See parts list on page 37	1
202	240794	HOSE, grounded, nylon; 1/4 in. ID; cpld 1/4 npsm(fbe); 50 foot (15 m); spring guards both ends	1
203	238358	HOSE, grounded, nylon; 3/16 in. ID; cpld 1/4 npsm(m) x 1/4 npsm(f) swivel; 3 foot (0.9 m); spring guards both ends	1
204	246220	CONTRACTOR II SPRAY GUN Includes RAC® X HandTite™ Tip Guard and 517–size SwitchTip™ See 309639 for parts	1

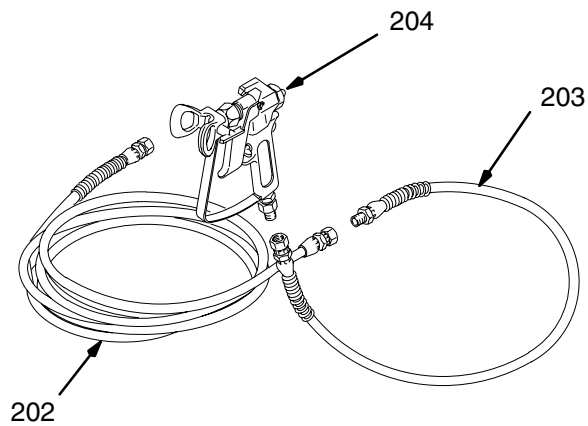

0160

Pinion Assembly Parts List and Drawing

Assembly 238684

Ref No.	Part No.	Description	Qty	Ref No.	Part No.	Description	Qty
2a	191208	.PINION HOUSING	1	2j**	108880	.RETAINING RING, small	1
2b	105489	.PIN	2	2k	113094	.RETAINING RING, large	1
2c	102873	.BEARING	1	2l**	191258	.GASKET, housing	1
2d	100069	.BALL	1	2m**	110607	.CLUTCH, roller	1
2e	107394	.BEARING	1	2n**	109001	.BEARING, needle	1
2f**	185916	.PINION SHAFT	1	2p**	165295	.O-RING	1
2g**	109002	.BALL BEARING, large	1				
2h**	183515	.HUB, armature	1				

**Included in Repair Kit No. 223189.

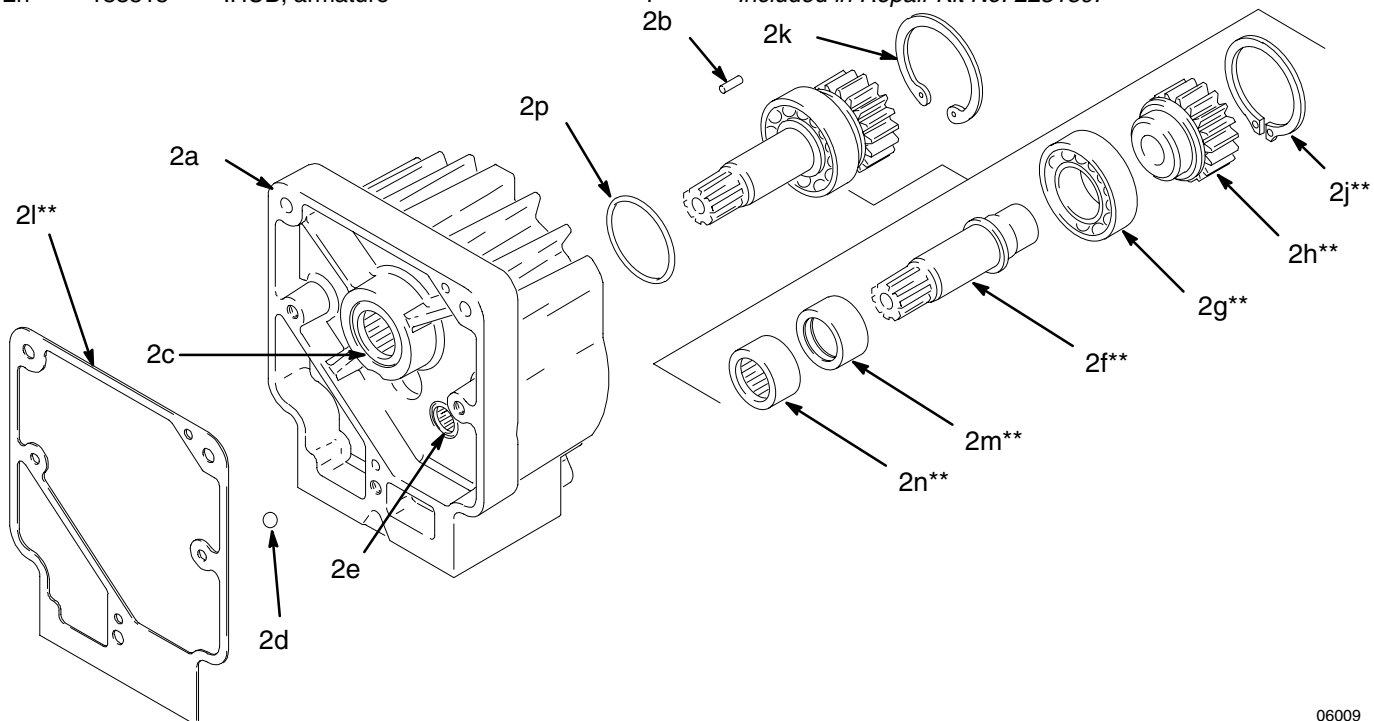

Accessories

- Displacement Pump Repair Kit** 235703
Parts included in the kit are shown in manual 308190.
- Hose 1/4 in. x 50 ft** 240794
1/4–18 npsm female swivel, both ends.
- Contractor II Spray Gun** 246220
RAC® X HandTite™ Tip Guard 246215
Safety feature that reduces the risk of injection injury.

DANGER LABELS

The English language DANGER label shown on page 4 is on your sprayer. If you have painters who do not read English, order one of the following labels to apply to your sprayer. The drawing below shows the best placement of these labels for good visibility.

Order the labels directly from Graco, free of charge. Toll Free: 1-800-328-0211 Apply other language here

- French** 187784
Spanish 185962
German 186042
Greek 186046
Korean 186047
English 187791

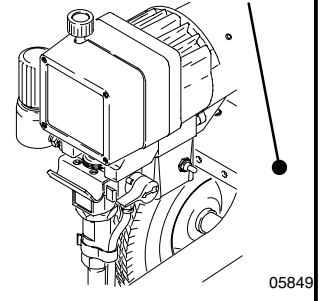

05849

Technical Data

- Honda GX120 Engine
Power Rating @ 3600 rpm
ANSI 4.0 Horsepower
DIN 6270B/DIN 6271
NA 2.1 Kw – 2.8 Ps
NB 2.6 Kw – 3.6 Ps
Maximum working pressure 3000 psi (210 bar, 21 MPa)
Noise level
Sound power 102 dB(A)
(per ISO-3744)
Sound pressure 87 dB(A)
Measured at 3.1 feet (1 m) under maximum operating conditions
Cycles/gallon (liter) 540 (142)
Maximum delivery 0.62 gpm (2.35 liter/min)
Fuel tank capacity 0.66 gallons (2.5 liter)

- Maximum tip size 0.025 @ 2000 psi
(137 bar, 13.7 MPa) with latex
Inlet paint strainer 12 mesh
stainless steel screen, reusable
Outlet paint filter 60 mesh (250 micron)
stainless steel screen, reusable
Pump inlet size 1/2 in. npt (f)
Fluid outlet size 1/4 in. npsm from fluid filter
Wetted parts
Displacement Pump stainless steel, carbon steel,
polyurethane, uhmw polyethylene,
aluminum, PTFE, Delrin®, leather
Filter aluminum, carbon steel, stainless steel
Pressure Control stainless steel, brass
Suction Hose Nitrile (synthetic rubber)with nylon lining
NOTE: Delrin® is a registered trademark of the DuPont Company.

Dimensions

Models 231363 & 231550

Weight (dry w/o packaging)	94 lb (43 kg)
Height	30 in. (762 mm)
Length	28 in. (711 mm)
Width	22 in. (589 mm)

Graco Phone Number

TO PLACE AN ORDER, contact your Graco distributor, or call this number to identify the distributor closest to you: **1-800-690-2894 Toll Free**

Graco Warranty

Graco warrants all equipment listed in this manual which is manufactured by Graco and bearing its name to be free from defects in material and workmanship on the date of sale by an authorized Graco distributor to the original purchaser for use. With the exception of any special extended or limited warranty published by Graco, Graco will, for a period of twelve months from the date of sale, repair or replace any part of the equipment determined by Graco to be defective. This warranty applies only when the equipment is installed, operated and maintained in accordance with Graco's written recommendations.

This warranty does not cover, and Graco shall not be liable for general wear and tear, or any malfunction, damage or wear caused by faulty installation, misapplication, abrasion, corrosion, inadequate or improper maintenance, negligence, accident, tampering, or substitution of non-Graco component parts. Nor shall Graco be liable for malfunction, damage or wear caused by the incompatibility of Graco equipment with structures, accessories, equipment or materials not supplied by Graco, or the improper design, manufacture, installation, operation or maintenance of structures, accessories, equipment or materials not supplied by Graco.

This warranty is conditioned upon the prepaid return of the equipment claimed to be defective to an authorized Graco distributor for verification of the claimed defect. If the claimed defect is verified, Graco will repair or replace free of charge any defective parts. The equipment will be returned to the original purchaser transportation prepaid. If inspection of the equipment does not disclose any defect in material or workmanship, repairs will be made at a reasonable charge, which charges may include the costs of parts, labor, and transportation.

Graco's sole obligation and buyer's sole remedy for any breach of warranty shall be as set forth above. The buyer agrees that no other remedy (including, but not limited to, incidental or consequential damages for lost profits, lost sales, injury to person or property, or any other incidental or consequential loss) shall be available. Any action for breach of warranty must be brought within two (2) years of the date of sale.

GRACO MAKES NO WARRANTY, AND DISCLAIMS ALL IMPLIED WARRANTIES OF MERCHANTABILITY AND FITNESS FOR A PARTICULAR PURPOSE IN CONNECTION WITH ACCESSORIES, EQUIPMENT, MATERIALS OR COMPONENTS SOLD BUT NOT MANUFACTURED BY GRACO. These items sold, but not manufactured by Graco (such as electric motors, gas engines, switches, hose, etc.), are subject to the warranty, if any, of their manufacturer. Graco will provide purchaser with reasonable assistance in making any claim for breach of these warranties.

In no event will Graco be liable for indirect, incidental, special or consequential damages resulting from Graco supplying equipment hereunder, or the furnishing, performance, or use of any products or other goods sold hereto, whether due to a breach of contract, breach of warranty, the negligence of Graco, or otherwise.

FOR GRACO CANADA CUSTOMERS

The parties acknowledge that they have required that the present document, as well as all documents, notices and legal proceedings entered into, given or instituted pursuant hereto or relating directly or indirectly hereto, be drawn up in English. Les parties reconnaissent avoir convenu que la rédaction du présente document sera en Anglais, ainsi que tous documents, avis et procédures judiciaires exécutés, donnés ou intentés à la suite de ou en rapport, directement ou indirectement, avec les procédures concernées.

ADDITIONAL WARRANTY COVERAGE

Graco does provide extended warranty and wear warranty for products described in the "Graco Contractor Equipment Warranty Program".

*All written and visual data contained in this document reflect the latest product information available at the time of publication.
Graco reserves the right to make changes at any time without notice.*

Sales Offices: Minneapolis, Detroit
International Offices: Belgium, Korea, Hong Kong, Japan

<http://www.graco.com>
GRACO INC. P.O. BOX 1441 MINNEAPOLIS, MN 55440-1441

PRINTED IN U.S.A. 308620 March 1996, Revised 3/2003