

## Wall Mount Airless Packages

308756G



### Important Safety Instructions

Read all warnings and instructions in this manual.  
Save these instructions.

See page 2 for model numbers and maximum  
working pressures.

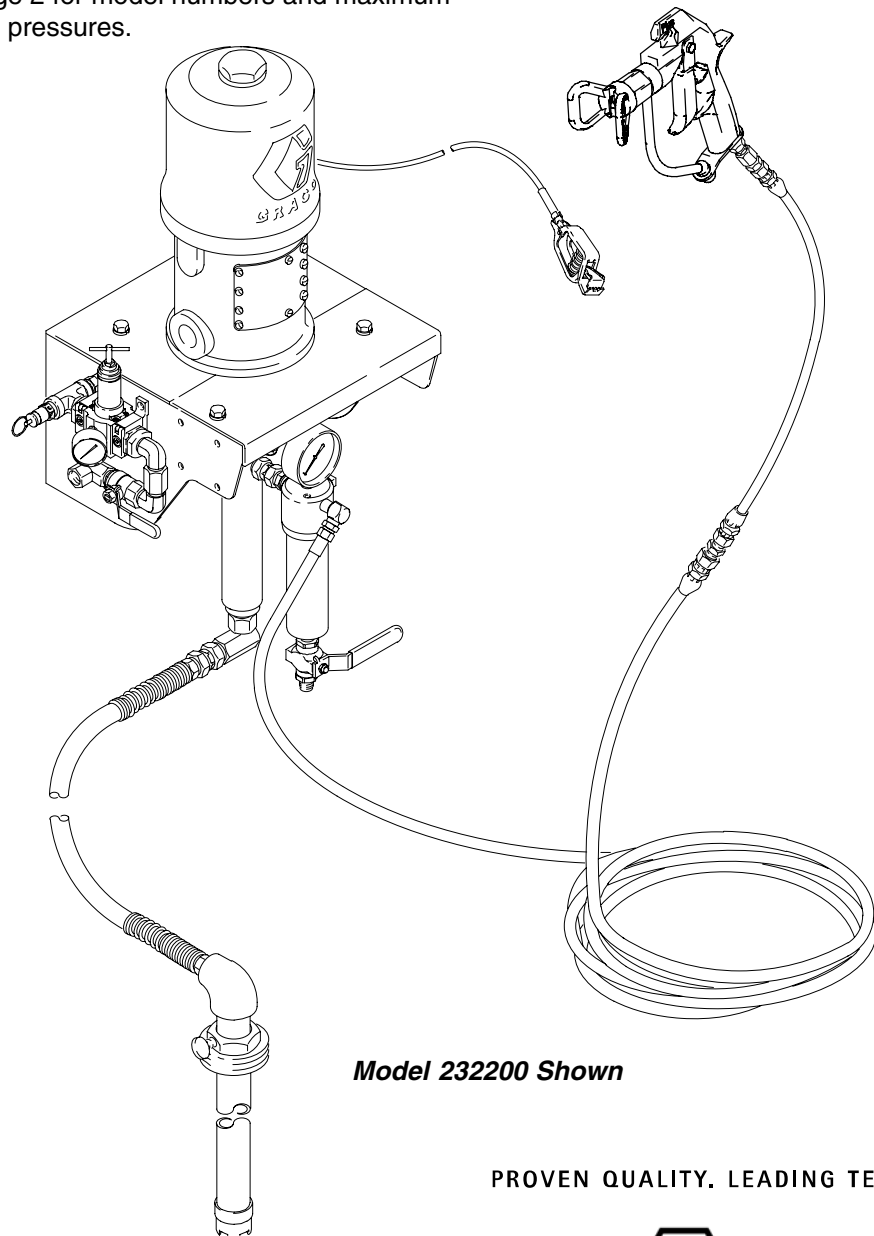

*Model 232200 Shown*

PROVEN QUALITY. LEADING TECHNOLOGY.

# Table of Contents

List of Models .....	2	Technical Data .....	20
Warnings .....	3	Dimensions .....	22
Installation .....	7	Mounting Hole Layout .....	23
Operation .....	11	Graco Standard Warranty .....	24
Maintenance .....	15	Graco Information .....	24
Parts .....	16		

## List of Models

Package Part No.	Series	Pump Model	Ratio	Maximum Fluid Working Pressure	Maximum Air Input Pressure
232200	A	President®, carbon steel	30:1	3000 psi (21 MPa, 210 bar)	100 psi (0.7 MPa, 7 bar)
232201	A	President®, carbon steel, without hose and gun	30:1	3000 psi (21 MPa, 210 bar)	100 psi (0.7 MPa, 7 bar)
232211	A	President®, stainless steel	30:1	3000 psi (21 MPa, 210 bar)	100 psi (0.7 MPa, 7 bar)
232212	A	President®, stainless steel, without hose and gun	30:1	3000 psi (21 MPa, 210 bar)	100 psi (0.7 MPa, 7 bar)
232222	A	Monark®, carbon steel	23:1	2300 psi (16 MPa, 160 bar)	100 psi (0.7 MPa, 7 bar)
232223	A	Monark®, carbon steel, without hose and gun	23:1	2300 psi (16 MPa, 160 bar)	100 psi (0.7 MPa, 7 bar)
232233	A	Monark®, stainless steel	23:1	2300 psi (16 MPa, 160 bar)	100 psi (0.7 MPa, 7 bar)
232234	A	Monark®, stainless steel, without hose and gun	23:1	2300 psi (16 MPa, 160 bar)	100 psi (0.7 MPa, 7 bar)
232263	A	President®, carbon steel	46:1	4600 psi (32 MPa, 317 bar)	100 psi (0.7 MPa, 7 bar)
232264	A	President®, carbon steel, without hose and gun	46:1	4600 psi (32 MPa, 317 bar)	100 psi (0.7 MPa, 7 bar)

# Symbols

## Warning Symbol



This symbol alerts you to the possibility of serious injury or death if you do not follow the instructions.

## Caution Symbol



This symbol alerts you to the possibility of damage to or destruction of equipment if you do not follow the instructions.

## WARNING



INSTRUCTIONS

### EQUIPMENT MISUSE HAZARD

Equipment misuse can cause the equipment to rupture or malfunction and result in serious injury.

- This equipment is for professional use only.
- Read all instruction manuals, tags, and labels before operating the equipment.
- Use the equipment only for its intended purpose. If you are uncertain about usage, call your Graco distributor.
- Do not alter or modify this equipment. Use only genuine Graco parts and accessories.
- Check equipment daily. Repair or replace worn or damaged parts immediately.
- Do not exceed the maximum working pressure of the lowest rated system component. Refer to the **Technical Data** on page 20 for the maximum working pressure of this equipment.
- Use fluids and solvents which are compatible with the equipment wetted parts. Refer to the **Technical Data** section of all equipment manuals. Read the fluid and solvent manufacturer's warnings.
- Route hoses away from traffic areas, sharp edges, moving parts, and hot surfaces. Do not expose Graco hoses to temperatures above 180°F (82°C) or below -40°F (-40°C).
- Wear hearing protection when operating this equipment.
- Do not lift pressurized equipment.
- Comply with all applicable local, state, and national fire, electrical, and safety regulations.

# WARNING

## SKIN INJECTION HAZARD



Spray from the gun, hose leaks, or ruptured components can inject fluid into your body and cause extremely serious injury, including the need for amputation. Fluid splashed in the eyes or on the skin can also cause serious injury.



- Fluid injected into the skin might look like just a cut, but it is a serious injury. **Get immediate surgical treatment.**
- Do not point the gun at anyone or at any part of the body.
- Do not put your hand or fingers over the spray tip.
- Do not stop or deflect leaks with your hand, body, glove or rag.
- Do not “blow back” fluid; this is not an air spray system.
- Always have the tip guard and the trigger guard on the gun when spraying.
- Check the gun diffuser operation weekly. Refer to the gun manual.
- Be sure the gun trigger safety operates before spraying.
- Lock the gun trigger safety when you stop spraying.
- Follow the **Pressure Relief Procedure** on page 11 whenever you: are instructed to relieve pressure; stop spraying; clean, check, or service the equipment; and install or clean the spray tip.
- Tighten all fluid connections before operating the equipment.
- Check the hoses, tubes, and couplings daily. Replace worn, damaged, or loose parts immediately. Permanently coupled hoses cannot be repaired; replace the entire hose.
- Use only Graco approved hoses. Do not remove any spring guard that is used to help protect the hose from rupture caused by kinks or bends near the couplings.



## MOVING PARTS HAZARD

Moving parts, such as the air motor piston, can pinch or amputate your fingers.

- Keep clear of all moving parts when starting or operating the pump.
- Before servicing the equipment, follow the **Pressure Relief Procedure** on page 11 to prevent the equipment from starting unexpectedly.

# WARNING



## FIRE AND EXPLOSION HAZARD

Improper grounding, poor ventilation, open flames or sparks can cause a hazardous condition and result in a fire or explosion and serious injury.

- Ground the equipment and the object being sprayed. Refer to **Grounding** on page 10.
- If there is any static sparking or you feel an electric shock while using this equipment, **stop spraying immediately**. Do not use the equipment until you identify and correct the problem.
- Provide fresh air ventilation to avoid the buildup of flammable fumes from solvents or the fluid being sprayed.
- Keep the spray area free of debris, including solvent, rags, and gasoline.
- Electrically disconnect all equipment in the spray area.
- Extinguish all open flames or pilot lights in the spray area.
- Do not smoke in the spray area.
- Do not turn on or off any light switch in the spray area while operating or if fumes are present.
- Do not operate a gasoline engine in the spray area.



## TOXIC FLUID HAZARD

Hazardous fluid or toxic fumes can cause serious injury or death if splashed in the eyes or on the skin, inhaled, or swallowed.

- Know the specific hazards of the fluid you are using.
- Store hazardous fluid in an approved container. Dispose of hazardous fluid according to all local, state and national guidelines.
- Always wear protective eyewear, gloves, clothing and respirator as recommended by the fluid and solvent manufacturer.



# Installation

## General Information

**NOTE:** Reference numbers and letters in parentheses in the text refer to the callouts in the figures and the parts drawing.

**NOTE:** Always use Genuine Graco Parts and Accessories, available from your Graco distributor. Refer to Product Data Sheet 305900. If you supply your own accessories, be sure they are adequately sized and pressure-rated for your system.

Fig. 1 is only a guide for selecting and installing system components and accessories. Contact your Graco distributor for assistance in designing a system to suit your particular needs.

## Prepare the Operator

All persons who operate the equipment must be trained in the safe, efficient operation of all system components as well as the proper handling of all fluids. All operators must thoroughly read all instruction manuals, tags, and labels before operating the equipment.

The following manuals are included with this equipment:

- 308756, Wall Mount Airless Packages
- 306981, President 30:1 CST Pump, or 308106, President 30:1 SST Pump, or 307619, President 46:1 CST and Monark 23:1 CST and SST Pumps
- 306982, President Air Motor, or 307043, Monark Air Motor
- 308686, Air Regulator Kit
- 307273, Fluid Filter
- 311254, Airless Spray Gun (Models 232200, 232211, 232222, 232233, and 232263 only)

## Prepare the Site

Ensure that the wall is strong enough to support the weight of the pump and accessories, fluid, hoses, and stress caused during pump operation.

Ensure that you have an adequate compressed air supply. Refer to the performance charts on page 21 to find the air consumption of your pump.

Refer to Fig. 1. Bring a compressed air supply line from the air compressor to the pump location. Be sure all air hoses are properly sized and pressure-rated for your system. Use only electrically conductive hoses. The air hose (A) should have a 3/8 npsm(m) thread.

Install a bleed-type shutoff valve (B) in the air line to isolate the air line components for servicing. Install an air line filter (C) and a moisture trap and drain valve (D) to help remove moisture and contaminants from the compressed air supply.

Keep the site clear of any obstacles or debris that could interfere with the operator's movement.

Have a grounded, metal pail available for use when flushing the system.

# Installation

## Supplied Components

Refer to Fig. 1.

### **WARNING**

A red-handled bleed-type master air valve (E) and a fluid drain valve (F) are supplied. These components help reduce the risk of serious injury, including fluid injection and splashing of fluid in the eyes or on the skin, and injury from moving parts if you are adjusting or repairing the pump.

The bleed-type master air valve relieves air trapped between this valve and the pump after the valve is closed. Trapped air can cause the pump to cycle unexpectedly. Locate the valve close to the pump.

The fluid drain valve assists in relieving fluid pressure in the displacement pump, hose, and gun. Triggering the gun to relieve pressure may not be sufficient.

- **The red-handled bleed-type master air valve (E)** is required in your system to relieve air trapped between it and the air motor when the valve is closed (see the **WARNING** above). Do not block access to the valve.
- **The pump air regulator (G)** controls pump speed and outlet pressure by adjusting the air pressure to the pump.
- **The air relief valve (H)** opens automatically to prevent overpressurization of the pump.
- **The air inlet swivel (K)** connects incoming air to the pump.
- **The suction hose (30) and tube (33)** allow the pump to draw fluid from a 55 gallon (200 liter) drum (L). Carbon steel models include a **bung adapter (34)** which screws into the drum's bung hole.
- **The fluid filter (15)** includes a 60 mesh (250 micron) stainless steel element to filter particles from the fluid as it leaves the pump. It also includes the **fluid drain valve (F)**, which is required in your system to relieve fluid pressure in the hose and gun (see the **WARNING** above).

- **The airless spray gun (106)** dispenses the fluid. The gun houses the **spray tip (107)**, which is available in a wide range of sizes for different spray patterns and rates of flow.
- The **fluid hose (101) and whip hose (103)** supply fluid to the gun.
- **The gun swivel (104)** allows greater gun maneuverability. On Monark models using a fine finish spray tip, the swivel includes an in-line filter.

## Installing the Pump

**NOTE:** Refer to Fig. 1 and to the Dimension drawing on page 22 and the Mounting Hole Layout on page 23.

1. Ensure that the wall is strong enough to support the weight of the pump and accessories, fluid, hoses, and stress caused during pump operation.
2. Position the bracket mounting plate (39) on the wall so the edge with the hook is facing up. Refer to page 23. Mount the plate so the top edge is 4 to 5 ft (1.2 to 1.5 m) above the floor. Check that the plate is level. Mark two holes on the wall, using the plate as a template. Drill two holes and attach the plate with 1/2 in. bolts and washers.
3. Using two people, lift the pump assembly into position and hang the pump bracket (1) on the bracket mounting plate (39). Have one person hold the assembly in place while the other checks that the pump bracket (1) is level. Mark four holes on the wall, using the pump bracket as a template. Lift the bracket off the mounting plate (39).
4. Drill four holes in the wall.

### **WARNING**

The pump bracket (1) must be bolted to the wall with four bolts. Do not simply hang the pump bracket on the bracket mounting plate (39).

5. Lift the pump assembly back into position, hang it on the bracket mounting plate (39), and bolt the pump bracket (1) to the wall. Use 1/2 in. bolts and washers to mount the pump module to the wall. Use bolts that are long enough to keep the pump bracket (1) from vibrating during operation.



# Installation

## KEY

### SUPPLIED COMPONENTS

- 1 Wall Bracket
- 10 Pump
- 15 Fluid Filter (includes fluid drain valve F)
- 22 Ground Wire (required; see page 10 for installation instructions)
- 30 Suction Hose
- 33 Suction Tube
- 34 Bung Adapter (carbon steel models only)
- 101 Electrically Conductive Fluid Hose
- 103 Fluid Whip Hose
- 104 Gun Swivel (includes in-line filter on Monark models)
- 106 Airless Spray Gun
- E\* Red-Handled Bleed-Type Master Air Valve (required, for pump)
- F Fluid Drain Valve
- G\* Pump Air Regulator
- H\* Air Relief Valve
- K\* Air Inlet Swivel
- \* Included in Air Regulation Kit (16).

### COMPONENTS YOU MUST SUPPLY

- A Electrically Conductive Air Supply Hose
- B Bleed-Type Master Air Valve (for accessories)
- C Air Line Filter
- D Air Line Moisture Trap and Drain Valve
- L 55 Gallon (200 Liter) Drum

**Model 232200 Shown**

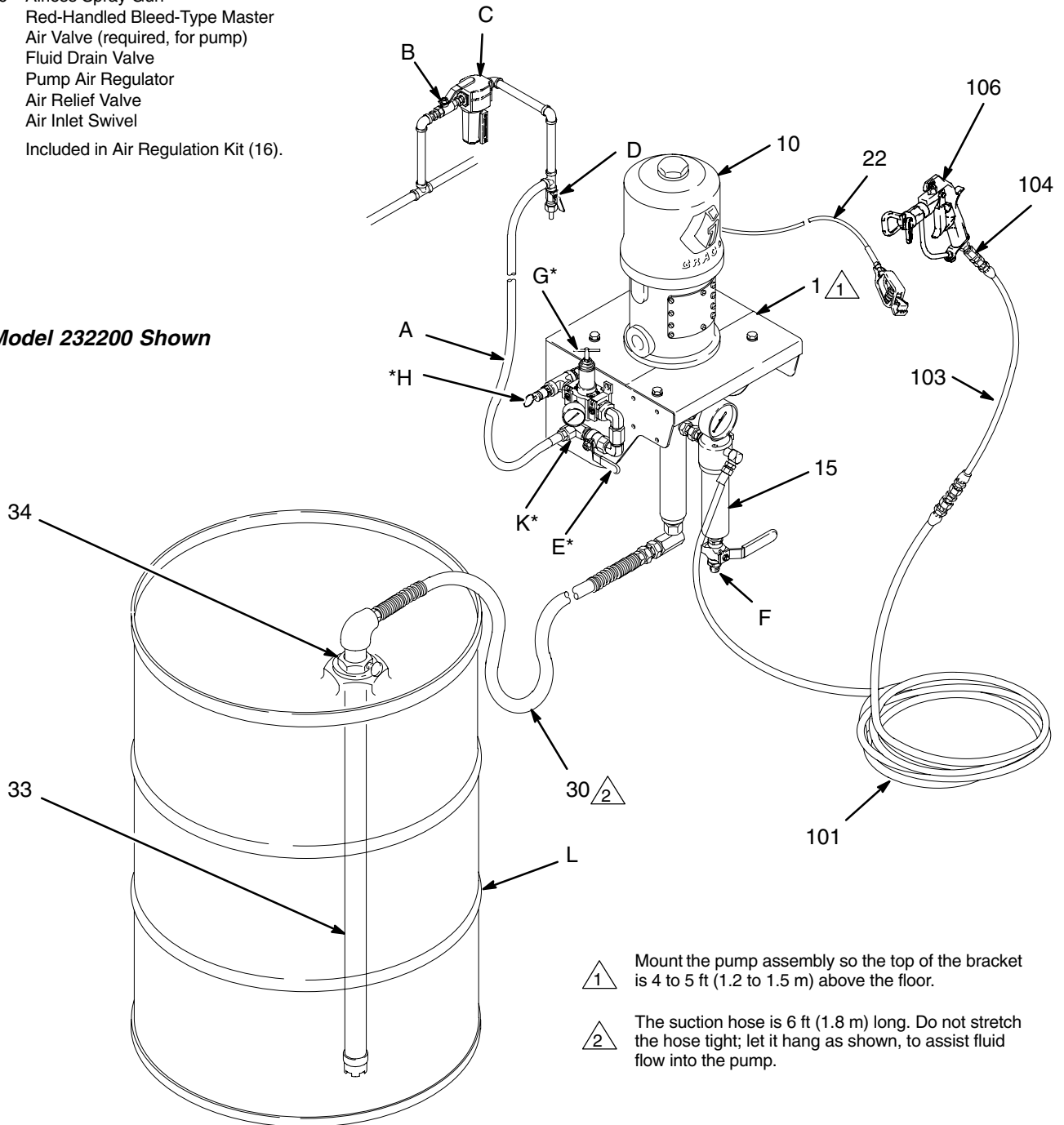

1 Mount the pump assembly so the top of the bracket is 4 to 5 ft (1.2 to 1.5 m) above the floor.

2 The suction hose is 6 ft (1.8 m) long. Do not stretch the hose tight; let it hang as shown, to assist fluid flow into the pump.

**Fig. 1**

# Installation

## Grounding

**⚠ WARNING**

**FIRE AND EXPLOSION HAZARD**  
Before operating the pump, ground the system as explained below. Also read the section **FIRE AND EXPLOSION HAZARD** on page 5.

1. *Pump*: use the ground wire and clamp (supplied). See Fig. 2. Loosen the grounding lug locknut (W) and washer (X). Insert one end of the ground wire (22) into the slot in lug (Z) and tighten the locknut securely. Connect the other end of the wire to a true earth ground.

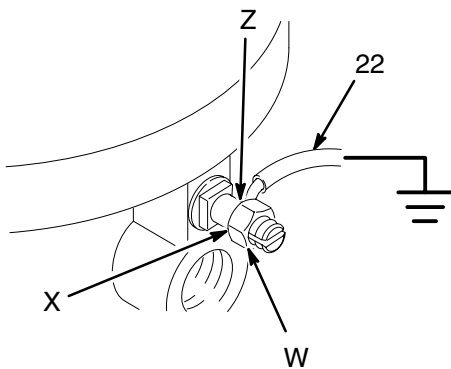

0720

Fig. 2

2. *Air and fluid hoses*: use only electrically conductive hoses.
3. *Air compressor*: follow manufacturer's recommendations.
4. *Spray gun*: ground through connection to a properly grounded fluid hose and pump.
5. *Fluid supply container*: follow your local code.
6. *Object being sprayed*: follow your local code.
7. *Solvent pails used when flushing*: follow your local code. Use only metal pails, which are conductive, placed on a grounded surface. Do not place the pail on a nonconductive surface, such as paper or cardboard, which interrupts the grounding continuity.
8. *To maintain grounding continuity when flushing or relieving pressure*, hold a metal part of the spray gun firmly to the side of a grounded *metal* pail, then trigger the gun.

# Operation

## Pressure Relief Procedure

 **WARNING**

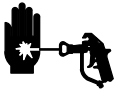

**SKIN INJECTION HAZARD**

The system pressure must be manually relieved to prevent the system from starting or spraying accidentally. Fluid under high pressure can be injected through the skin and cause serious injury. To reduce the risk of an injury from injection, splashing fluid, or moving parts, follow the **Pressure Relief Procedure** whenever you:

- are instructed to relieve the pressure,
- stop spraying,
- check or service any of the system equipment,
- or install or clean the spray tip.

1. Lock the gun trigger safety.
2. Close the red-handled bleed-type master air valve (E, required in your system). See Fig. 3.
3. Unlock the gun trigger safety.
4. Hold a metal part of the gun firmly to the side of a grounded metal pail, and trigger the gun to relieve pressure.
5. Lock the gun trigger safety.
6. Open the drain valve (F, required in your system), having a container ready to catch the drainage.
7. Leave the drain valve open until you are ready to spray again.

*If you suspect that the spray tip or hose is completely clogged, or that pressure has not been fully relieved after following the steps above, **very slowly** loosen the tip guard retaining nut or hose end coupling and relieve pressure gradually, then loosen completely. Now clear the tip or hose.*

## Packing Nut

Before starting, fill the packing nut (M) 1/3 full with Graco Throat Seal Liquid (TSL) or compatible solvent. See Fig. 3.

 **WARNING**

To reduce the risk of serious injury whenever you are instructed to relieve pressure, always follow the **Pressure Relief Procedure** at left.

The packing nut is torqued at the factory and is ready for operation. If it becomes loose and there is leaking from the throat packings, relieve pressure, then torque the nut as specified in your separate pump manual. Do this whenever necessary. Do not overtighten the packing nut.

## Flush the Pump Before First Use

The pump is tested with lightweight oil, which is left in to protect the pump parts. If the fluid you are using may be contaminated by the oil, flush it out with a compatible solvent. See **Flushing** on page 15.

## Prime the Pump

1. See Fig. 3. Remove the tip guard and spray tip from the gun (106). Refer to the gun manual.
2. Close the pump air regulator (G), and bleed-type air valves (B, E).
3. Close the fluid drain valve (F).
4. Connect the air line (A) to the air inlet swivel (K).
5. Check that all fittings throughout the system are tightened securely.
6. Position the drum (L) close to the pump. The suction hose (30) is 6 ft (1.8 m) long. Do not stretch the hose tight; let it hang as shown in Fig. 3, to assist fluid flow into the pump.
7. Place the pump suction tube (33) into the drum. On carbon steel models, screw the bung adapter (34) into the drum's bung hole. Adjust the suction tube so it is about 1/2 in. (13 mm) off the bottom of the drum, then tighten the thumbscrew.

*Continued on page 12.*

# Operation

## Prime the Pump (continued)

8. Hold a metal part of the gun (106) firmly to the side of a grounded metal pail and hold the trigger open.
9. Open the bleed-type air valves (B, E). Slowly open the pump air regulator (G) until the pump starts.
10. Cycle the pump slowly until all air is pushed out and the pump and hoses are fully primed.
11. Release the gun trigger and lock the trigger safety. The pump should stall against pressure.
12. If the pump fails to prime properly, open the drain valve (F). Use the drain valve as a priming valve until the fluid flows from the valve. Close the valve.

**NOTE:** When changing fluid containers with the hose and gun already primed, open the drain valve (F) to help prime the pump and vent air before it enters the hose. Close the drain valve when all air is eliminated.

## Install the Spray Tip

### **WARNING**

To reduce the risk of serious injury whenever you are instructed to relieve pressure, always follow the **Pressure Relief Procedure** on page 11.

Relieve the pressure. Install the spray tip and tip guard as explained in your separate gun manual, supplied.

The spray tip shapes the fluid into a fan pattern. The orifice size determines the flow rate, and the orifice shape determines the width of the fan pattern.

## Adjust the Spray Pattern

1. Start the pump. Use the pump air regulator (G) to adjust the pump speed and fluid pressure until the spray is completely atomized. Use the lowest pressure necessary to get the desired results. Higher pressure may not improve the spray pattern and will cause premature tip and pump wear.

### **WARNING**

#### **COMPONENT RUPTURE HAZARD**



To reduce the risk of overpressurizing your package, which could cause component rupture and serious injury, *never exceed 100 psi (0.7 MPa, 7 bar) air input pressure to the package*. Also refer to the **Technical Data** on page 20 and to your separate component manuals.

2. Use a full-open, full-close triggering action. Hold the gun about 14 in. (350 mm) from and at right angles to the work surface. Move the gun in a straight stroke; do not swing the gun in an arc. Practice to find the best length and speed of stroke.
3. If adjusting the pressure does not give a good spray pattern, relieve the pressure and try another tip size. When more coverage is needed, use a larger spray tip rather than increasing the fluid pressure.
4. With the pump and lines primed, and with adequate air pressure and volume supplied, the pump will start and stop as you open and close the gun.

### **CAUTION**

Do not allow the pump to run dry. It will quickly accelerate to a high speed, causing damage. If your pump is running too fast, stop it immediately and check the fluid supply. If the container is empty and air has been pumped into the lines, refill the container and prime the pump and the lines, or flush and leave it filled with a compatible solvent. Eliminate all air from the fluid system.

## Shutdown and Care of the Pump

### **WARNING**

To reduce the risk of serious injury whenever you are instructed to relieve pressure, always follow the **Pressure Relief Procedure** on page 11.

For overnight shutdown, stop the pump at the bottom of its stroke to prevent fluid from drying on the exposed displacement rod and damaging the throat packings. Relieve the pressure.

Always flush the pump before the fluid dries on the displacement rod. See **Flushing** on page 15.

# Operation

## KEY

- |     |   |   |  |
|-----|---|---|--|
| 15  | Fluid Filter (includes fluid drain valve F)           | B | Bleed-Type Master Air Valve (for accessories)                |
| 30  | Suction Hose  | E | Red-Handled Bleed-Type Master Air Valve (required, for pump) |
| 33  | Suction Tube  | F | Fluid Drain Valve  |
| 34  | Bung Adapter (carbon steel models only)               | G | Pump Air Regulator   |
| 101 | Electrically Conductive Fluid Hose                    | K | Air Inlet Swivel   |
| 103 | Fluid Whip Hose                                       | L | 55 Gallon (200 Liter) Drum                                   |
| 104 | Gun Swivel (includes in-line filter on Monark Models) | M | Packing Nut/Wet-Cup (hidden)                                 |
| 106 | Airless Spray Gun                                     |   |  |
| A   | Electrically Conductive Air Supply Hose               |   |  |

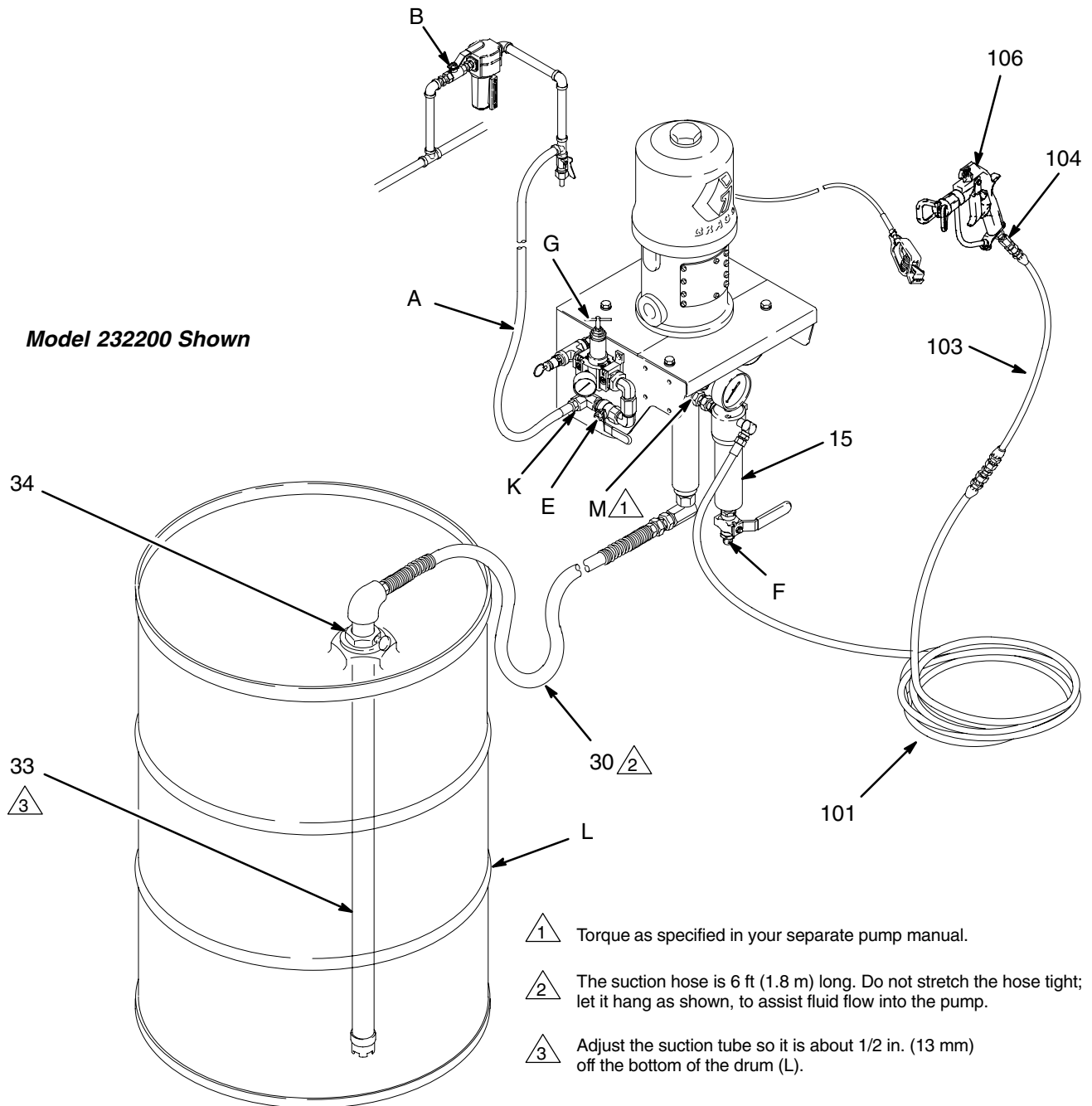

Fig. 3

7780B



# Maintenance

## Preventive Maintenance Schedule

The operating conditions of your particular system determine how often maintenance is required. Establish a preventive maintenance schedule by recording when and what kind of maintenance is needed, and then determine a regular schedule for checking your system.

## Clean the In-Line Fluid Filter Element (Monark models only)

The filter/swivel (104) includes a 100 mesh stainless steel filter element (105). Clean the element periodically with a compatible solvent, as follows.

### WARNING

To reduce the risk of serious injury whenever you are instructed to relieve pressure, always follow the **Pressure Relief Procedure** on page 11.

1. Relieve the pressure.
2. Disassemble the filter/swivel (104) and remove the filter element (105).
3. Clean or replace the element, as necessary.
4. Reassemble. Torque the two halves of the filter/swivel to 10–15 ft-lb (14–20 N•m).

## Flushing

### WARNING



**FIRE AND EXPLOSION HAZARD**  
Before flushing, read the section **FIRE AND EXPLOSION HAZARD** on page 5. Be sure the entire system and flushing pails are properly grounded. Refer to **Grounding** on page 10.

Flush the pump:

- Before the first use
- When changing colors or fluids
- Before fluid can dry or settle out in a dormant pump (check the pot life of catalyzed fluids)
- Before storing the pump.

Flush with a fluid that is compatible with the fluid you are pumping and with the wetted parts in your system. Check with your fluid manufacturer or supplier for recommended flushing fluids and flushing frequency.

### CAUTION

If you have a carbon steel package, never leave water or water-base fluid in the pump overnight. If you are pumping water-base fluid, flush with water first, then with a rust inhibitor such as mineral spirits. Relieve the pressure, but leave the rust inhibitor in the pump to protect the parts from corrosion.

### WARNING

To reduce the risk of serious injury whenever you are instructed to relieve pressure, always follow the **Pressure Relief Procedure** on page 11.

1. Relieve the pressure.
2. Remove the tip guard and spray tip from the gun. Refer to the gun instruction manual.
3. Remove the filter element from the fluid filter (15). Reinstall the filter bowl.
4. Place the suction tube (33) in a container of solvent.
5. Hold a metal part of the gun firmly to the side of a grounded *metal* pail.
6. Start the pump. Always use the lowest possible fluid pressure when flushing.
7. Trigger the gun. Flush the system until clear solvent flows from the gun.
8. Relieve the pressure.
9. Clean the tip guard, spray tip, and fluid filter element separately, then reinstall them.
10. Clean the inside and outside of the suction tube (33).

# Parts

## Model 232200 Shown

1 This style suction tube used on stainless steel models.

2 Included in Suction Tube Kit 206266, used on carbon steel models.

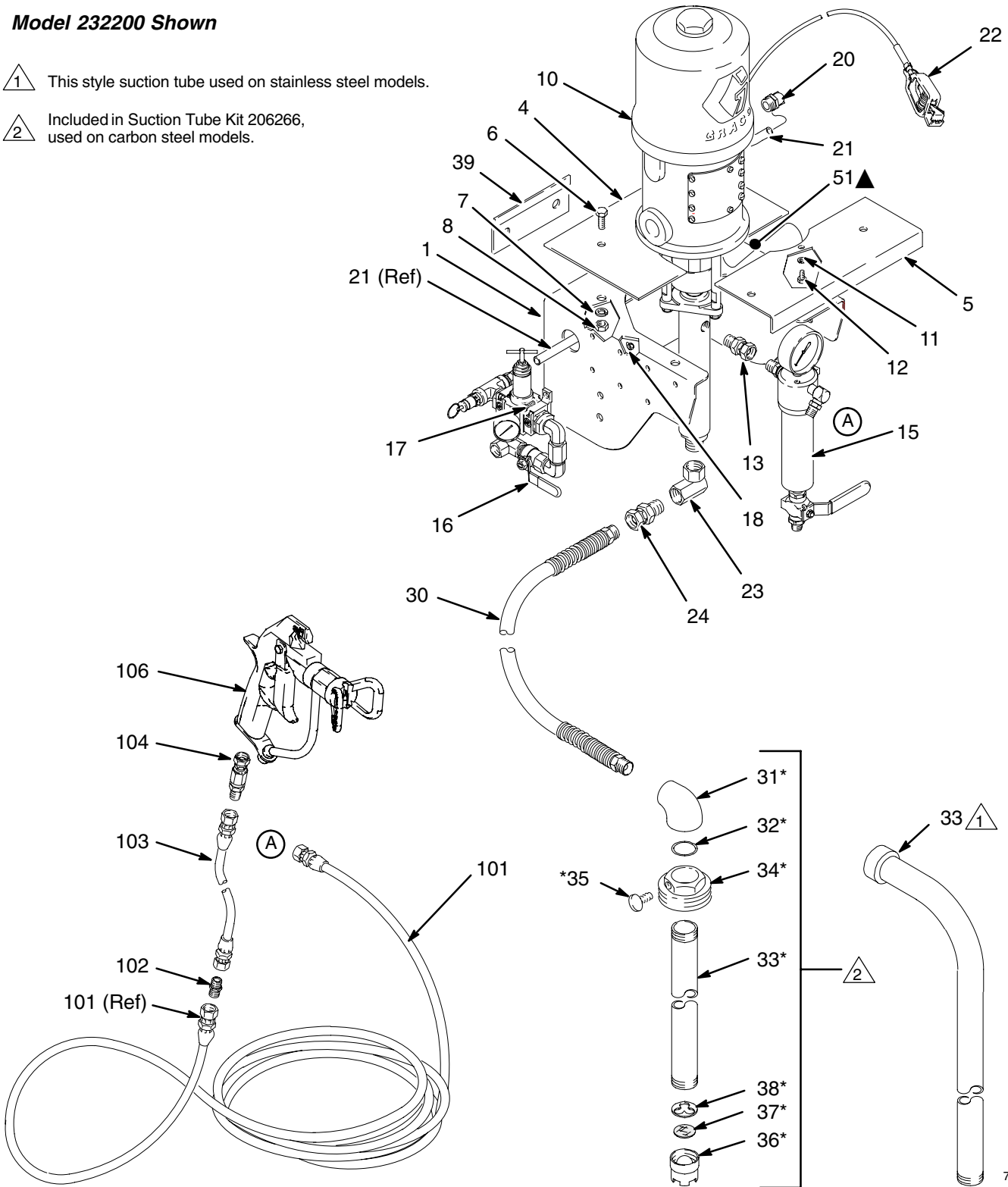



# Parts

**Part No. 232200, Series A, 30:1 President, carbon steel (shown)**

**Part No. 232201, Series A, 30:1 President, carbon steel, without hose and gun**

**Part No. 232211, Series A, 30:1 President, stainless steel**

**Part No. 232212, Series A, 30:1 President, stainless steel, without hose and gun**

**Part No. 232222, Series A, 23:1 Monark, carbon steel**

**Part No. 232223, Series A, 23:1 Monark, carbon steel, without hose and gun**

**Part No. 232233, Series A, 23:1 Monark, stainless steel**

**Part No. 232234, Series A, 23:1 Monark, stainless steel, without hose and gun**

**Part No. 232263, Series A, 46:1 President, carbon steel**

**Part No. 232264, Series A, 46:1 President, carbon steel, without hose and gun**

**NOTE:** Part numbers vary by package. To find the part number used in your package, read down the chart to find the desired ref. no., then read left to right to find the part number for your package.

Ref. No.	Description	Packages					Qty
		CST 232200, 232201	SST 232211, 232212	CST 232222, 232223	SST 232233, 232234	CST 232263, 232264	
1	BRACKET, pump	192584	192584	192584	192584	192584	1
4	ADAPTER, bracket, rear	192768	192768	192768	192768	192768	1
5	ADAPTER, bracket, front	192767	192767	192767	192767	192767	1
6	SCREW, cap, hex hd; 3/8–16 x 3/4 in. (19 mm)	100469	100469	100469	100469	100469	4
7	LOCKWASHER; 3/8 in.	100133	100133	100133	100133	100133	4
8	NUT, hex; 3/8–16	100307	100307	100307	100307	100307	4
9	GROMMET; not shown	114269	114269	114269	114269	114269	1
10	PUMP, 30:1 President; cst; <i>see manual 306981</i>	223586					1
	PUMP, 30:1 President; sst; <i>see manual 308106</i>		223843				1
	PUMP, 23:1 Monark; cst; <i>see manual 307619</i>			223596			1
	PUMP, 23:1 Monark; sst; <i>see manual 307619</i>				237958		1
	PUMP, 46:1 President; cst; <i>see manual 307619</i>					239140	1
11	LOCKWASHER; 1/4 in.	100016	100016	100016	100016	100016	2
12	CAPSCREW, hex hd; 1/4–20 x 5/8 in. (16 mm)	100270	100270			100270	2
	CAPSCREW, hex hd; 1/4–20 x 3/4 in. (19 mm)			100022	100022		2
13	UNION, swivel, straight; cst; 3/8 npt(m) x 3/8 npsm(f)	155665		155665			1
	UNION, swivel, 45°; sst; 3/8 npt(m) x 3/8 npsm(f)		209029		209029		1
	UNION, swivel, 45°; cst; 3/8 npt(m) x 3/8 npsm(f)					161889	1
15	FLUID FILTER; cst; <i>see manual 307273</i>	239964		239964		239964	1
	FLUID FILTER; sst; <i>see manual 307273</i>		239961		239961		1
16	AIR REGULATOR KIT; <i>see manual 308686</i>	239957	239957	239957	239957	239957	1
17	SCREW, socket; M5 x 0.8; 16 mm (5/8 in.)	113768	113768	113768	113768	113768	4
18	NUT, hex, self-locking; M5 x 0.8	105332	105332	105332	105332	105332	4
20	ELBOW, tube fitting, 90°; 1/2 npt(m) x 1/2 in. (13 mm) OD tube	114110	114110			114110	1
	ELBOW, tube fitting, 90°; 3/8 npt(m) x 1/2 in. (13 mm) OD tube			114114	114114		1
21	TUBE; polyurethane; 1/2 in. (13 mm) OD; 1.3 ft (0.4 m) long	Obtain locally	Obtain locally	Obtain locally	Obtain locally	Obtain locally	1
22	GROUND WIRE AND CLAMP	238909	238909	238909	238909	238909	1

# Parts

**Part No. 232200, Series A, 30:1 President, carbon steel (shown)**

**Part No. 232201, Series A, 30:1 President, carbon steel, without hose and gun**

**Part No. 232211, Series A, 30:1 President, stainless steel**

**Part No. 232212, Series A, 30:1 President, stainless steel, without hose and gun**

**Part No. 232222, Series A, 23:1 Monark, carbon steel**

**Part No. 232223, Series A, 23:1 Monark, carbon steel, without hose and gun**

**Part No. 232233, Series A, 23:1 Monark, stainless steel**

**Part No. 232234, Series A, 23:1 Monark, stainless steel, without hose and gun**

**Part No. 232263, Series A, 46:1 President, carbon steel**

**Part No. 232264, Series A, 46:1 President, carbon steel, without hose and gun**

**NOTE:** Part numbers vary by package. To find the part number used in your package, read down the chart to find the desired ref. no., then read left to right to find the part number for your package.

Ref. No.	Description	Packages					Qty
		CST 232200, 232201	SST 232211, 232212	CST 232222, 232223	SST 232233, 232234	CST 232263, 232264	
23	UNION, swivel, 90°; cst; 3/4 npt(f) x 3/4 npsm(f)	156589		156589		156589	1
	UNION, swivel, 90°; sst; 3/4 npt (fbe)		112572		112572		1
24	UNION, swivel; cst; 3/4 npt(m) x 3/4 npsm(f)	157785		157785		157785	1
30	HOSE, suction, nylon; 3/4 npt (mbe) cst fittings; 6 ft (1.8 m) long	214961		214961		214961	1
	HOSE, suction, nylon; 3/4 npt (mbe) sst fittings; 6 ft (1.8 m) long		221171		221171		1
31*	ELBOW, 90°; 3/4 npt x 1 1/2-24 uns-2b (fbe); aluminum	156591		156591		156591	1
32*	O-RING; buna-N	156593		156593		156593	1
33*	TUBE, suction; cst	156592		156592		156592	1
	TUBE, suction; sst		188867		188867		1
34*	ADAPTER, bung	176684		176684		176684	1
35*	THUMBSCREW	100220		100220		100220	1
36*	HOUSING, valve, intake; cst	159101		159101		159101	1
37*	SCREEN, filter; cst	161377		161377		161377	1
38*	STOP, ball; cst	159100		159100		159100	1
39	PLATE, mounting, bracket	192589	192589	192589	192589	192589	1
44	THROAT SEAL LIQUID; 1 pint (0.5 liter); not shown	206994	206994	206994	206994	206994	1
48	NUT, hex; 1/4-20; not shown			100015	100015		2
51▲	LABEL, warning	193145	193145	193145	193145	193145	1

▲ Replacement Danger and Warning labels, tags and cards are available at no cost.

\* These parts are included in Suction Tube Kit 206266, which is used on carbon steel packages only.

# Hose and Gun Parts

**Part No. 232200, Series A, 30:1 President, carbon steel (shown)**

**Part No. 232211, Series A, 30:1 President, stainless steel**

**Part No. 232222, Series A, 23:1 Monark, carbon steel**

**Part No. 232233, Series A, 23:1 Monark, stainless steel**

**Part No. 232263, Series A, 46:1 President, carbon steel**

**NOTE:** The following part numbers apply only to packages supplied with a hose and gun. Part numbers vary by package. To find the part number used in your package, read down the chart to find the desired ref. no., then read left to right to find the part number for your package.

Ref. No.	Description	Packages					Qty
		CST 232200	SST 232211	CST 232222	SST 232233	CST 232263	
101	HOSE, fluid; nylon; cst fluid fittings; 1/4 npsm (fbe); 1/4 in. (6 mm) ID; 25 ft (7.5 m) long	H42525		H42525		H52525	1
	HOSE, fluid; nylon; sst fluid fittings; 1/4 npsm (fbe); 1/4 in. (6 mm) ID; 25 ft (7.5 m) long		239107		239107		1
102	NIPPLE; cst; 1/4 npt x 1/4 npsm	162453		162453		162453	1
	NIPPLE; sst; 1/4 npt x 1/4 npsm		166846		166846		1
103	HOSE, whip, fluid; nylon; cst fittings; 1/4 npsm (fbe); 3/16 in. (5 mm) ID; 23.6 in. (0.6 m) long	238708		238708		239083	1
	HOSE, whip, fluid; nylon; sst fittings; 1/4 npsm (fbe); 3/16 in. (5 mm) ID; 23.6 in. (0.6 m) long		239069		239069		1
104	SWIVEL, gun						1
	FILTER/SWIVEL, gun; includes replaceable item 105						1
105	. ELEMENT, filter; 100 mesh sst; not shown			205264	205264		1
106	AIRLESS SPRAY GUN; XTR504 with HD RAC; <i>see manual 311254</i>	XTR504	XTR504			XTR504	1
	AIRLESS SPRAY GUN, for fine finish; <i>see manual 311254</i>			XTR501	XTR501		1
107	SPRAY TIP, HD RAC; customer's choice						1
	FINE FINISH SPRAY TIP, silver; customer's choice; not shown						1

# Technical Data

Category	Data
Maximum fluid working pressure	<i>Part Nos. 232200, 232201, 232211, 232212:</i> 3000 psi (21 MPa, 210 bar) <i>Part Nos. 232222, 232223, 232233, 232234:</i> 2300 psi (16 MPa, 160 bar) <i>Part Nos. 232263, 232264:</i> 4600 psi (32 MPa, 317 bar)
Maximum air input pressure	100 psi (0.7 MPa, 7 bar)
Ratio	<i>Part Nos. 232200, 232201, 232211, 232212:</i> 30:1 <i>Part Nos. 232222, 232223, 232233, 232234:</i> 23:1 <i>Part Nos. 232263, 232264:</i> 46:1
Maximum operating temperature	120°F (50°C)
Weight	<i>Part Nos. 232200, 232201, 232211, 232212, 232263, 232264:</i> 75 lb (34 kg) <i>Part Nos. 232222, 232223, 232233, 232234:</i> 65 lb (30 kg)
Wetted parts	<i>Pump:</i> See applicable pump manual <i>Spray Gun:</i> See gun manual 311254 <i>Fluid Filter:</i> See filter manual 307273 <i>Fluid Hoses:</i> Nylon

## Sound Pressure Levels (dBa)

(measured at 1 meter from unit)

Air Motor	Input Air Pressures at 15 cycles per minute		
	40 psi (0.28 MPa, 2.8 bar)	70 psi (0.48 MPa, 4.8 bar)	100 psi (0.7 MPa, 7 bar)
President	73.6 dB(A)	78.3 dB(A)	80.9 dB(A)
Monark	73.3 dB(A)	75.9 dB(A)	77.7 dB(A)

## Sound Power Levels (dBa)

(tested in accordance with ISO 9614–2)

Air Motor	Input Air Pressures at 15 cycles per minute		
	40 psi (0.28 MPa, 2.8 bar)	70 psi (0.48 MPa, 4.8 bar)	100 psi (0.7 MPa, 7 bar)
President	87.4 dB(A)	92.1 dB(A)	94.7 dB(A)
Monark	87.0 dB(A)	89.7 dB(A)	91.4 dB(A)

# Technical Data

## Performance Charts

**To find Fluid Outlet Pressure** (psi/MPa/bar) at a specific fluid flow (lpm/gpm) and operating air pressure (psi/MPa/bar):

1. Locate desired flow along bottom of chart.
2. Follow vertical line up to intersection with selected fluid outlet pressure curve (black). Follow left to scale to read fluid outlet pressure.

**KEY:** Fluid Outlet Pressure – Black Curves  
Air Consumption – Gray Curves

**To find Pump Air Consumption** (m<sup>3</sup>/min or scfm) at a specific fluid flow (lpm/gpm) and air pressure (psi/MPa/bar):

1. Locate desired flow along bottom of chart.
2. Read vertical line up to intersection with selected air consumption curve (gray). Follow right to scale to read air consumption.

**A** 100 psi (0.7 MPa, 7 bar) air pressure  
**B** 70 psi (0.49 MPa, 4.9 bar) air pressure  
**C** 40 psi (0.28 MPa, 2.8 bar) air pressure

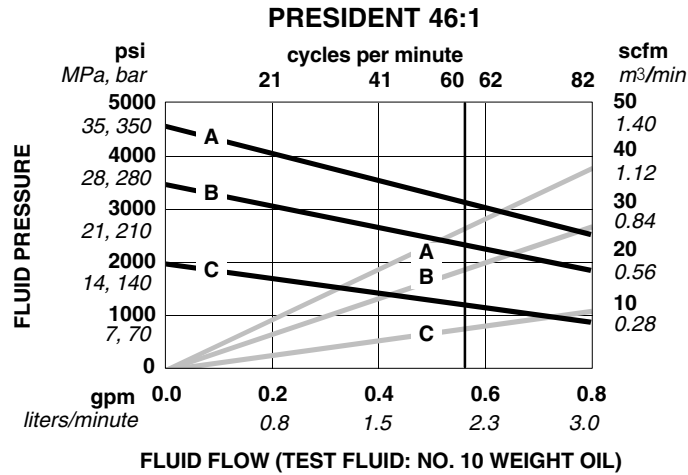
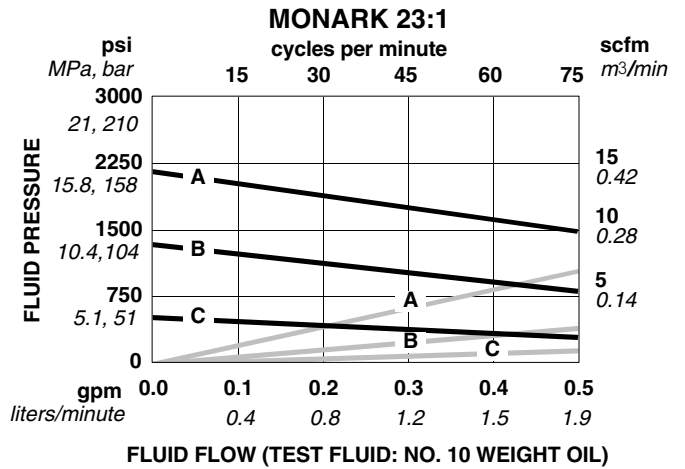
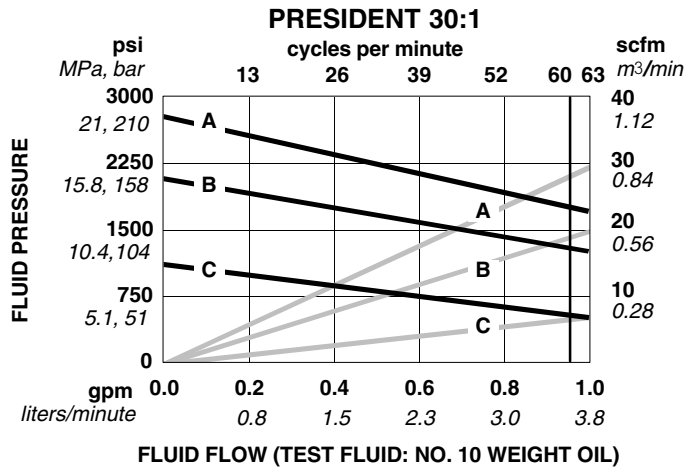

# Dimensions

## Model 232200 Shown

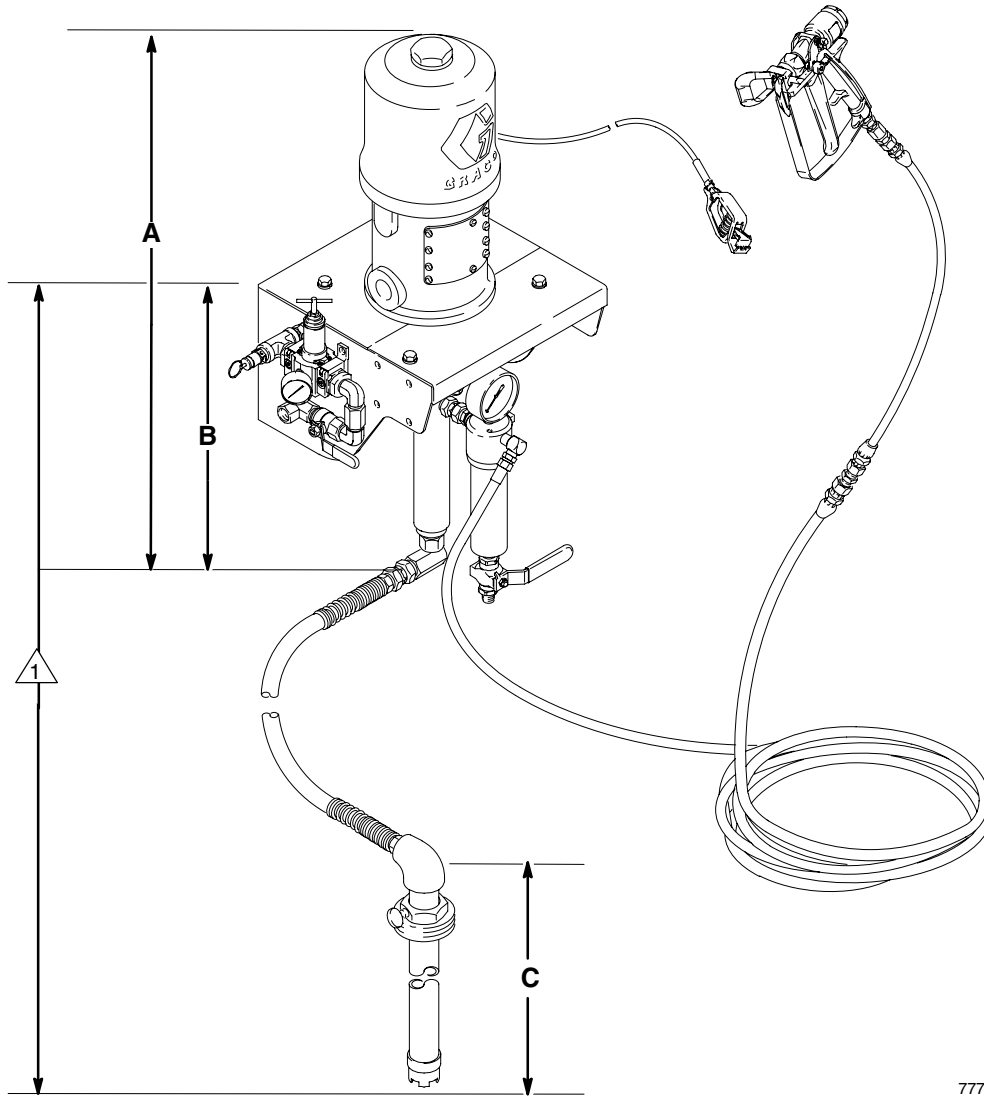

1 Mount the pump assembly so the top of the bracket is 4 to 5 ft (1.2 to 1.5 m) above the floor.



7779B

Pump Model	A	B	C
232200/201 President 30:1 Carbon Steel	32 in. (813 mm)	17 in. (432 mm)	36 in. (914 mm)
232211/212 President 30:1 Stainless Steel	32 in. (813 mm)	17 in. (432 mm)	36 in. (914 mm)
232222/223 Monark 23:1 Carbon Steel	31 in. (787 mm)	16 in. (406 mm)	36 in. (914 mm)
232233/234 Monark 23:1 Stainless Steel	31 in. (787 mm)	16 in. (406 mm)	36 in. (914 mm)
232263/264 President 46:1 Carbon Steel	32 in. (813 mm)	17 in. (432 mm)	36 in. (914 mm)

# Mounting Hole Layout

-  Check that the bracket is level before bolting it to the wall.
-  Mount the pump assembly so the top of the bracket (1) is 4 to 5 ft (1.2 to 1.5 m) above the floor.

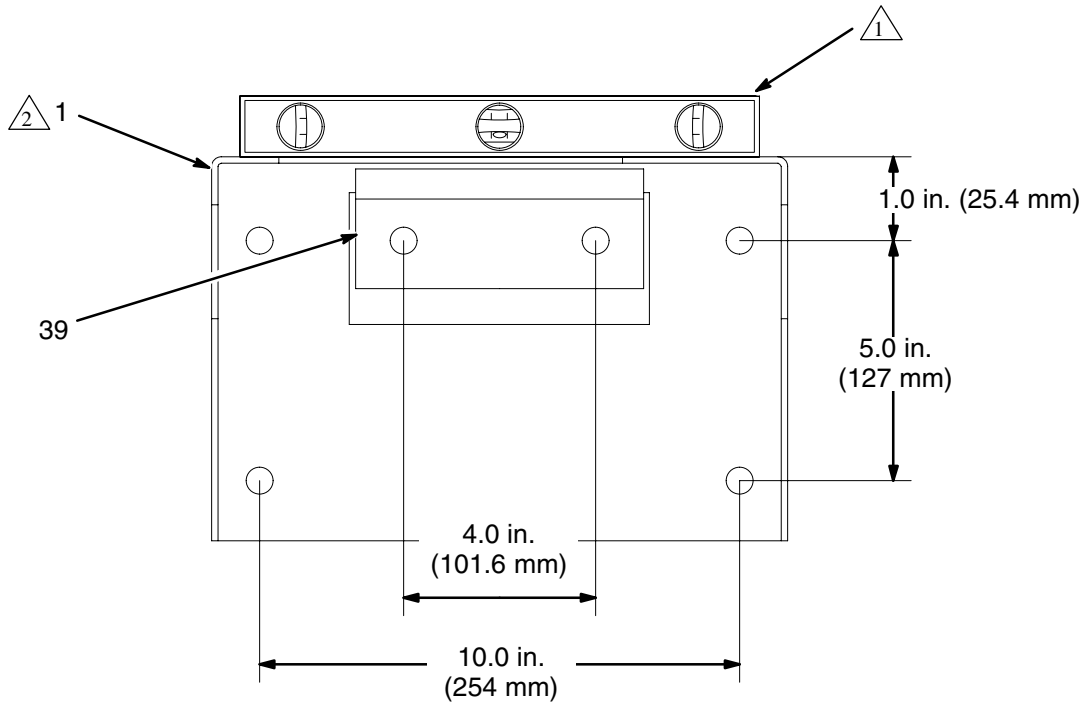

7687A

# Graco Standard Warranty

Graco warrants all equipment manufactured by Graco and bearing its name to be free from defects in material and workmanship on the date of sale to the original purchaser for use. With the exception of any special, extended, or limited warranty published by Graco, Graco will, for a period of twelve months from the date of sale, repair or replace any part of the equipment determined by Graco to be defective. This warranty applies only when the equipment is installed, operated and maintained in accordance with Graco's written recommendations.

This warranty does not cover, and Graco shall not be liable for general wear and tear, or any malfunction, damage or wear caused by faulty installation, misapplication, abrasion, corrosion, inadequate or improper maintenance, negligence, accident, tampering, or substitution of non-Graco component parts. Nor shall Graco be liable for malfunction, damage or wear caused by the incompatibility of Graco equipment with structures, accessories, equipment or materials not supplied by Graco, or the improper design, manufacture, installation, operation or maintenance of structures, accessories, equipment or materials not supplied by Graco.

This warranty is conditioned upon the prepaid return of the equipment claimed to be defective to an authorized Graco distributor for verification of the claimed defect. If the claimed defect is verified, Graco will repair or replace free of charge any defective parts. The equipment will be returned to the original purchaser transportation prepaid. If inspection of the equipment does not disclose any defect in material or workmanship, repairs will be made at a reasonable charge, which charges may include the costs of parts, labor, and transportation.

**THIS WARRANTY IS EXCLUSIVE, AND IS IN LIEU OF ANY OTHER WARRANTIES, EXPRESS OR IMPLIED, INCLUDING BUT NOT LIMITED TO WARRANTY OF MERCHANTABILITY OR WARRANTY OF FITNESS FOR A PARTICULAR PURPOSE.**

Graco's sole obligation and buyer's sole remedy for any breach of warranty shall be as set forth above. The buyer agrees that no other remedy (including, but not limited to, incidental or consequential damages for lost profits, lost sales, injury to person or property, or any other incidental or consequential loss) shall be available. Any action for breach of warranty must be brought within two (2) years of the date of sale.

Graco makes no warranty, and disclaims all implied warranties of merchantability and fitness for a particular purpose in connection with accessories, equipment, materials or components sold but not manufactured by Graco. These items sold, but not manufactured by Graco (such as electric motors, switches, hose, etc.), are subject to the warranty, if any, of their manufacturer. Graco will provide purchaser with reasonable assistance in making any claim for breach of these warranties.

In no event will Graco be liable for indirect, incidental, special or consequential damages resulting from Graco supplying equipment hereunder, or the furnishing, performance, or use of any products or other goods sold hereto, whether due to a breach of contract, breach of warranty, the negligence of Graco, or otherwise.

## **FOR GRACO CANADA CUSTOMERS**

The parties acknowledge that they have required that the present document, as well as all documents, notices and legal proceedings entered into, given or instituted pursuant hereto or relating directly or indirectly hereto, be drawn up in English. Les parties reconnaissent avoir convenu que la rédaction du présente document sera en Anglais, ainsi que tous documents, avis et procédures judiciaires exécutés, donnés ou intentés à la suite de ou en rapport, directement ou indirectement, avec les procédures concernées.

# Graco Information

**TO PLACE AN ORDER**, contact your Graco distributor, or call one of the following numbers to identify the distributor closest to you:

**1-800-328-0211 Toll Free**

**612-623-6921**

**612-378-3505 Fax**

*All written and visual data contained in this document reflects the latest product information available at the time of publication.*

*Graco reserves the right to make changes at any time without notice.*

This manual contains English. MM 308756

**Graco Headquarters:** Minneapolis  
**International Offices:** Belgium, China, Japan, Korea

**www.graco.com**

12/1997, Revised 5/2007