



This manual contains important warnings and information.  
**READ AND KEEP FOR REFERENCE.**

INSTRUCTIONS

First choice when quality counts.™

230 VAC

## ULTRA® MAX 1595 AIRLESS PAINT SPRAYER

210 bar ( 21 MPa, 3000 psi ) Maximum Working Pressure

### Model 232-164 Series A

Complete sprayer on Upright cart with hose, gun, RAC IV™ DripLess™ Tip Guard and SwitchTip™

U.S. PATENT NO. 4,323,741; 4,397,610  
PATENTED 1983, CANADA  
AND OTHER PATENTS PENDING

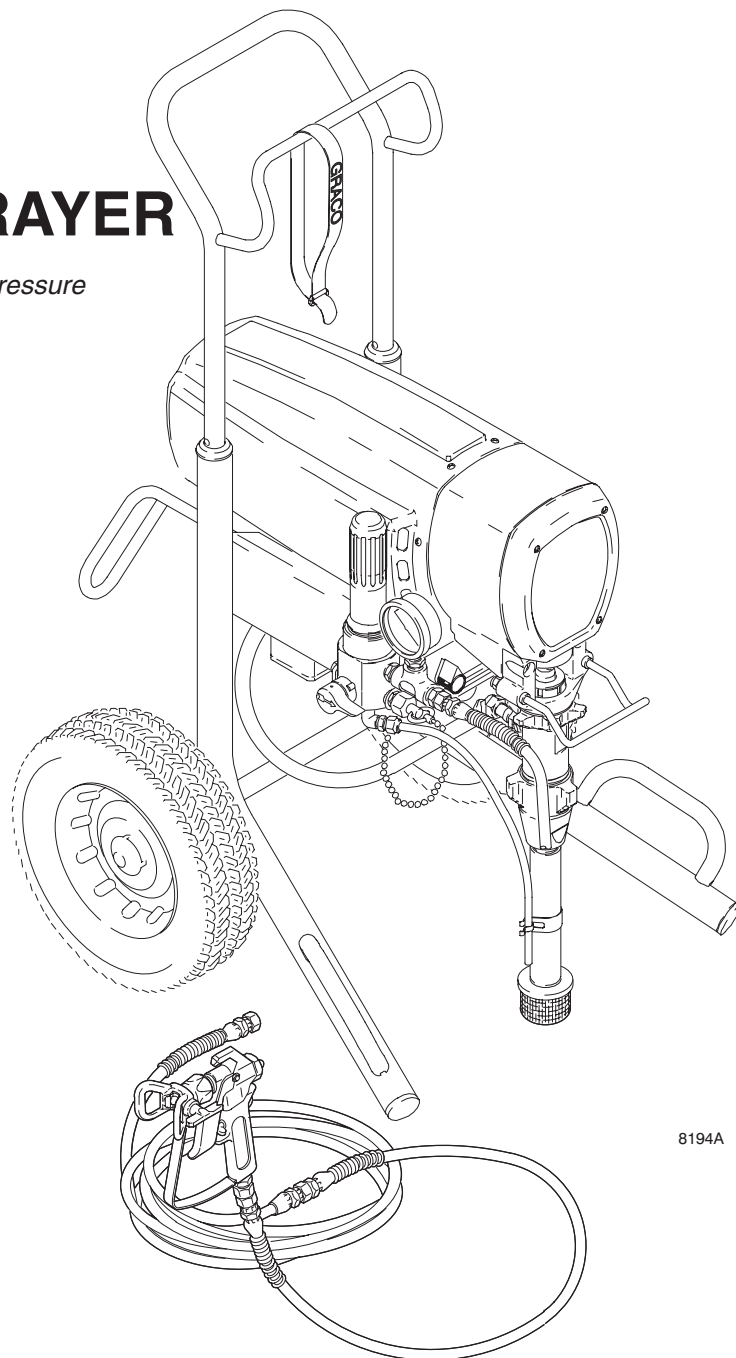

8194A



### Related Manuals

Displacement Pump ..... 308-798  
Spray Gun ..... 307-614  
Spray Tip ..... 308-644

MODEL 232-164

GRACO INC. P.O. BOX 1441 MINNEAPOLIS, MN 55440-1441

©COPYRIGHT 1998, GRACO INC.

Graco Inc. is registered to I.S. EN ISO 9001

# Table of Contents

Warnings . . . . .	2	Motor Replacement . . . . .	21
Component Function and Identification . . . . .	5	Bearing Housing & Connecting Rod Replacement . . . . .	23
Setup . . . . .	6	Drive Housing Replacement . . . . .	24
Startup . . . . .	8	Displacement Pump Repair . . . . .	25
Shutdown and Care . . . . .	10	Accessories . . . . .	27
Flushing . . . . .	11	Technical Data . . . . .	27
Troubleshooting . . . . .	12	Dimensions . . . . .	27
General Repair Information . . . . .	14	Parts Drawing . . . . .	28
Motor Brush Replacement . . . . .	15	Parts List . . . . .	29
Pressure Control . . . . .	17	Graco Phone Number . . . . .	32
Pressure Control Repair . . . . .	18	Graco Warranty . . . . .	32
Pressure Control Wiring . . . . .	20		

## Symbols

### Warning Symbol



This symbol alerts you to the possibility of serious injury or death if you do not follow the instructions.

### Caution Symbol



This symbol alerts you to the possibility of damage to or destruction of equipment if you do not follow the instructions.

## WARNING



INSTRUCTIONS

### EQUIPMENT MISUSE HAZARD

Equipment misuse can cause the equipment to rupture or malfunction and result in serious injury.

- This equipment is for professional use only.
- Read all instruction manuals, tags, and labels before operating the equipment.
- Use the equipment only for its intended purpose. If you are not sure, call your Graco distributor.
- Do not alter or modify this equipment. Use only genuine Graco parts.
- Check equipment daily. Repair or replace worn or damaged parts immediately.
- Do not exceed the maximum working pressure of the lowest rated system component. Refer to the **Technical Data** on page 27 for the maximum working pressure of this equipment.
- Use fluids and solvents which are compatible with the equipment wetted parts. Refer to the **Technical Data** section of all equipment manuals. Read the fluid and solvent manufacturer's warnings.
- Do not use 1,1,1-trichloroethane, methylene chloride, other halogenated hydrocarbon solvents or fluids containing such solvents in pressurized aluminum equipment. Such use could result in a chemical reaction, with the possibility of explosion.
- Do not use hoses to pull equipment.
- Route hoses away from traffic areas, sharp edges, moving parts, and hot surfaces. Do not expose Graco hoses to temperatures above 82°C (180°F) or below -40°C (-40°F).
- Do not lift pressurized equipment.
- Comply with all applicable local, state, and national fire, electrical, and safety regulations.

# WARNING



## INJECTION HAZARD

Spray from the gun, leaks or ruptured components can inject fluid into your body and cause extremely serious injury, including the need for amputation. Fluid splashed in the eyes or on the skin can also cause serious injury.

- Fluid injected into the skin is a serious injury. The injury may look like just a cut, but it is a serious injury. Get immediate medical attention.
- Do not point the gun at anyone or at any part of the body.
- Do not put your hand or fingers over the spray tip.
- Do not stop or deflect leaks with your hand, body, glove or rag.
- Do not “blow back” fluid; this is not an air spray system.
- Always have the tip guard and the trigger guard on the gun when spraying.
- Check the gun diffuser operation weekly. Refer to the gun manual.
- Be sure the gun trigger safety operates before spraying.
- Lock the gun trigger safety when you stop spraying.
- Follow the **Pressure Relief Procedure** on page 8 if the spray tip clogs and before cleaning, checking or servicing the equipment.
- Tighten all fluid connections before operating the equipment.
- Check the hoses, tubes, and couplings daily. Replace worn or damaged parts immediately. Do not repair high pressure couplings; you must replace the entire hose.
- Fluid hoses must have spring guards on both ends, to help protect them from rupture caused by kinks or bends near the couplings.



## TOXIC FLUID HAZARD

Hazardous fluid or toxic fumes can cause serious injury or death if splashed in the eyes or on the skin, inhaled, or swallowed.

- Know the specific hazards of the fluid you are using.
- Store hazardous fluid in an approved container. Dispose of hazardous fluid according to all local, state and national guidelines.
- Always wear protective eyewear, gloves, clothing and respirator as recommended by the fluid and solvent manufacturer.

# ! WARNING



## FIRE AND EXPLOSION HAZARD

Improper grounding, poor ventilation, open flames or sparks can cause a hazardous condition and result in a fire or explosion and serious injury.

- If there is any static sparking or you feel an electric shock while using this equipment, **stop spraying immediately**. Do not use the equipment until you identify and correct the problem.
- Provide fresh air ventilation to avoid the buildup of flammable fumes from solvents or the fluid being sprayed.
- Keep the spray area free of debris, including solvent, rags, and gasoline.
- Electrically disconnect all equipment in the spray area.
- Extinguish all open flames or pilot lights in the spray area.
- Do not smoke in the spray area.
- Do not turn on or off any light switch in the spray area while operating or if fumes are present.
- Do not operate a gasoline engine in the spray area.
- Use only with a grounded outlet that matches the grounded plug of this equipment.



## MOVING PARTS HAZARD

Moving parts can pinch or amputate your fingers.

- Keep clear of all moving parts when starting or operating the pump.
- Before servicing the equipment, follow the **Pressure Relief Procedure** on page 8 to prevent the equipment from starting unexpectedly.

**NOTE:** This is an example of the DANGER label on your sprayer. This label is available in other languages, free of charge. See page 27 to order.

! <b>DANGER</b> !			
	<b>FIRE AND EXPLOSION HAZARD</b>		<b>SKIN INJECTION HAZARD</b>
<p>Spray painting, flushing or cleaning equipment with flammable liquids in confined areas can result in fire or explosion.</p> <p>Use outdoors or in extremely well ventilated areas. Ground equipment, hoses, containers and objects being sprayed.</p> <p>Avoid all ignition sources such as static electricity from plastic drop cloths, open flames such as pilot lights, hot objects such as cigarettes, arcs from connecting or disconnecting power cords or turning light switches on and off.</p> <p>Failure to follow this warning can result in death or serious injury</p>	<p>Liquids can be injected into the body by high pressure airless spray or leaks – especially hose leaks.</p> <p>Keep body clear of the nozzle. Never stop leaks with any part of the body. Drain all pressure before removing parts. Avoid accidental triggering of gun by always setting safety latch when not spraying.</p> <p>Never spray without a tip guard.</p> <p>In case of accidental skin injection, seek immediate “Surgical Treatment”.</p> <p>Failure to follow this warning can result in amputation or serious injury.</p>	<p><b>READ AND UNDERSTAND ALL LABELS AND INSTRUCTION MANUALS BEFORE USE</b></p>	

# Component Identification and Function

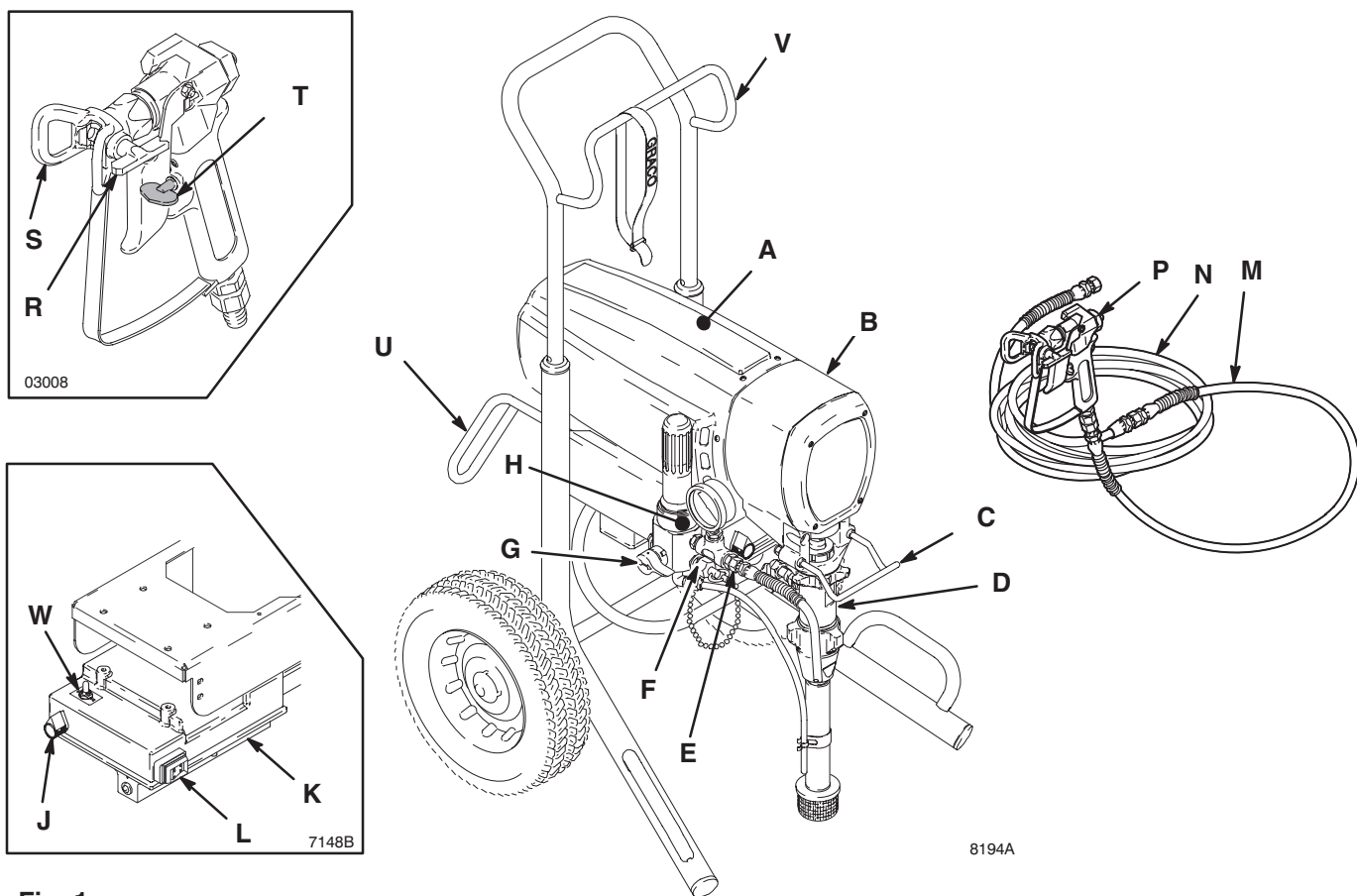

Fig. 1

<b>A</b>	Motor	DC motor, permanent magnet, totally enclosed, fan cooled
<b>B</b>	Drive Assembly	Transfers power from DC motor to the displacement pump
<b>C</b>	Pail Hanger	Container for fluid to be sprayed may be hung here
<b>D</b>	Displacement Pump	Transfers fluid to be sprayed from source through spray gun
<b>E</b>	Primary Fluid Outlet	Single spray gun operation is connected here
<b>F</b>	Secondary Fluid Outlet	Second spray gun operation is connected here
<b>G</b>	Pressure Drain Valve	Relieves fluid outlet pressure when open
<b>H</b>	Fluid Filter	Final filter of fluid between source and spray gun
<b>J</b>	Pressure Adjusting Knob	Controls fluid outlet pressure
<b>K</b>	Pressure Control	Controls motor speed to maintain fluid outlet pressure at displacement pump outlet. Works with pressure adjusting knob.
<b>L</b>	ON/OFF Switch	Power switch that controls 230 VAC main power to sprayer
<b>M</b>	3 ft (0.9 m) Hose	3/16 in. ID, grounded, nylon hose used between 50 ft hose and spray gun to allow more flexibility when spraying
<b>N</b>	50 ft (15 m) Main Hose	1/4 in. ID, grounded, nylon hose with spring guards on both ends
<b>P</b>	Contractor Gun	High pressure spray gun with gun safety latch
<b>R</b>	RAC IV Switch Tip	Uses high pressure fluid to clear tip clogs without removing tip from spray gun
<b>S</b>	RAC IV Tip Guard	Reverse-A-Clean (RAC) tip guard reduces the risk of injection injury
<b>T</b>	Spray Gun Safety Latch	Gun safety latch inhibits accidental triggering of spray gun
<b>U</b>	Power Cord Rack	Holds wrapped power cord for storage
<b>V</b>	Spray Hose Rack	Holds wrapped spray hose for storage
<b>W</b>	10/12 Amp Switch	Allows sprayer to operate on 10A service with reduced performance

# Setup

## ⚠ WARNING

If you supply your own hoses and spray gun, be sure the hoses are electrically conductive, that the gun has a tip guard, and that each part is rated for at least *3000 psi (210 bar, 21 MPa) Working Pressure*. This is to reduce the risk of serious injury caused by static sparking, fluid injection or over-pressurization and rupture of the hose or gun.

## ⚠ CAUTION

To avoid damaging the pressure control, which may result in poor equipment performance and component damage, follow these precautions:

- Do not allow material to freeze in sprayer.
- Use nylon spray hose at least 50 ft (15 m) long.
- Do not use wire braid hose.
- Do not install shutoff device between sprayer and gun. See Fig. 1.

**NOTE:** See Fig. 1, except where noted.

1. Fill packing nut full with Graco Throat Seal Liquid (TSL), supplied. Fig. 2.

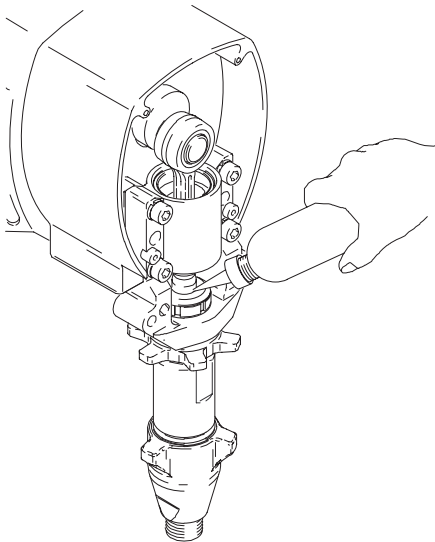

7677A

Fig. 2

2. Single gun hookup.

Use 1/4 in. ID, 50 ft (minimum) main hose. For more flexible gun movement, install 3/16 in. ID, 3 ft hose between main hose and gun.

- a. Connect gun, 3 ft hose and 50 ft hose.
- b. Connect gun and hose assembly to primary fluid outlet (E). Do not use thread sealant.
- c. Do not install spray tip.

3. Two gun hookup.

Use 1/4 in. ID, 50 ft (minimum) main hose. For more flexible gun movement, install 3/16 in. ID, 3 ft hose between main hose and gun.

- a. Connect gun, 3 ft hose and 50 ft hose.
- b. Unscrew cap from 1/4 npsm(m) secondary fluid outlet (F).
- c. Connect gun and hose assembly to secondary fluid outlet.

## ⚠ WARNING



### FIRE AND EXPLOSION HAZARD

Proper electrical grounding is essential to reduce the risk of fire or explosion which can result in serious injury and property damage. Also read **FIRE OR EXPLOSION HAZARD** on page 4 and **Grounding**, page 7.



4. Turn ON/OFF (L) switch OFF. Plug sprayer power cord into grounded electrical outlet at least 20 ft (6 m) from spray area.
5. Flush pump to remove oil. See **Flushing**, page 11.
6. Prepare paint according to manufacturer's recommendations. Remove any paint skin. Stir paint thoroughly. Strain paint through fine nylon mesh bag (available at most paint dealers) to remove particles that could clog filter or spray tip. This is an important step for trouble-free paint spraying.

# Setup

## Grounding

### **WARNING**

Improper installation or alteration of the grounding plug will result in a risk of electric shock, fire or explosion that could cause serious injury or death.

### 230 Vac Systems

1. This equipment requires a 230 Vac, 50 Hz, 10A circuit with a grounding receptacle. See Fig. 3.
2. A 1.5 mm<sup>2</sup> by 90 m extension cord may be used with this equipment.

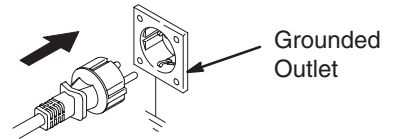

**Fig. 3**

---

# Startup

## WARNING



### INJECTION HAZARD

The system pressure must be manually relieved to prevent the system from starting or spraying accidentally. Fluid under high pressure can be injected through the skin and cause serious injury. To reduce the risk of an injury from injection, splashing fluid, or moving parts, follow the **Pressure Relief Procedure** whenever you:

- are instructed to relieve the pressure,
- stop spraying,
- check or service any of the system equipment,
- or install or clean the spray tip.

## Startup Procedure

**NOTE:** Flush sprayer if first-time startup. See page 11.

**NOTE:** See Fig. 4 except where noted.

1. Close pressure drain valve (G).
2. Don't install spray tip until pump is primed!
3. Put suction tube (M) into paint container.
4. Turn pressure adjusting knob (J) fully counter-clockwise to zero pressure.
5. Plug in sprayer power cord.

## CAUTION

Do not run pump without fluid in it for more than 30 seconds to avoid damaging pump packings.

## Pressure Relief Procedure

1. Engage gun safety latch.
2. Turn ON/OFF switch to OFF.
3. Unplug power supply cord.
4. Disengage gun safety latch. Hold metal part of gun firmly to grounded metal pail. Trigger gun to relieve pressure.
5. Engage gun safety latch.
6. Open pressure drain valve. Leave pressure drain valve open until ready to spray again.

*If you suspect that the spray tip or hose is completely clogged, or that pressure has not been fully relieved after following the steps above, VERY SLOWLY loosen tip guard retaining nut or hose end coupling to relieve pressure gradually, then loosen completely. Now clear tip or hose obstruction.*

Use this procedure each time you start sprayer to ensure sprayer is ready to operate safely.

## WARNING



### FIRE AND EXPLOSION HAZARD

To reduce risk of static sparking and splashing when priming or flushing system, hold metal part of gun firmly to side of grounded metal pail before triggering gun.

6. Prime pump.
  - a. Open (handle down) pressure drain valve (G). If no secondary hose is installed, be sure secondary outlet cap is installed. Turn ON/OFF (L) switch ON. Slowly turn pressure adjusting knob clockwise until sprayer starts. When fluid comes from drain hose, close pressure drain valve (handle forward).
  - b. Fig. 5. Disengage gun safety latch. Following warning, above, trigger gun until all air is forced out of system and paint flows freely from gun.
  - c. Release trigger. Engage gun safety latch.
7. Check all fluid connections for leaks. Relieve fluid pressure before tightening connections.
8. Fig. 5. Engage gun safety latch. Install spray tip. Install tip guard. See manual 308–644, supplied.



# Startup

## 9. Adjust spray pattern.

- Increase pressure just until spray from gun is completely atomized. Use lowest pressure necessary to get desired results. This reduces overspray and fogging, decreases tip wear and extends the life of the sprayer.
- For more coverage, use larger tip rather than increasing pressure.
- Test spray pattern. To adjust pattern, engage gun safety latch, loosen retaining nut. Position tip guard horizontally for horizontal pattern or vertically for vertical pattern. Then tighten retaining nut. Fig. 5.

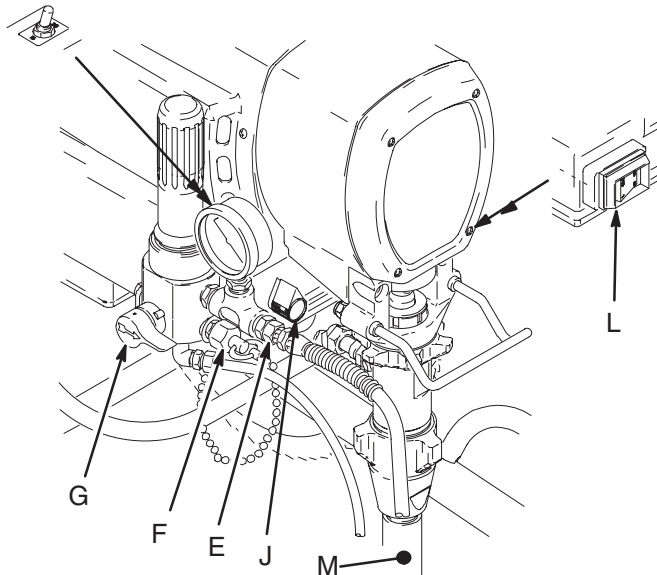

Fig. 4

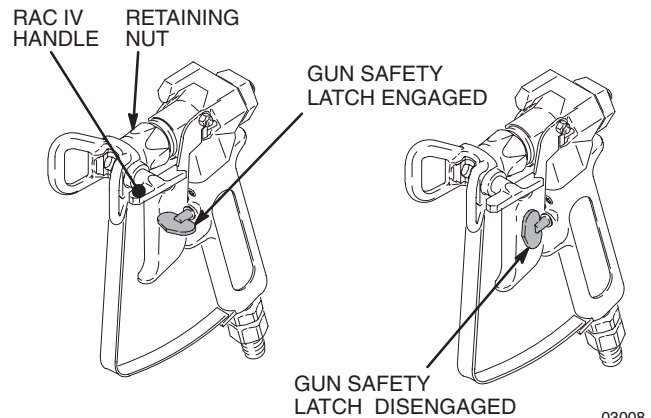

Fig. 5

03008

## Cleaning a Clogged Tip

### ⚠ WARNING



#### INJECTION HAZARD

To reduce the risk of serious injury, whenever you are instructed to relieve pressure, follow the **Pressure Relief Procedure** on page 8.

#### Procedure on page 8.

- Relieve pressure.
- Clean front of tip frequently during operation.
- If spray tip clogs, release gun trigger, engage gun safety latch, and rotate RAC IV handle 180°. See Fig. 5.
- Disengage gun safety latch and trigger gun into waste container. Engage gun safety latch again.
- Rotate RAC IV handle 180° to original position, disengage gun safety latch, and resume spraying.
- If tip is still clogged, engage gun safety latch, shut off and unplug the sprayer, and open pressure drain valve to relieve pressure. Clean spray tip as shown in manual 308–644.

# Shutdown and Care

## **⚠ WARNING**



### **INJECTION HAZARD**

To reduce the risk of serious injury, whenever you are instructed to relieve pressure, follow the **Pressure Relief Procedure** on page 8.

**Procedure** on page 8.

1. Check packing nut (A) daily. First relieve pressure. Keep packing nut full of TSL at all times to help prevent fluid buildup on piston rod and premature wear of packings. See Fig. 6.

If pump begins to leak, loosen packing nut and remove throat nut spacer (B). Tighten packing nut just snug. Over tightening causes binding and excessive packing wear. Use a round punch or brass rod and light hammer to adjust nut. When leakage occurs again, repack the pump.

2. Clean fluid filter often and whenever sprayer is stored. Follow Flushing Guidelines on page 11 for cleaning procedure.
3. Lubricate bearing housing after every 100 hours of operation. First relieve pressure. Remove front cover (C). Fill bearing housing cavity (D) with SAE 10 non-detergent oil. See Fig. 7.
4. For very short shutoff periods, leave suction tube in paint, relieve pressure, and clean spray tip.
5. Flush sprayer at end of each work day and fill it with mineral spirits to help prevent pump corrosion and freezing. See page 11.

## **⚠ CAUTION**

To prevent pump corrosion, never leave water or any type of paint in the sprayer when it is not in use. Pump water or paint out with mineral spirits.

6. Coil hose and hang it on hose rack when storing it, even for overnight, to help protect hose from kinking, abrasion, coupling damage, etc.

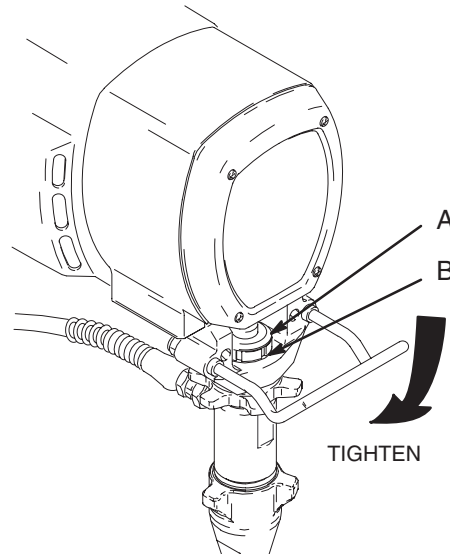

Fig. 6

7692A

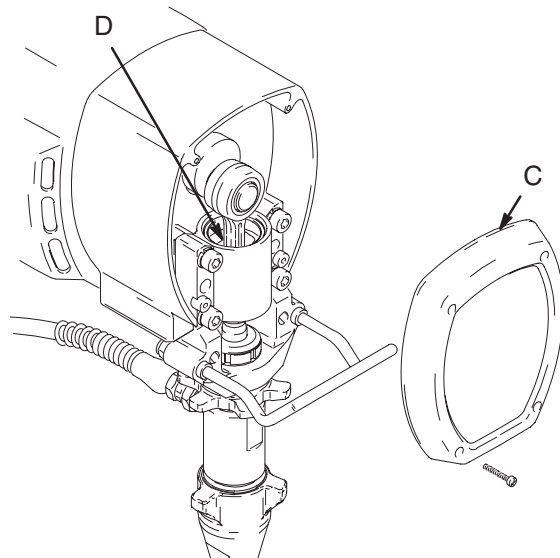

Fig. 7

7693A

# Flushing

## When to flush

Determine material to spray from column 1. Flush with material in column 2. Then follow recommendations in one of next three columns.

<b>⚠ CAUTION</b>
Do not leave water or water-based fluids in sprayer if it could freeze. Push water out with mineral spirits. Frozen fluid in sprayer prevents starting and may cause serious damage.

If you are going to: ▼	Flush with: ▼	Prime with: ▼	Clean with: ▼	Store unit with: ▼
Spray with new sprayer or sprayer that has been stored	Mineral spirits, then compatible solvent such as water or mineral spirits	Compatible paint, such as latex or oil-base	Compatible solvent such as water or mineral spirits	Mineral spirits
Spray latex paint	Warm, soapy water, then clean water	Latex paint	Warm soapy water, then clean water	Mineral spirits
Spray oil paint	Mineral spirits	Oil-base paint	Mineral spirits	Mineral spirits
Change latex to oil paint	Warm, soapy water, then clean water	Mineral spirits	Mineral spirits	Mineral spirits
Change oil to latex paint	Mineral spirits, then soapy water, and finally, clean water	Latex	Warm, soapy water, then clean water	Mineral spirits
Change colors, same base	Compatible solvent such as water or mineral spirits			

## How to flush

**⚠ WARNING**



**FIRE AND EXPLOSION HAZARD**  
To reduce static sparking and splashing, always remove the spray tip from the gun, and hold a metal part of the gun firmly to the side of a grounded metal pail when flushing.

- Follow **Pressure Relief Procedure** on page 8. Engage gun safety latch. See Fig. 8.
- Turn pressure adjusting knob (J) fully counter-clockwise to zero pressure.
- Remove spray tip from gun. Remove filter bowl, filter support and screen. Clean screen separately and install bowl without screen or support to flush it.
- Put suction tube into a grounded metal pail with 2 liters of compatible solvent. Close pressure drain valve (G).
- Start sprayer. See page 8. To save fluid still in sprayer, trigger gun into another container until next fluid appears, then trigger gun back into fluid compatible solvent container. Circulate flushing fluid a few minutes to thoroughly clean system.
- Do not run pump dry for more than 30 seconds to avoid damaging pump packings!
- Follow **Pressure Relief Procedure** on page 8. Engage gun safety latch.
- Unscrew filter bowl and reinstall clean screen. Install bowl and hand tighten.
- Remove suction tube and screen and clean them separately.

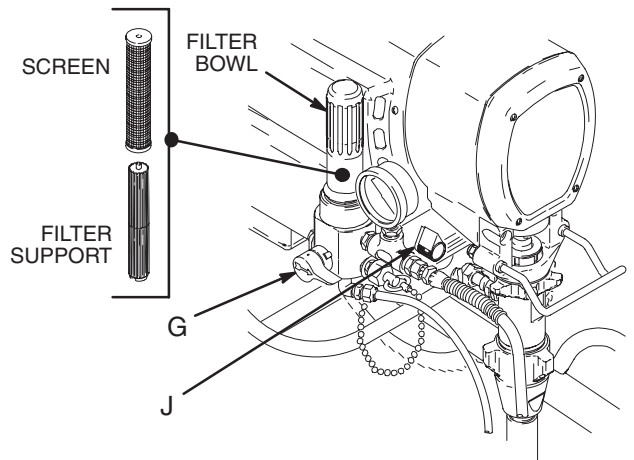

Fig. 8

8183A

# Troubleshooting

## WARNING



### INJECTION HAZARD

To reduce the risk of serious injury, whenever you are instructed to relieve pressure, follow the **Pressure Relief Procedure** on page 8.

Check everything in the guide before disassembling the sprayer.

TYPE OF PROBLEM	WHAT TO CHECK <i>If check is OK, go to next check</i>	WHAT TO DO <i>When check is not OK refer to this column</i>
Building circuit breaker opens	Check all electrical wiring for damaged insulation.	Replace any damaged wiring.
	Check for other electrical appliances on circuit.	Shutdown other electrical appliances on circuit.
	Check position of 10–12 (LO–HIGH) amp switch.	Put switch in 10 amp (LO) position.
Sprayer will not run	Check pressure control knob setting. Motor will not run if it is at minimum setting (fully counterclockwise).	Slowly increase pressure setting to see if motor starts.
	Check for a clogged spray tip. Refer to separate gun or tip instruction manual.	Relieve pressure. Refer to separate gun or tip instruction manual for tip cleaning.
	Check extension cord for visible damage. Use a volt meter or test lamp at extension cord outlet to check.	Replace extension cord.
	Check sprayer power supply cord for visible damage such as broken insulation or wires.	Replace power supply cord.
	Check electrical supply with volt meter. Meter must read 210–250 VAC.	Reset building circuit breaker; replace building fuse. Try another outlet.
	Check for motor damage. Remove drive housing assembly. See page 24. Try to rotate fan by hand.	Replace motor (1) if fan won't turn.
	Check for locked motor rotor. Unplug cord and try to turn fan blades with a screwdriver.	Repair gear train or pump, if damaged. Thaw the sprayer, if frozen; See NOTE 1. Replace the pressure control, if damaged.
	Check for shorted motor. Use ohmmeter to check for shorts between motor leads or between motor leads and motor frame.	Inspect for damage to motor brush leads. Replace motor, if necessary.
Defective pressure control transducer.	Replace pressure control transducer. See page 18.	
Poor spray pattern	Check for worn spray tip.	Relieve pressure and then replace the tip. See the separate gun or tip manual.

# Troubleshooting

TYPE OF PROBLEM	WHAT TO CHECK <i>If check is OK, go to next check</i>	WHAT TO DO <i>When check is not OK refer to this column</i>
Motor runs and pump strokes, but output is low or there is no output.	Check extension cord size and length.	Replace cord with a larger size, grounding type extension cord.
	Check paint supply.	Refill and reprime pump.
	Check for clogged intake strainer.	Remove and clean strainer and reinstall.
	Check for loose suction tube or loose fittings.	Tighten; use thread sealant or sealing tape on threads, if necessary.
	Check for worn spray tip.	Follow <b>Pressure Relief Procedure Warning</b> , then replace tip. See your separate gun or tip manual.
	Check motor brushes; check for loose leads and terminals, minimum 13 mm brush length, broken or misaligned springs, or brushes binding in holders. See page 15.	Replace parts as needed. See page 15.
	Check motor armature for shorts by using an armature tester (growler).	Replace motor. See page 21.
	Check to see if pump continues to stroke when gun trigger is released. With pump on and primed, trigger gun momentarily, then release and engage safety latch. Relieve pressure, turn off and unplug sprayer.	Service pump. See manual 308–798.
	Check to see if intake valve ball and piston ball are seating properly.	Remove intake valve and clean. Check balls and seats for nicks; replace if necessary. See manual 308–798. Strain paint before using to remove particles that could clog the pump.
	Check for leaking around throat packing nut which may indicate worn or damaged packings.	Replace packings. See manual 308–798. Also check piston valve seat for hardened paint or nicks and replace if necessary. Tighten the packing nut/wetcup.
Defective pressure control transducer.	Replace pressure control transducer. See page 18.	
Motor runs but pump does not stroke.	Check displacement pump connecting rod pin (20). See page 25.	Replace pin, if missing. Be sure retainer spring (35) is fully in groove all around connecting rod. See page 25.
	Check for frozen or hardened paint in the pump (39).	Thaw. See NOTE 1. Plug in sprayer and turn on. Slowly increase pressure setting to see if motor starts.
	Be sure crank in drive housing rotates; plug in sprayer and turn on briefly to check. Turn off and unplug sprayer.	Check drive housing assembly for damage and replace if necessary. See page 26.
Motor is hot and runs intermittently.	Determine if sprayer was operated at high pressure with small tips, which causes low motor RPM and excessive heat build up.	Decrease pressure setting or increase tip size.
	Be sure ambient temperature where sprayer is located is no more than 90° F and sprayer is not located in direct sun.	Move sprayer to shaded, cooler area, if possible.
	Determine if sprayer was turned on, pressurized, but not operating for long periods of time.	Turn off sprayer whenever you stop spraying for a while and relieve fluid pressure.

**NOTE 1:** Thaw the sprayer if water or water-based paint has frozen in it, by placing it in a warm area. Do not try to start the sprayer until it has thawed completely. If paint hardened (dried) in the sprayer, replace the pump packings. See manual 308–798.

# General Repair Information

## CAUTION

To reduce the risk of a pressure control malfunction:

- Always use needle nose pliers to disconnect a wire. Never pull on the wire, pull on the connector
- Mate wire connectors properly. Be sure flat blade of insulated male connector is centered in wrap-around blade of female connector.
- Route wires carefully to avoid interference with other connections of pressure control. Be sure wires are not pinched between cover and control box.

### Tool List

Phillips screwdriver	1/4 in. hex key wrench
Small flat blade screwdriver	3/16 in. hex key wrench
Needle nose pliers	5/8 in. socket wrench
Plastic mallet or 20 oz (max) hammer	3/8 in. open end wrench
12 in. adjustable wrench	1/2 in. open end wrench
Adjustable, open-end wrench	3/4 in. open end wrench
Torque wrench	7/8 in. open end wrench
	High quality motor oil
	Bearing grease

1. **Keep all screws, nuts, washers, gaskets, and electrical fittings** removed during repair procedures. These parts are not normally provided with replacement assemblies.

## WARNING



### ELECTRIC SHOCK HAZARD

To reduce the risk of serious injury, including electric shock, **DO NOT** touch any moving parts or electrical parts with your fingers or a tool while inspecting the repair. Shut off the sprayer and unplug it as soon as you complete the inspection. Reinstall all covers, gaskets, screws and washers before operating the sprayer.

2. **Test repair** after problem is corrected.
3. **If sprayer does not operate properly**, review repair procedure again to verify that everything was done correctly. If necessary, see Troubleshooting, pages 12 – 13, to help identify other possible problems and solutions.

## WARNING



### EXPLOSION HAZARD

During operation, the motor and drive housing become very hot and could burn your skin if touched. Flammable materials spilled on the hot, bare motor could cause a fire or explosion. Always have the motor shield in place during regular operation to reduce the risk of burns, fire or explosion.

## CAUTION

Do not run the sprayer dry for more than 30 seconds to avoid damaging the pump packings.

4. **Reinstall motor shield before regular operation** of sprayer and replace if damaged. The cover directs cooling air around the motor to help prevent overheating. It can also help reduce the risk of burns, fire or explosion; see preceding **WARNING**.

# Motor Brush Replacement

**NOTE:** Replace brushes worn to less than 13 mm. Note that brushes wear differently on each side of motor, so check both. Brush Repair Kit 220–157 is available. A new spring clip, 110–816, may be purchased separately.

**⚠ WARNING**

**INJECTION HAZARD**  
To reduce the risk of serious injury, whenever you are instructed to relieve pressure, follow the **Pressure Relief Procedure** on page 8.



**NOTE:** Read **General Repair Information** on page 14 before doing this procedure.

1. Relieve pressure.
2. Remove motor shield (54). Remove inspection covers (B) and gaskets on each side of motor. See Fig. 9.

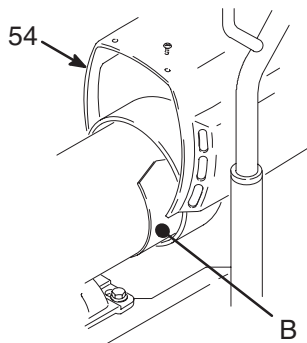

**Fig. 9** 7703B

3. Push in spring clip to release hooks from brush holder. Pull out spring clip. See Fig. 10.

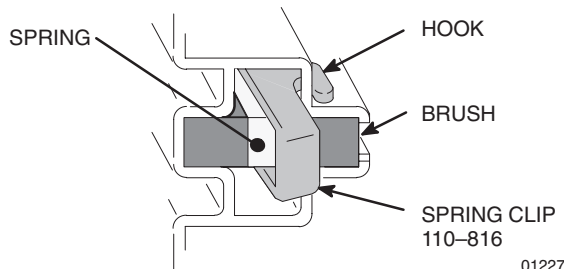

**Fig. 10** 01227

4. Loosen brush lead terminal screw. Pull brush lead away, leaving motor lead terminal in place. Remove brush and spring. See Fig. 12.

5. Inspect commutator for excessive pitting, burning or gouging. A black color on commutator is normal. Have commutator resurfaced by a qualified motor repair shop if brushes seem to wear too fast.

**⚠ CAUTION**

When installing the brushes, follow all steps carefully to avoid damaging the parts.

6. Install new brush so lead is in long slot of holder. See Fig. 11.

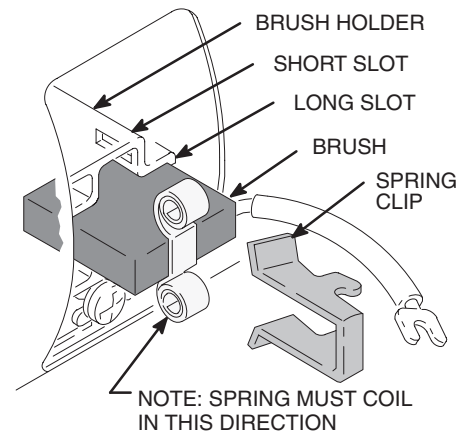

**Fig. 11** 01227

7. Slide terminal under terminal screw washer and tighten screw. Be sure motor lead is still connected at screw. See Fig. 12.

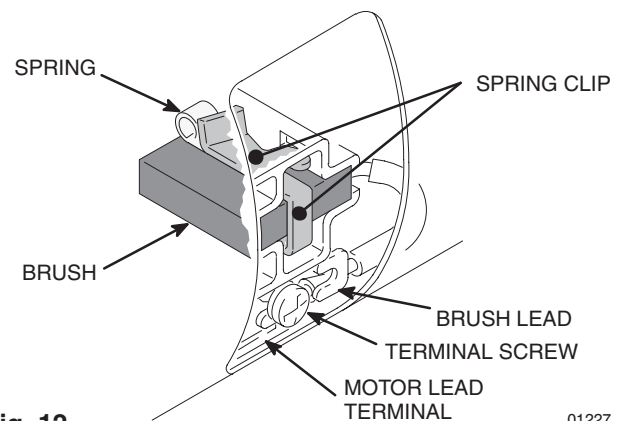

**Fig. 12** 01227

8. Place spring on brush as shown in Fig. 11.
9. Install spring clip and push it down to hook short slots in housing. See Fig. 11.
10. Repeat for other side.



# Motor Brush Replacement

## 11. Test brushes.

- a. Remove pump connecting rod pin.
- b. With sprayer OFF, turn pressure control knob fully counterclockwise to minimum pressure. Plug in sprayer.
- c. Turn sprayer ON. Slowly increase pressure until motor is at full speed.
- d. Inspect brush and commutator contact area for excessive arcing. Arcs must not trail or circle around commutator surface.

## **WARNING**



### **ELECTRIC SHOCK HAZARD**

Do not touch brushes, leads, springs or brush holders when sprayer is plugged in to reduce risk of electric shock and serious bodily injury.

## **CAUTION**

Do not run the sprayer dry for more than 30 seconds while checking the brushes to avoid damaging the displacement pump packings.

## 12. Install brush inspection covers and gaskets.

## 13. Break in brushes.

- a. Operate sprayer for one hour with no load.
- b. Install connecting rod pin.



# Pressure Control

## ⚠ CAUTION

Do not install the pressure control until motor is checked. A defective motor may damage the pressure control. Make sure to test the motor prior to pressure control installation.

## ⚠ WARNING



### ELECTRIC SHOCK HAZARD

To reduce the risk of Electric Shock: wait 5 minutes after turning sprayer off before servicing to allow stored current to discharge.

## Motor Test

With motor shield off and four motor leads disconnected:

1. Check continuity with multimeter from each black motor lead to ground (one at a time). Any reading less than infinite resistance – even very high resistance – means motor is shorted to ground. Replace motor.

## ⚠ CAUTION

A motor that is shorted to ground will damage the pressure control.

2. Remove fan cover from motor.
3. Remove pump pin ( See page 25 for instructions to remove pin).
4. With black motor leads not connected, use motor fan to spin motor quickly. Motor should spin freely in both directions. If not, replace motor.
5. Connect black motor leads together.
6. Use motor fan to turn motor. It should be much harder to turn than in step 4. If there is uneven or no resistance to turning, check brushes and replace if necessary.
7. If there is still uneven or no resistance to turning, replace motor.
8. Install pump pin and fan cover.

## Pressure Control Replacement

## ⚠ WARNING



### INJECTION HAZARD

To reduce the risk of serious injury, whenever you are instructed to relieve pressure, follow the **Pressure Relief Procedure** on page 8.

1. Relieve pressure.
2. Remove two screws (19) holding filter assembly (A). See Fig. 14 and parts list, except as noted.
3. Remove filter assembly by unthreading swivel union (15) from hex nipple (103). Unthread nipple from pressure control (5)
4. Remove 8 screws (64) and motor shield (14).
5. Remove outlet cover (221) on pressure control wiring box. Disconnect motor leads. See Fig 13.
6. Loosen electrical tubing (22) from pressure control fitting and pull out wires
7. Remove hose (28) from rear of pressure control swivel union (15).
8. Support pressure control (5) and carefully remove motor mount screws (37). Remove pressure control.
9. Install new pressure control (5) with screws (37).
10. Continue to assemble sprayer.

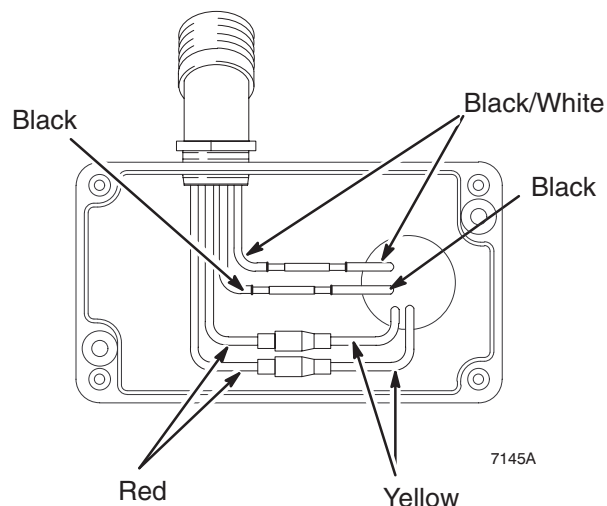

Fig 13

# Pressure Control

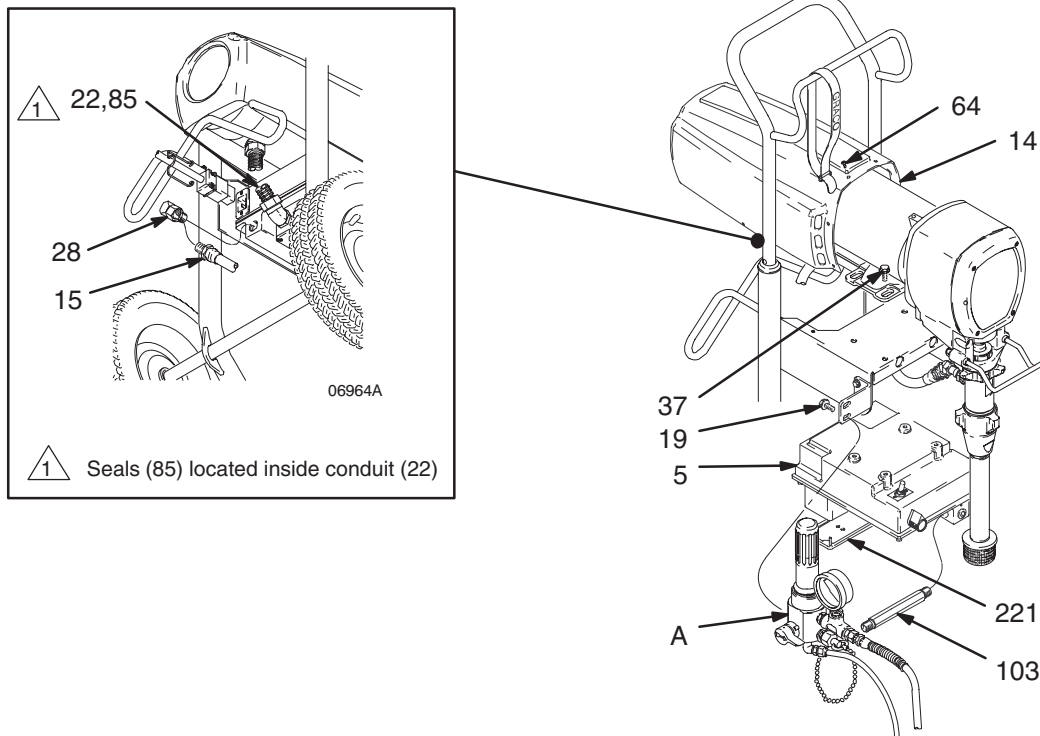

Fig 14

8184A

## Pressure Control Repair

### General Repair and Replacement

#### **⚠ WARNING**



#### **INJECTION HAZARD**

To reduce the risk of serious injury, whenever you are instructed to relieve pressure, follow the **Pressure Relief Procedure** on page 8.

1. Relieve pressure.
2. Remove power cord (90) and plug retainer (89) by removing screws (230) and washers (229).
3. Remove screws (213) and lockwashers (214). Carefully remove control housing (202) from control motor board (201) so internal wiring is not damaged. Lay housing on side next to control motor board. See Fig. 15 and parts list.
4. Remove and replace only those components and wires necessary for repair. Make a diagram showing wire hook-ups for items removed to insure correct wiring when reinstalling. See Fig 16 for wiring information.

5. Install control housing (202) to motor control board (201) using screws (213) and lockwashers (214).

### Pressure Control Transducer and O-Ring Replacement

#### **⚠ WARNING**



#### **FIRE AND EXPLOSION HAZARD**

Proper o-ring replacement is essential to reduce the risk of fire or explosion which can result in serious injury and property damage. Also read **FIRE OR EXPLOSION HAZARD** on page 4.



**NOTE:** Do not replace o-ring unless damaged or if leakage is seen around weep hole, o-ring or transducer.

1. See Fig. 15 and pressure control part list. Disassemble pressure control as in steps 1 through 4 on page 18 and remove old transducer (219) and, if necessary, old o-ring (220).

# Pressure Control Repair

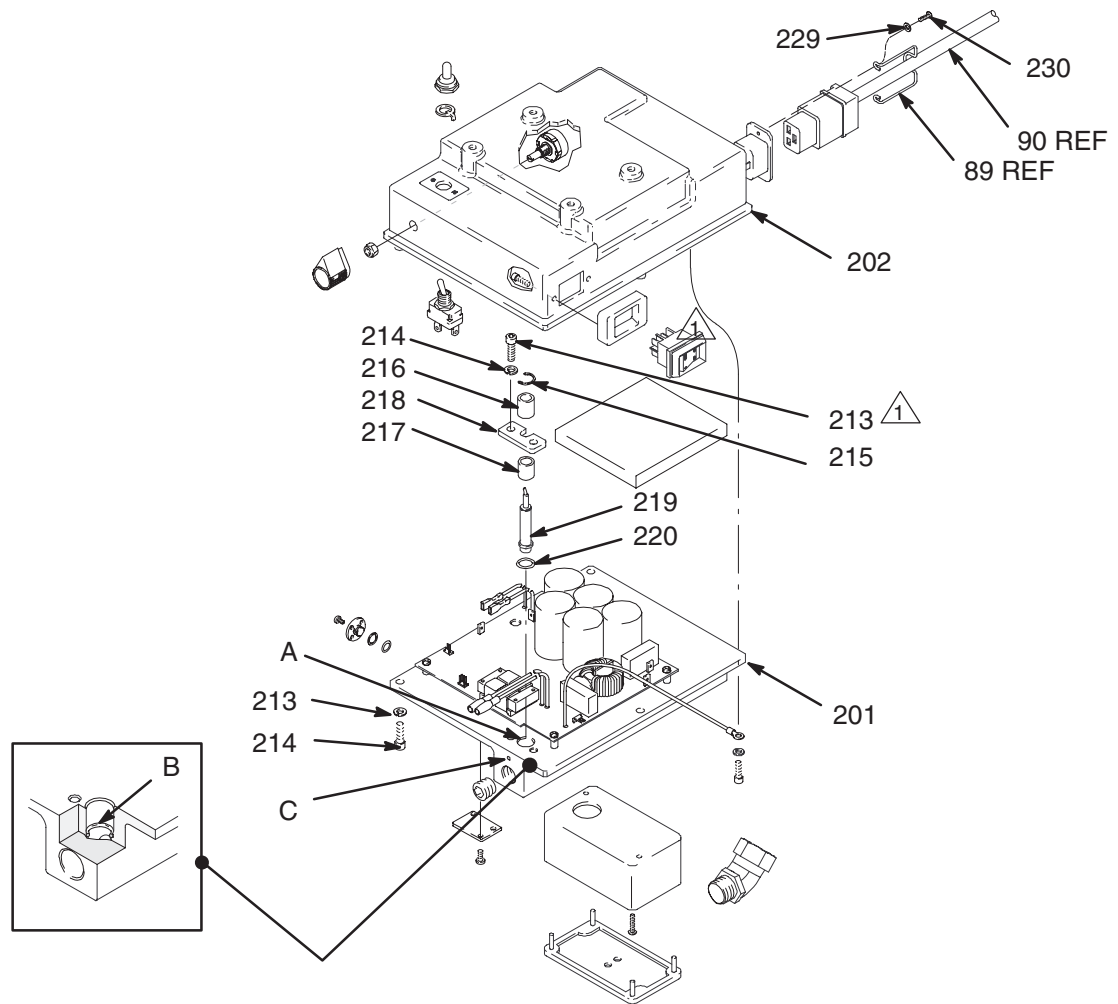

 Torque to 150 in-lb (17 N.m)

8185A

**Fig 15**

2. Carefully slide new o-ring (220) down bore (A) of motor control (201) into o-ring groove (B). Make sure o-ring is in groove around its entire circumference.
3. Carefully slide new transducer and plastic spacer (217) down bore. Loosely attach bracket (218), screws (213), and washers (214).
4. Seat transducer into o-ring by drawing down screws and washers until bracket is flush with motor control surface.
5. Carefully remove transducer and verify that o-ring is seated correctly and not pushed out of groove. If not seated correctly use new o-ring and repeat steps 2 through 5.
6. When o-ring is correctly installed, reinstall transducer and tighten screws to 150 in-lb (17 N.m). Install spacer (216) and C-clip (215). Connect electrical lead and assemble sprayer.
7. Follow Operation Startup procedures for sprayer on page 8 using compatible fluid.
8. Inspect weep hole (C) for any leakage.
9. If any leakage is present, replace o-ring repeating steps 1 through 9.

# Pressure Control Wiring

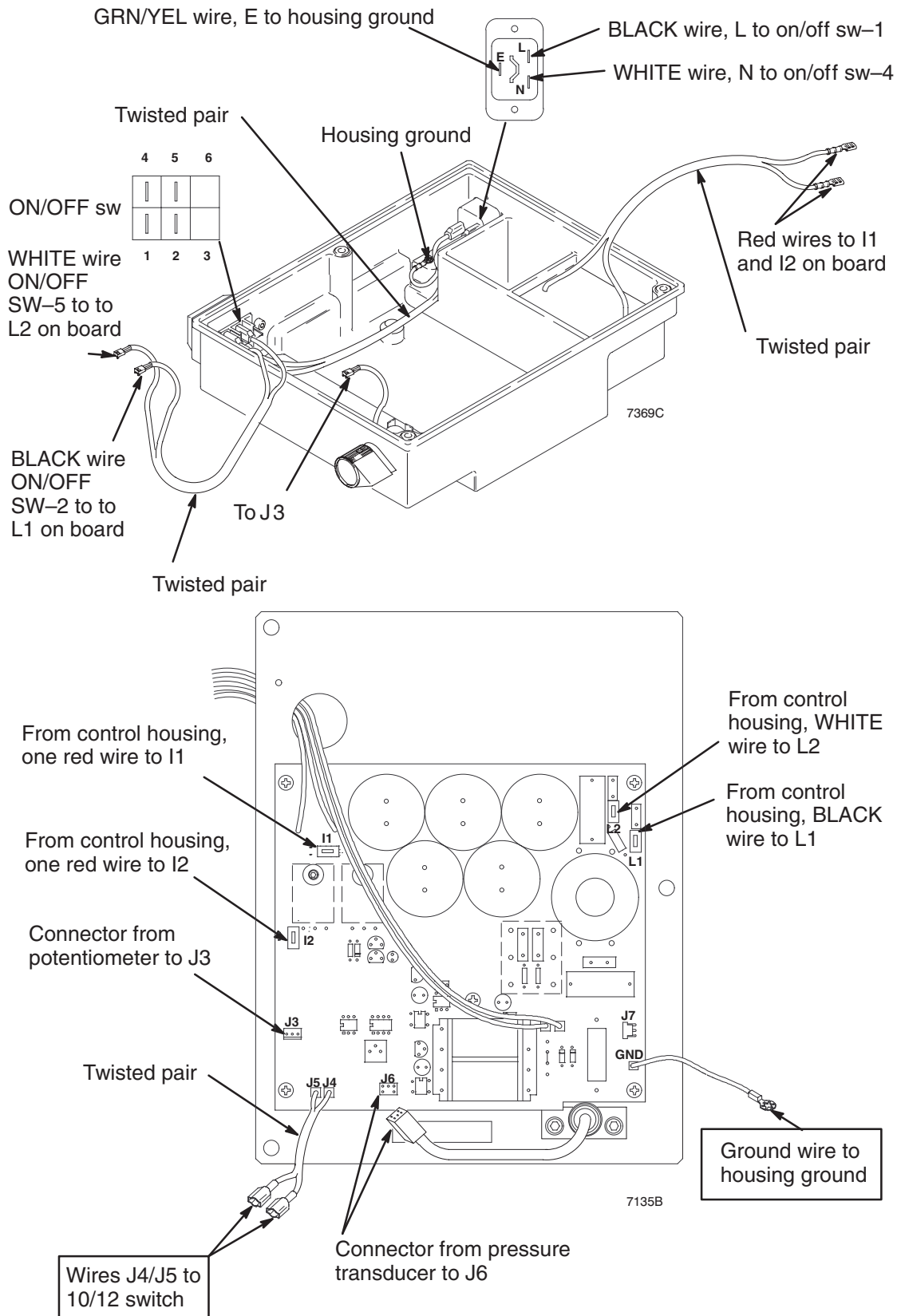

Fig 16

# Motor Replacement

## WARNING



### INJECTION HAZARD

To reduce the risk of serious injury, whenever you are instructed to relieve pressure, follow the **Pressure Relief**

**Procedure** on page 8.

## WARNING



### ELECTRIC SHOCK HAZARD

To reduce the risk of Electric Shock: wait 5 minutes after turning sprayer off before servicing to allow stored current to dis-

charge.

**NOTE:** Refer to Fig. 17 and parts list, except as noted.

1. Relieve pressure.
2. Remove motor shield (14). Remove front cover (31). Disconnect hose (28) at pump. Disconnect drain hose (79) from pump (39).
3. Remove outlet cover on pressure control wiring box. Disconnect four motor leads. See Fig 13.
4. Unscrew conduit connector (16) from motor and pull motor leads from tubing (22).
5. Remove screws (33) from recess of drive housing.
6. Remove screws (21 and 30) from motor bell (F).
7. Use a plastic mallet to tap displacement pump (39) from rear to loosen drive housing (18) from motor bell (F). Pull off drive housing.

## CAUTION

DO NOT drop gear cluster (9) when removing drive housing (18). The gear cluster may stay engaged in the motor front end bell or the drive housing.

DO NOT lose thrust balls (10) located at each end of gear cluster (9) or drop them between gears. The balls, which are heavily covered with grease, usually stay in the shaft recesses, but could be dislodged. If caught between gears and not removed, the balls will seriously damage the drive housing. If the balls are not in place, the bearings will wear prematurely.

8. Lower pressure control (5) by unscrewing motor mounting screws (37).
9. Lift off motor (1).
10. Mount and center new motor on frame and attach pressure control (5) with motor mounting screws (37).
11. Insert motor leads through connector (16) and tubing (22) to pressure control. Screw connector (125) two or three threads into motor. Tighten locknut up to motor. Connect four motor leads. See Fig. 13.
12. Liberally grease gear cluster (9) and pinion gear (G) and pack all bearings in motor bell. Be sure thrust balls (10) are in place. (One ball is included with a replacement drive housing.)
13. Align gears and push drive housing (18) straight onto motor bell (F) and locating pins.
14. Continue to reassemble sprayer.

# Motor Replacement

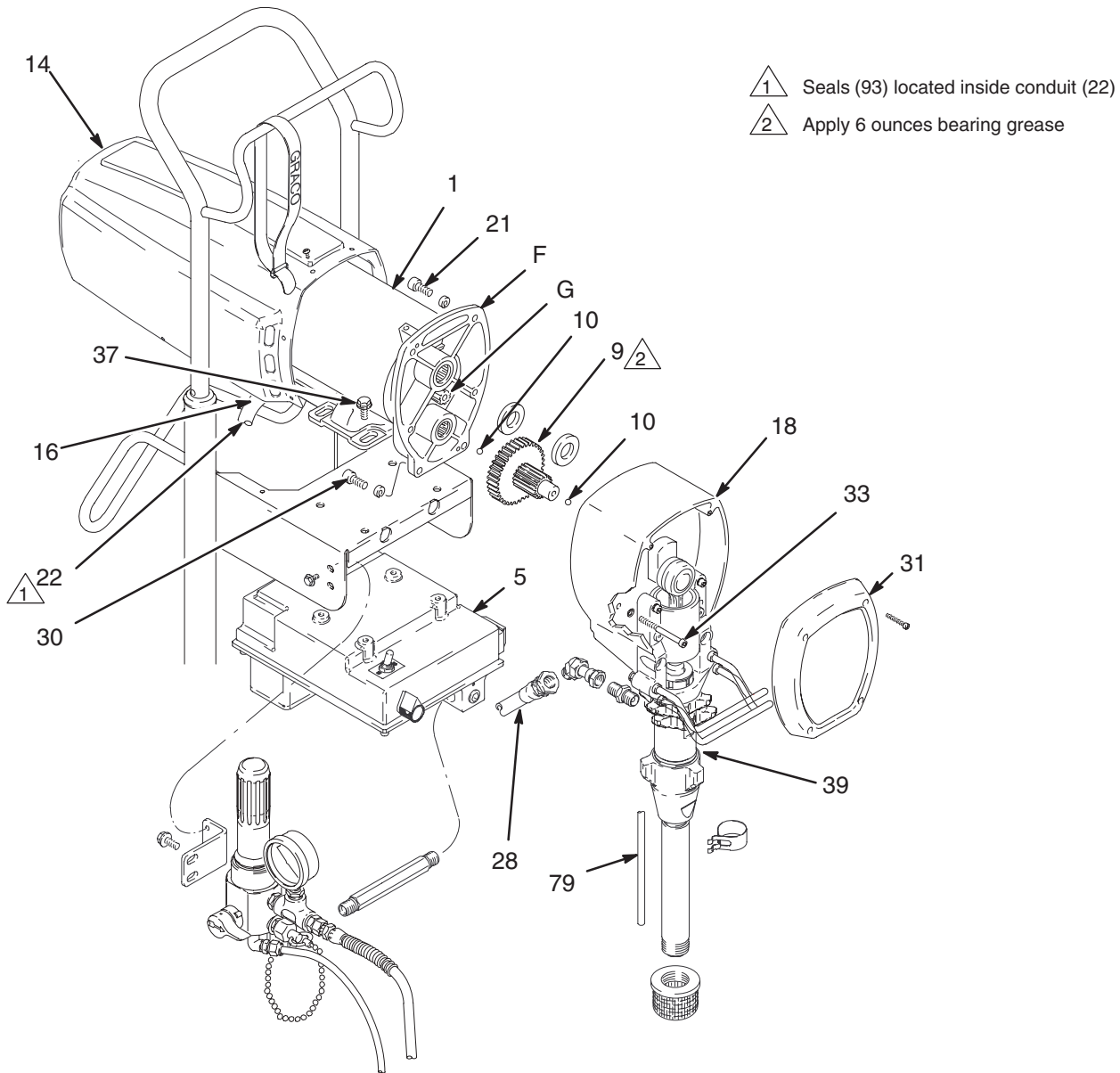

Fig. 17

# Bearing Housing and Connecting Rod Replacement

## ⚠ WARNING



### INJECTION HAZARD

To reduce the risk of serious injury, whenever you are instructed to relieve pressure, follow the **Pressure Relief Procedure** on page 8.

**NOTE:** Read **General Repair Information** on page 14 before doing this procedure. See Fig. 18.

**NOTE:** Stop sprayer at bottom of its stroke to get crank (E) in its lowest position. To lower crank manually, carefully rotate blades of fan with a screwdriver.

1. Relieve pressure.
2. Remove front cover (31). Unclip drain hose (79) from pump. Hold a wrench on pump intake valve (H) and unscrew pump suction tube (42). Disconnect pump hose (28).
3. Push up retaining spring (35). Push pin (20) out rear.
4. Loosen locknut (38). Unscrew displacement pump (39).
5. Remove four screws (33) and lockwashers (49).
6. Lightly tap lower rear of bearing housing (27) with a plastic mallet to loosen it from drive housing (14). Pull bearing housing and connecting rod assembly (29) straight off drive housing.
7. Remove pail bracket assembly (F) and install with locknuts (13) on new bearing housing.
8. Inspect crank (E) for excessive wear and replace parts as needed. Evenly lubricate inside of bronze bearing (B) with high quality motor oil. Liberally pack roller bearing (C) with bearing grease.
9. Assemble connecting rod (29) and bearing housing (27).
10. Clean mating surfaces of bearing (27) and drive (14) housings.

11. Align connecting rod (29) with crank (E) and drive housing locating pins (G) with bearing housing (27) holes. Push bearing housing onto drive housing or tap it into place with a plastic mallet.

## ⚠ CAUTION

DO NOT use the bearing housing screws (33) to try to align or seat the bearing housing; the bearing and drive housing will not align properly and will result in premature bearing wear.

12. Install screws (33) and lockwashers (49). Tighten screws evenly to 300 in-lb (34 N.m).
13. Install pump. See page 26.
14. Install remaining parts. See Fig. 18.

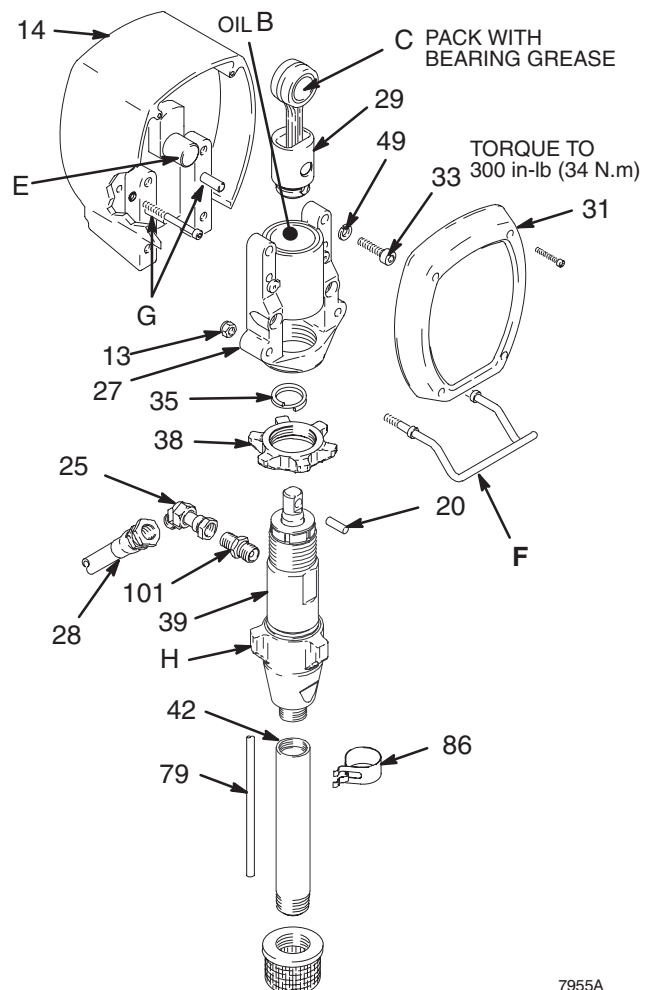

Fig. 18

7955A



# Drive Housing Replacement

## ⚠ WARNING



### INJECTION HAZARD

To reduce the risk of serious injury, whenever you are instructed to relieve pressure, follow the **Pressure Relief Procedure** on page 8.

**Procedure** on page 8.

## ⚠ CAUTION

DO NOT drop gear cluster (9) when removing drive housing (18). Gear cluster may stay engaged in the motor front end bell or the drive housing.

DO NOT lose thrust balls (10) located at each end of gear cluster (9) or drop them between gears. The balls, which are heavily covered with grease, usually stay in the shaft recesses, but could be dislodged. If caught between gears and not removed, the balls will seriously damage drive housing. If the balls are not in place, the bearings will wear prematurely.

**NOTE:** Read **General Repair Information** on page 14 before doing this procedure. See Fig. 19.

1. Relieve pressure.

2. Remove front cover (31) and motor shield (14).  
Unclip drain hose (79) from pump.

3. Remove four bearing housing screws (33) and lockwashers (49).
4. Lightly tap lower rear of bearing housing (27) with a plastic mallet to loosen it from drive housing (18). Pull assembled bearing housing and connecting rod straight off drive housing.
5. Remove two drive housing screws (51) and lockwashers (63).
6. Remove two lower screws (30) and lockwashers (63) and then two upper screws (30) and lockwashers (63) from front of motor (1).
7. Tap drive housing (18) with a plastic mallet to loosen it from front of motor (1), and then pull drive housing straight off.
8. Liberally apply approximately 4 ounces of bearing grease to gear cluster (9). Grease is supplied with drive housing replacement kit. Be sure thrust balls (10) are in place.
9. Align gears and push new drive housing straight onto front of motor and locating pins.
10. Continue reassembling sprayer.

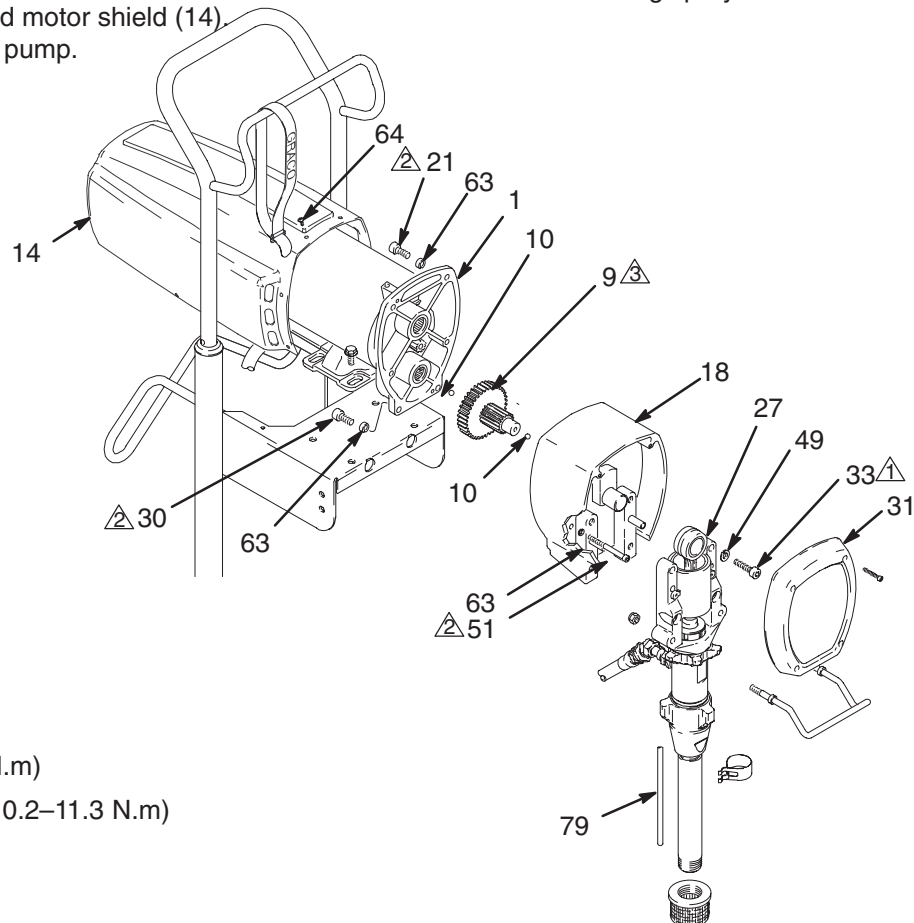

- 1 ⚠ Torque to 300 in-lb (34 N.m)
- 2 ⚠ Torque to 90–100 in-lb (10.2–11.3 N.m)
- 3 ⚠ Liberally apply grease

Fig. 19

7956A



# Displacement Pump Repair

## Removing pump

1. Flush pump. Relieve pressure. Fig. 20. Cycle pump with piston rod (222) in its lowest position.
2. Fig. 20. Unscrew suction tube and hose from pump.

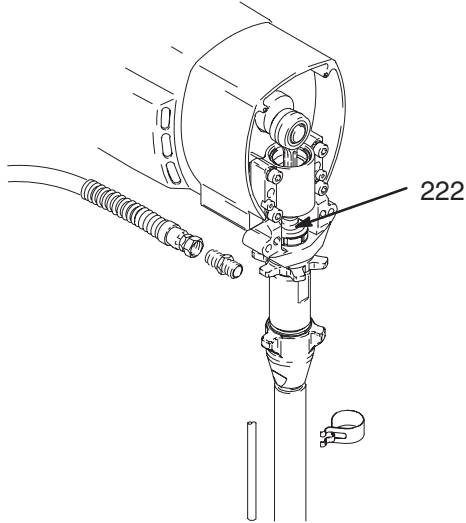

**Fig. 20** 7672A

3. Fig. 21. Use screwdriver to push retaining spring (35) up and pin (20) out.

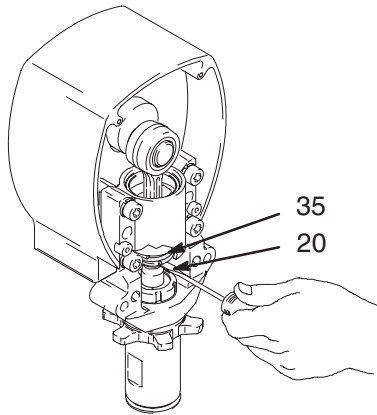

**Fig. 21** 7674A

4. Fig. 22. Loosen locknut by hitting firmly with a 20 oz (maximum) hammer. Unscrew pump.

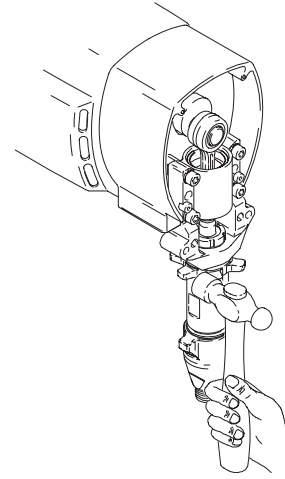

**Fig. 22** 7673A

## Repairing Pump

See manual 308–798 for pump repair instructions.

# Displacement Pump Repair

## Installing pump

### **⚠ WARNING**

If the pin works loose, it or other parts could break off due to the force of the pumping action. These parts could be projected through the air and result in serious bodily injury or property damage, including damage to the pump, connecting rod or bearing housing.

### **⚠ CAUTION**

If the pump locknut loosens during operation, the threads of the bearing housing will be damaged.

1. Fig. 23. Pull piston rod out 1.5 in. Screw in pump until holes in bearing cross link and piston rod align.

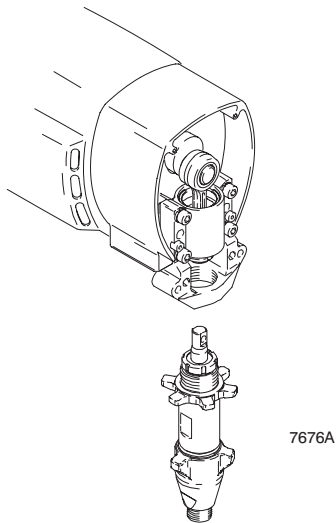

**Fig. 23**

2. Fig. 24. Push pin (21) into holes.

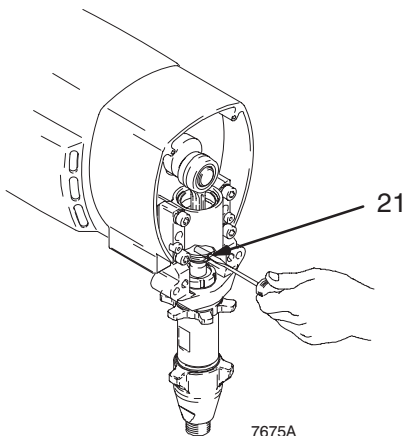

**Fig. 24**

3. Fig. 25. Push retaining spring into groove all the way around connecting rod.

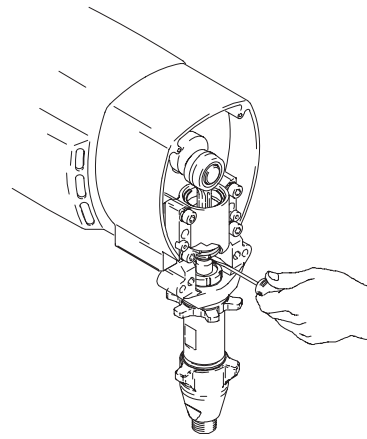

**Fig. 25**

Fig. 26. Screw jam nut down onto pump until stops. Screw pump up into bearing housing until it is stopped by jam nut. Back off pump and jam nut to align pump outlet to back. Tighten jam nut by hand, then tap 1/8 to 1/4 turn with a 20 oz (maximum) hammer to approximately  $75 \pm 5$  ft-lb (102 N·m).

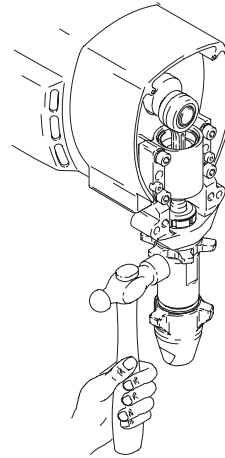

**Fig. 26**

Fig. 27. Fill packing nut with Graco TSL, through one of the slits, until fluid flows onto the top of seal.

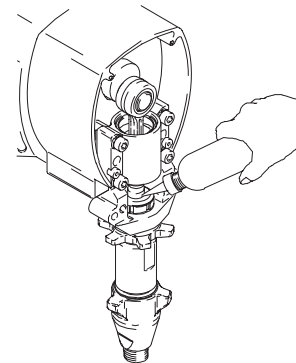

**Fig. 27**

# Accessories

## DANGER LABELS

The English language DANGER label shown on page 4 is also on your sprayer. If you have painters who do not read English, order one of the following labels to apply to your sprayer. The drawing shows the best placement of these labels for good visibility.

Order the labels directly from Graco, free of charge. Toll Free: 1-800-328-0211

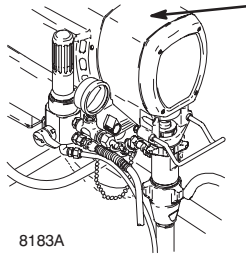

Apply other language here

French	187-784
Spanish	185-962
German	186-042
Greek	186-046
Korean	186-050

# Technical Data

Power Requirements . . . . . 230 VAC, 50 Hz,  
1 phase, 12A minimum or 5000W generator

Motor 1.6. . . . . HP  
with latex at 138 bar (13.8 MPa, 2000 psi)

Working Pressure Range 0-210 bar (0-21 MPa, 0-3000 psi)

Cycles/Gallon (liter) . . . . . 118 (31)

Maximum Delivery Rating . . . . . 1.25 gpm (4.75 lpm)

Tip Size: one gun - 0.035; two guns - 0.023; three guns - 0.018  
with latex at 138 bar (13.8 MPa, 2000 psi)

Power Cord . . . . . 1.5 mm<sup>2</sup> by 4.5 m, 3 wire

Inlet Paint Strainer . . . . . 16 mesh (975 micron)  
stainless steel screen, reusable

Outlet Paint Filter . . . . . 60 mesh (238 micron)  
stainless steel screen, reusable

Pump Inlet Size . . . . . 3/4 npt(m)

Fluid Outlet Size  
Filter . . . . . 3/8 npt(f)  
Filter with standard 3/8 npt(f) to 1/4 npsm adapter 1/4 npsm

Sound Data  
Sound pressure level at one meter . . . . . 85.3 db(A)  
Sound power level . . . . . 95.2 db(A)  
Measured under maximum operating conditions per  
ISO-3744

Basic Sprayer Wetted Parts: . . . . . zinc-plated carbon steel,  
polyurethane, polyethylene, stainless steel,  
PTFE®, Delrin®, chrome plating, leather,  
V-Max™ UHMWPE, aluminum,  
stainless steel, tungsten carbide

**NOTE:** Delrin® and PTFE®

# Dimensions

Weight (dry w/o packaging) . . . . . 140 lb (63.5 kg)

Height . . . . . 30.5 in. (775 mm)

Length . . . . . 25.5 in. (648 mm)

Width . . . . . 22.5 in. (572 mm)

# Parts Drawing – Sprayer

**Ultra MAX 1595 Sprayer**  
**Model 232-164, Series A**  
 Includes items 1 – 108  
 Basic Sprayer

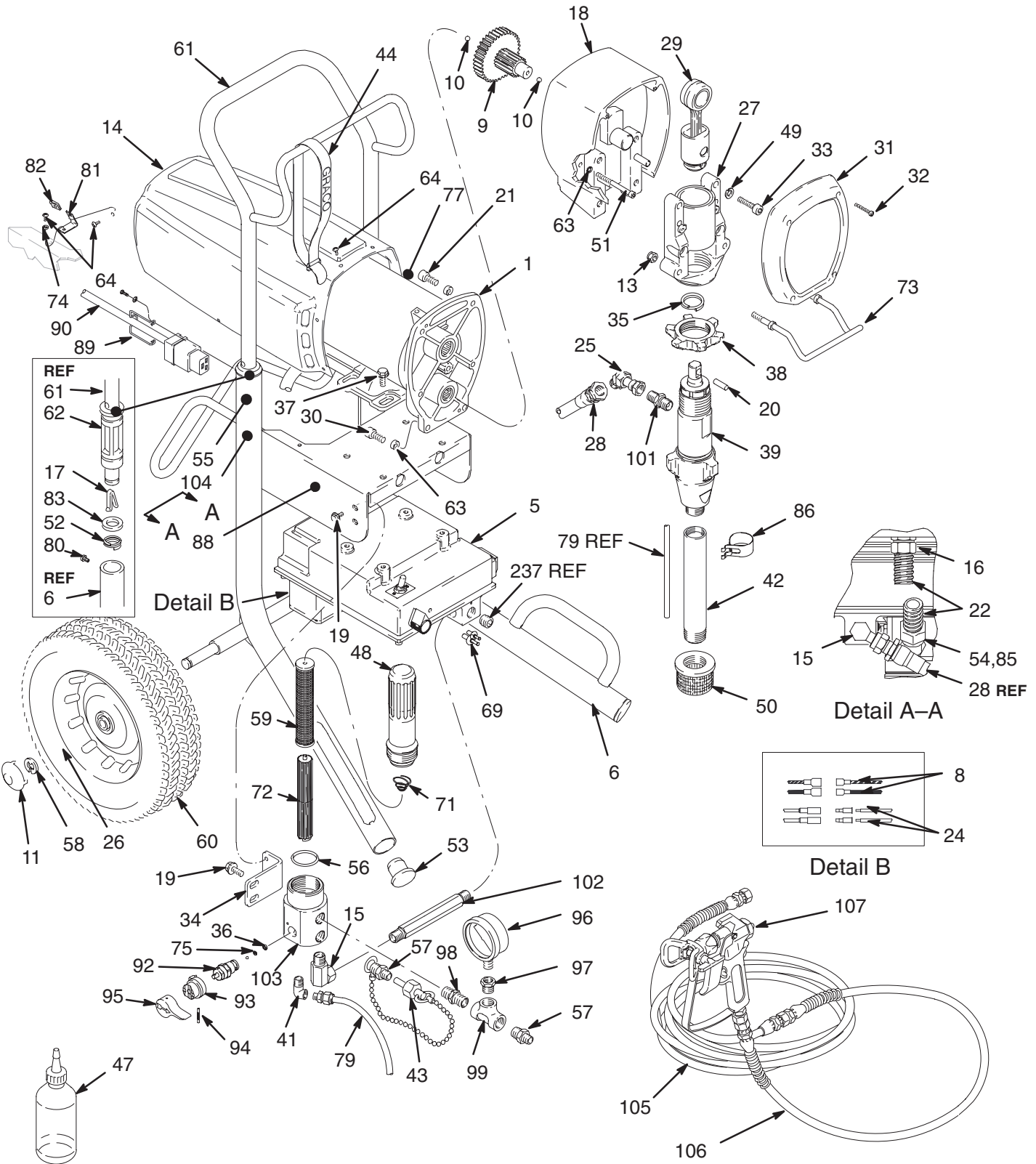

7951A

# Parts List – Sprayer

## Ultra MAX 1595 Sprayers

### Model 232–164 Series A

Includes items 1 – 108

Complete Sprayer

REF NO.	PART NO.	DESCRIPTION	QTY	REF NO.	PART NO.	DESCRIPTION	QTY
1	235–726*	<b>MOTOR, ELECTRIC</b> <i>includes 41 and 73a</i>	1	60	179–811	WHEEL, semi–pneumatic	2
5	239–429	<b>PRESSURE CONTROL</b> <i>see parts list on page 31</i>	1	61	240–136	HANDLE, cart	1
6	240–143	FRAME, cart	1	62	192–027	SLEEVE, cart	2
8	107–266	TERMINAL	2	63	105–510	WASHER, lock, spring	6
9	220–637	<b>GEAR REDUCER</b>	1	64	108–865	SCREW, machine, pan hd	10
10	100–069	BALL	2	69	111–482	RIVET, snap	1
11	104–811	CAP, hub	2	71	171–941	SPRING, compression	1
13	112–746	LOCKNUT, 5/16 –18	2	72	186–075	SUPPORT, filter	1
14	240–483	<b>SHIELD, motor</b> (includes label 77)	1	73	192–719	HANGER, pail	1
15	155–494	UNION, swivel, 90°	2	74	100–020	CONNECTOR, tube, female	2
16	10–138	CONNECTOR, conduct	1	75	187–615	VALVE, seat	1
17	112–827	BUTTON, snap	2	77▲	187–791	LABEL, danger, English	1
18	220–879	<b>DRIVE HOUSING</b> <i>includes 67a and 67b</i>	1	79	240–144	HOSE, drain	1
19	114–402	SCREW, hex hd, flanged	4	80	109–032	SCREW, machine, pan hd	4
20	183–210	PIN, straight, hdls	1	81	185–384	BRACKET	2
21	100–644	SCREW, cap	2	82	110–240	NUT, self–retaining	2
22	065–312	TUBING, electrical, flexible, 5.5 in.	1	83	183–350	WASHER	2
24	107–264	TERMINAL	2	85	107–447	SEAL, conduit	2
25	161–889	UNION, swivel	1	86	192–691	CLIP, spring	1
26	154–636	WASHER	2	87▲	290–447	LABEL, warning (on brush covers–not shown)	3
27	240–701	<b>BEARING HOUSING</b>	1	88▲	187–784	LABEL, danger, French	1
28	240–246	HOSE, coupled, 1/4in. by 20 in.	1	89	114–426	RETAINER, plug	1
29	220–640	<b>ROD CONNECTING KIT</b>	1	90	240–539	CORD SET, European	1
30	100–643	SCREW, cap	2		240–540	CORD SET, Italy	1
31	188–423	COVER, housing	1		240–541	CORD SET, Denmark	1
32	108–850	SCREW, mach, filh	4		240–542	CORD SET, Switzerland	1
33	110–141	SCREW, cap, sch	4		240–543	CORD SET, Bare end, European	1
34	193–081	BRACKET, manifold, filter	1		241–852	CORD SET, Australia	1
35	183–169	SPRING, retaining	1	92	235–014	DRAIN VALVE ASSEMBLY	1
36	111–699	GASKET, seat, valve	1	93	224–807	CAM, drain valve	1
37	110–963	SCREW, flange, hex hd	4	94	111–600	PIN, grooved	1
38	193–031	NUT, retaining	1	95	187–625	HANDLE, valve, drain	1
39	240–291	<b>KIT, pump, displacement</b> <i>see manual 308–798 for parts</i>	1	96	102–814	GUAGE, pressure, fluid	1
41	112–538	ELBOW, 90°, street, reducing	1	97	100–176	BUSHING, hex	1
42	193–097	TUBE, suction	1	98	156–849	NIPPLE, pipe	1
43	240–131	PLUG, packless	1	99	100–483	TEE, pipe	1
44	114–271	STRAP, retaining	1	101	162–485	NIPPLE, adapter	1
47	206–994	THROAT SEAL LIQUID, 8 OZ	1	102	193–024	NIPPLE, hex	1
48	240–315	BOWL, filter	1	103	240–700	HOUSING KIT, filter (includes item 56)	1
49	106–115	WASHER, lock, spring	4	104▲	187–975	LABEL, warning, English	1
50	181–072	<b>STRAINER, inlet</b>	1	105	238–361	HOSE, grounded, nylon, 1/4" ID, cpld 1/4 npsm(f), 50 ft (15m) spring guards both ends	1
51	108–849	SCREW, cap, sch	2	106	238–358	HOSE, grounded, nylon, 3/16" ID, cpld 1/4 npsm(f), 3 ft (.9 m) spring guards both ends	1
52	110–243	RING, retaining	2	107	222–667	GUN, contractor, basic	1
53	108–691	PLUG, tubing	2	108	221–621	TIP, spray, cylinder (not shown)	1
54	108–460	CONNECTOR, conduit, 45°	1	109	237–859	GUARD, rac (not shown)	1
55▲	192–839	LABEL, caution	1				
56	104–361	PACKING, o–ring	1				
57	164–672	ADAPTER	2				
58	101–242	RING, retaining, ext.	2				
59	167–025	STRAINER, 60 mesh	1				

▲ Extra Danger and Warning tags and labels available free.

\*Motor Brush Repair Kit 220–157 is available.

Order separately.

# Pressure Control Drawing

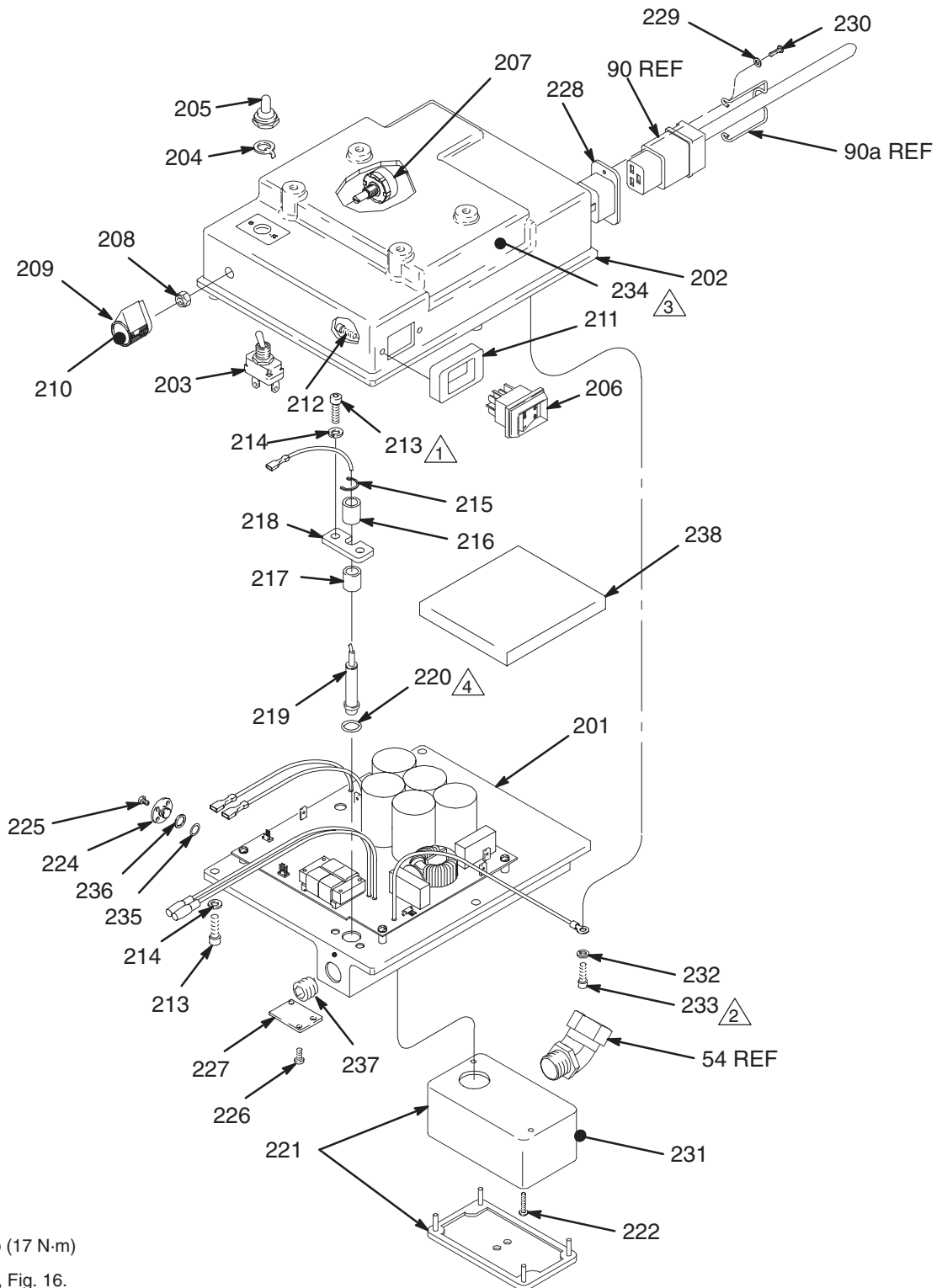

- 1 Torque to 150 in-lb (17 N·m)
- 2 To housing ground, Fig. 16.
- 3 Located this point, inside housing
- 4 WARNING! See Pressure Control Transducer and O-Ring Replacement on page 18 for correct replacement procedure.

Fig 28

7202D

# Pressure Control Parts List

## Part Number 239-429

Pressure Control

Includes items 201 – 327

Ref No.	Part No.	Description	Qty	Ref No.	Part No.	Description	Qty
	239-429	PRESSURE CONTROL <i>See Ref. No. 5 on page 29 for location on Sprayer</i>	1	221	192-050	ELECTRICAL ENCLOSURE KIT	1
				222	M71-503	SCREW	2
				224†	192-142	PLUG	1
201	240-502	MOTOR CONTROL BOARD	1	225†	104-836	SCREW	4
202	239-427	CONTROL HOUSING <i>For complete assembly, order part number 238-976.</i>	1	226†	110-637	SCREW	2
				227†	192-155	COVER	1
				228	113-799	INLET, ac power	1
203	111-930	. SWITCH, toggle (10/12)	1	229	114-027	WASHER, flat	2
204	105-658	. RING, locking	1	230	111-714	SCREW, machine, phillips, pan hd	2
205	105-659	. BOOT, toggle	1	231▲	189-930	LABEL, caution	1
206	111-961	. SWITCH, rocker (on/off)	1	232	157-021	WASHER, lock, internal	1
207	236-352	. POTENTIOMETER (pressure adjust)	1	233	111-593	SCREW, grounding	1
208	112-382	. NUT, shaft sealing	1	234	186-620	LABEL, ground	1
209	114-273	. KNOB, control	1	235†	111-710	O-RING	1
210	193-072	. LABEL, control knob	1	236†	111-711	RING, backup	1
211	192-226	. SPACER, switch	1	237	101-754	PLUG, pipe	1
212	112-788	. SCREW, cap hd	2	238	192-212	PAD, foam	1
213	100-644	SCREW, cap	5	323*	235-009	SWITCH TRANSDUCER (not shown)	1
214	100-016	WASHER, lock	5	324*	192-150	BLOCK, transducer (not shown)	1
215	114-031	CLIP, cee	1	325*	108-850	SCREW, machine, fil hd (not shown)	4
216	192-223	SPACER, transducer	1	326*	111-704	SCREW, machine, fil hd (not shown)	2
217	192-144	SPACER, transducer	1	327*	239-530	SWITCH (not shown)	1
218	192-145	BRACKET, transducer	1				
219	236-353	TRANSDUCER, pressure control	1				
220	104-319	PACKING, o-ring <i>WARNING! See Pressure Control Transducer and O-Ring Replacement on page 18 for correct replacement procedure.</i>	1				

▲ Replacement Danger and Warning labels, tags and cards are available at no cost.

† These parts are included on all sprayers as shipped, but not on replacement pressure control 239-429.

\* These parts are included with replacement pressure control 239-429, but are not on all sprayers as shipped.



# Graco Standard Warranty

Graco warrants all equipment referenced in this document which is manufactured by Graco and bearing its name to be free from defects in material and workmanship on the date of sale by an authorized Graco distributor to the original purchaser for use with the exception of any special, extended, or limited warranty published by Graco. Graco will, for a period of twelve months from the date of sale, repair or replace any part of the equipment determined by Graco to be defective. This warranty applies only when the equipment is installed, operated and maintained in accordance with Graco's written recommendations.

This warranty does not cover, and Graco shall not be liable for general wear and tear or any malfunction, damage or wear caused by faulty installation, misapplication, abrasion, corrosion, inadequate or improper maintenance, negligence, accident, tampering, substitution of non-Graco component parts. Nor shall Graco be liable for malfunction, damage or wear caused by the incompatibility of Graco equipment with structures, accessories, equipment or materials not supplied by Graco, or the improper design, manufacture installation, operation or maintenance of structures, accessories, equipment or materials not supplied by Graco.

This warranty is conditioned upon the prepaid return of the equipment claimed to be defective to an authorized Graco distributor for verification of the claimed defect. If the claimed defect is verified, Graco will repair or replace free of charge any defective parts. The equipment will be returned to the original purchaser transportation prepaid. If inspection of the equipment does not disclose a defect in material or workmanship, repairs will be made at a reasonable charge, which charges may include the costs of parts, labor and transportation.

**THIS WARRANTY IS EXCLUSIVE, AND IS IN LIEU OF ANY OTHER WARRANTIES, EXPRESS OR IMPLIED, INCLUDING BUT NOT LIMITED TO WARRANTY OF MERCHANTABILITY OR WARRANTY OF FITNESS FOR A PARTICULAR PURPOSE.**

Graco's sole obligation and buyer's sole remedy for any breach of warranty shall be as set forth above. The buyer agrees that other remedy (including, but not limited to, incidental or consequential damages for lost profits, lost sales, injury to person or property, or any other incidental or consequential loss) shall be available. Any action for breach of warranty must be brought within two (2) years of the date of sale.

**GRACO MAKES NO WARRANTY, AND DISCLAIMS ALL IMPLIED WARRANTIES OF MERCHANTABILITY AND FITNESS FOR A PARTICULAR PURPOSE, IN CONNECTION WITH ACCESSORIES, EQUIPMENT, MATERIALS OR COMPONENTS SOLD BUT NOT MANUFACTURED BY GRACO.** These items sold, but not manufactured by Graco (such as electric motors, switches, hose, etc.), are subject to the warranty, if any, of their manufacturer. Graco will provide purchaser with reasonable assistance in making any claim for breach of these warranties.

In no event will Graco be liable for indirect, incidental, special or consequential damages resulting from Graco supplying equipment hereunder, or the furnishing, performance, or use of any products or other goods sold hereto, whether due to a breach of contract, breach of warranty, the negligence of Graco, or otherwise.

## **FOR GRACO CANADA CUSTOMERS**

The parties acknowledge that they have required that the present document, as well as all documents, notices and legal proceedings entered into, given or instituted pursuant hereto or relating directly or indirectly hereto, be drawn up in English. Les parties reconnaissent avoir convenu que la rédaction du présente document sera en Anglais, ainsi que tous documents, avis et procédures judiciaires exécutés, donnés ou intentés à la suite de ou en rapport, directement ou indirectement, avec les procédures concernées.

## **ADDITIONAL WARRANTY COVERAGE**

Graco does provide extended warranty and wear warranty for products described in the "Graco Contractor Equipment Warranty Program".

# Graco Phone Number

**TO PLACE AN ORDER**, contact your Graco distributor, or call this number to identify the distributor closest to you: **1-800-690-2894 Toll Free.**

*All written and visual data contained in this document reflects the latest product information available at the time of publication. Graco reserves the right to make changes at any time without notice.*

**Sales Offices:** Minneapolis, Detroit

**Foreign Offices:** Belgium, Korea, Hong Kong, Japan

**GRACO INC. P.O. BOX 1441 MINNEAPOLIS, MN 55440-1441**

**www.graco.com**

PRINTED IN USA 308-844 March 1998, Revised May 1999