

INSTRUCTIONS-REPAIR



308870

Rev. B



KEEP FOR REFERENCE.
Read this and all related manuals for important warnings and instructions.

INSTRUCTIONS

First choice when quality counts.™

GMax® 7900 CE

Airless Paint Sprayer

3300 psi (227 bar, 22.7 MPa) Maximum Working Pressure

GMax 7900

Model	Series	Description
232630	A	Hi-Boy
232631	A	Hi-Boy with RAC IV tip, gun and hose
232632	A	Lo-Boy
232633	A	Lo-Boy with RAC IV tip, gun and hose

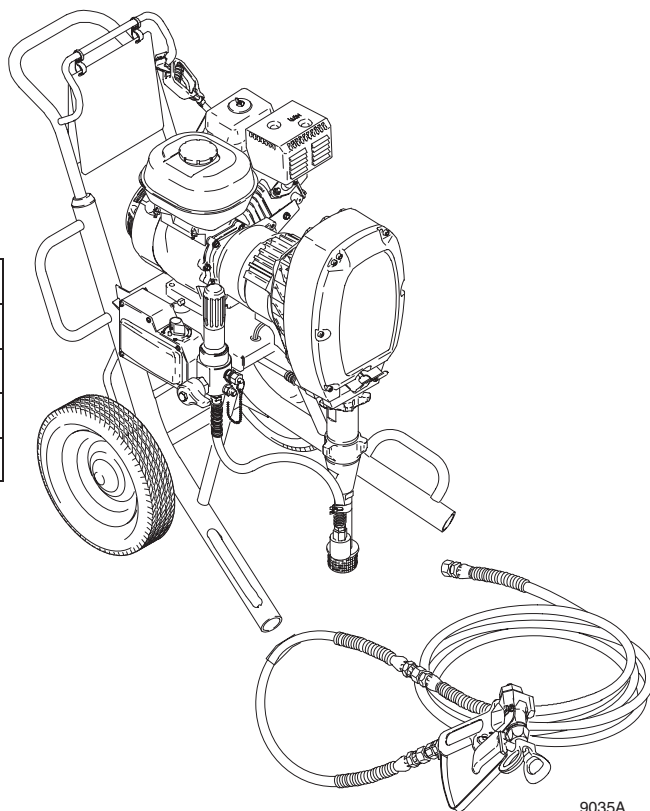

9035A

All models are not available in all countries
PATENTS PENDING

Related Manuals

Operation	308867
Displacement Pump	308798
Spray Gun	307614
Spray Tip	308644
PC Board	308919
Drain Valve Kit	308961

Table of Contents

Warnings and Cautions	2.	Pressure Control	13
Component Identification and Function	3	Displacement Pump	15
Maintenance	4.	Parts	
Troubleshooting	5.	Pinion Assembly	17
Repair		Hi-Boy Sprayers	18
Rollers	7.	Lo-Boy Sprayers	20
Drive Housing	7.	Pressure Control	22
Cam Follower Bearings	8.	Complete Sprayers	24
Pinion Assembly/Rotor/Field/Shaft/Clutch	9	Dimensions	25.
Clamp	10.	Technical Data	25
Clutch Housing	11	Graco Phone Number	25
Engine	11.	Graco Warranty	26

GRACO INC. P.O. BOX 1441 MINNEAPOLIS, MN 55440-1441

©COPYRIGHT 1999, GRACO INC.

Graco Inc. is registered to I.S. EN ISO 9001

Warnings and Cautions

Warning Symbol











This symbol alerts you to the possibility of serious injury or death if you do not follow the instructions.

Caution Symbol

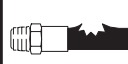

This symbol alerts you to the possibility of damage to or destruction of equipment if you do not follow the instructions.

 WARNING	
<p>Fire and explosion can occur when spraying or flushing flammable fluid in an area where air circulation is poor and flammable vapors can be ignited by an open flame or sparks.</p> <p>To help prevent a fire and explosion:</p> <ul style="list-style-type: none">● Use outdoors or in an extremely well ventilated area.● Do not use 1,1,1-trichloroethane, methylene chloride, other halogenated hydrocarbon solvents or fluids containing such solvents in pressurized aluminum equipment. Such use could result in a chemical reaction, with the possibility of explosion.● Remove, extinguish or unplug all ignition sources; tape wall switch. Do not smoke in spray area.● Never fill fuel tank while the engine is running or hot.● Ground Sprayer, object being sprayed, paint and solvent pails.● Hold gun firmly to side of a grounded pail when triggering into pail.● Use only conductive airless paint hose.● Never run engine in inclosed area.	
<p>Fluid injection is a serious injury! If high pressure fluid pierces your skin, the injury might look like "just a cut". But it is a serious wound! Get immediate medical attention.</p> <p>To help prevent injection, always:</p> <ul style="list-style-type: none">● Engage trigger safety latch when not spraying.● Point gun away from yourself or anyone else.● Relieve pressure before checking or repairing any leak.● Relieve pressure when you turn off the sprayer or stop spraying.● Do not use components rated less than system <i>Maximum Working Pressure</i>	   
<p>Never allow children to use this unit. If you are injured using this equipment, get immediate medical treatment.</p>	  

Component Identification and Function

202 Main hose
 203 Whip end hose
 204 Contractor gun with RAC IV
 DripLess tip guard and 517 size SwitchTip

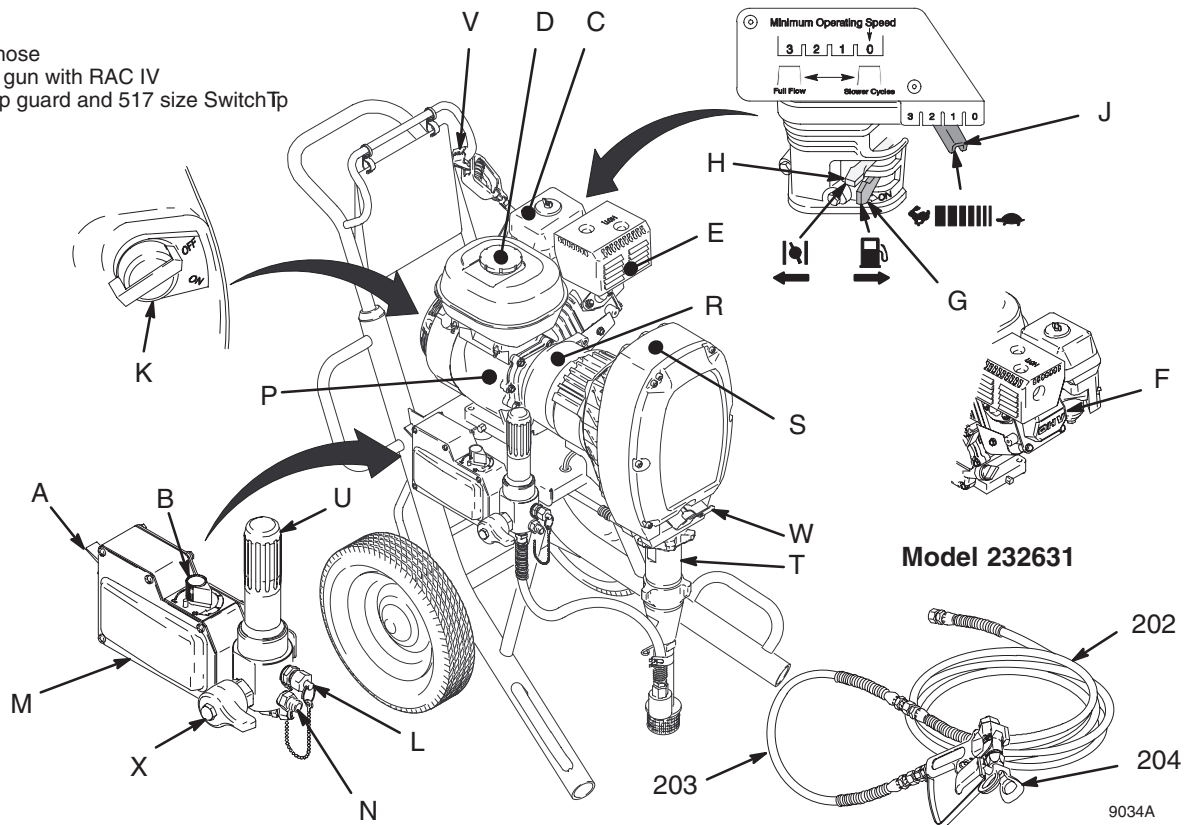

Fig. 1

A	Pressure Control Switch	ON/OFF, enables/disables clutch function and pressure control
B	Pressure Adjusting Knob	Controls fluid outlet pressure
C	Air Cleaner*	Filters air entering the carburetor
D	Fuel Tank*	Uses 86 octane unleaded gasoline
E	Muffler*	Reduces noise of internal combustion
F	Spark Plug Cable*	Routes electrical current to spark plug
G	Fuel Shutoff Lever*	On/off lever to regulate fuel flow from gasoline tank to carburetor
H	Choke*	Enriches air/gasoline mixture for cold starting
J	Throttle Lever*	Adjusts engine speed for large or small orifice spray tips
K	Engine Switch*	Enables/disables engine operation
L	Secondary Fluid Outlet	Second hose and spray gun is connected here
M	Pressure Control	Controls clutch cycling to maintain fluid pressure.
N	Primary Fluid Outlet	Hose and spray gun is connected here
P	Engine*	4-cycle gasoline engine
R	Clutch Housing	Transfers power from engine to drive assembly
S	Drive Housing	Transfers power from clutch to displacement pump
T	Displacement Pump	Provides fluid to be sprayed through spray gun
U	Fluid Filter	Filters fluid between source and spray gun
V	Grounding Clamp and Wire	Grounds sprayer system
W	Pail Hanger	Provides a hanger for paint pail
X	Drain Valve	Relieves fluid pressure when open
*	For more detailed explanations of these controls, refer to the Honda Engines Owner's Manual; supplied	

Maintenance

WARNING



INJECTION HAZARD

The system pressure must be manually relieved to prevent the system from starting or spraying accidentally. Fluid under high pressure can be injected through the skin and cause serious injury. To reduce the risk of an injury from injection, splashing fluid, or moving parts, follow the **Pressure Relief Procedure** whenever you:

- are instructed to relieve the pressure,
- stop spraying,
- check or service any of the system equipment,
- or install or clean the spray tip.

Pressure Relief Procedure

1. Lock gun trigger safety.
2. Turn engine ON/OFF switch to OFF.
3. Move pressure control switch to OFF and turn pressure control knob fully counterclockwise.
4. Unlock trigger safety. Hold metal part of gun firmly to side of grounded metal pail, and trigger gun to relieve pressure.
5. Lock gun trigger safety.
6. Open pressure drain valve. Leave valve open until ready to spray again.

If you suspect that the spray tip or hose is completely clogged, or that pressure has not been fully relieved after following the steps above, VERY SLOWLY loosen tip guard retaining nut or hose end coupling to relieve pressure gradually, then loosen completely. Now clear tip or hose.

CAUTION

For detailed engine maintenance and specifications, refer to separate Honda Engines Owner's Manual, supplied.

DAILY: Check engine oil level and fill as necessary.

DAILY: Check hose for wear and damage.

DAILY: Check gun safety for proper operation.

DAILY: Check pressure drain valve for proper operation.

DAILY: Check and fill the gas tank.

AFTER THE FIRST 20 HOURS OF OPERATION:

Drain engine oil and refill with clean oil. Reference Honda Engines Owner's Manual for correct oil viscosity.

WEEKLY: Remove air filter cover and clean element. Replace element, if necessary. If operating in an unusually dusty environment: check filter daily and replace, if necessary.

Replacement elements can be purchased from your local HONDA dealer.

WEEKLY: Check level of TSL in displacement pump packing nut. Fill nut, if necessary. Keep TSL in nut to help prevent fluid buildup on piston rod and premature wear of packings.

AFTER EACH 100 HOURS OF OPERATION:

Change engine oil. Reference Honda Engines Owner's Manual for correct oil viscosity.

SPARK PLUG: Use only BPR6ES (NGK) or W20EPR-U (NIPPONDENSO) plug. Gap plug to 0.028 to 0.031 in. (0.7 to 0.8 mm). Use spark plug wrench when installing and removing plug.

Troubleshooting

WARNING



INJECTION HAZARD

To reduce risk of serious injury, including fluid injection or splashing in eyes or on skin, or injury from moving parts, always follow **Pressure Relief Procedure Warning**, page 4, before checking, adjusting, cleaning or shutting down sprayer.

PROBLEM	CAUSE	SOLUTION
Engine won't start	Engine switch is OFF	Turn engine switch ON
	Engine is out of gas	Refill gas tank. Honda Engines Owner's Manual.
	Engine oil level is low	Try to start engine. Replenish oil, if necessary. Honda Engines Owner's Manual.
	Spark plug cable is disconnected or damaged	Connect spark plug cable or replace spark plug
	Cold engine	Use choke
	Fuel shutoff lever is OFF	Move lever to ON position
	Oil is seeping into combustion chamber	Remove spark plug. Pull starter rope 3 or 4 times. Clean or replace spark plug. Try to start engine. Keep sprayer upright to avoid oil seepage.
Engine operates, but displacement pump does not operate	Pressure control switch is OFF	Turn pressure control switch ON.
	Pressure setting is too low	Turn pressure adjusting knob clockwise to increase pressure.
	Fluid filter (318) is dirty	Clean filter. Page 22.
	Tip or tip filter is clogged	Clean tip or tip filter. Manual 307614.
	Displacement pump piston rod is stuck due to dried paint	Repair pump. Manual 308798.
	Roller bearings are worn or damaged	Replace connecting rod. Page 7.
	Drive housing is worn or damaged	Replace drive housing. Page 7.
	Electrical power is not energizing clutch field	Check wiring connections. Page 11. Reference control board diagnostics. Page 14. With pressure control switch ON and pressure turned to MAXIMUM, use a test light to check for power between clutch terminals on control board. Remove black clutch wires from control board and measure resistance across wires. At 70° F, the resistance must be between $1.7 \pm 0.2\Omega$; if not, replace clutch coil 241121. Check control board fuse. If blown, replace with equivalent automotive fuse. Have pressure control checked by authorized Graco dealer.
	Clutch is worn or damaged	Replace clutch. Page 9.
Pinion assembly is worn or damaged	Repair or replace pinion assembly. Page 9.	

PROBLEM	CAUSE	SOLUTION
Pump output is low	Strainer (31) is clogged	Clean strainer
	Piston ball (25) is not seating	Service piston ball. Manual 308798.
	Piston packings are worn or damaged	Replace packings. Manual 308798.
	O-ring (227) in displacement pump is worn or damaged	Replace o-ring. Manual 308798.
	Intake valve ball is not seating properly	Clean intake valve. manual 308798.
	Engine speed is too low	Increase throttle setting. Manual 308867.
	Clutch is worn or damaged	Replace clutch. Page 9.
	Pressure setting is too low	Increase pressure. Manual 308867.
	Fluid filter (318), tip filter or tip is clogged or dirty	Clean filter. Manual 308867 or 307614.
	Large pressure drop in hose with heavy materials	Use larger diameter hose and/or reduce overall length of hose. Use of more than 100 ft of 1/4 in. hose significantly reduces performance of sprayer. Use 3/8 in. hose for optimum performance (50 ft minimum).
Excessive paint leakage into throat packing nut	Throat packing nut is loose	Remove throat packing nut spacer. Tighten throat packing nut just enough to stop leakage.
	Throat packings are worn or damaged	Replace packings. Manual 308798.
	Displacement rod is worn or damaged	Replace rod. Manual 308798.
Fluid is spitting from gun	Air in pump or hose	Check and tighten all fluid connections. Reprime pump. Manual 308867.
	Tip is partially clogged	Clear tip. Manual 307614.
	Fluid supply is low or empty	Refill fluid supply. Prime pump. Manual 308867. Check fluid supply often to prevent running pump dry.
Pump is difficult to prime	Air in pump or hose	Check and tighten all fluid connections. Reduce engine speed and cycle pump as slowly as possible during priming.
	Intake valve is leaking	Clean intake valve. Be sure ball seat is not nicked or worn and that ball seats well. Reassemble valve.
	Pump packings are worn	Replace pump packings. Manual 308798.
	Paint is too thick	Thin the paint according to the supplier's recommendations
	Engine speed is too high	Decrease throttle setting before priming pump. Manual 308867.
Clutch squeaks each time clutch engages	Clutch surfaces are not matched to each other when new and may cause noise	Clutch surfaces need to wear into each other. Noise will dissipate after a day of run time
Engine stalls	Engine speed is too slow	<ul style="list-style-type: none"> • Increase throttle setting • Adjust engine speed at no load to 3750 – 3850 rpm
	Fluid filter is clogged	Relieve pressure and clean filter
	Too much pump friction (new pump)	Reduce pressure to 3000 psi until pump wears in
	Spark plug wire is loose	Reconnect wire

Rollers

Removal

1.  Relieve pressure; page 4.
2. Fig. 2. Remove six cap screws (10) lock washers (9) and cover assembly (24).

Note: A screw driver may be needed to pry off cover assembly.

3. Remove dowel pins (97) and rollers (98)

Installation

1. Install rollers (98) and dowel pins (97)
2. Install cover assembly (24) with six lock washers (9) and cap screws (10).

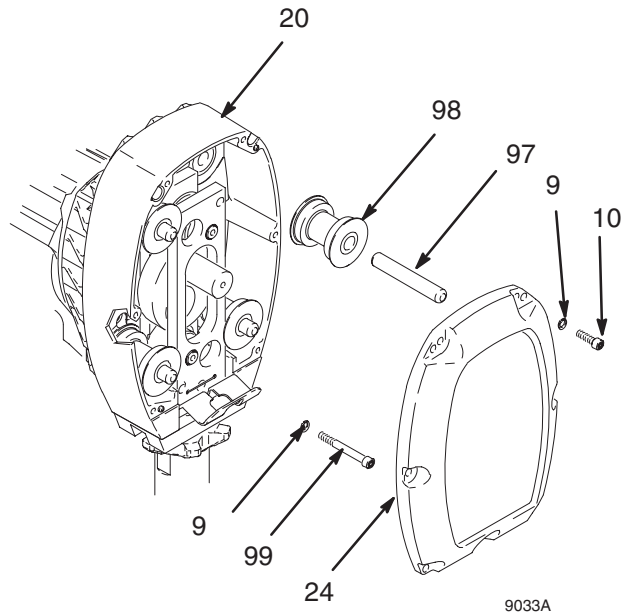



Fig. 2

9033A

Drive Housing

Removal

1.  Relieve pressure; page 4.
2. Fig. 2. Remove six cap screws (10) lock washers (9) and cover assembly (24).
3. Fig. 3. Remove two screws (99) and washers (9).
4. Remove four cap screws (10) lock washers (9) from drive housing (20).
5. Lightly tap around drive housing (20) to loosen drive housing. Pull drive housing straight off pinion housing. Be prepared to support gear cluster (18), which may also come out.

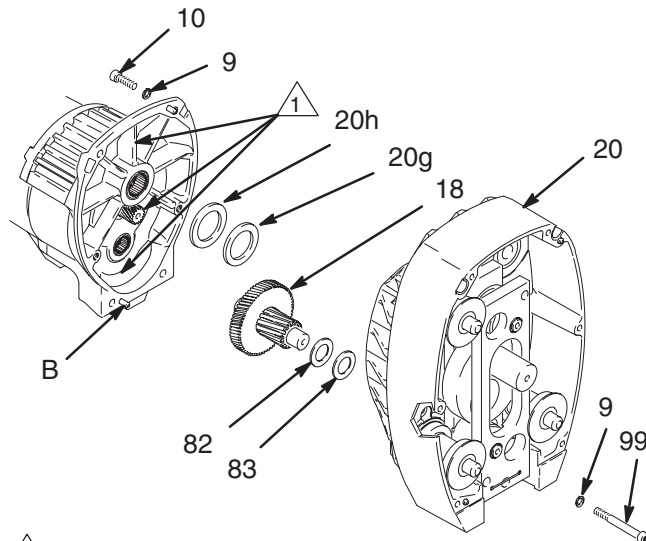

 Apply remaining grease to these areas

Fig. 3

9032A

Installation

1. Liberally apply bearing grease (supplied with replacement gear cluster) to gear cluster (18), washers (82) and (83) and to areas called out by note 1. Use full 0.68 pint (0.32 liter) of grease for GMax 7900.
2. Place bronze colored washer (83) and silver colored washer (82) onto drive housing (20). Install gear cluster (18) through washers (83) and (82).
3. Place bronze colored washer (20g) and silver colored washer (20h) on shaft protruding from large shaft of drive housing (20). Align gears and push new drive housing straight onto pinion housing and locating pins (B).
4. Install two washers (9) and screws (99).
5. Install four lock washers (9) and cap screws (10) into drive housing (20).
6. Install cover assembly (24) with six lock washers (9) and cap screws (10).

Cam Follower Bearings

Removal

1.  Relieve pressure; page 4.
2. Fig. 16. Cycle pump piston rod (222) to lowest position. Turn engine off.
3. Fig. 4. Remove six cap screws (10), lock washers (9) and cover assembly (24).

Note: A screw driver may be needed to pry off cover assembly.

4. Remove four dowel pins (97) and rollers (98).
5. From front, drive out pump pin (101) with a screw driver.
6. Remove two retainer rings (20d).
7. Remove cam follower plate (20b).

Note: Two 1/2 in. x 13 bolts may be needed to remove cam follower plates.

8. Remove two cam follower bearings (20c).

Installation

1. Install two cam follower bearings (20c).
2. Install cam follower plate (20b).
3. Install two retainer rings (20d).
4. Drive in pump pin (101) until it engages with pump pin retaining clip (20a).
5. Install four rollers (98) and dowel pins (97).
6. Install cover assembly (24) with six lock washers (9) and cap screws (10).

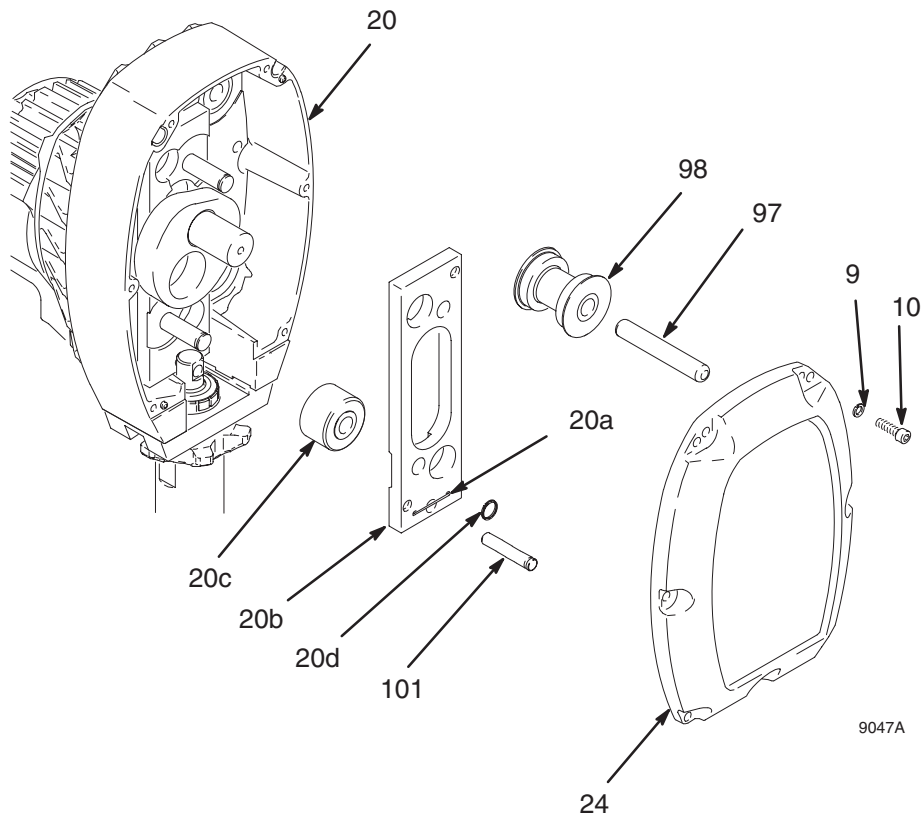

Fig. 4

Pinion Assembly/Rotor/Field/Shaft/Clutch

Removal

If pinion assembly (19) is not removed from clutch housing (5), do 1. through 4. Otherwise, start at 5.

1.  Relieve pressure; page 4.

2. Disconnect field cable (X) from pressure control and engine lead.

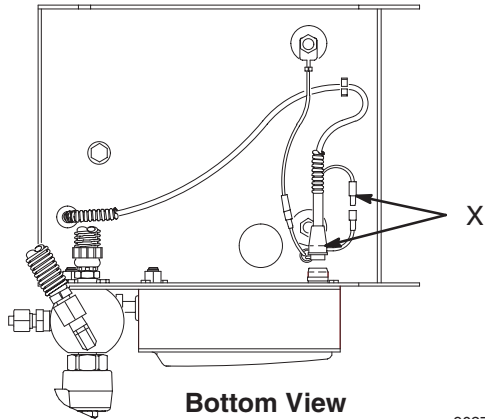

Fig. 5 9027A

3. Fig. 6. Remove five screws (26) and lockwashers (17) and pinion assembly (19).

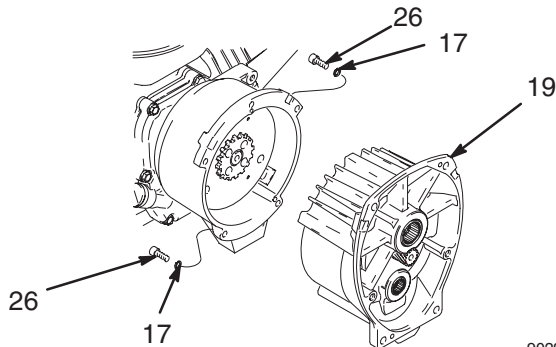

Fig. 6 9029A

4. Fig. 7. Place pinion assembly (19) on bench with rotor side up.
5. Remove four screws (72) and lockwashers (17). Install two screws in threaded holes (E) in rotor. Alternately tighten screws until rotor comes off.

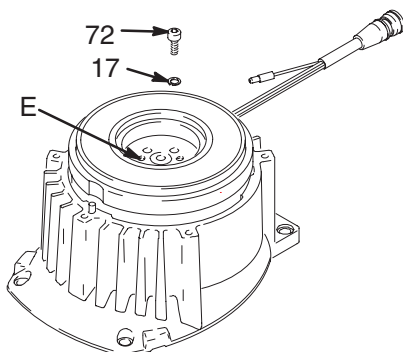

Fig. 7 9030A

6. Fig. 8. Remove retaining ring (19e).
7. Tap pinion shaft (19d) out with plastic mallet.

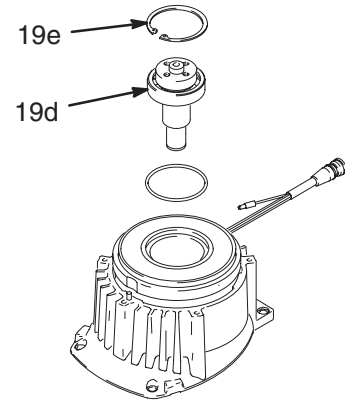

Fig. 8 9031A

8. Fig.9. Use an impact wrench or wedge something between armature (4a) and clutch housing to hold engine shaft during removal.
9. Remove four screws (16) and lockwashers (17).
10. Remove armature (4a).

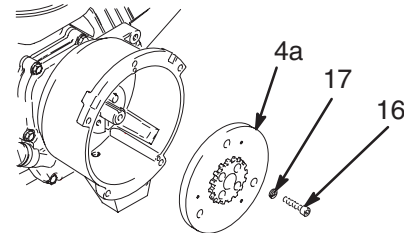

Fig. 9 9028A

Pinion Assembly/Rotor/Field/Shaft/Clutch

Installation

1. Fig. 10. Lay two stacks of two dimes on smooth bench surface.
2. Lay armature (4a) on two stacks of dimes.
3. Press center of clutch down on bench surface.

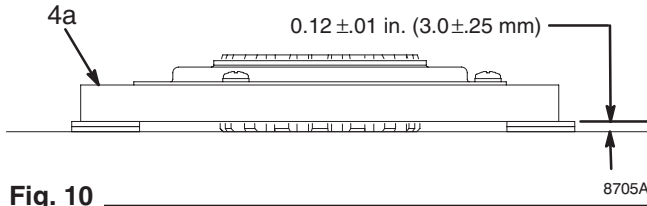

Fig. 10

4. Install armature (4a) on engine drive shaft.
5. Install four screws (16) and lockwashers (17) with torque of 125 in-lb.

6. Fig. 8. Tap pinion shaft (19d) in with plastic mallet.
7. Install retaining ring (19e) with beveled side facing field (Y).
8. Fig. 7. Place pinion assembly on bench with rotor side up.
9. Apply locktite to screws. Install four screws (16) and lockwashers (17). Alternately torque screws to 125 in-lb until rotor is secure. Use threaded holes to hold rotor.
10. Fig. 6. Install pinion assembly (19) with five screws (10) and lockwashers (9).
11. Fig. 5. Connect field cable (X) to pressure control and engine lead.

Clamp

Removal

1. Fig. 11. Loosen two screws (16) on clamp (8),
2. Push screwdriver into slot in clamp (8) and remove clamp.

Installation

1. Fig. 11. Install engine shaft key (7).
2. Tap clamp (8) on engine shaft (A) with plastic mallet.
3. Press clamp (8) onto engine shaft (A). Maintain dimension shown note 2 in Fig. 11. Chamfer side must face engine.

Check dimension: Place rigid, straight steel bar (B) across face of clutch housing (5). Use accurate measuring device to measure distance between bar and face of clamp. Adjust clamp as necessary. Torque two screws (16) to 125 ± 10 in-lb (14 ± 1.1 N·m).

- ① Face of clutch housing
- ② 1.812 ± 0.010 in. (46.02 ± 0.25 mm)
- ③ Torque to 125 ± 10 in-lb (14 ± 1.1 N·m)
- ④ Chamfer this side

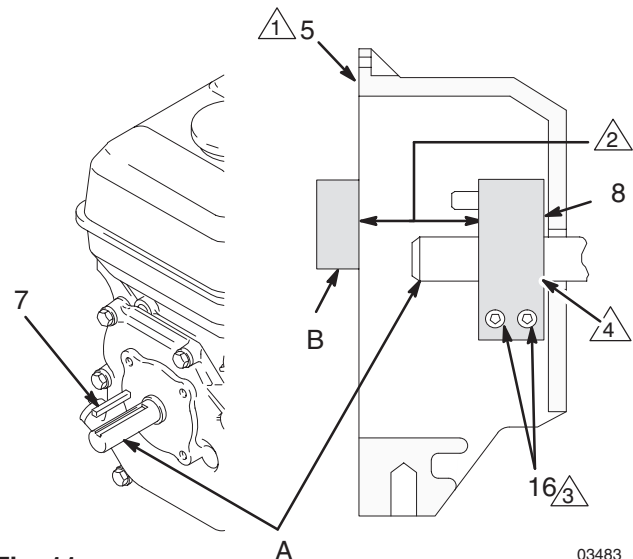

Fig. 11

03483

Clutch Housing

Removal

1. Fig. 12. Remove four capscrews (75) and lockwashers (77) which hold clutch housing (5) to engine.
2. Remove screw (15) from under mounting plate (D).
3. Remove engine key (7).
4. Pull off clutch housing (5).

Installation

1. Fig. 12. Push on clutch housing (5).
2. Install four capscrews (75) and lockwashers (77) and secure clutch housing (5) to engine. Torque to 200 in-lb (22.6 N•m).
3. Install capscrew (15) from beneath mounting plate (D). Torque to 26 ft-lb (35.2 N•m).

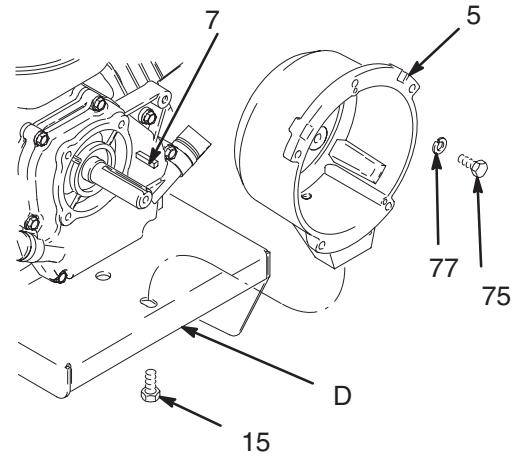

Fig. 12

9025A

Engine

Removal

1. Remove **Pinion Assembly/Rotor/Field/Pinion/Clutch, Clamp** and **Clutch Housing**, as instructed on pages 7, 9 and 10.
2. Fig. 13. Disconnect all necessary wiring.
3. Fig. 14. Remove two locknuts (71) and screws (70) from base of engine.
4. Lift engine carefully and place on work bench.

NOTE: All service to the engine must be performed by an authorized HONDA dealer.

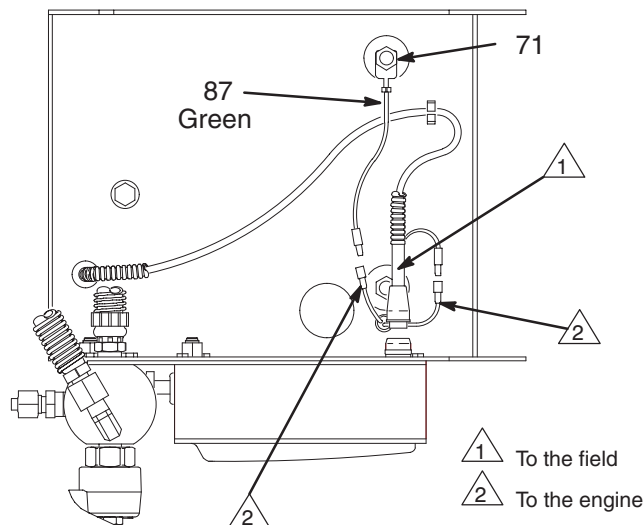

Fig. 13

9027A

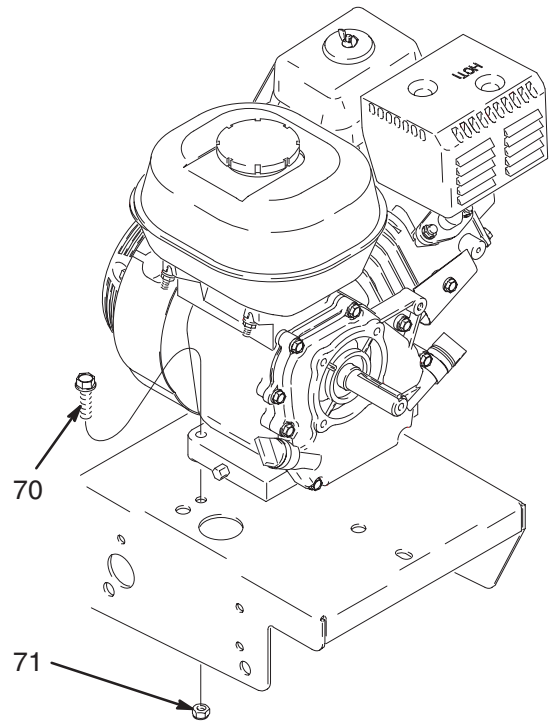

Fig. 14

9026A

Installation

1. Lift engine carefully and place on cart.
2. Fig. 14. Install two screws (70) in base of engine and secure with locknuts (71). Torque to 200 in-lb (22.6 N•m).
3. Fig. 13. Connect all necessary wiring.
4. Install **Pinion Assembly/Rotor/Field/Pinion/Clutch, Clamp** and **Clutch Housing**, as instructed on pages 7, 9 and 10.

On/Off Switch

Removal

1.  Relieve pressure; page 4.
2. Fig. 15. Remove five screws (307) and cover (322).
3. Disconnect two wires (A) from ON/OFF switch (309).
4. Press in on two retaining tabs on each side of ON/OFF switch (309) and remove switch.

Installation

1. Install new ON/OFF switch (309) so tabs of switch snap into place on inside of pressure control housing.
2. Connect two wires (A) to ON/OFF switch.
3. Install pressure control cover (322) with five screws (307).

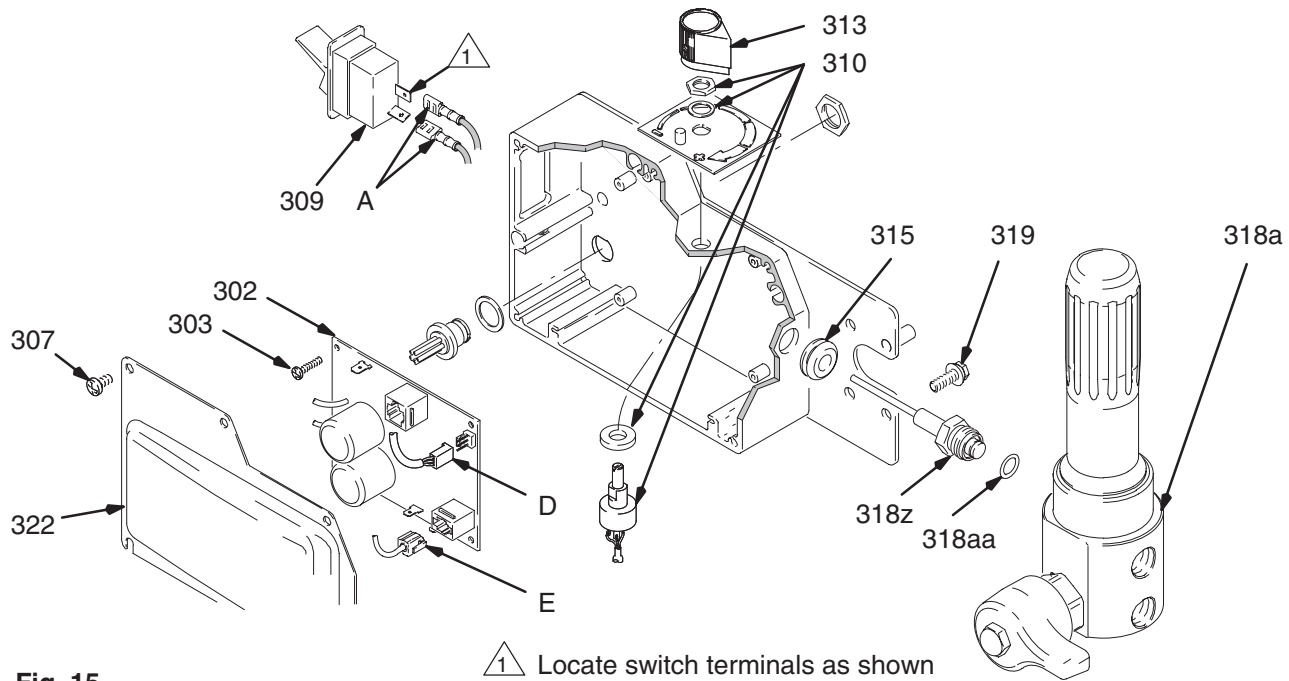

8711A

Fig. 15

Pressure Control

Control Board

Removal

-  Relieve pressure; page 4.
- Fig. 15. Remove five screws (307) and cover (322).
- Fig. 22. Disconnect at control board (302):
 - Four clutch leads: two violet and two black.
 - Lead (D) from potentiometer.
 - Lead (E) from transducer.
 - Two red leads (A) to ON/OFF switch (309).
- Fig. 15. Remove five screws (303), green ground wire and control board (302).

Installation

When installing replacement control board, follow instructions with control board to set model type.

- Fig. 15. Install green ground wire and control board (302) with five screws (303).
- Fig. 22. Connect to control board (302):
 - Two red leads (A) to ON/OFF switch (309).
 - Lead (E) to transducer.
 - Lead (D) to potentiometer.
 - Four clutch leads: two violet and two black.
- Fig. 15. Install cover (322) with five screws (307).

Pressure Control Transducer

Removal

-  Relieve pressure; page 4.
- Fig. 15. Remove five screws (307) and cover (322).
- Disconnect lead (E) from control board (302).
- Remove three screws (319) and fluid filter (318) from control plate (301). Carefully pull transducer connector through rubber grommet (315).

- Remove pressure control transducer (318z) and packing o-ring (318aa) from filter housing (318a).

Installation

- Fig. 15. Install packing o-ring (318aa) and pressure control transducer (318z) in filter housing (318a). Torque to 30–35 ft-lb.
- Carefully feed transducer connector through rubber grommet (315). Install fluid filter (318) on control plate (301) with three screws (319).
- Connect lead (E) to motor control board (302).
- Install cover (322) with five screws (307).

Pressure Adjust Potentiometer

Removal

-  Relieve pressure; page 4.
- Fig. 15. Remove five screws (307) and cover (322).
- Disconnect lead (D) from control board (302).
- Loosen set screws on potentiometer knob (313) and remove knob, shaft nut, lockwasher (310) and pressure adjust potentiometer (310).
- Remove seal (311) from potentiometer (310).

Installation

- Install seal (311) on potentiometer (310).
- Fig. 15. Install pressure adjust potentiometer (310), shaft nut, lockwasher (310) and potentiometer knob (313).
 - Turn potentiometer shaft (310) clockwise to internal stop. Assemble potentiometer knob (313) to strike pin on plate (312).
 - After adjustment of step a., tighten both set screws in knob 1/4 to 3/8 turn after contact with shaft.
- Connect lead (D) to control board (302).
- Install cover (322) with five screws (307).

Pressure Control

Control Board Diagnostics

1. Fig. 15. Remove five screws (307) and cover (322).
2. Start sprayer.
3. Turn ON/OFF switch ON.
4. Observe LED operation and reference following table:

LED BLINKS	SPRAYER OPERATION	INDICATES	WHAT TO DO
Two times repeatedly	Sprayer shuts down and LED continues to blink two times repeatedly	Run away pressure. Pressure greater than 4500 psi (310 bar, 31 MPa).	<ol style="list-style-type: none"> 1. Check pressure transducer connection at control board 2. Replace pressure transducer 3. Replace control board
Three times repeatedly	Sprayer shuts down and LED continues to blink three times repeatedly	Pressure transducer is faulty or missing	<ol style="list-style-type: none"> 1. Check pressure transducer connection at control board 2. Replace pressure transducer 3. Replace control board
Four times repeatedly	Sprayer shuts down and LED continues to blink four times repeatedly	Generator voltage is low	<ol style="list-style-type: none"> 1. Increase engine throttle 2. Check wiring connections 3. Service Honda engine alternator
Five times repeatedly	Sprayer shuts down and LED continues to blink five times repeatedly	High clutch current	<ol style="list-style-type: none"> 1. Check clutch 5-pin bulkhead connector. Clean contacts. 2. Measure $1.7 \pm 0.2\Omega$ across clutch field at 70°F 3. Replace clutch field assembly
Six times repeatedly	Sprayer shuts down and LED continues to blink six times repeatedly	High clutch temperature	<ol style="list-style-type: none"> 1. If clutch is new, let sprayer cool down and then restart 2. Inspect clutch. Replace clutch if there is excessive wear. 3. Remove pump pin, separate pinion housing from clutch housing. Rotate rotor clockwise to check for excessive drag.

Displacement Pump

Removal

1. Flush pump.
2. Fig. 16. Cycle pump with piston rod (222) in lowest position.
3.  Relieve pressure; page 4.
4. Fig. 16. Remove suction tube (30) and hose (33).

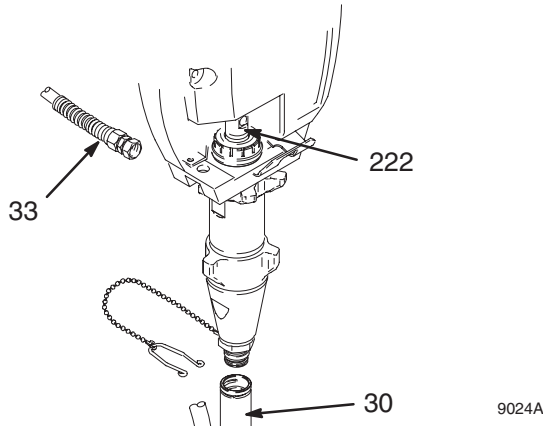

Fig. 16

9024A

Repair

See manual 308798 for pump repair instructions.

Installation

WARNING

If pin works loose, parts could break off due to force of pumping action. Parts could project through the air and result in serious injury or property damage. Make sure pin (101) and retaining clip (230) are properly installed. Clip must engage groove in pin.

CAUTION

If the pump locknut loosens during operation, the threads of the bearing housing will be damaged. Make sure locknut is properly tightened.

1. Fig. 19. Pull piston rod out 1.0 in. Screw in pump until holes in housing plates and piston rod align.

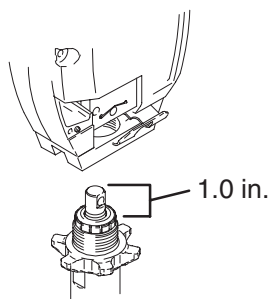

Fig. 19

9020A

5. Fig. 17. Use screwdriver to push out pump pin (101).

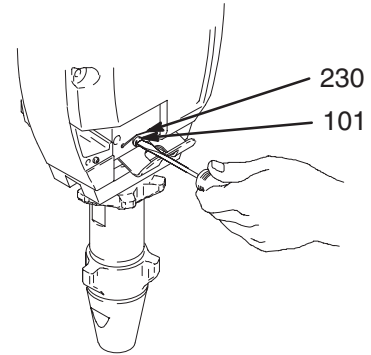

Fig. 17

9019A

6. Fig. 18. Loosen locknut by hitting firmly with a 20 oz (maximum) hammer. Unscrew pump.

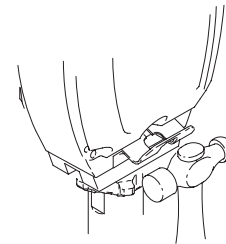

Fig. 18

9022A

2. Fig. 17. Push pin (101) into hole until retaining clip (230) engages pump pin groove.

Fig. 20. Screw jam nut down onto pump until nut stops. Screw pump up into pump plate until it stops. Back off pump one full turn and align pump outlet to back. Tighten jam nut by hand, then tap 1/8 to 1/4 turn with a 20 oz (maximum) hammer to approximately 75 ± 5 ft-lb (102 N-m).

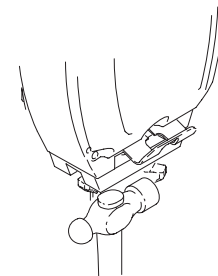

Fig. 20

9021A

- Fig. 21. Fill packing nut with Graco TSL until fluid flows onto the top of seal.

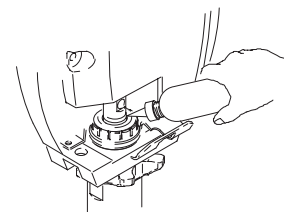

Fig. 21

9023A

Displacement Pump

Pump Pin Clip

Removal

1. Remove pump (28).
2. Remove two bolts (86), washers (25), pump bracket (85), pail hook (94) and shield (95).
3. Fig. 17. Remove clip (230).

Installation

1. Fig. 17. Install clip (230).
2. Install shield (95), pail hook (94) and pump bracket (85) with two washers (25) and bolts (86). Torque bolts to 40 ft-lb (54 N•m).
3. Install pump (28).

Parts List & Drawing – Pinion Assembly

Ref No. 19 and 20

Ref No. 19: Pinion Housing Assembly 241116

Ref No. 20: Drive Housing Assembly 241537

Ref No.	Part No.	Description	Qty	Ref No.	Part No.	Description	Qty
19a	241121	PINION HOUSING, COIL	1	20		DRIVE HOUSING	1
19b	105489	PIN	2	20a	194060	RETAINING CLIP, pump pin	1
19d	241114	PINION SHAFT		20b	193656	CAM FOLLOWER PLATE	1
19e	112770	RETAINING RING, large		20c	114691	CAM FOLLOWER BEARING	2
				20d	114828	RETAINER CLIP	2
				20g	114697	WASHER	1
				20h	114698	WASHER	1
				101	194117	PIN	1

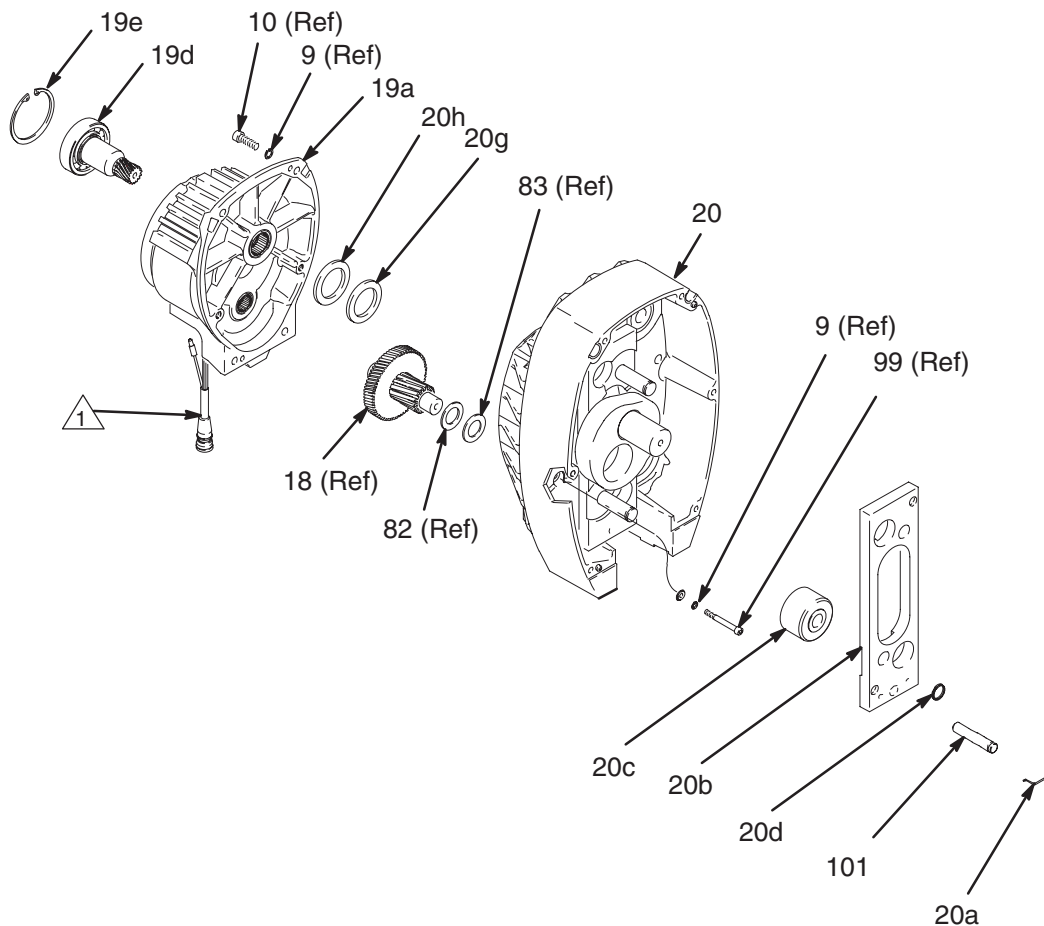

△ Pinion housing/coil assembly (19a) includes clutch field and all bearings, pins and o-rings

9046A

Parts Drawing – Hi-Boy Sprayers

Model 232630

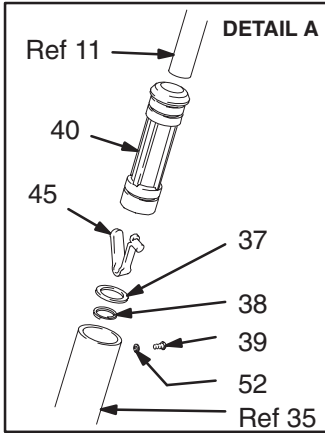

- 1 Label
- 2 See page 17 for the parts.
- 3 See manual 308798 for the parts.
- 4 See page 22 for the parts.
- 5 See page 22 for the parts.

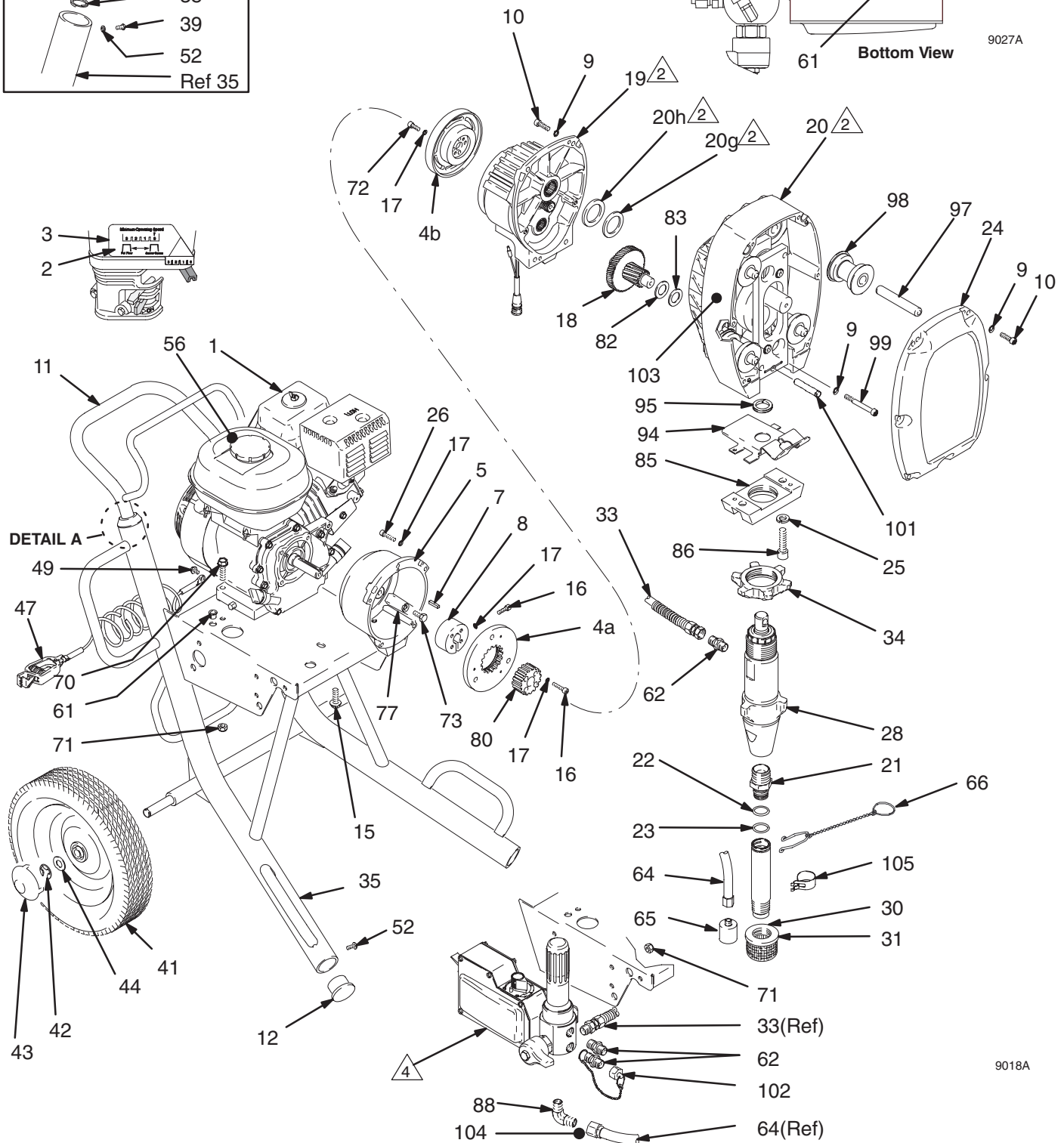
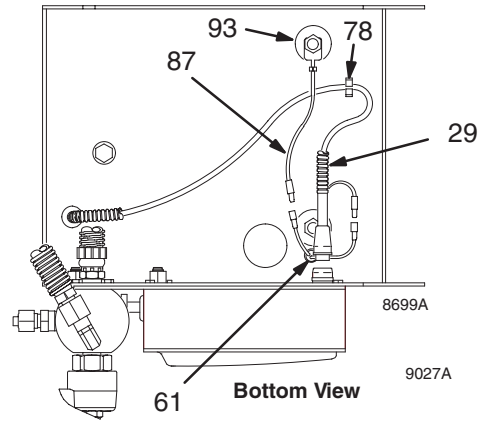

9018A

Parts List – Hi-Boy Sprayers

Models 232630

Ref No.	Part No.	Description	Qty	Ref No.	Part No.	Description	Qty
1	114530	ENGINE	1	41	179811	WHEEL, semi-pneumatic	2
2	113084	RIVET, blind	2	42	101242	RING, retaining	2
3	192014	PLATE, indicator	1	43	104811	HUBCAP	2
4	241113	CLUTCH ASSEMBLY , includes 4a, 4b, 16, 17, 72, 80	1	44	154636	WASHER	2
4a		.ARMATURE, clutch, 5 in.	1	45	112827	BUTTON, snap	2
4b		.ROTOR, 5 in.	1	47	237686	GROUNDING CLAMP & WIRE	1
5	193531	CLUTCH HOUSING	1	49	112798	SCREW, hex washer hd, No. 8 x 3/8 in	1
7	183401	KEY, parallel	1	52	114984	SCREW, mch, pn hd;	2
8	193680	CLAMP	1	56▲	194126	LABEL, warning	1
9	104008	WASHER, spring, lock	12	61	114678	BUSHING, strain relief	1
10	101864	CAPSCREW, socket head, 1/4–20 x 3/4 in.	10	62	162485	NIPPLE, 3/8–18 npsm(m) x 3/8 npt(m)	3
11	239998	CART HANDLE & HOSE RACK	1	64	194178	HOSE, drain	1
12	193682	CAP, end	2	65	241718	DEFLECTOR	1
15	113802	SCREW, flange, hex hd, 3/8–16 x 5/8 in.	1	66	241719	CLIP, spring	1
16	108803	CAPSCREW, sch, 1/4–2 x 1 in.	6	70	110837	SCREW, flng, hex hd, 5/16–18 x 1–1/2 in.	2
17	105510	LOCKWASHER, spring, 1/4 in.	15	71	110838	LOCKNUT, heavy hex, 5/16–18	6
18	241539	GEAR COMBINATION includes 91 and 92	1	72	101682	SCREW, cap, sch	4
19	241116	PINION ASSEMBLY ; Parts, page 17	1	73	108842	SCREW, cap, sch	4
20	241537	DRIVE HOUSING ; Parts, page 17	1	77	100214	WASHER, lock, spring	4
21	194189	SWIVEL, male, QD	1	78	114687	CLIP, retainer	1
22	103413	O-RING	1	80	80	HUB, armature	1
23	111603	O-RING	1	82	114699	WASHER, thrust	1
24	241536	COVER, housing, drive, kit	1	83	114672	WASHER, thrust	1
25	100018	WASHER, lock, spring	1	85	194118	BRACKET, pump	1
26	100644	SCREW, cap	5	86	110343	SCREW, cap, sch	2
28	240917	DISPLACEMENT PUMP Parts, manual 308798	1	87	240997	CONDUCTOR, ground	1
29	194438	TUBE, nylon, split	1	88	110249	ADAPTER, male elbow, 90°	1
30	241541	TUBE, intake includes 22, 23, and 66	1	93	108851	WASHER	2
31	189920	STRAINER	1	94	241540	PAIL HOOK Repair Kit; includes 95	1
33	240795	HOSE, coupled	1	95	195377	GROMMET, pump	1
34	193394	NUT, retaining	1	96	206994	THROAT SEAL LIQUID; not shown	1
35	241324	CART FRAME	1	97	114695	DOWEL PIN	4
37	183350	WASHER, plain	2	98	241322	ROLLER assembly	4
38	110243	RING, retaining	2	99	114693	SCREW, cap, sch	2
39	108795	SCREW, mch, pn hd, 10–32 x 5/16 in.	4	101	194117	PIN	1
40	191084	SLEEVE	2	102	240987	PLUG, packless, 3/8 in.	1
				103▲	194317	LABEL, warning	1
				104▲	195119	LABEL, warning; not shown	1
				105	194194	CLIP, spring.	1

▲ Danger & Warning labels, tags, and cards are free.

Parts Drawing – Lo-Boy Sprayers

Model 232632

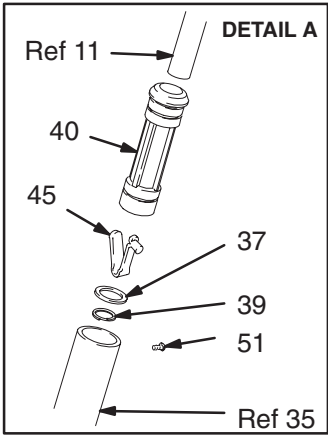

- 1 Label
- 2 See page 17 for the parts.
- 3 See manual 308798 for the parts.
- 4 See page 22 for the parts.

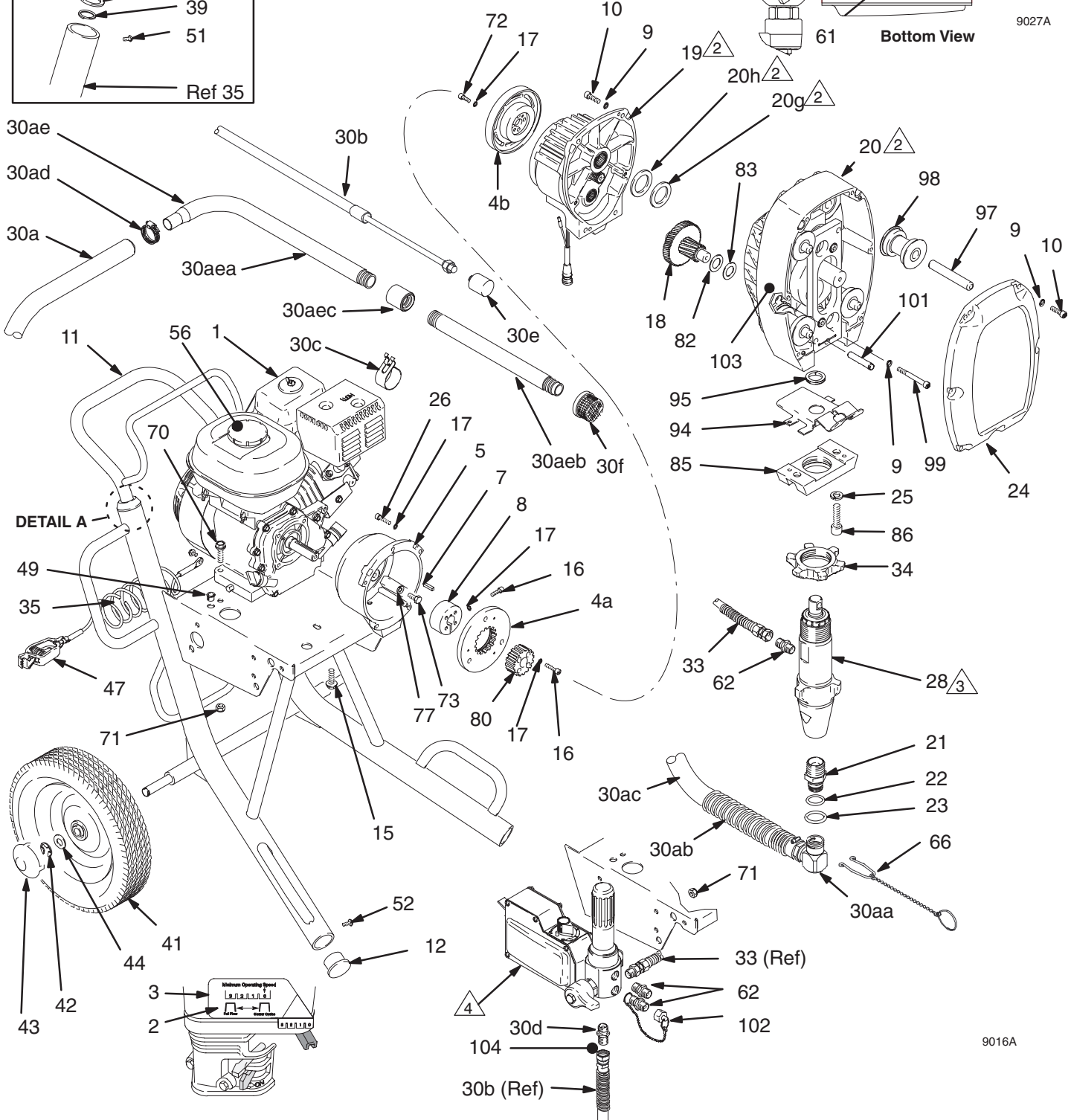
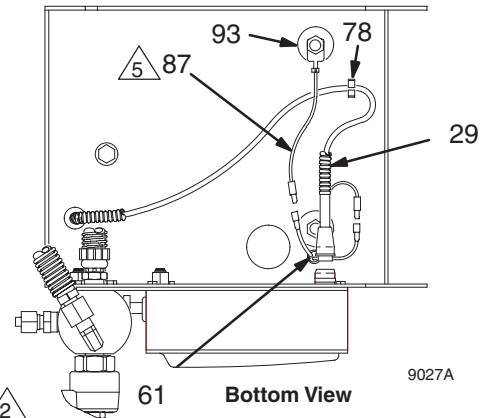

Parts List – Lo-Boy Sprayers

Model 232632

Ref No.	Part No.	Description	Qty	Ref No.	Part No.	Description	Qty
1	114530	ENGINE	1	30f	112604	.STRAINER	1
2	113084	RIVET, blind	2	33	240795	HOSE, coupled	1
3	192014	PLATE, indicator	1	34	193394	NUT, retaining	1
4	241113	CLUTCH ASSEMBLY , includes 4a, 4b, 16, 17, 72, 80	1	35	241324	CART FRAME	1
4a		.ARMATURE, clutch, 5 in.	1	37	183350	WASHER, plain	2
4b		.ROTOR, 5 in.	1	38	110243	RING, retaining	2
5	193531	CLUTCH HOUSING	1	39	108795	SCREW, mch, pn hd, 10–32 x 5/16 in.	4
7	183401	KEY, parallel	1	40	191084	SLEEVE	1
8	193680	CLAMP	1	41	179811	WHEEL, semi–pneumatic	1
9	104008	WASHER, spring, lock	12	42	101242	RING, retaining	2
10	101864	CAPSCREW, socket head, 1/4–20 x 3/4 in.	10	43	104811	HUBCAP	2
				44	154636	WASHER	2
				45	112827	BUTTON, snap	2
11	239998	CART HANDLE & HOSE RACK	1	47	237686	GROUNDING CLAMP & WIRE	1
12	193682	CAP, end	2	49	112798	SCREW, hex washer hd, No. 8 x 3/8 in	1
15	113802	SCREW, flange, hex hd, 3/8–16 x 5/8 in.	1	52	114984	SCREW, mch, pn hd;	2
				56▲	194126	LABEL, warning	1
16	108803	CAPSCREW, sch, 1/4–2 x 1 in.	6	61	114678	BUSHING, strain relief	1
17	105510	LOCKWASHER, spring, 1/4 in.	15	62	162485	NIPPLE, 3/8–18 npsm(m) x 3/8 npt(m)	3
18	241539	GEAR COMBINATION includes 91 and 92	1	64	194178	HOSE, drain	1
				65	241718	DEFLECTOR	1
19	241116	PINION ASSEMBLY ; Parts, page 17	1	66	241719	CLIP, spring	1
20	241537	DRIVE HOUSING ; Parts, page 17	1	70	110837	SCREW, flng, hex hd, 5/16–18 x 1–1/2 in.	2
21	194189	SWIVEL, male, QD	1				
22	103413	O-RING	1	71	110838	LOCKNUT, heavy hex, 5/16–18	6
23	111603	O-RING	1	72	101682	SCREW, cap, sch	4
24	241536	COVER, housing, drive, kit	1	73	108842	SCREW, cap, sch	4
25	100018	WASHER, lock, spring	1	77	100214	WASHER, lock, spring	4
26	100644	SCREW, cap	5	78	114687	CLIP, retainer	1
28	240917	DISPLACEMENT PUMP Parts, manual 308798	1	80		HUB, armature	1
				82	114699	WASHER, thrust	1
29	194438	TUBE, nylon, split	1	83	114672	WASHER, thrust	1
30	241288	ASSEMBLY, tube, suction	1	85	194118	BRACKET, pump	1
30a	241269	.TUBE, suction, 30 gallon (120 liter) . includes 30aa through 30ae	1	86	110343	SCREW, cap, sch	2
				87	240997	CONDUCTOR, ground	1
30aa	241542	..SWIVEL, tube, inlet includes 22, 23 and 66	1	88	110249	ADAPTER, male elbow, 90°	1
				93	108851	WASHER	2
30ab	176450	..GUARD, hose	1	94	241540	PAIL HOOK Repair Kit; includes 95	1
30ac	194307	..HOSE, fluid	1	95	194681	GROMMET, pump	1
30ad	101818	..CLAMP, hose	2	96	206994	THROAT SEAL LIQUID; not shown	1
30ae	241720	..TUBE, suction includes 30aea, 30aeb and 30aec	1	97	114695	DOWEL PIN	4
				98	241322	ROLLER assembly	4
30aea	170957	...TUBE, suction, lower	1	99	114693	SCREW, cap, sch	2
30aeb	195151	...TUBE, intake.	1	101	194117	PIN	1
30aec	114967	...COUPLING, pipe, 1in.	1	102	240987	PLUG, packless, 3/8 in.	1
30b	194180	.HOSE, drain	1	103▲	194317	LABEL, warning	1
30c	194194	.CLIP, spring	1	104▲	195119	LABEL, warning	1
30d	162453	.NIPPLE	1				
30e	241718	.DEFLECTOR	1				

▲ Danger & Warning labels, tags, and cards are free.

Parts Drawing – Sprayer

Models 232630 through 232633

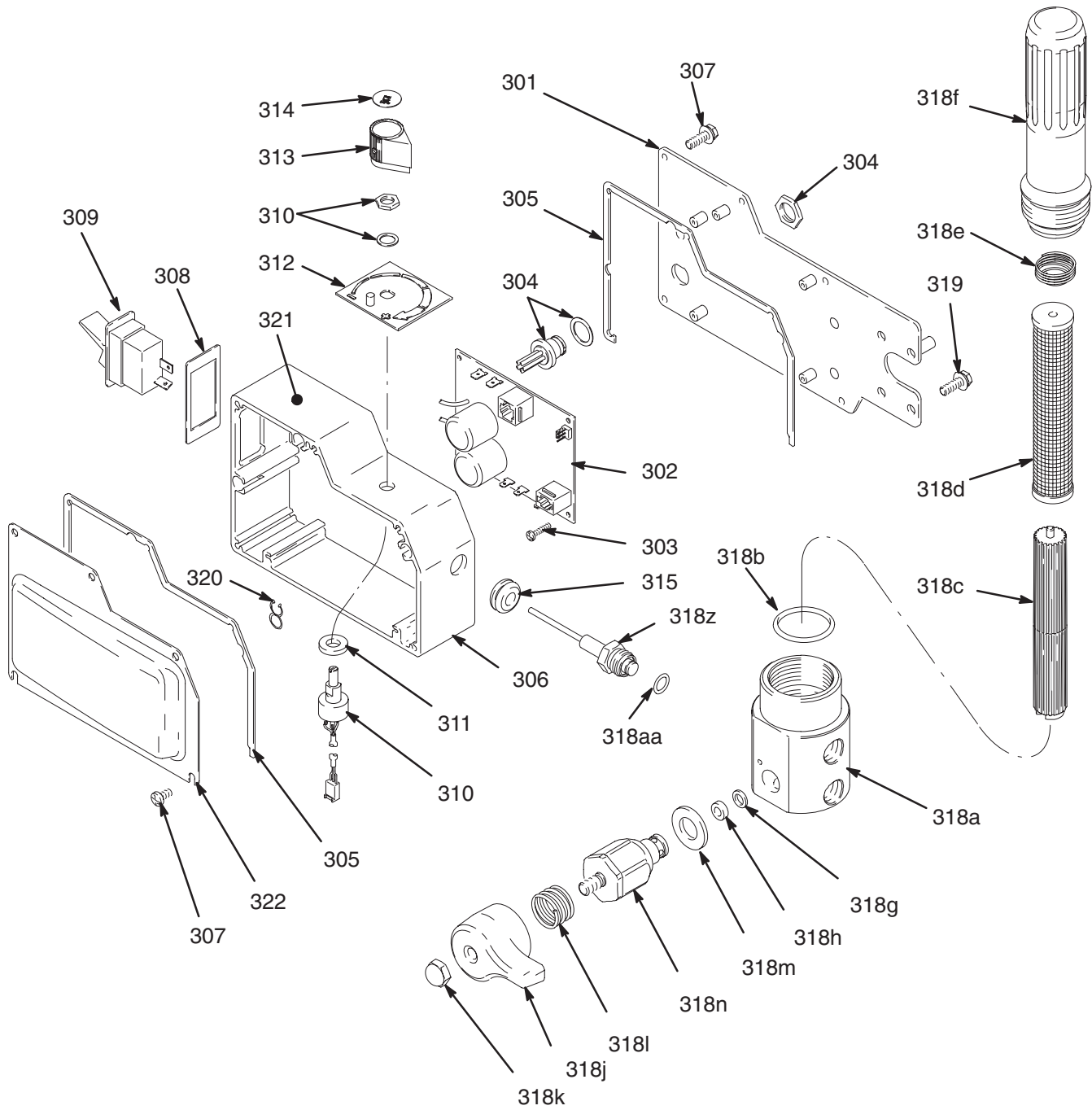

8716A

Parts List – Sprayer

Models 232630 through 232633

REF NO.	PART NO.	DESCRIPTION	QTY	REF NO.	PART NO.	DESCRIPTION	QTY
301	193653	PLA TE, control	1	318e	171941	SPRING, compression	1
302	241093	BOARD, PC	1	318f	192706	BOWL, filter	1
303	111839	SCREW, mch pan, 6–32 x 1/2 in.	5	318g	193710*	SEAL, valve	1
304	240776	HARNES, wiring.	1	318h	193709*	SEA T, valve	1
305	193497	GASKET, control	2	318j	194102*	HANDLE, valve	1
306	193652	HOUSING, control box	1	318k	114688*	NUT, cap, hex hd	1
307	114631	SCREW, mch, pan hd	10	318l	114708*	SPRING, compression	1
308	193052	PLATE, instruction	1	318m	114797*	GASKET	1
309	114277	SWITCH, rocker, (spst)	1	318n	240914*	V ALVE	1
310	241443	POTENTIOMETER, pressure control	1	318z	240314	TRANSDUCER, pressure control includes 318aa	1
311	193657	GASKET, potentiometer	1	318aa	111457	O-RING	1
312	193654	PLATE, instruction	1	319	110997	SCREW, flange, hex	3
313	114273	KNOB, potentiometer	1	320	114532	TIE, wire, twist	1
314	193072	LABEL, control	1	321▲	189246	LABEL, warning	1
315	114629	GROMMET, transducer	1	322	241444	COVER, pressure control	1
318		FILTER, fluid	1				
318a	193651	HOUSING, filter	1				
318b	104361	O-RING	1				
318c	186075	SUPPOR T, filter	1				
318d	167025	STRAINER, mesh, 60	1				

* Drain valve replacement kit 241276 available; includes 318g through 318n
 ▲ Replacement warning labels may be ordered free of charge

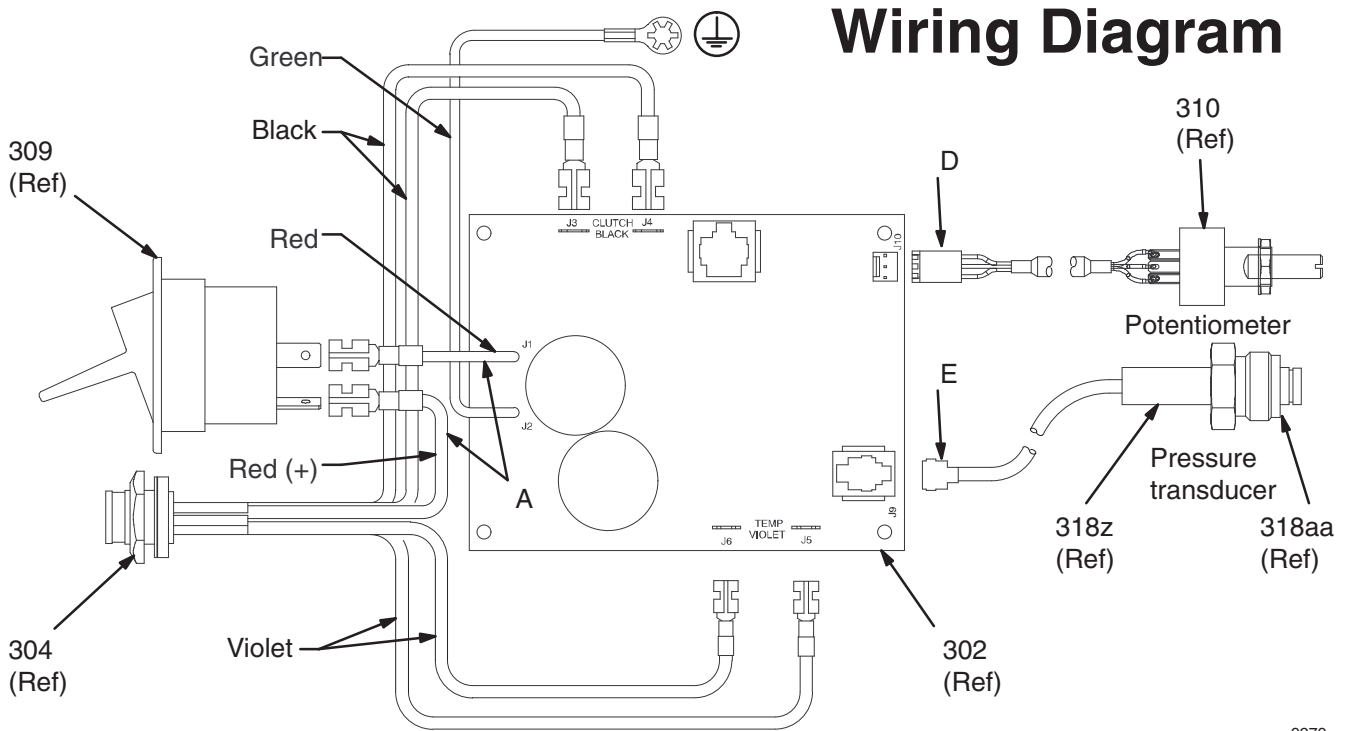

Fig. 22

9279

Parts List & Drawing – Complete Sprayers

Models 232631, 232633

Includes items 201 to 204

Ref No.	Part No.	Description	Qty
201	232631	Hi-Boy Sprayer See parts list on page 18	1
	232633	Lo-Boy Sprayer See parts list on page 21	1
202	240797	HOSE, grounded, nylon; 3/8 in. ID; cpld 3/8 npsm(fbe); 50 foot (15 m); spring guards both ends 3300 psi (227 bar, 27.7 MPa)	1
203	238358	HOSE, grounded, nylon; 3/16 in. ID; cpld 1/4 npsm(m) x 1/4 npsm(f) swivel; 3 foot (0.9 m); spring guards both ends	1
204	220955	CONTRACTOR SPRAY GUN Includes RAC IV™ DripLess™ Tip Guard and 517–size SwitchTip™ See 307614 for parts	1

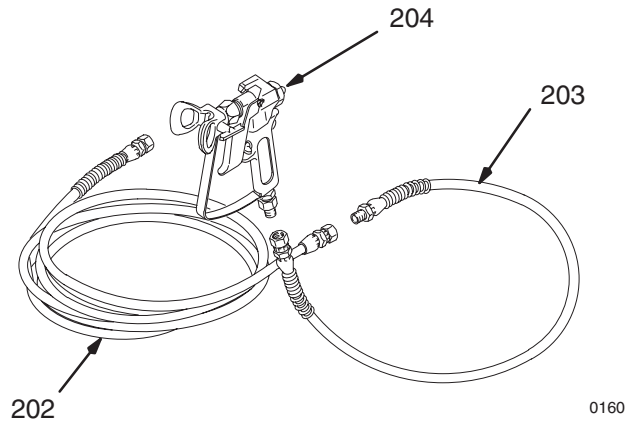

Accessories

DANGER LABELS

An English language DANGER label is on your sprayer. If you have painters who do not read English, order one of the following labels to apply to your sprayer. The drawing shows the best placement of these labels for good visibility.

Order the labels from your Graco distributor.

French	194931
Spanish	194932
German	194933
Greek	194934
Korean	194935
English	194317

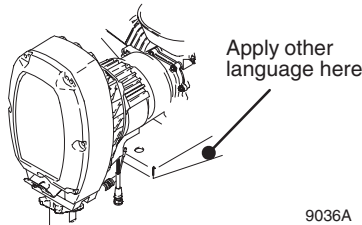

Displacement Pump Repair Kit

Packing repair kit.

GMax 7900

240916

Technical Data

Honda GX160 Engine
 Power Rating @ 3700 rpm
 ANSI 5.5 Horsepower
 DIN 6270B/DIN 6271
 NA 2.9 Kw – 4.0 Ps
 NB 3.6 Kw – 4.9 Ps
 Maximum working pressure 3300 psi
 (227 bar, 22.7 MPa)
 Noise Level
 Sound power 105 dBa
 per ISO 3744
 Sound pressure 96 dBa
 measured at 3.1 feet (1 m)
 Cycles/gallon (liter) 69 (18)

Maximum delivery rating 2.1 gpm (7.9 liter/min)
 Maximum tip size 1 gun with 0.046 in. tip
 2 guns with 0.033 in. tip
 3 guns with 0.026 in. tip
 4 guns with 0.022 in. tip
 Inlet paint strainer16 mesh (1190 micron)
 stainless steel screen, reusable
 Outlet paint filter60 mesh (250 micron)
 stainless steel screen, reusable
 Pump inlet size 3/4 in. npt (m)
 Fluid outlet size 1/4 npsm from fluid filter
 Wetted parts zinc-plated carbon steel,
 PTFE®, Nylon, polyurethane, UHMW polyethylene,
 Viton®, Delrin®, leather, aluminum, tungsten car-
 bide, nickle-plated carbon steel, stainless steel,
 chrome plating

NOTE: Delrin®, PTFE, Viton® are trademarks of the Company.

Dimensions

Model 232630

Hi-Boy without hose or gun

Weight (dry, without packaging) 175 lb (79.4 kg)
 Height 4.1 in. (104.1 cm)
 Length 38 in. (96.5 cm)
 Width 22 in. (55.9 cm)

Model 232632

Lo-Boy Cart without hose or gun

Weight (dry, without packaging) 180 lb (82.1 kg)
 Height 4.1 in. (104.1 cm)
 Length 38 in. (96.5 cm)
 Width 22 in. (55.9 cm)

Graco Phone Number

TO PLACE AN ORDER, contact your Graco distributor, or call this number to identify the distributor closest to you:
1-800-690-2894 Toll Free

Graco Warranty

Graco warrants all equipment manufactured by Graco and bearing its name to be free from defects in material and workmanship on the date of sale by an authorized Graco distributor to the original purchaser for use. With the exception of any special, extended or limited warranty published by Graco, Graco will, for a period of twelve months from the date of sale, repair or replace any part of the equipment determined by Graco to be defective. This warranty applies only when the equipment is installed, operated and maintained in accordance with Graco's written recommendations.

This warranty does not cover, and Graco shall not be liable for general wear and tear or any malfunction, damage or wear caused by faulty installation, misapplication, abrasion, corrosion, inadequate or improper maintenance, negligence, accident, tampering, substitution of non-Graco component parts. Nor shall Graco be liable for malfunction, damage or wear caused by the incompatibility of Graco equipment with structures, accessories, equipment or materials not supplied by Graco, or the improper design, manufacture, installation, operation or maintenance of structures, accessories, equipment or materials not supplied by Graco.

This warranty is conditioned upon the prepaid return of the equipment claimed to be defective to an authorized Graco distributor for verification of the claimed defect. If the claimed defect is verified, Graco will repair or replace free of charge any defective parts. The equipment will be returned to the original purchaser transportation prepaid. If inspection of the equipment does not disclose a defect in material or workmanship, repairs will be made at a reasonable charge, which charges may include the costs of parts, labor and transportation.

THIS WARRANTY IS EXCLUSIVE, AND IS IN LIEU OF ANY OTHER WARRANTIES, EXPRESS OR IMPLIED, INCLUDING BUT NOT LIMITED TO WARRANTY OF MERCHANTABILITY OR WARRANTY OF FITNESS FOR A PARTICULAR PURPOSE.

Graco's sole obligation and buyer's sole remedy for any breach of warranty shall be as set forth above. The buyer agrees that other remedy (including, but not limited to, incidental or consequential damages for lost profits, lost sales, injury to person or property, or any other incidental or consequential loss) shall be available. Any action for breach of warranty must be brought within two (2) years of the date of sale.

Graco makes no warranty, and disclaims all implied warranties of merchantability and fitness for a particular purpose in connection with accessories, equipment, materials or components sold but not manufactured by Graco. These items sold, but not manufactured by Graco (such as electric motors, switches, hose, etc.), are subject to the warranty, if any, of their manufacturer. Graco will provide purchaser with reasonable assistance in making any claim for breach of these warranties.

In no event will Graco be liable for indirect, incidental, special or consequential damages resulting from Graco supplying equipment hereunder, or the furnishing, performance, or use of any products or other goods sold hereto, whether due to a breach of contract, breach of warranty, the negligence of Graco, or otherwise.

FOR GRACO CANADA CUSTOMERS

The parties acknowledge that they have required that the present document, as well as all documents, notices and legal proceedings entered into, given or instituted pursuant hereto or relating directly or indirectly hereto, be drawn up in English. Les parties reconnaissent avoir convenu que la rédaction du présente document sera en Anglais, ainsi que tous documents, avis et procédures judiciaires exécutés, donnés ou intentés à la suite de ou en rapport, directement ou indirectement, avec les procédures concernées.

ADDITIONAL WARRANTY COVERAGE

Graco does provide extended warranty and wear warranty for products described in the "Graco Contractor Equipment Warranty Program".

All written and visual data contained in this document reflects the latest product information available at the time of publication. Graco reserves the right to make changes at any time without notice.

Sales Offices: Minneapolis, Detroit

Foreign Offices: Belgium, England, Korea, France, Germany, Hong Kong, Japan

GRACO INC. P.O. BOX 1441 MINNEAPOLIS, MN 55440-1441

<http://www.graco.com>

PRINTED IN USA 308870 March 1999, Revised May 1999