 <p><b>This manual contains important warnings and information. READ AND KEEP FOR REFERENCE.</b></p>
<b>INSTRUCTIONS</b>

*First choice when quality counts.™*

**GTS-4900 HVLP**

## **2-Speed Turbine Conversion Kit (120V)**

**Model 241123, Series A**

2-Speed Turbine Conversion Kit for 120V GTS-4900 Four-Stage HVLP Turbine Sprayer

*8 psi (55 kPa, 0.5 bar) Maximum Working Pressure*

### **Related Manual**

HVLP Turbine Sprayers . . . . . 308808

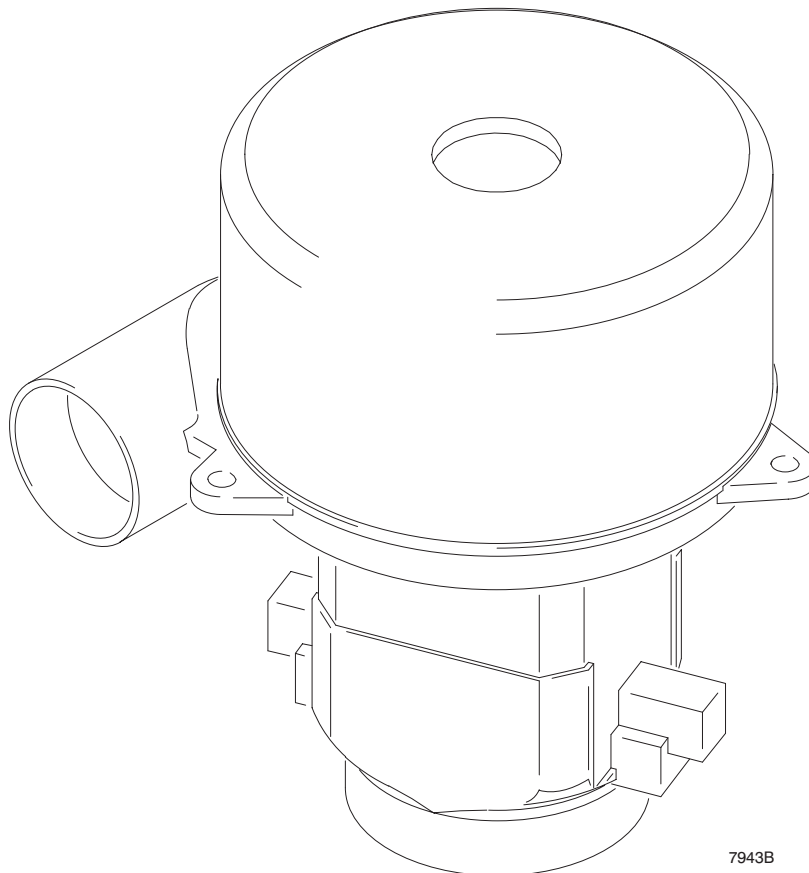

7943B

**GRACO INC. P.O. BOX 1441 MINNEAPOLIS, MN 55440-1441**

©COPYRIGHT 1999, GRACO INC.  
Graco Inc. is registered to I.S. EN ISO 9001

# Pressure Relief Procedure

## WARNING

### PRESSURIZED EQUIPMENT HAZARD

The equipment stays pressurized until pressure is manually relieved. To reduce the risk of a serious injury from pressurized fluid, accidental spray from the gun, or splashing fluid, follow the **Pressure Relief Procedure** whenever you

- Are instructed to relieve the pressure
- Stop spraying
- Check or service any of the system equipment
- Install or clean the fluid nozzles

1. Turn off air supply to gun, and turn off turbine sprayer.

## WARNING

The turbine hose outlet may be hot. Carefully check the hose end before you remove the hose.

2. If using remote pressure pot, relieve pressure by following these steps (see Fig. 1):
  - a. Turn off air supply to pressure pot.
  - b. 2<sup>1</sup>/<sub>2</sub>-gallon remote pressure pot:  
Pull pressure relief valve ring (206c) until pressure is completely relieved.  
  
2-quart remote pressure pot:  
Turn **out** pressure relief knob (113) about one turn. Wait until pressure is completely relieved before you remove cover. Close knob.

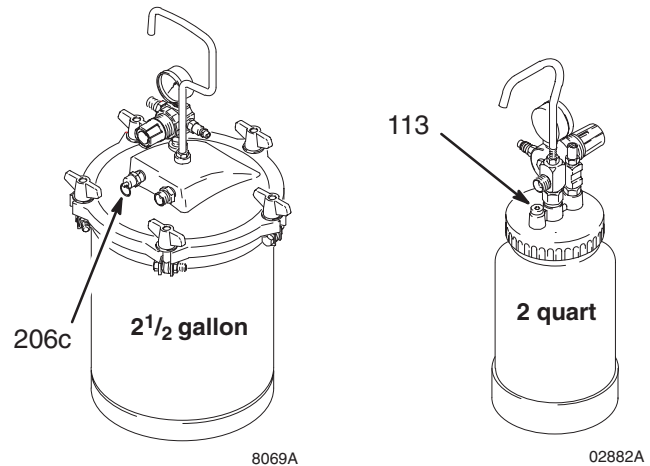

Fig. 1

3. Elevate spray gun and pull trigger to allow fluid in fluid hose to drain back into remote pressure pot.
4. If using a spray gun cup:  
Unlatch cup cover, and loosen or remove cup from cover to relieve cup pressure.
5. Clean spray gun and cup as instructed in turbine gun manual 308336 or 308810.

## Turbine Kit Installation

## WARNING

Turn off the turbine and unplug the power cord for these procedures.

Use these procedures to install the 2-Speed Turbine Conversion Kit. See Fig. 2 and Fig. 3 and the **Parts Drawing** in manual 308808.

Replace existing parts with kit parts (three-digit numbers) as required.

### Turbine Disassembly

1. If necessary, clean and replace filter according to maintenance procedure in manual 308808.
2. Place turbine upside down on work surface. Remove four cap screws (27) and bumpers (7) as shown in Fig. 2.

3. Carefully lift and remove turbine base plate (2) from cover (1). Place turbine upright on work surface.

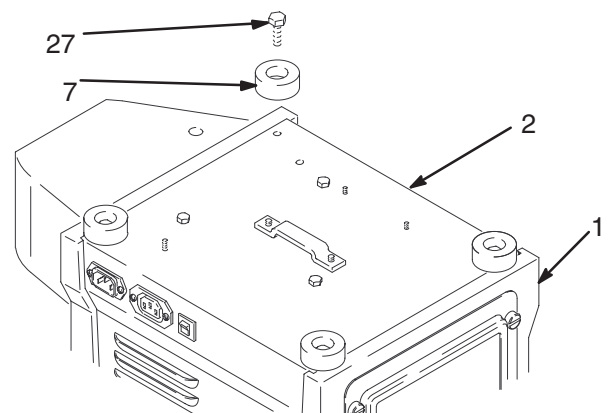

Fig. 2

7949A

# Turbine Kit Installation

One- and two-digit numbers (in parentheses) refer to parts as they are called out in manual 308808. Three-digit numbers refer to new kit parts.

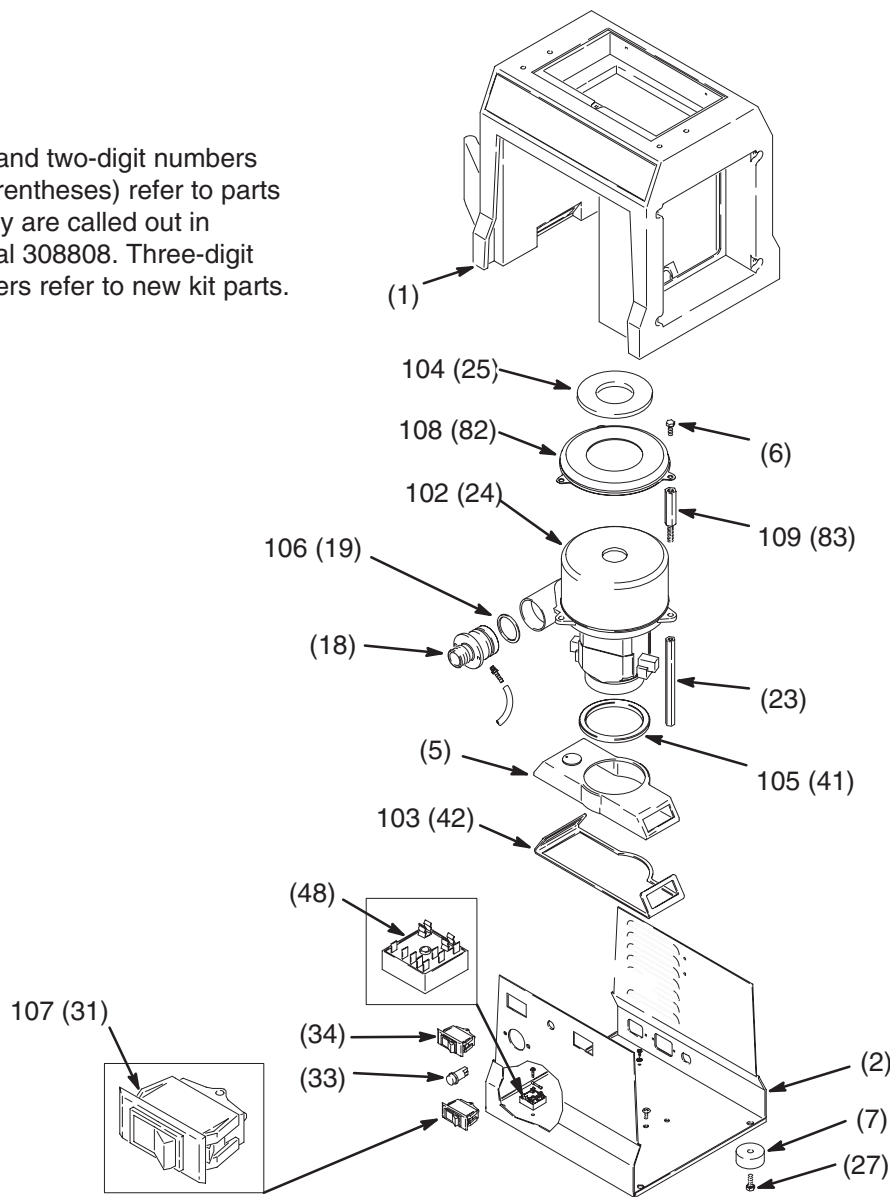

Fig. 3

7943B

- Remove turbine gasket (25), three screws (6), turbine plate (82), and three turbine spacers (83).

**NOTE:** Steps 5 and 8 apply only if your GTS-4900 turbine sprayer has a speed controller (48). Installation of this 2-Speed Turbine Conversion Kit does not include reconnecting wires to the speed controller. The speed controller is no longer used with the 2-speed turbine.

- Remove turbine motor wires from spade terminals on speed controller (48).
- Rotate turbine (24) from outlet fitting (18) and lift up from turbine spacers (23) and turbine duct (5) to remove.

- Remove rocker switch (31) and wires connected to it (Fig. 4 wiring diagram).
- Remove two remaining wires connecting speed controller (48) to red rocker switch (34) and filter indicator light (33).

## Rocker Switch Installation and Wiring

See Wiring Diagram in Fig. 4.

- In orientation shown in Fig. 3, install rocker switch (107) in hole left by removed switch (31).
- Connect male tab end of one white wire (110) to spade terminal 2 of switch (107). Position spade to outside of switch to ease connection of second wire. Connect other end of white wire to spade terminal 5 of red rocker switch (34).

# Turbine Kit Installation

3. Connect male tab end of second white wire (110) to spade terminal 1 of switch (107), and connect other end to spade terminal 6.
4. Connect male tab end of black wire (111) to spade terminal 2 on the red rocker switch (34). Connect other end to open spade terminal on filter indicator light (33).

## Installation and Wiring of 2-Speed Turbine

1. Fig. 3. Replace turbine gaskets (41 and 42) with gaskets (105 and 103) on turbine duct (5).
2. Place 2-speed turbine (102) alongside turbine base plate (2), standing it on end (large-diameter end up).
3. Connect black wire from turbine to spade terminal wire connected to terminal 2 of red rocker switch (34).
4. Connect white wire from turbine to spade terminal 5 of rocker switch (107).
5. Connect yellow wire from turbine to spade terminal wire connected to terminal 1 of rocker switch (107).
6. Connect blue wire from turbine to spade terminal 4 of rocker switch (107).
7. Connect red wire from turbine to spade terminal wire connected to terminal 2 of rocker switch (107).

## Turbine Reassembly

1. Install turbine by rotating into outlet fitting (18) using o-ring packing (106) and positioning on spacers (23) in turbine base plate.
2. Install 3 spacers (109). Reconnect ground wire ring terminal to closest spacer (109). Check that no wires are pinched by hardware.
3. Mount turbine plate (108) on spacers (109) with screws (6).
4. Install turbine gasket (104).
5. Reassemble turbine.

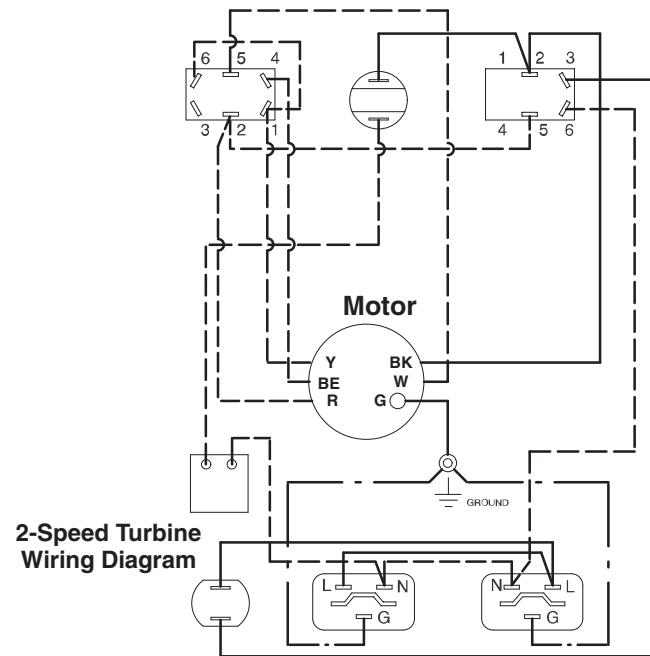

Fig. 4

7244B

## Kit Parts

Ref No.	Part No.	Description	Qty	Ref No.	Part No.	Description	Qty
102	114650	TURBINE, 4-stage, 2-speed; 120V	1	107	114658	SWITCH, rocker	1
103	192846	GASKET, duct	1	108	194094	PLATE, turbine	1
104	192788	GASKET, turbine	1	109	194097	SPACER, turbine	3
105	192845	GASKET, duct	1	110	240927	CONDUCTOR, electrical, white	2
106	156698	PACKING, o-ring	1	111	240257	CONDUCTOR, electrical, black	1

All written and visual data contained in this document reflect the latest product information available at the time of publication. Graco reserves the right to make changes at any time without notice.

Sales Offices: Minneapolis, Detroit  
Foreign Offices: Belgium, Korea, Hong Kong, Japan

GRACO INC. P.O. BOX 1441 MINNEAPOLIS, MN 55440-1441

<http://www.graco.com>

PRINTED IN USA 308924 01/1999, Revised 02/2000