

Table of Contents

Warnings	3	Fitting the Pins into the Bearings	22
System Information	5	Storage of Spare Pins and Bearings	22
Ratio Adjustment	10	Removing the Secondary Pump and/or the Bearings and Pins	22
Determining the Ratio	11	Replacing the Secondary Pump and/or the Bearings and Pins	24
Set the Ratio	12	Removing the Primary Pump and/or the Lower Bearing and Pin	25
Calculate the Ratio Setting	13	Replacing the Primary Pump and/or Bearing and Pins	27
Setting the Secondary Pump(s)	14	Replacing the Lever Arm on the Frame	28
Operation	15	Parts	30
Troubleshooting	18	Dimensions	38
Service	20	Technical Data	39
Required Service Tools	20	Graco Warranty	40
Bearing and Pump Lubrication	20	Graco Information	40
Air Lubrication	20		
Detecting Bearing and Pin Wear	20		
Removing the Lever Arm from the VRHC Frame	21		
Determining Which Pin and/or Bearing is Worn	22		

Related Manuals

Manual	No.
President® Air Motors	306982
Monark® Air Motors	307043
Bulldog® Air Motors	307049
Viscount I	307654
Displacement Pump	307430
Displacement Pumps	307431
Displacement Pumps	307944
Displacement Pumps	684004
Configurator Product Order Form	309025
Displacement Pumps	306936
Displacement Pumps	307862

Warnings

Warning Symbol



This symbol alerts you to the possibility of serious injury or death if you do not follow the instructions.

Caution Symbol



This symbol alerts you to the possibility of damage to or destruction of equipment if you do not follow the instructions.

! WARNING



INSTRUCTIONS



EQUIPMENT MISUSE HAZARD

Equipment misuse can cause the equipment to rupture, malfunction, or start unexpectedly and result in serious injury.

- This equipment is for professional use only.
- Read all instruction manuals, warnings, tags, and labels before operating the equipment.
- Use the equipment only for its intended purpose. If you are uncertain about usage, call your Graco distributor.
- Do not alter or modify this equipment. Use only genuine Graco parts and accessories.
- Check the equipment daily. Repair or replace worn or damaged parts immediately.
- See Configurator Product Order Form 309025 for important pressure rating information. The maximum working pressure of each model is also shown on the pump identification plate. Be sure that all dispensing equipment and accessories are rated to withstand the maximum working pressure of your pump. Do not exceed the maximum working pressure of the lowest rated system component.
- Never operate the pump without the automatic pressure relief valves and drainage kits installed. These valves relieve fluid pressure through a drain port at the bottom of the valve if the displacement pump pressure exceeds the working pressure.
- Never exceed the recommended working pressure or the maximum air inlet pressure stated on your pump or in the Configurator Product Order Form 309025.
- Do not lift pressurized equipment.
- Use only Graco approved hoses. Do not remove hose spring guards, which help protect the hose from rupture caused by kinks or bends near the couplings.
- Route the hoses away from the traffic areas, sharp edges, moving parts, and hot surfaces. Do not expose Graco hoses to temperatures above 180°F (82°C) or below -40°F (-40°C).
- Do not use the hoses to pull the equipment.
- Use fluids and solvents that are compatible with the equipment wetted parts. See the **Technical Data** section of all the equipment manuals. Read the fluid and solvent manufacturer's warnings.
- Comply with all applicable local, state and national fire, electrical and other safety regulations.

⚠ WARNING



SKIN INJECTION HAZARD

Spray from the spray gun, hose leaks, or ruptured components can inject fluid into your body and cause extremely serious injury, including the need for amputation. Splashing fluid in the eyes or on the skin can also cause serious injury.

- Fluid injected into the skin might look like just a cut, but it is a serious injury. **Get immediate medical surgical treatment.**
- Do not point the gun/valve at anyone or at any part of the body.
- Do not put your hand or fingers over the spray tip/nozzle.
- Do not stop or deflect fluid leaks with your hand, body, glove, or rag.
- Do not “blow back” fluid; this is not an air spray system.
- Check the gun diffuser operation weekly. Refer to the gun manual.
- Always have the trigger guard on the gun when dispensing.
- Be sure the gun/valve trigger safety operates before dispensing.
- Lock the gun/valve trigger safety when you stop dispensing.
- Follow the **Pressure Relief Procedure** on page 15 whenever you: are instructed to relieve pressure; stop spraying/dispensing; clean, check, or service the equipment; and install or clean the spray tip/nozzle.
- Tighten all fluid connections before operating the equipment.
- Check the hoses, tubes, and couplings daily. Replace worn, damaged, or loose parts immediately. Do not repair high pressure couplings; you must replace the entire hose.
- Fluid hoses must have spring guards on both ends, to help protect them from rupture caused by kinks or bends near the couplings.





FIRE, EXPLOSION AND ELECTRIC SHOCK HAZARD

Improper grounding, poor air ventilation, open flames, or sparks can cause a hazardous condition and result in fire, explosion, or electrostatic shock and other serious injury.

- Ground the equipment, the object being dispensed, and all other electrically conductive objects in the dispense area. Proper grounding dissipates static electricity generated in the equipment. Refer to **System Grounding** on page 9.
- Provide fresh air ventilation to avoid the buildup of flammable fumes from solvent or material.
- Do not use the heater with flammable liquids, such as those having flash points below 200° F (93° C).
- Extinguish all open flames or pilot lights in the dispense area.
- Do not turn on or off any light switch in the dispense area.
- Do not use this equipment with flammable liquids.
- Keep the dispense area free of debris, including solvent, rags, and gasoline.
- Do not smoke in the dispense area.
- Do not operate a gasoline engine within the spray area.
- If there is any static sparking or you feel an electric shock while using the equipment, **stop dispensing immediately**. Do not use the equipment until you have identified and corrected the problem.

WARNING

	<p>MOVING PARTS HAZARD</p> <p>Moving parts can pinch fingers.</p> <ul style="list-style-type: none">● Keep clear of all moving parts when starting or operating the equipment.
	<p>TOXIC FLUID HAZARD</p> <p>Hazardous fluid or toxic fumes can cause serious injury or death if splashed in the eyes or on the skin, inhaled, or swallowed.</p> <ul style="list-style-type: none">● Know the specific hazards of the fluid you are using.● Store hazardous fluid in an approved container. Dispose of hazardous fluid according to all local, state and national guidelines.● Always wear protective eyewear, gloves, clothing and respirator as recommended by the fluid and solvent manufacturer.● Avoid exposure to heated material fumes.● Provide adequate ventilation.● Graco does not manufacture or supply any of the reactive chemical components that may be used in this equipment and is not responsible for their effects. Graco assumes no responsibility for loss, damage, expense or claims for personal injury or property damage, direct or consequential, arising from the use of such chemical components.

System Information

This manual describes pumps designed to be part of a Variable Ratio Hydra-Cat Pump (VRHC) dispensing system. The VRHC proportions, mixes, and dispenses two component fluid materials by powering two positive displacement pump lowers from a common air motor. This assures that the stroke rate and stroke length of all pump lowers are proportional as set, providing constant proportioning. The mix ratio is determined by the movement of the outboard (slave) pump along the arm of the machine. This movement changes the stroke of the slave cylinder and, along with its volumetric output relationship to the master cylinder, determines the output (volumetric) ratio. The volumetric ratio is expressed as the proportion of the volume of fluid of the primary pump compared to the volume of the secondary pump.

The basic proportioner includes an air motor, lower displacement pumps, air controls, fluid inlet hardware, fluid outlet hoses, manifold blocks and relief valve. Additional proportioner accessories are selectable to complete the proportioner pump (see Configurator Product Order Form 309025).

Typical Installation

About Typical Installations

The typical installations shown below and on page 7 are only guidelines to setting up a complete VRHC system. For clarity, various components are shown in the correct order but may not be shown in the exact position of the installed system. For assistance in designing your system, contact your nearest Graco representative.

NOTE: When pressure feeding the proportioning pump, mount fluid pressure gauges (J) at the proportioning pump inlets to monitor proper adjustment of the feed pump pressures. **Never exceed 400 psi on the inbound fluid pressure and never exceed 25% of the Hydra-Cat pump outbound fluid pressure on the feed supply.**

Airless Spray Dispensing System for Light Viscosity Fluids

KEY	P Static Mixer	13 Air Regulator
E Air Supply	R Primary Pump Inlet	45 Bleed-type Master Air Valve
F Base Supply	T Secondary Pump Inlet	46 Pressure Relief Valve
G Catalyst Supply	U Solvent Pump	104 Pressure Gauge
H Base Supply Pump	V Airless Spray Gun	120 Mixer Manifold
J Air Shutoff Valve	X Grounded Fluid Hose	123 Air Motor
K Catalyst Supply Pump	8 Air Pressure Gauge	124 Secondary Proportioning Pump (Slave)
L Air Line Filter		

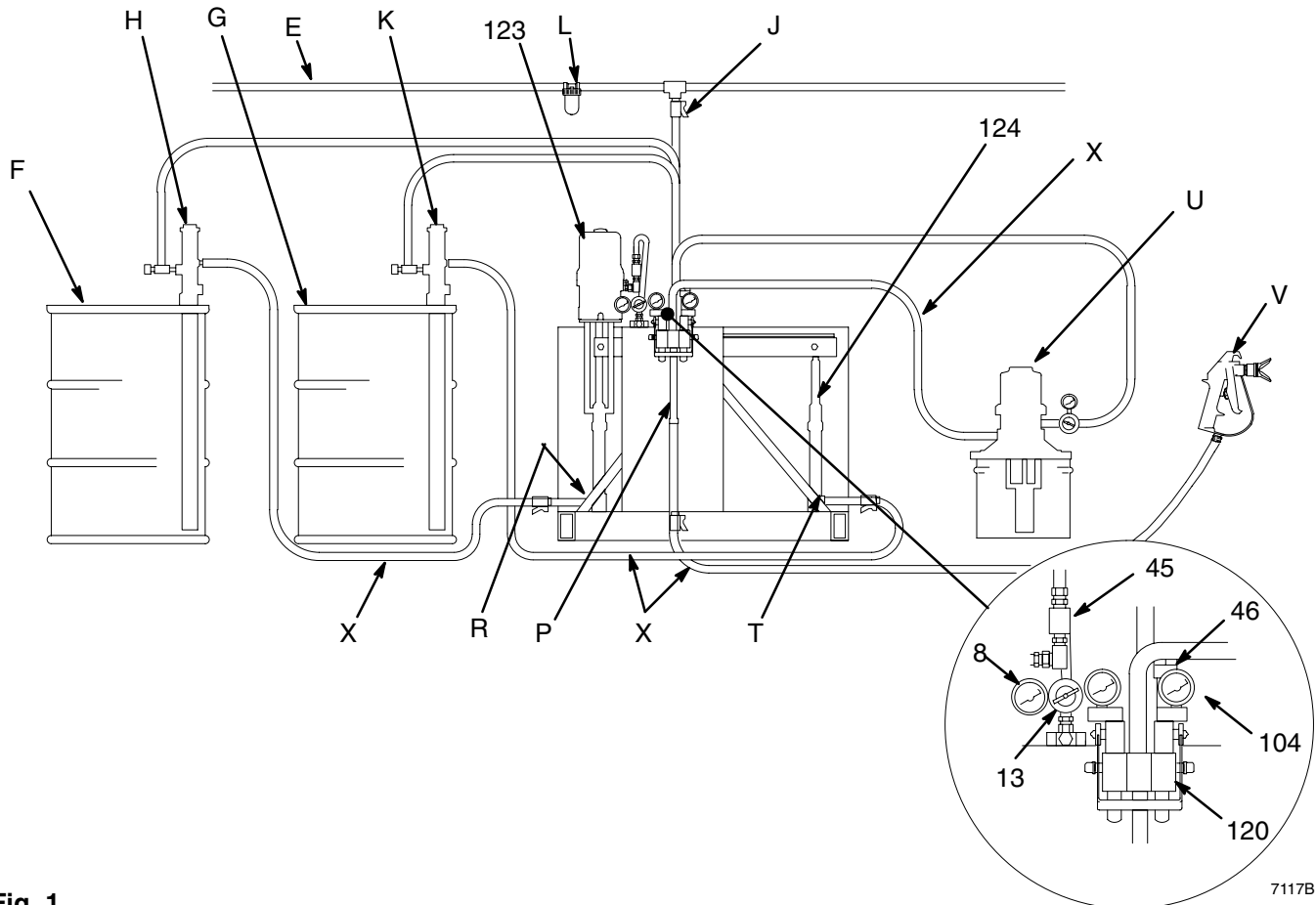

Fig. 1

7117B

KEY

- A** Hydraulic Pump
- B** Mounting Stand
- C** Hydraulic Supply Line
- D** Hydraulic Return Line
- E** Drain Line (from pressure reducing valve)
- F** Pressure Gauge
- G** Flow Control Valve
- H** Pressure Reducing Valve
- J** Accumulator

- K** Feed Pumps
- P** Hydraulic Supply Line Shutoff Valve
- R** Hydraulic Return Line Shutoff Valve
- S** Hydraulic Return Line Filter
- U** Hydraulic Power Supply
- V** Fluid Hose
- W** Fluid Supply Line
- Y** Pump Ground Wire (required)

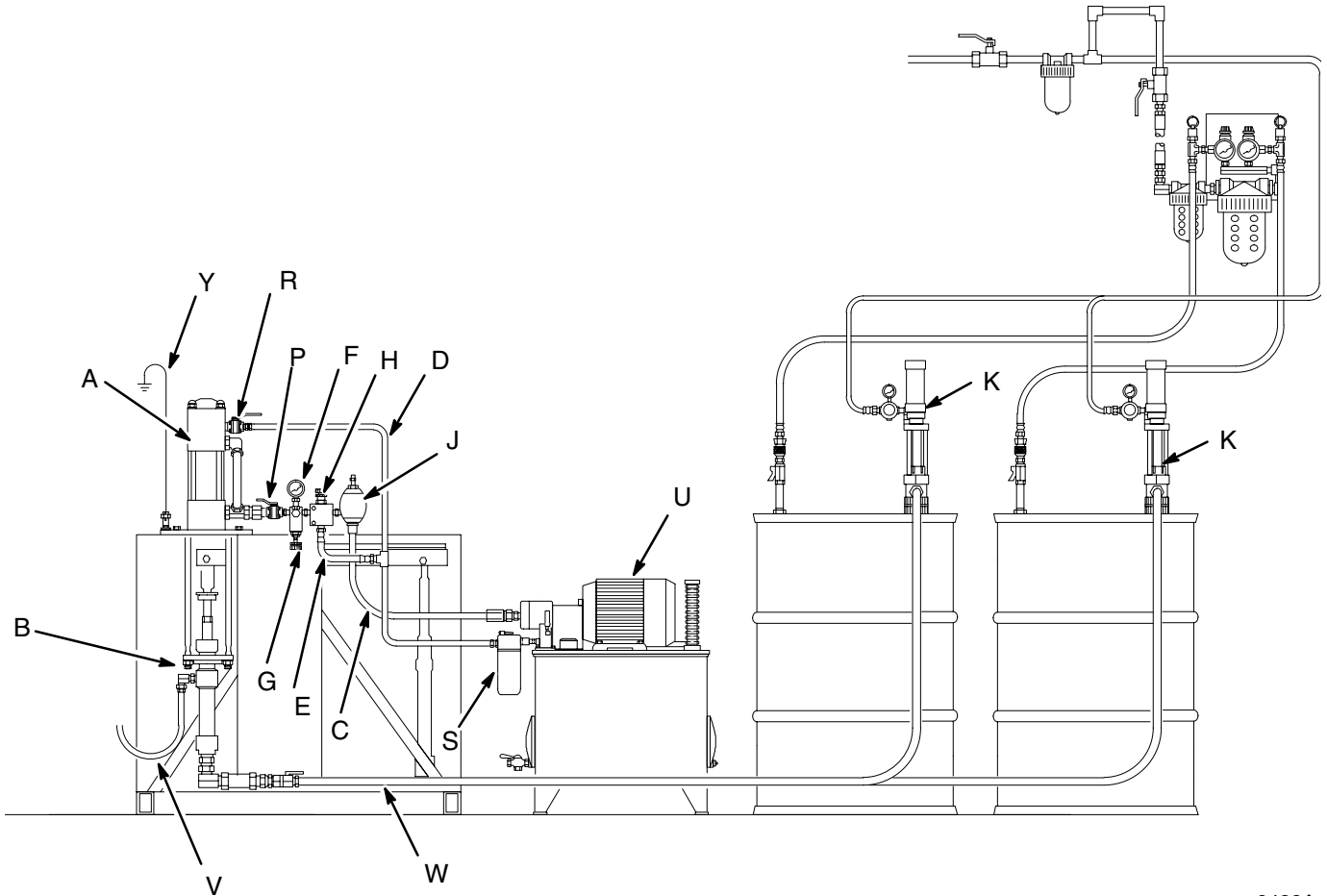

9433A

Fig. 2

Installation

NOTE: Reference numbers and letters in the text refer to Figures 1 to 18.

Location

Sit the proportioner on a flat floor positioner.

Connect the Solvent Flush Supply Line

Remove the safety panels (38,39,40). See Fig. 4 on page 10. Connect a grounded fluid hose (X) from the solvent flush pump to the 3/8 npt solvent flush inlet (N) of the mixer manifold.

Connect the Fluid Supply Lines

Connect grounded fluid hoses to the 3/4 npt(f) inlet filter fittings (R,T). If the unit will be pressure fed from separate supply pumps, install a fluid pressure gauge at each inlet.

NOTE: Pressurized fluid supplies must not exceed 1/4 the operating fluid pressure of the pump or 400 psi, whichever is less. Pressure above that level will feed through the pump and improper proportioning will result.

Connect the Static Mixer to the Manifold

Connect the static mixer (P) to a grounded fluid hose and spray gun or dispensing valve to the end of the static mixer. If multiple guns are used, connect a manifold or pipe "T" to the bottom of the static mix tube and connect ball valves at each outlet. Connect an applicator fluid hose to each ball valve.

IMPORTANT: Each side must be flushed at each application to ensure the lines do not plug with cured material.

Tighten all fittings. Replace the safety panels (38,39,40).

System Accessories

Refer to Figures 1 and 2 and **Accessories** in Configurator Product Order Form 309025.

NOTE: To ensure maximum pump performance, be sure all accessories are properly sized to meet your system requirements.

In the air line, install an air filter (L) to remove harmful dirt and moisture from the compressed air supply. Downstream from the air filter, the air regulator (13) and the bleed-type master air valve (45), install an air line lubricator to provide automatic lubrication to the motor.

WARNING

The bleed-type master air valve (45) is required in your system to relieve air trapped between this valve and the pump after the pump is shut off. Trapped air can cause the pump to cycle unexpectedly, resulting in serious injury, including amputation.

Connect the Air Supply Line

Connect a grounded air supply hose to the 1/2 npt(f) port of the air manifold (37). Open the bleed-type master air valve (45), and using the pressure gauge (8), set the air regulator (13) to the desired pressure. See Figure 1 and 2.

Pressure Relief Valve

Before operating the VRHC, make sure all components have rated working pressures of 3000 psi (21 MPa, 207 bar) or greater. For more information about the pressure relief valve, see Instruction Manual 308547.

Installation

Grounding

⚠ WARNING

FIRE AND EXPLOSION HAZARD
Before operating the pump, ground the system as explained below. Also read the section **FIRE AND EXPLOSION HAZARD** on page 4.



1. *Pump*: use the ground wire and clamp (supplied). See Fig. 3. Loosen the grounding lug locknut (W) and washer (X). Insert one end of the ground wire (Y) into the slot in lug (Z) and tighten the locknut securely. Connect the other end of the wire to a true earth ground.

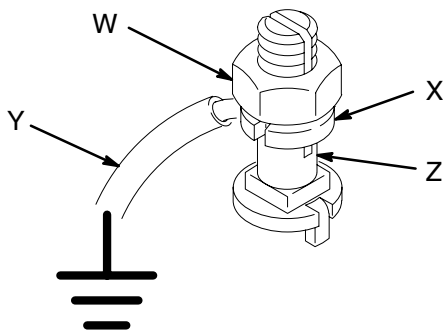

Fig. 3

0864

2. *Air and fluid hoses*: use only electrically conductive hoses.
3. *Air compressor*: follow manufacturer's recommendations.
4. *Spray gun/dispense valve*: ground through connection to a properly grounded fluid hose and pump.
5. *Fluid supply container*: follow your local code.
6. *Object being sprayed*: follow your local code.
7. *Solvent pails used when flushing*: follow your local code. Use only metal pails, which are conductive, placed on a grounded surface. Do not place the pail on a nonconductive surface, such as paper or cardboard, which interrupts the grounding continuity.
8. *To maintain grounding continuity when flushing or relieving pressure*, hold a metal part of the spray gun/dispense valve firmly to the side of a grounded metal pail, then trigger the gun/valve.

Ratio Adjustment

Understanding the terms used with the **Variable Ratio Hydra-Cat® (VRHC) System**, how it functions, and how to find and set the correct ratio(s) for your application, is the key to easier, more versatile operation of your proportioning system.

Be sure to read and understand the following information before operating the equipment.

Terms

The **ratio** refers to the simultaneous output of a certain volume of fluid by the primary and secondary pumps.

The **primary pump** (123) is directly under the motor; it usually pumps the base fluid.

The **secondary pump** (124) is on the opposite end of the lever arm (49). It usually pumps the catalyst. One or two secondary pumps may be used: one for pumping catalyst and the other for reducer injection. If two secondary pumps are used, then two ratios exist.

The **ratio index clamp** (30) is used to adjust the ratio of the secondary pump(s).

There are three main points to remember when applying the use of ratios:

1. Determine the ratio required.
2. Calculate the ratio setting.
3. Set the ratio on the VRHC System.

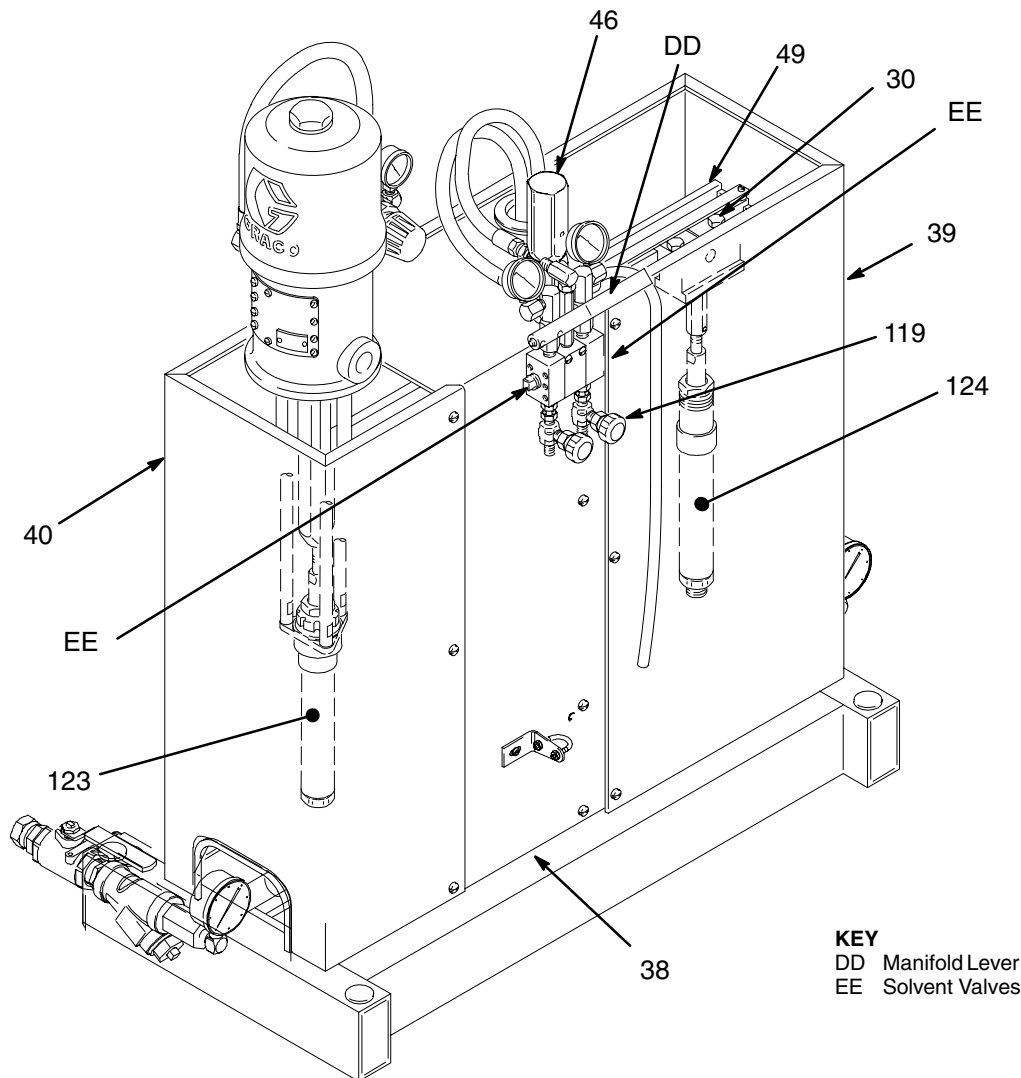

02366B

Fig. 4

Determining the Ratio

Determine your system conditions

If these are your conditions – one primary pump, one secondary pump, fluids are ready-to-spray viscosity – set the ratio as explained under **Setting the Secondary Pump(s)** on page 14.

If these are your conditions – one primary pump and one secondary pump, fluids are NOT ready-to-spray viscosity – the ratio must be determined after the reducer is added to the base, as instructed in **Procedure 1**.

NOTE: The addition of the reducer in the base causes changes to the ratio. To prevent reducer evaporation, store the base in closed containers.

NOTE: Some reducers have very little ability to lubricate and may cause seals to dry out. To prolong seal life, be sure your pump seals are compatible with the base's reducer. Contact your Graco distributor for the correct seals to use.

Procedure 1: Base Is Pre-reduced

When adding reducer to the base before proportioning with the VRHC System, determine the ratio of the base/reducer mixture to the catalyst in order to set the secondary pump at the correct position.

In this example, the instructions on the can say, "Mix 5 parts base to 1 part catalyst. Then reduce 3 parts of this mixture to 1 part reducer."

1. Add the parts of the base and catalyst to find the parts mixture.

$$\begin{array}{r} 5 \text{ parts base} \\ + \underline{1} \text{ parts catalyst} \\ 6 \text{ parts mixture} \end{array}$$

2. The next statement on the can says, "Reduce 3 parts of the mixture." So divide the parts of the mixture by 3 to find the parts reducer.

$$\begin{array}{r} 6 \text{ parts mixture} \\ \div \underline{3} \text{ part catalyst} \\ 2 \text{ parts reducer} \end{array}$$

3. To determine the ratio of the secondary pump, add the appropriate parts of base and reducer to find the parts combined base/reducer.

$$\begin{array}{r} 5 \text{ parts base} \\ + \underline{2} \text{ parts reducer} \\ 7 \text{ parts combined base/reducer to} \\ 1 \text{ part catalyst:} \end{array}$$

Result: The ratio of the secondary pump is 7:1.

Set the Ratio

Fig. 5 shows the relationship between the primary pump and the secondary pump.

To set the secondary pump on a standard VRHC System with only two pumps, refer to **Setting the Secondary Pump(s)** on page 14.

To set the secondary pump on a non-standard VRHC System or for an additional secondary pump, refer to **Calculate the Ratio Setting**, on page 13.

NOTE: The (91) **index setting** provides equal primary and secondary pump stroke lengths. 100 is 1.1 times the primary pump stroke, allowing adjustability on both sides of the nominal ratio setting of 91. If the same primary and secondary pump models are used, a 91 setting will give a 1:1 ratio. If different pump models are used, you must know the pump's effective area to determine the setting. The displacement pumps effective areas are listed in Configurator Product Order Form 309025

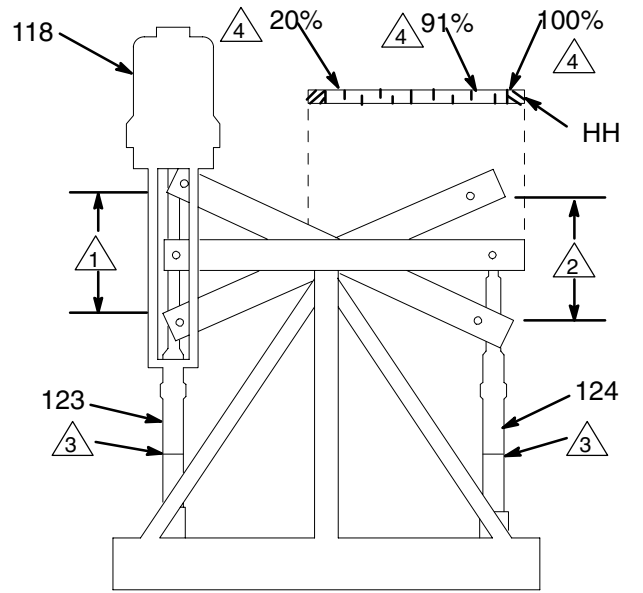

KEY
HH Lever Arm Index

- 02368
- 1 Primary Stroke – 4" (102 mm)
 - 2 Secondary Stroke
 - 3 Effective Area
 - 4 Index Setting

Fig. 5

Relationship Between Primary and Secondary Pump

Moving the secondary pump closer to the primary pump (to a lower index setting) reduces the secondary stroke length, reducing its fluid output. Moving the secondary pump further from the priming pump (to a higher index setting) increases the secondary stroke length, which increases its fluid output.

Calculate the Ratio Setting

In this example,

- A 5:1 ratio of base to catalyst is required.
- The base/primary pump Model (e.g. 221074); effective area is 0.470 in.²
- The catalyst/secondary pump Model (e.g. 221026); effective area is 0.278 in.²

1. To determine the base to catalyst setting.

- a. Multiply the primary pump's effective area by 91 (nominal ratio setting).

$$\begin{array}{r} 0.47 \text{ primary pump's effective area} \\ \times \underline{91} \text{ nominal ratio setting} \\ \hline 42.77 \text{ answer a} \end{array}$$

- b. Multiply the catalyst pump's effective area by the ratio required.

$$\begin{array}{r} 0.278 \text{ catalyst pump's effective area} \\ \times \underline{5} \text{ ratio required} \\ \hline 1.39 \text{ answer b} \end{array}$$

- a. Divide answer a by answer b to determine the index setting.

$$\begin{array}{r} 42.77 \text{ answer a} \\ \div \underline{1.39} \text{ answer b} \\ \hline 30.8 \text{ catalyst pump index setting} \end{array}$$

2. To make sure the index setting does not exceed the secondary pump's maximum stroke length:

- a. Multiply the index setting by 0.044 (a constant number).

$$\begin{array}{r} 30.8 \text{ catalyst pump setting} \\ \times \underline{0.044} \text{ constant} \\ \hline 1.355 \text{ catalyst pump stroke length} \end{array}$$

- a. See the **Pump Specifications Chart** on page 12 for the pumps' maximum stroke length. Do not use an index setting which will exceed the maximum stroke length for your pump model.

3. To make sure the index setting does not go below the secondary pump minimum ratio setting, refer to 309025 Configured Product Order Form. Do not use a ratio higher than that specified in the maximum set position, mix ratio column for your system.

4. The number (**1.355** from step 2.a.) does not exceed the pump maximum stroke nor does it go below the minimum ratio setting, so set the catalyst pump at the 30.8 index setting.

NOTE: The ratio index is only a reference point and ratio checks must be performed to qualify the exact ratio set desired..

Setting the Secondary Pump(s)

The numbers of the pump settings, calculated from the procedures in the section, **Calculate the Ratio Setting**, correspond to the scale numbers on the lever arm (49) of the VRHC. See Fig. 6.

WARNING

To reduce the risk of serious injury whenever you are instructed to relieve pressure, always follow the **Pressure Relief Procedure** on page 15.

1. Relieve the pressure.
2. Flush the unit as instructed on page 16 before setting the pump.
3. Remove the safety panel (39). See Fig. 8 on page 17.
4. Loosen the four capscrews (16) holding the secondary pump(s) in place.
5. Open the fluid outlet and lift or push the lever arm (49) to the horizontal position.
6. Move the secondary pump so that the line on the index clamp (30) is at the desired setting on the scale (26).
7. With the secondary pump as vertical as possible, tighten the four screws (16) to 50 ft-lb (78 N.m).
8. Replace the safety panel (39).

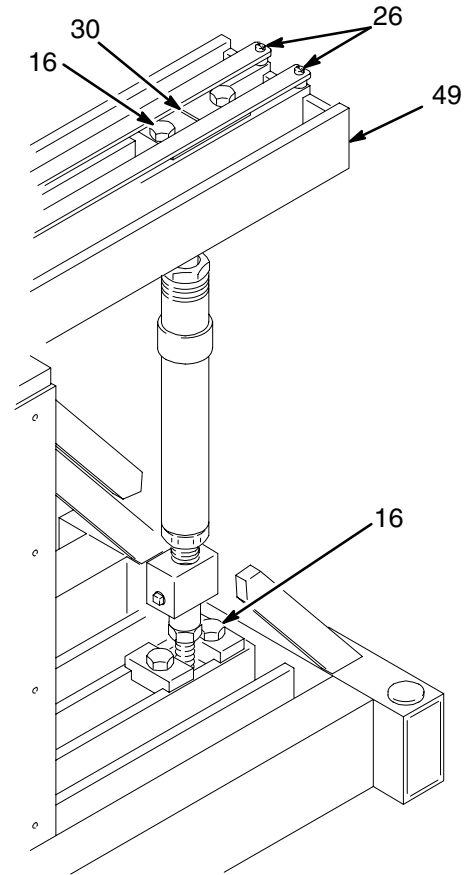

Fig. 6

02369

Operation

Pressure Relief Procedure

WARNING



SKIN INJECTION HAZARD

The system pressure must be manually relieved to prevent the system from starting or spraying/dispensing accidentally. Fluid under high pressure can be injected through the skin and cause serious injury. To reduce the risk of an injury from injection, splashing fluid, or moving parts, follow the **Pressure Relief Procedure** whenever you:

- are instructed to relieve the pressure,
- stop spraying/dispensing,
- check or service any of the system equipment,
- or install or clean the spray tip/nozzle.

1. Lock the gun/valve trigger safety.

2. Close the bleed-type master air valve (required in your system).
3. Unlock the gun/valve trigger safety.
4. Hold a metal part of the gun/valve firmly to the side of a grounded metal pail, and trigger the gun/valve to relieve pressure.
5. Lock the gun/valve trigger safety.
6. Open the drain valve (required in your system), having a container ready to catch the drainage.
7. Leave the drain valve open until you are ready to spray/dispense again.

*If you suspect that the spray tip/nozzle or hose is completely clogged, or that pressure has not been fully relieved after following the steps above, **very slowly** loosen the tip guard retaining nut or hose end coupling and relieve pressure gradually, then loosen completely. Now clear the tip/nozzle or hose.*

Operation

The pumps, mixer manifold and other components were tested with lightweight oil at the factory. Before operating the pump, thoroughly flush the VRHC to prevent contamination of the fluids.

System Flushing

NOTE: Flush the mixer, hose and gun/valve often enough to prevent fluid from reacting or curing in them. Contact your fluid manufacturer for the effective pot life of the fluid you are using.

1. Put the pump intake hoses of the feed pumps into 5 gallon (20 liter) containers of compatible solvent. Refer to the fluid manufacturer's recommendations.
2. Start the pump as explained below.
3. Do not install the spray tip/nozzle yet. Hold a metal part of the gun/valve firmly to the side of a grounded metal pail. Using the lowest possible fluid pressure, trigger the gun/valve into the pail.
4. When clean solvent comes from the gun/valve, release the trigger and carefully check all connections in the system for leaks.
5. Take the hoses out of the solvent and trigger the gun/valve until all solvent has been pumped out of the hoses.

Starting the Pump

NOTE: To open the mixer manifold (120), put the handle in the down position. To close the mixer manifold, put the handle in the up position. See Fig. 7.

CAUTION

Never exceed 25% of the normal proportioner output pressure with the feed system.

1. Start feed pump supplies and ensure fluid pressure is at least 25 psi at each pump outlet.
2. Close the bleed-type master air valve. Turn the air regulator knob all the way out (counterclockwise).
3. Turn on the main air supply.
4. Open the mixer manifold handle, trigger the gun/valve, slowly open the bleed-type master air valve, and turn the air regulator knob clockwise until the pump starts.
5. Allow the pump to cycle slowly until all the air is pushed out of the lines. Release the trigger – the pump will stall against the pressure.
6. The manifold handle controls fluid flow. When the manifold is open, base and catalyst are supplied to the gun/valve. To stop the flow, close the handle.

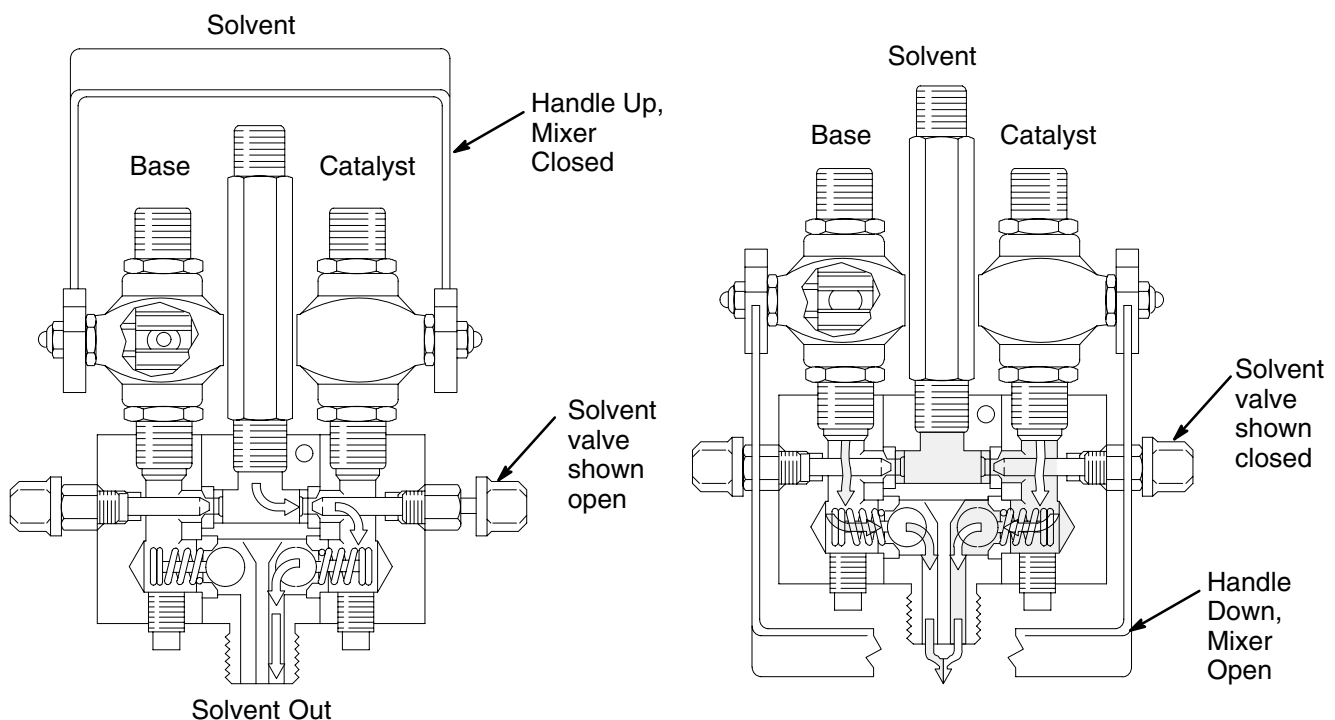

Fig. 7

02370

Operation

NOTE: To open the mixer manifold (120), put the handle in the down position. To close the mixer manifold, put the handle in the up position. See Fig. 7 on page 16.

Standard Operating Flushing

1. Use the solvent valves to flush contaminants and mixed fluids from the mixer manifold, hose and gun/valve. Follow the procedure below.
 - a. Start the solvent pump. Close the mixer manifold.
 - b. Open one of the solvent valves (EE).
 - c. Trigger the gun/valve into the metal pail until the solvent valve is thoroughly flushed. Release the trigger.
 - d. Close the open solvent valve. Open the other solvent valve. Repeat step c
 - e. With both solvent valves open, flush until all contaminants and fluids are removed. Release the trigger.
2. To flush the sampling valves (119), place a grounded metal pail under them. Turn the valve handle to the open position. Flush until all contaminants and fluids are removed. Close the sampling valves and solvent valves. The solvent valves should be finger tight only, but must be tight enough to prevent solvent from mixing with the fluid during operation.
3. Trigger the gun/valve to relieve pressure.

Checking the Ratio

1. Open the mixer manifold (120).
2. Set the operating pressure. After determining the operating pressure, release the gun/valve trigger and lock the trigger safety.
3. Close the mixer manifold.
4. Open the sample valve (119) on the secondary pump side approximately three turns. Open the sampling valve on the primary pump side just one turn. This prevents the pressure from building up on the secondary pump, which would cause the relief valve (46) to open.

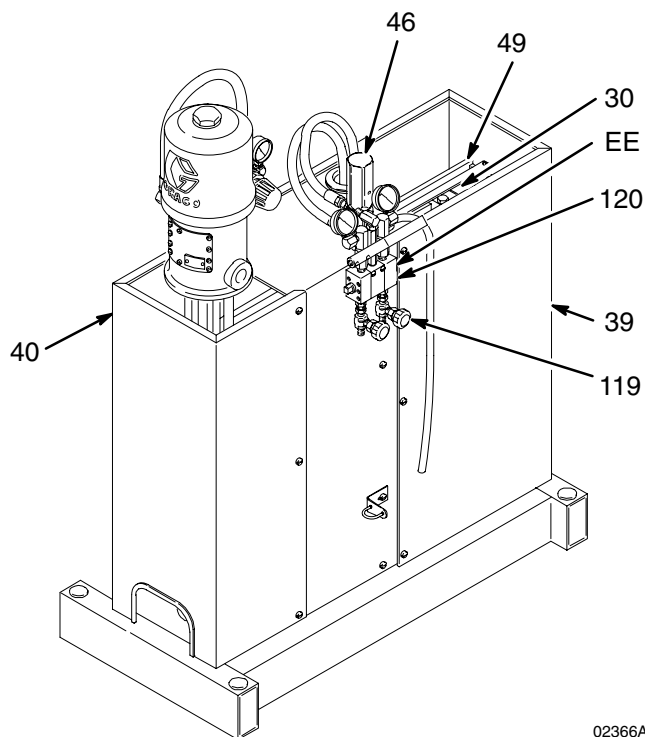

Fig. 8

02366A

5. Place a grounded metal pail under the sampling valves.
6. Open the mixer manifold. Use the sampling valves to adjust the pressures to your normal operating pressure.
7. Close the mixer manifold. Put the sampling containers under the sampling valves.
8. Open the mixer manifold. Check the ratio. Make sure the pressure is within 20% of the normal operating pressure. Close the mixer manifold when enough fluid has been dispensed into the sampling containers.

NOTE: If the pressure is not within 20% of the normal operating pressure, follow the flushing procedure on page 16, and then take another sample. If the sample ratio is incorrect, there is a problem with the sample valves, secondary pump setting or the pump operation. Check the pump setting or service the sampling valves or pump.

Troubleshooting

Troubleshooting Techniques

Because the pumps are mechanically linked, the action of one pump can affect the readings of the second pump. Therefore, the key to successful troubleshooting is to be sure to isolate the problem.

For example, the secondary pump pressure, as read on the gauge, is low and sluggish during pump changeover. The most likely problem is a binding primary pump.

WARNING

To reduce the risk of serious injury whenever you are instructed to relieve pressure, always follow the **Pressure Relief Procedure** on page 15.

To isolate the pump:

1. Relieve the pressure.
2. Disconnect the index clamp (30) from the secondary pump and lean the pump out of the way of the lever arm (49). Now you can verify the operation of the primary pump alone.
3. Use the sampling valves (119) at the mixer manifold (120).
 - a. Check the outlet ratio for the primary side.
 - b. With the sampling valves closed, check for pump stalling on both the up and down strokes.
 - c. Check for rapid gauge response during pump changeover.
4. When the operation of the primary side has been verified, reconnect the lever arm (49) to the secondary pump. Let the primary pump run freely in a pail of fluid and repeat the checks in Step 3 on the secondary side.

WARNING

Use very low air pressure to the air motor when making these checks. This system can produce very high fluid pressure, which can cause serious injury, including injection, splashing in the eyes or on the skin, and injury from moving parts. Follow the **Pressure Relief Procedure** on page 15.

WARNING

To reduce the risk of injuring or amputating a hand, fingers or other body parts, never place your hands or any part of your body or any tools inside the safety panel at any time, for any reason, while the unit is operating.

Refer to the manuals listed below to repair the VRHC components.

Component	Ref. No.	Manual No.
President Motor	207352	306982
Bulldog Motor	20835	307049
Monark Motor	205997	307043
Viscount I Hydraulic Motor	948699	307654
Pump Lower	215932	307430
Pump Lower	215930	307431
Pump Lower	217339	307430
Pump Lower	222012	307944
Pump Lower	239388	307944
Pump Lower	222015	307944
Pump Lower	222017	307944
Pump Lower	222019	307944
Pump Lower	217529	306936
Pump Lower	901878	307862
Pump Lower	948640	684004
Pump Lower	948641	684004
Pump Lower	948195	307944
Pump Lower	948197	307944

Troubleshooting

Problem	Cause	Solution
System won't run or stops while running	Air pressure or volume too low	Increase, check air compressor.
	Closed or restricted air line or air valve	Open or clean as required.
	Fluid valves closed	Open fluid valves.
	Clogged fluid hose	Replace fluid hose.
	Air motor worn or damaged	Service air motor; see manual 306982.
	Displacement pump stuck	Service displacement pump. See manuals listed in the chart on page 18.
Fluids not mixing properly	Clogged filter in fluid line	Clean; replace element if necessary.
	Manifold problems	Refer to manual 307400.
	Check ratio	Check; replace pump.
	Clogged fluid hose	Replace fluid hose.
System speeds up or runs erratically	Fluid containers are empty	Check often – keep filled.
	Displacement pump parts worn or damaged	Service displacement pump. See manuals listed in the chart below.
Squeaking or knocking noise is heard	Bearing(s) dry or worn	Lubricate; replace bearing(s) if necessary.
	Pump bottoming out	See below.
System stops running on the end of a stroke	Secondary displacement pump bottomed out because ratio index clamp was set too far out	Adjust ratio index clamp.
	Secondary displacement pump bottomed out because top pivot bearings are set too high	Adjust bearings. See Removing the Lever Arm from the VRHC Frame on page 21.

Service

Required Service Tools

Tool	Use for
3/32"–90° or T-handle hex key	All setscrews
3/4" open end wrench	Clamp bolts and fluid hose on pump outlet
1" open end wrench	Locknuts on capscrews
9/16" open end wrench	Tie rod nuts
1/2" open end wrench	Loosening tie rods from motor base
1–1/8" open end wrench	Pivot bearing locknuts
Adjustable open end wrench	Tightening connecting rod to pumps
Needle nose pliers	Bending and pulling cotter pins
Medium slotted screwdriver	Removing shields
Small hammer and 6" punch	Tapping out pins

Bearing and Pump Lubrication

WARNING

To reduce the risk of serious injury whenever you are instructed to relieve pressure, always follow the **Pressure Relief Procedure** on page 15.

1. Relieve the pressure.
2. Insert one end of the nylon hose (52) into the wet-cup.
3. Pour Throat Seal Liquid (44) into the hose until the wet-cup is full.
4. Lubricate the VRHC periodically with Graco Gear Reducer Oil (43). If the pump is operating continuously at 60 cycles/min., lubricate at the points shown in Fig. 9 once every five days.

Service instructions are in the manuals for the separate components. See the chart on page 18.

Air Lubrication (Air Operated Motors Only)

If your air supply is very dry, install air line lubricators between the air regulators and pumps for automatic air motor lubrication. See **Accessories** in Configurator Product Order Form 309025 for a lubricator.

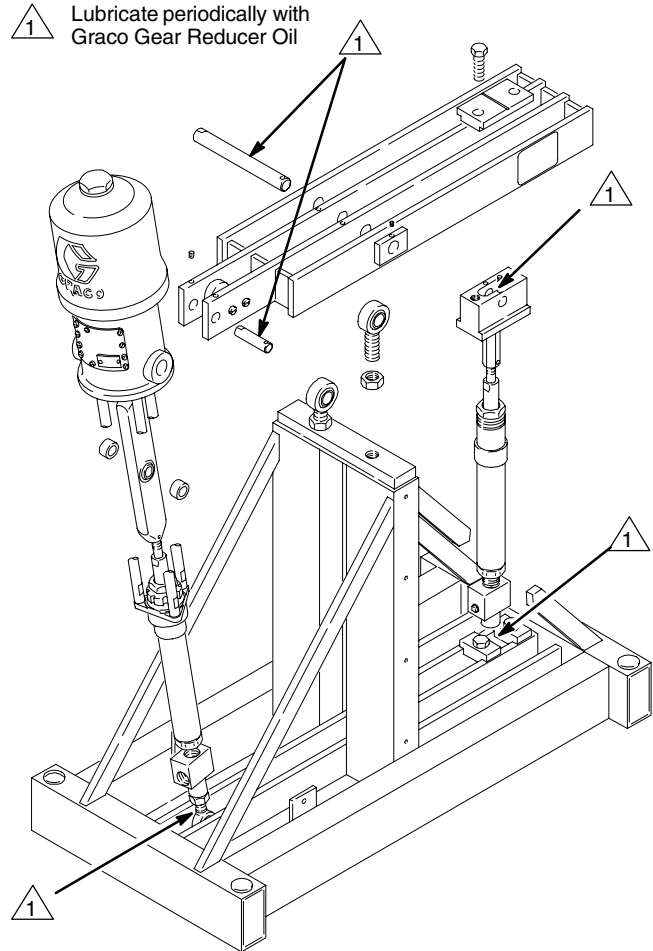

Fig. 9

02371A

Detecting Bearing and Pin Wear

Audio Detection

When a bearing fails, it makes a knocking noise each time the pump changes stroke. Shut off the system immediately to avoid serious damage. Replace the bearing(s).

Visual Detection

Check the movement of the lever arm (49) by watching it through the opening in the safety panel (39). If it bounces, shut off the system immediately to avoid serious damage. Replace the bearing pin.

Service

Removing the Lever Arm from the VRHC Frame

⚠ WARNING

To reduce the risk of serious injury whenever you are instructed to relieve pressure, always follow the **Pressure Relief Procedure** on page 15.

1. Flush the entire system with a solvent which is compatible with the fluid being pumped. Disconnect the air line and relieve the pressure.
2. Remove the safety panels (38,39,40). See Fig. 10.
3. Loosen the two setscrews (59) holding the primary displacement pump pin (35c) in the lever arm (49). See Fig. 11. The setscrews must be backed out far enough to clear the countersinks of the pin. Tap the pump pin out of the lever arm and bearing.
4. Slide the primary pump out of the lever arm (49) slot and save the two nylon spacers (27c).
5. Slowly lower the pump to the floor until it supports itself with the lower bearing (14d). See Fig. 17 on page 27.
6. Push down on the secondary displacement pump end of the lever arm (49) at point (JJ) until it is at the bottom of the stroke. See Fig. 11.
7. Remove the two top capscrews (16a) from the index clamp (30).
8. Raise the lever arm (49) slowly. Lower the secondary pump to the floor until it supports itself with the lower bearing.
9. Loosen the two setscrews (17) located above the ends of the frame pin (33). The setscrews must be turned out far enough to clear the countersinks of the pin.
10. Using a long punch and hammer, gently drive the frame pin (33) out from one end until it can be pulled out.

⚠ CAUTION

Do not drop the pin; dents will make reassembly difficult.

11. Remove the punch and lift the lever arm (49) off the VRHC frame.
12. Loosen the two pivot bearing locknuts (2) and turn the bearings (15) out of the housing (122). The bearings should be only hand tight. If they are tighter, use a wrench on the flats of the bearing (15) to unscrew the bearing from the frame.

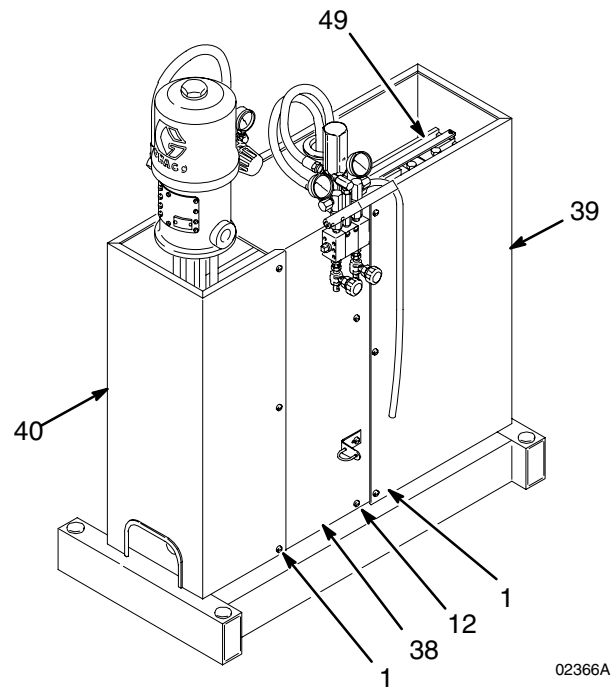

Fig. 10

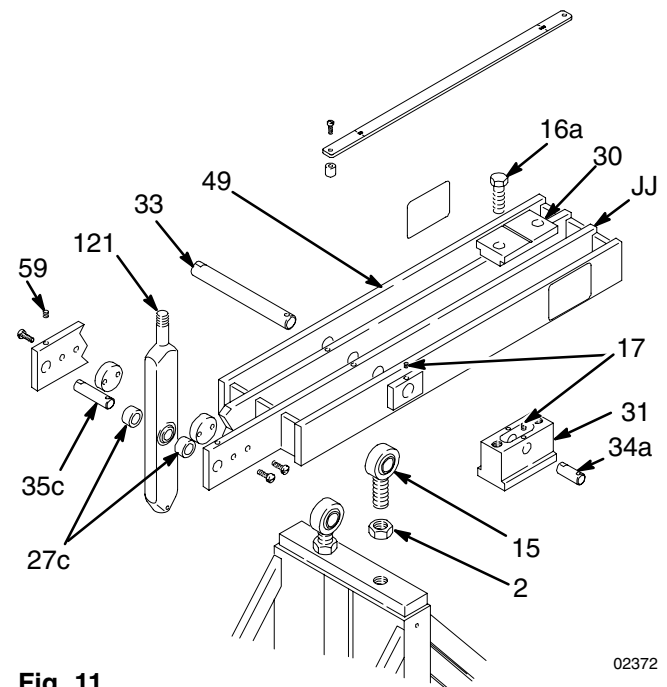

Fig. 11

Service

Determining Which Pin and/or Bearing is Worn

1. Disassemble the VRHC. After the pins and bearings are removed, wipe them off with a clean rag.
2. Visually inspect the pins for scoring, lines, grooves and scratches on the area in contact with the bearing. Then feel the surface of the pin for rough areas or a difference in size. If these signs of wear are detected, replace both the pin and bearing.
3. To check the bearings, hold the threaded part of the bearing in one hand and use the other hand to move the balls inside the bearing up and down. If there is any noticeable movement, replace the bearings. Also check the bearings for roundness. If a bearing appears to be out of round (egg-shaped), replace it.

Fitting the Pins into the Bearings

Tolerances between the surface of the pin and the bearings are very close. Never force the pin into the bearing. If the pin does not fit, sand it from the end to just past the countersinks with 500 grit sandpaper. See Fig. 12. If the pin still does not fit, return it to the factory for replacement. If the pin needs replacement, replace the bearing also.

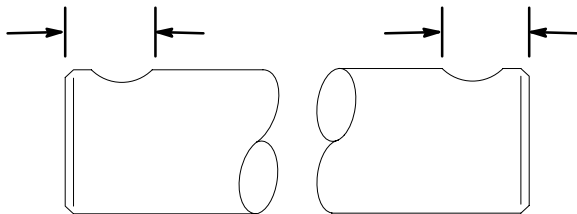

Fig. 12

02373

Storage of Spare Pins and Bearings

Completely coat spare pins and bearings with Graco Gear Reducer Oil (43) or the equivalent when storing these parts. Never use grease.

Removing the Secondary Pump and/or the Bearings and Pins

1. Flush the entire system with a compatible solvent.

WARNING

To reduce the risk of serious injury whenever you are instructed to relieve pressure, always follow the **Pressure Relief Procedure** on page 15.

2. Relieve the pressure.
3. Remove the safety panel (39). See Fig. 13. Disconnect the inlet and outlet fluid hoses of the secondary displacement pump (124).

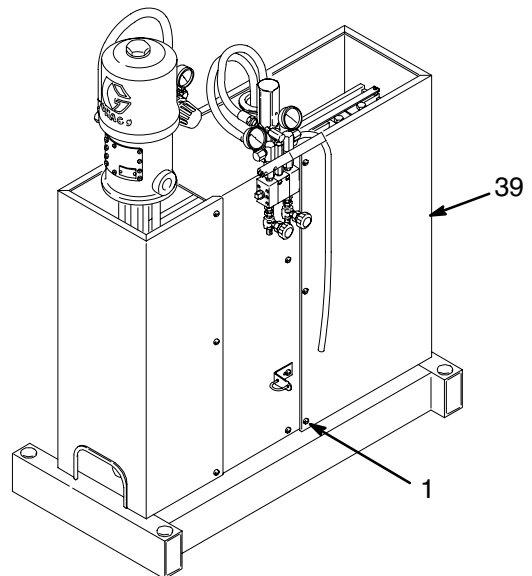

Fig. 13

02366A

Continued on page 23.

Service

NOTE: Refer to Fig. 14 for steps 4 to 10.

4. Push down on the lever arm (49) until the wrench flats (KK) on the secondary pump (124) are just above the wet-cup (LL). Remove the ratio index clamp capscrews (16a) and the index clamp (30).

NOTE: Some fluid will drip from the pump when you are removing the ratio index clamp.

5. Raise the lever arm (49) off the pivot pin support (31a).
6. Remove the connecting rod cotter pin (102), if the pump has one. Unscrew the connecting rod assembly (117, 14a, 34a, 31a) in one piece from the pump.
7. If you are removing only the pump, remove it from the inlet manifold (32). If the secondary pump(s) need repair, follow the instructions in its manual.
8. If you are removing the bearings and pins, tilt the secondary pump (124) forward until it rests on the floor. Then follow Steps 9 and/or 10.
9. If you are removing the upper bearing (14a) and support pin:
 - a. Loosen the two setscrews (17a). Back out the setscrews far enough to clear the countersinks of the support pin (34a).
 - b. Place the support (31a) in a vise. Unscrew the connecting rod (117) from the bearing (14a). The connecting rod and bearing are sealed with thread sealant and may be difficult to unscrew.
 - c. Remove the support (31a) from the vise. Gently tap the support pin (34a) out with a hammer and punch.
 - d. Replace the support pin and bearing.
10. If removing the lower bearing (14b) and support pin (34b):
 - a. Remove one of the lower clamps (28) and capscrews (16b).
 - b. Loosen the locknut (3) and screw the pump manifold (32) off the bearing (14b) to remove the secondary displacement pump (124).
 - c. Remove the remaining clamp (28) and cap-screw (16b) from the lower support (31b).

- d. Raise the VRHC lower frame (50) and remove the support (31b).
- e. Gently tap the support pin (34b) out with a hammer and punch.
- f. Replace the pin and bearing.

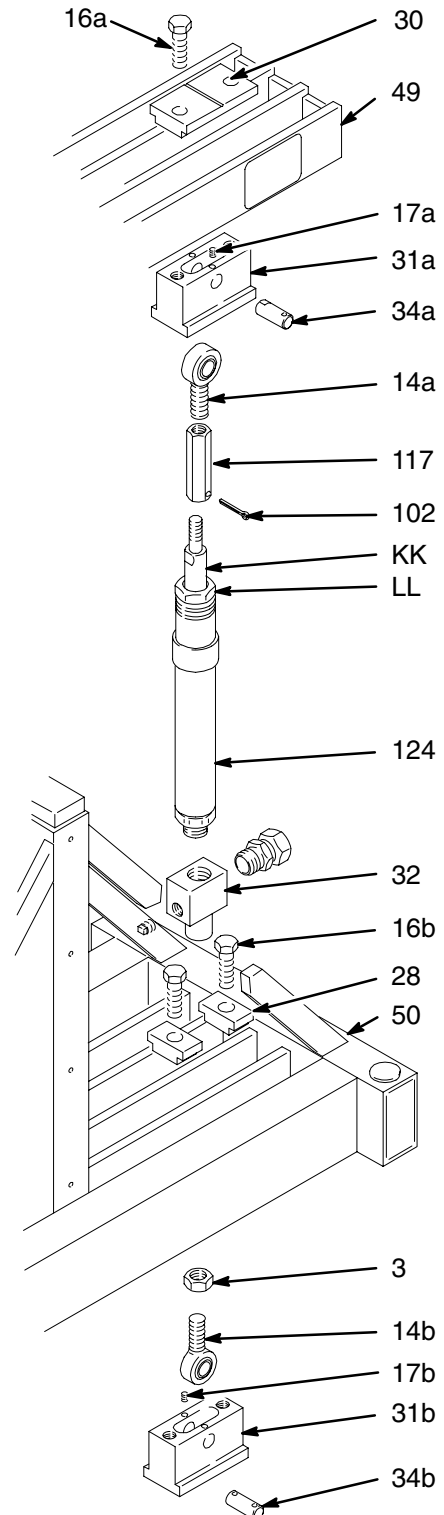

Fig. 14

02374

Service

Replacing the Secondary Pump and/or the Bearings and Pins

NOTE: Refer to Fig. 14 for Steps 1 to 3.

1. If only the secondary pump is being replaced:
 - a. Screw the secondary pump (124) into the inlet manifold (32). The manifold must face the end of the VRHC as shown in Fig. 14. If it does not, rotate the secondary displacement pump until it does, and tighten the locknut (3) against the inlet manifold. Torque the locknut to 60 ft-lb (81 N.m).
 - b. Replace the connecting rod assembly (117, 14a, 34a, 31a) onto the displacement rod, and line up the cotter pin holes. Insert the cotter pin (102).
 - c. Raise the lever arm (49) and place the support (31a) under the proper slot.
 - d. Push down the lever arm until the support fits into the slot. If the support does not line up with the slot, rotate it clockwise until it does.
 - e. Place the ratio index clamp (30) over the top of the support (31a). Insert the capscrews (16a).
 - f. Set the index clamp (30) for the proper ratio and tighten the capscrews (16a).
2. If replacing the lower bearing (14b) and support pin (34b):
 - a. Place a generous amount of Graco Gear Reducer Oil (43) on the inside of the lower bearing (14b) and the surface of the support pin (34b).
 - b. Screw the locknut (3) onto the bearing (14b) threads until the locknut bottoms out.
 - c. Slide the bearing into the slot in the support (31b). Insert the pin (34b) into place with the countersinks under the setscrew (17) holes. Tighten the setscrews to 35 in-lb (4 N.m). These are 10–32 self-locking setscrews. If no drag is felt while turning, replace the setscrew.

- d. Screw the secondary displacement pump (124) and manifold (32) onto the bearing (14b) until it bottoms out. Be sure it is not resting against the locknut (3).
 - e. Align and loosely install the two clamps (28) and capscrews (16b).
3. If replacing the upper bearing (14a) and support pin (34a):
 - a. Place a generous amount of Graco Gear Reducer Oil (43) on the inside of the upper bearing (14a) and the surface of the support pin (34a).
 - b. Slide the support (31a) onto the bearing (14a). Insert the support pin (34a) with the countersinks in place under the setscrew (17a) holes.

CAUTION

Do not force the pin into place. Check for burrs on the pin or in the VRHC frame if the pin does not slide into place.

- c. Tighten the setscrews (17a) to 35 in-lb (4 N.m). These are 10–32 self-locking screws. If no drag is felt while turning, replace the setscrews.
 - d. Place the support (31a) in a vise and screw the connecting rod (117) onto the bearing (14a). The connecting rod and the bearing can be disassembled and then reused one time before needing replacement. Be sure to seal the connecting rod and the bearing with thread sealant such as Loctite® No. 27105 or the equivalent. Apply 3 drops of the sealant to the threads of the bearing.
 - e. Screw the connecting rod (117) onto the pump (124) until the cotter pin holes line up (if the displacement pump has them). Install the cotter pin (102) and tighten the connecting rod against the piston shoulder of the displacement rod.
 - f. Follow steps 1.c to 1.f at left.
 - g. Tighten the capscrews (16b) at the bottom of the secondary displacement pump (124).

Service

Removing the Primary Pump and/or the Lower Bearing and Pin

1. Flush the entire system with a compatible solvent.

⚠ WARNING

To reduce the risk of serious injury whenever you are instructed to relieve pressure, always follow the **Pressure Relief Procedure** on page 15.

2. Relieve the pressure.
3. Remove the safety panels (39,40). Disconnect the inlet and outlet hoses on the primary displacement pump (123).

NOTE: Refer to Fig. 15 for Steps 4 to 6.

4. Remove the three tie rod locknuts (103) and push up on the air motor (118) until the tie rods (116) clear the mounting holes of the displacement pump. See Fig. 15.
5. Using a wrench on the flats of the tie rods, unscrew them from the air motor base.
6. Remove the upper cotter pin (102c) and unscrew the air motor from the connecting rod (121).

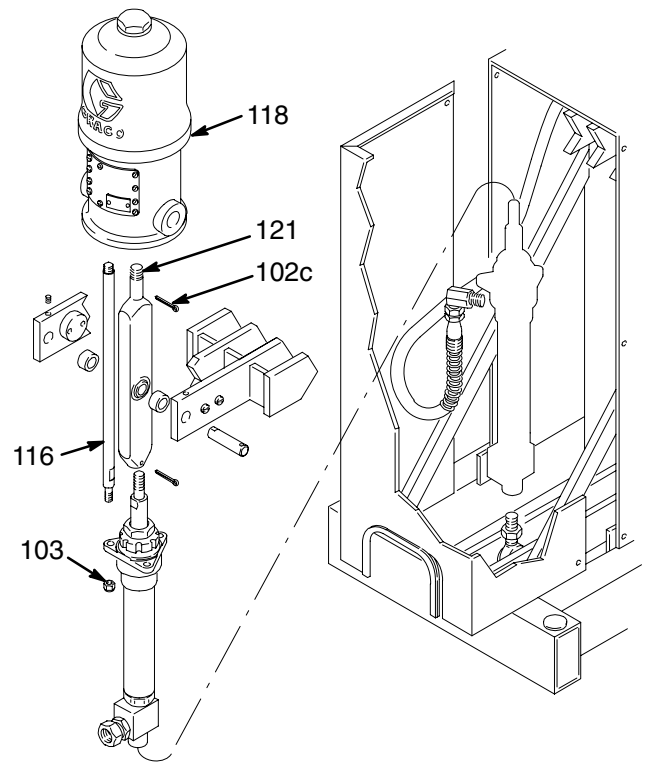

Fig. 15

02375A

Continued on page 26.

Service

NOTE: If only the motor needs repair, follow the instructions in the appropriate manual.

NOTE: Refer to Fig. 16 for Steps 7 to 15.

7. Remove the lower cotter pin (102d) from the connecting rod (121) (if the pump has one) and loosen the two setscrews (59). The setscrews must be backed out far enough to clear the countersink of the bearing support pin (35c).
8. Hold the connecting rod (121) and gently tap out the support pin (35c) with a hammer and punch.
9. Slowly pull the connecting rod (121) away from the lever arm (49) and tilt the pump (123) forward until it rests on the frame. Save the two nylon spacers (27c).
10. Unscrew the connecting rod (121) from the displacement pump (123). If necessary, replace the connecting rod.
11. If removing the pump only, remove it from the manifold (32). If the primary pump needs repair, follow the instructions in the separate pump manual.
12. If removing the lower bearing (14d) and pin (35d), tilt the primary pump (123) forward until it rests on the floor. Then follow steps 13 to 15.
13. Loosen the lower rod end locknut (3) and unscrew the pump manifold (32) to remove the primary pump (123).
14. Loosen the two setscrews (17b). The setscrews must be backed out far enough to clear the countersinks of the support pin (35d).
15. Remove the pin (35d) and save the two nylon spacers (27d) and the bearing (14d).

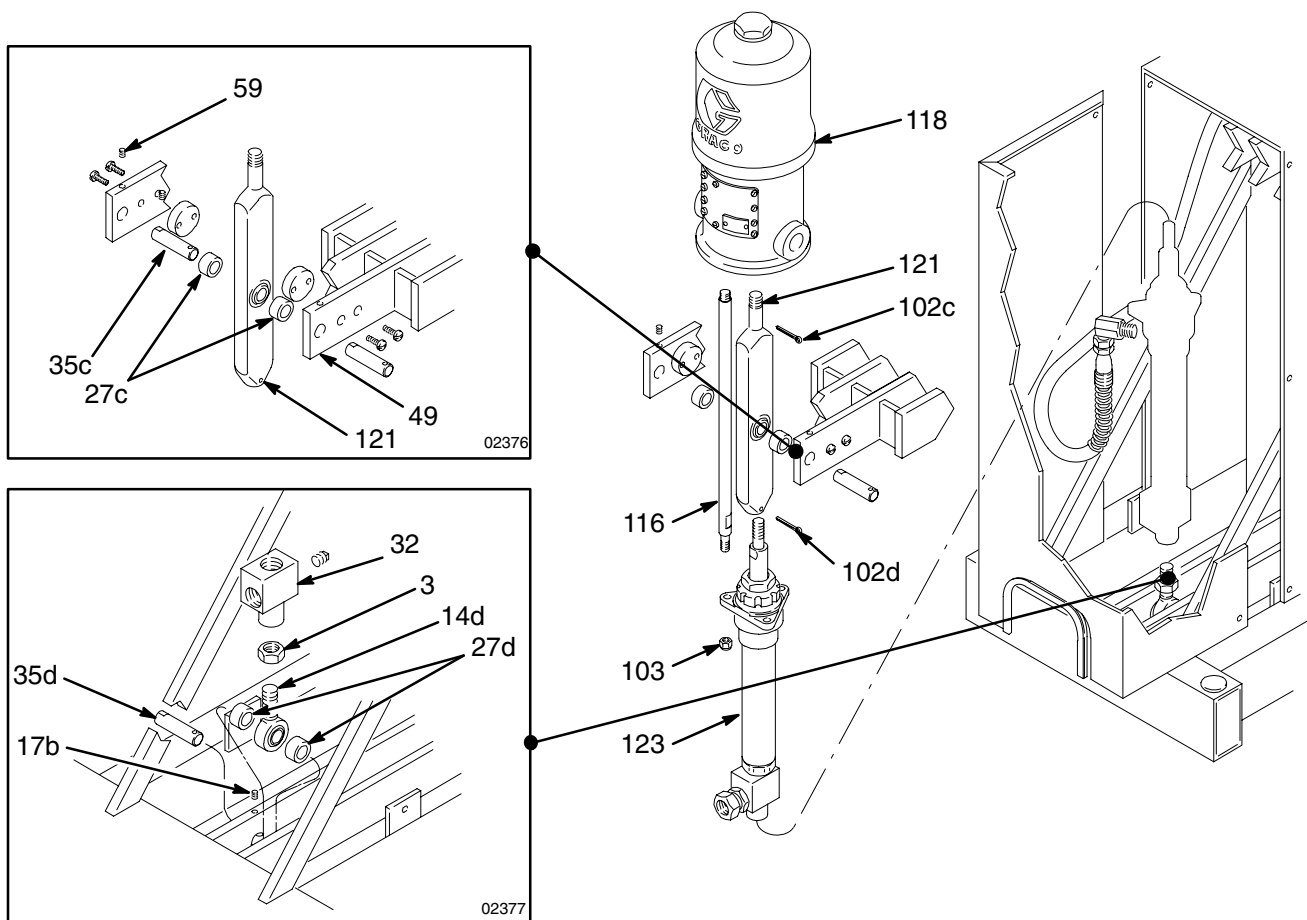

Fig. 16

02375A

Service

Replacing the Primary Pump and/or Bearing and Pins

NOTE: Refer to Fig. 17 for Steps 1 to 9 except where noted.

1. Screw the displacement pump (123) into the inlet manifold (32) so the outlet is facing the back.
2. Screw the connecting rod (121) onto the primary displacement pump until the cotter pin holes line up. Install the cotter pin (102d) if the pump has one; if not, bottom out the connecting rod on the displacement pump.
3. Pull the connecting rod upward until the displacement pump stops.
4. Screw the air motor (118) onto the connecting rod until the cotter pin holes line up. Install the cotter pin (102c).
5. Rotate the air motor until the air inlet port is on the same side as the air inlet manifold (37).
6. Screw the three tie rods (116) into the air motor base and torque to 35–50 ft-lb (47–68 N.m).

NOTE: One of the tie rods will run through the lever arm slot.

7. Push down the air motor and place the tie rods into the displacement pump tie plate. Tighten the tie rod locknuts (103).
8. To install the support pin (35c) into the upper bearing:
 - a. Remove the two capscrews (16a) from the support (31a) on the secondary pump (124).
 - b. Move the lever arm (49) until you can place the nylon spacers (27c) and support pin (35c) in line with the bearing in the connecting rod (121).
 - c. Lubricate the support pin with Gear Reducer Oil (43) and tap it into the upper bearing with the countersinks facing up.

⚠ CAUTION

Do not force the pin into place. Check for burrs on the pin or in the VRHC frame if the pin does not slide into place. Sand with 500 grit sandpaper between the countersinks.

- d. Torque the two setscrews (59) to 35 in-lb (4 N.m). See Fig. 18 on page 29.
- e. Move the lever arm (49) back into place and reinstall the two capscrews (16a) onto the support (31a) of the secondary pump.

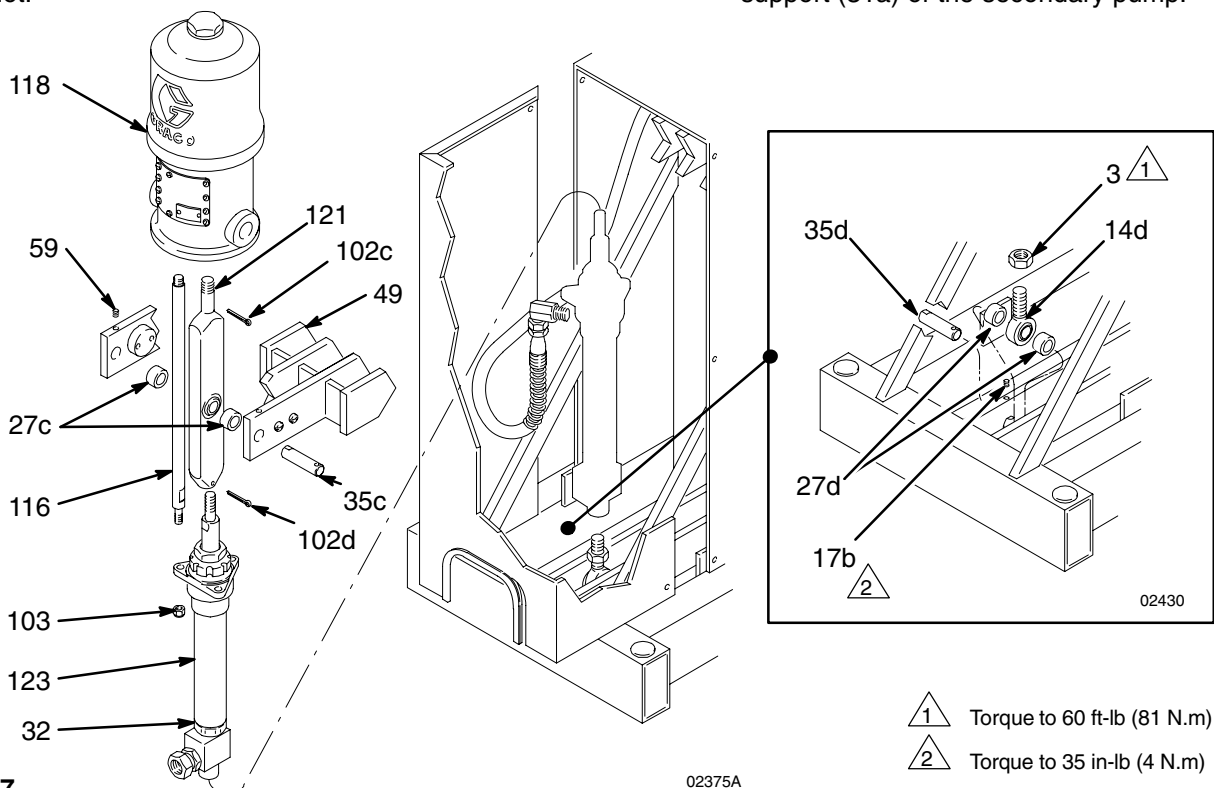

Fig. 17

Service

9. If replacing the lower bearing (14d) and pin (35d):
 - a. Thread the locknut (3) all the way onto the bearing.
 - b. Screw the inlet manifold (32) onto the bearing twelve turns and tighten the locknut up to the inlet manifold. Torque to 60 ft-lb (81 N.m).
 - c. Lubricate the support pin (35d) with Gear Reducer Oil (43). Install the pin with the countersinks facing up, into one side of the frame base (50). Place one nylon spacer (27d) on the end of the support pin.
 - d. Install the bearing (14d) and manifold (32) and align them with the support pin (35d).
 - e. Tap the pin in flush with the opposite side of the frame. Align the second nylon spacer with the support pin, and tap the pin all the way into the side of the frame base (50).
 - f. Tighten the two setscrews (17b) onto the support pin (35d). Torque to 35 in-lb (4 N.m).
 - g. Follow the procedure for replacing the primary pump on page 27.

Replacing the Lever Arm on the Frame

CAUTION

Tolerances between the surface of the frame and bearing are very close. Do not force the pin into place. Check for burrs on the pin or in the VRHC frame if the pin does not slide into place. Sand with 500 grit sandpaper between the countersinks.

NOTE: Refer to Fig. 18 for Steps 1 to 5.

1. Screw the locknuts (2) onto the pivot bearing (15).
2. Screw the pivot bearing into the frame base (50). Adjust the distance from the top of the support pin (33) to the bottom of the frame (50) to 26.125" (664 mm).
3. With the bearings at the correct height and parallel to each other, torque the locknuts (2) to 60 ft-lb (81 N.m).
4. Place a generous amount of lubricant (43) onto the support pin, and place the lever arm (49) over the bearings (15).
5. Slide the support pin, with the countersinks up, through the lever arm and bearings. Torque the two setscrews (17) to 35 in-lb (4 N.m).

NOTE: If no drag is felt while turning the setscrews, replace them.

Service

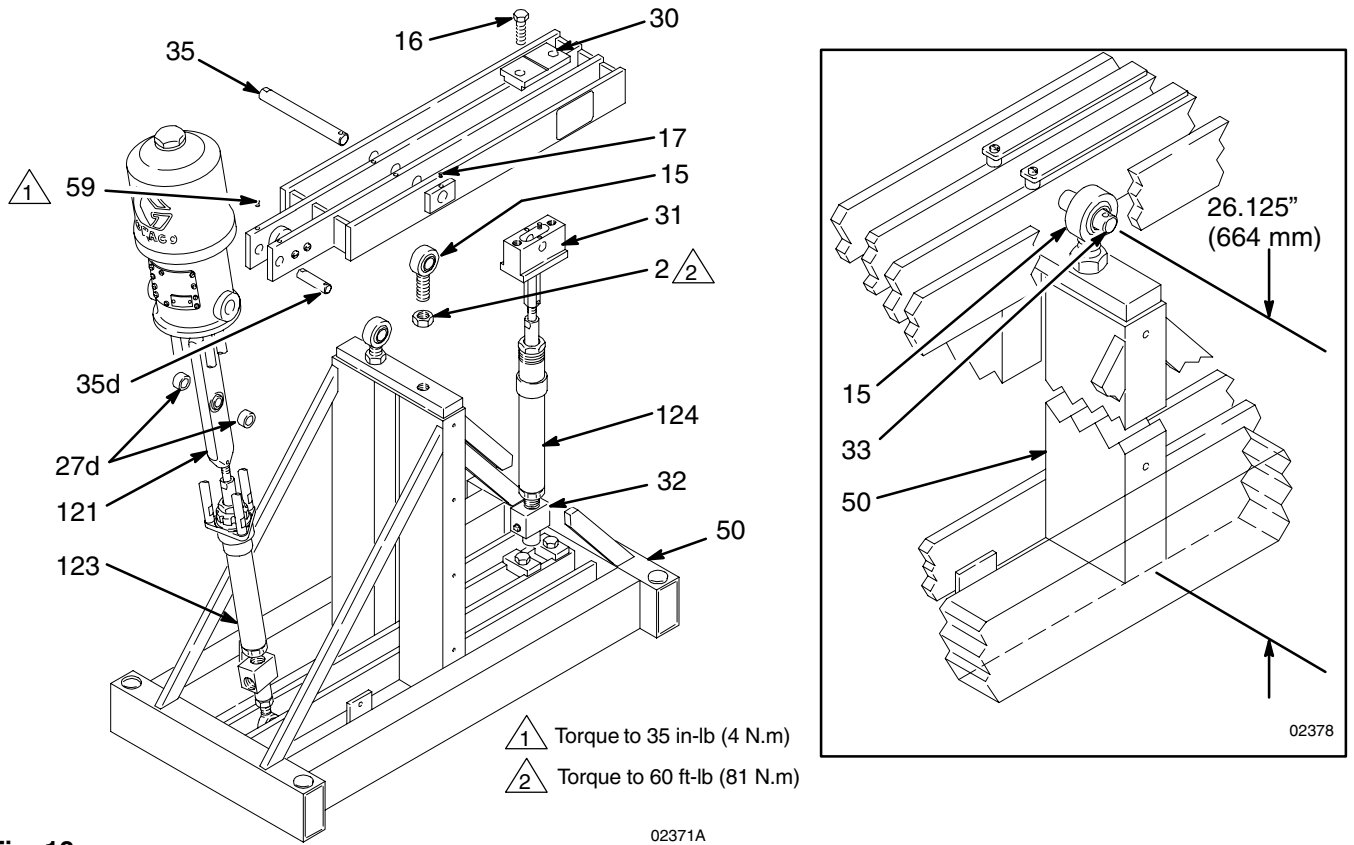
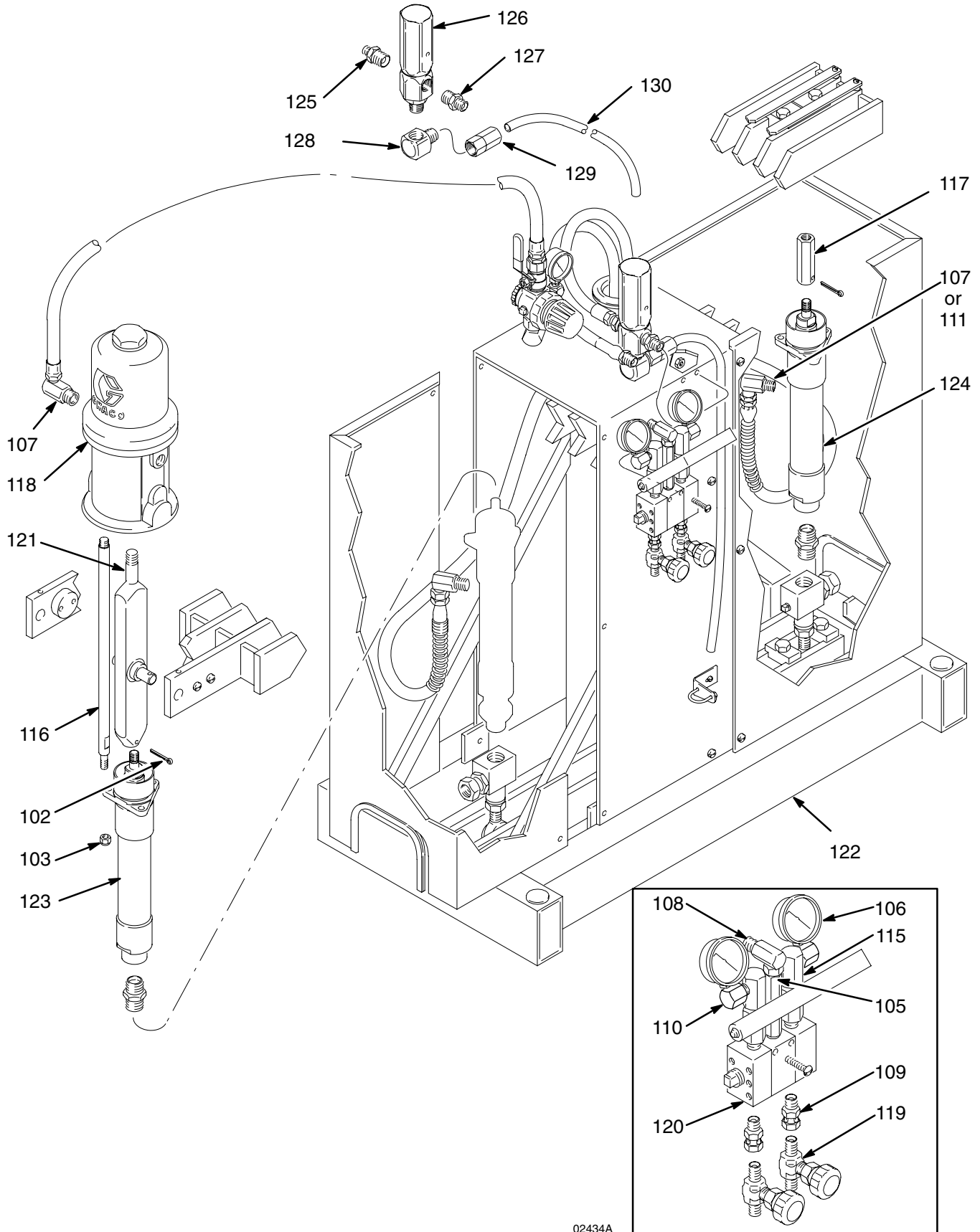

Fig. 18

Parts

For Monark Options A01, M01, and Q01



02434A

Parts

For Monark Options A01, M01, and Q01

Ref. No.	Part No.	Description	Qty.	Ref. No.	Part No.	Description	Qty.
102	100103	PIN, cotter	3	119	108233	SAMPLE VALVE, needle	2
103	101566	LOCKNUT, 3/8–16	3	120	215626	MANIFOLD	1
104	104088	RIVET	2			<i>See parts in manual 307400</i>	
105	100139	PLUG, pipe, 1/8 npt	2	121	215693	CONNECTING ROD	1
106	105770	FLUID PRESSURE GAUGE, 1000 psi (70 bar), 1/4 npt(m)	2	122	215925	12.67 inch (321.8 mm) long UNIT FRAME	1
107	155494	UNION, 3/8 npt(m) x 3/8 npt(f)	1			<i>see parts on pages 32 to 35</i>	
108	155541	SWIVEL UNION, 90°, 1/4 npt(m) x 1/4 npsm(f)	1	123	215932	PRIMARY DISPL. PUMP	1
109	156823	UNION, 1/4 npt(m x f)	2	124	222015	SECONDARY DISPL. PUMP	1
110	158962	ELBOW, street, 1/4 npt(f) x 1/8 npt(m)	2			<i>Used in M01 Option</i>	
111	161037	SWIVEL UNION, 1/2 npt(m) x 3/8 npsm (f)	1		215932	SECONDARY DISPL. PUMP	1
114	172446	PLATE, designation	1			<i>Used in A01 Option</i>	
115	177088	SWIVEL UNION, 3/8 npt(f) x 3/8 npsm(f), two 1/8 npt(f) ports	2		222019	SECONDARY DISPL. PUMP	1
116	177109	TIE ROD, 15.81 inch (401.6 mm) shoulder-to-shoulder	3			<i>Used in Q01 Option</i>	
117	177114	CONNECTING ROD, 2.535 inch (64.4 mm) long	1	125	162449	NIPPLE, 1/2 x 1/4	1
	177113	CONNECTING ROD 2.62 inch (66.5 mm) long	1	126	237060	RELIEF VALVE 475 (33) to 575 (400) psi (bar) working pressure	1
		<i>used in M01 and Q01 Options</i>		127	159239	NIPPLE, 3/8 x 1/2	1
118	205997	AIR MOTOR, Monark	1	128	158683	ELBOW 90°, 1/2 x 1/2	1
		<i>See parts in manual 308043</i>		129	113187	CONNECTOR, female, tube	1
				130	190738	TUBE, nylon	1

Parts

Unit Frame All Options

1 Torque to 35 in-lb (4 N.m)

2 Torque to 60 ft-lb (81 N.m)

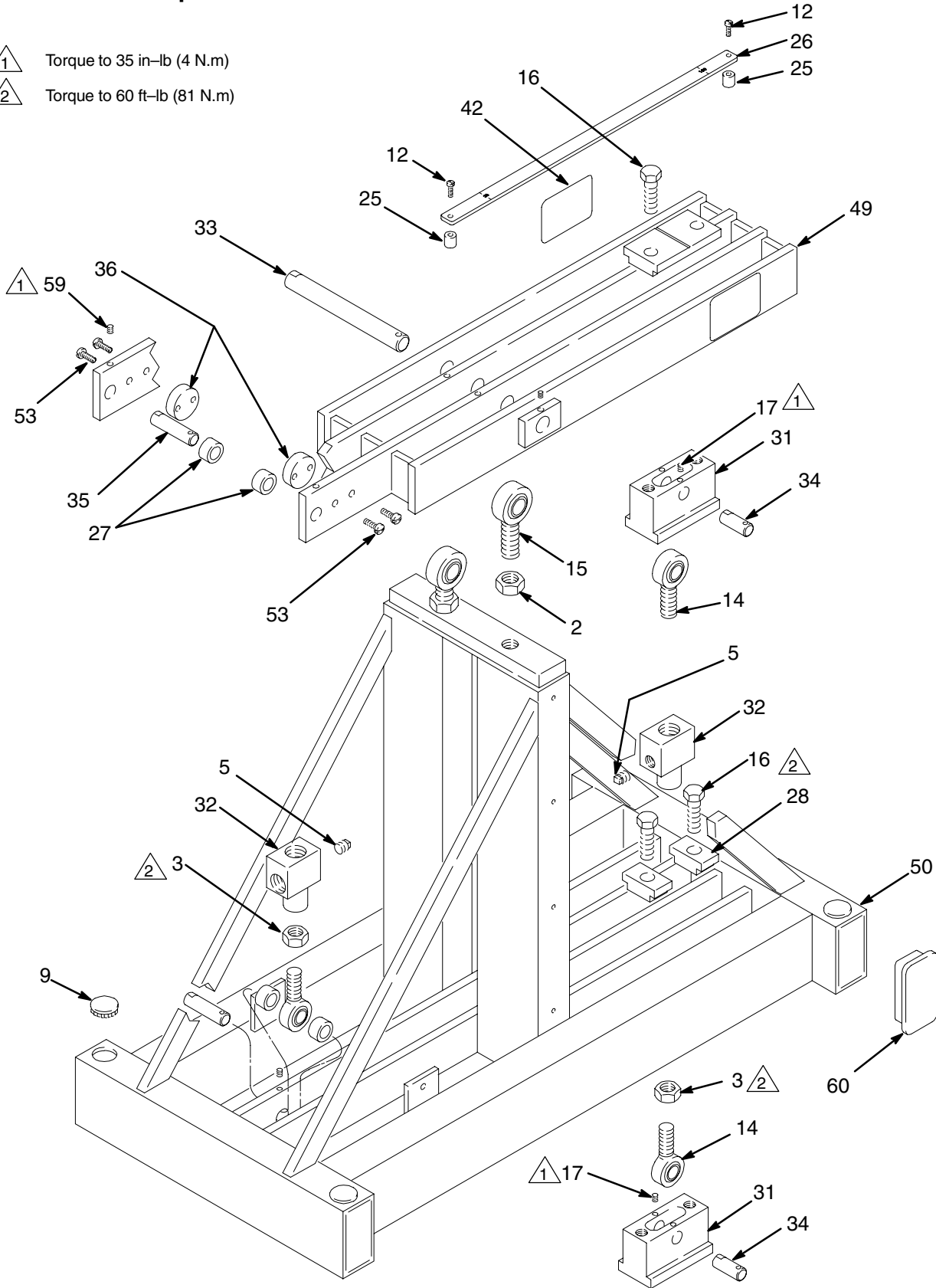

02432A

Parts

Unit Frame All Options

Ref. No.	Part No.	Description	Qty.	Ref. No.	Part No.	Description	Qty.
2	100071	LOCKNUT, hex, 3/4-16	2	32	177101	MANIFOLD, inlet	2
3	100155	NUT, 5/8-18	2	33	177105	PIN, pivot, frame	1
5	100509	PLUG, pipe, 1/4 npt	3	34	177106	PIN, pivot, housing	2
9	101747	PLUG, bottom, 1/4 npt(m)	4	35	177107	PIN, pivot, pump	2
12	103836	SCREW, slotted head, 10-32 x 3/4 in. (19 mm)	12	36	177108	PLATE, wear	2
14	105751	BEARING, rod end	3	42▲	177144	LABEL, WARNING	4
15	105752	BEARING, rod end	2	44	206994	THROAT SEAL LIQUID (not shown)	8 ounces
16	100060	CAPSCREW, hex head, 1/2-13 x 1-3/4 inch (44 mm)	4	49	215664	ARM, lever	1
17	105762	SETSCREW, 10-32	8	50	215665	FRAME BASE, VRHC	1
25	159463	SPACER	4	52	061135	HOSE, nylon (not shown)	1.5 feet
26	177042	GAUGE, designation	2	53	102790	SCREW, 10-24	4
27	177086	SPACER, 1/4, nylon	4	59	108038	SETSCREW, 10-32	2
28	177089	CLAMP, lower	2	60	189559	CAP, end	4
30	177099	CLAMP, top, index	1				
31	177100	SUPPORT, pivot pin	2				

▲ Replacement Danger and Warning labels, tags and cards are available at no cost.

Parts

Unit Frame All Options

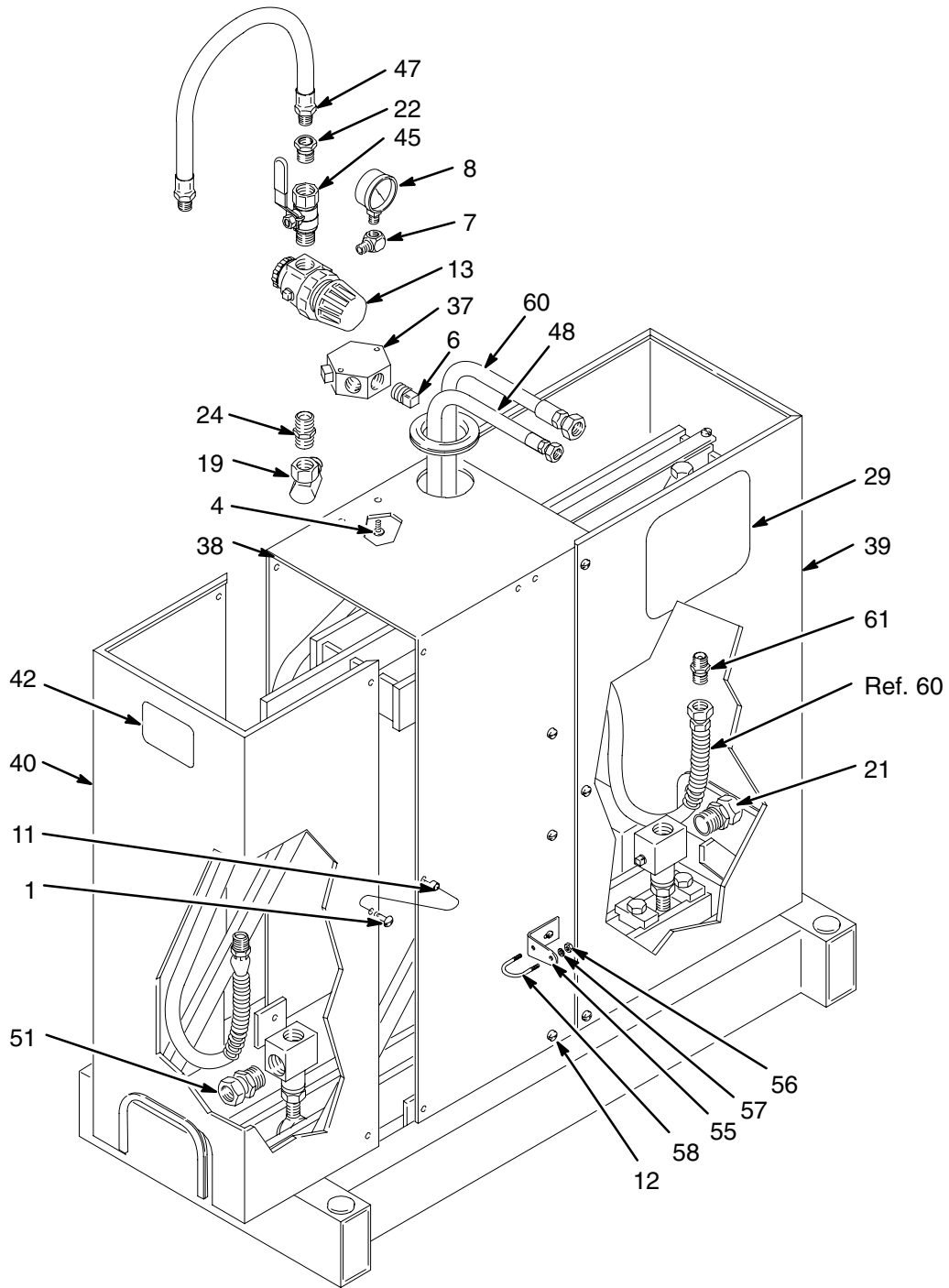

02433A

Parts

Unit Frame All Options

Ref. No.	Part No.	Description	Qty.	Ref. No.	Part No.	Description	Qty.
1	108036	STUD, fastener	12	38	177118	PANEL, safety	1
4	100377	SCREW, slotted head, 1/4–20 x 5/8 in. (16 mm)	2	39	177119	PANEL, safety	1
6	100737	PLUG, pipe, 1/2 npt	4	40	177120	PANEL, safety	1
7	100840	ELBOW, street, 1/4 npt (m x f)	1	42▲	177144	LABEL, WARNING	4
8	100960	GAUGE, air pressure, 0–200 psi (0–14 bar)	1	45	107142	AIR VALVE, bleed–type master	1
11	108037	NUT, sheet spring, 10–24	12	47	214652	HOSE, buna–s, 1/2 in. (13 mm) ID, coupled 3/8 npt(mbe), 1.5 ft (0.45 m) long	1
12	103836	SCREW, slotted head, 10–32 x 3/4 in. (19 mm)	12	48	H53806	HOSE, nylon; 3/8 (10 mm) ID; 3/8 npsm(fbe); 6 ft (1.8 m) long	1
13	104267	AIR REGULATOR, 1/2 npt(f) inlet and outlet, 1/4 npt(f) gauge ports 0–125 psi (0–8 bar) range. See manual 307204	1	51	062035	MOLDING, rubber	1.8 feet
19	155470	SWIVEL UNION, 90°, 1/2 npt(m) x 1/2 npsm(f) swivel	1	55	180673	BRACKET	1
21	157785	SWIVEL UNION, straight, 3/4 npt(m) x 1/2 npsm(f) swivel	2	56	100179	NUT, 10–24	2
22	100081	BUSHING, 3/8 npt(f) x 1/2 npt(m)	1	57	100718	WASHER, no. 10	2
23	158244	GROMMET	1	58	180674	U–BOLT, 10–24	1
24	158491	NIPPLE, 1/2 npt	1	60	223778	HOSE, PTFE, 1/4 in. (6 mm) ID, coupled 1/4 npsm(fbe), 5 ft (1.8 m) long	1
29▲	177096	LABEL, WARNING	1	61	164672	ADAPTER, 3/8 npt x 1/4 npsm(mbe)	1
37	177117	MANIFOLD, air	1				

▲ Replacement Danger and Warning labels, tags and cards are available at no cost.

Parts

All President Options

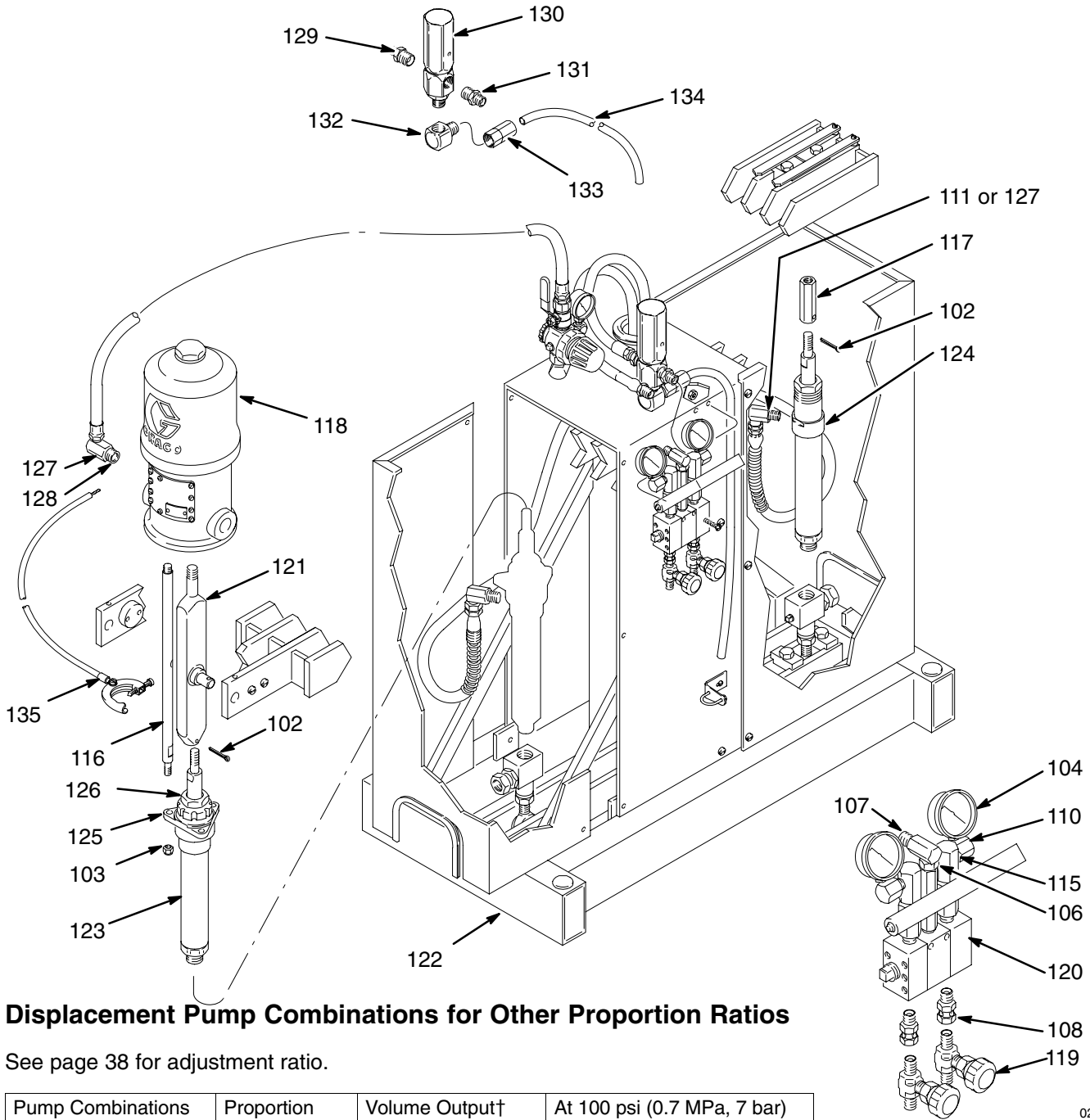

Displacement Pump Combinations for Other Proportion Ratios

See page 38 for adjustment ratio.

Pump Combinations		Proportion Ratio†	Volume Output‡ gpm (l/min.)‡	At 100 psi (0.7 MPa, 7 bar) psi (MPa, bar)†
Primary	Secondary			
222012	222015	1.2:1 to 5.6:1	1.10 to 0.70 (4.2 to 2.6)	1300 to 2200 (9 to 15, 90 to 152)
222012	222017	1.4:1 to 6.7:1	1.10 to 0.70 (4.2 to 2.6)	1400 to 2200 (9.7 to 15, 97 to 152)
222012	222019	1.9:1 to 9.0:1	1.10 to 0.70 (4.2 to 2.6)	1600 to 2300 (11 to 16, 110 to 159)

†Maximum to minimum ranges.

NOTE: Output pressure decreases as volume output increases.

‡Based on pump speed of 40 cycles per minute using No. 10 oil test media.

Parts

All President Options

Ref No.	Part No.	Description	Qty	Options	Ref No.	Part No.	Description	Qty	Options
102	100103	PIN, cotter	3	A04	122	215925	HOUSING, VRHC	1	All
			1	A06	123	215932	PRIM. DISPL. PUMP ¹	1	A04
				All		215930	PRIM. DISPL. PUMP ²	1	A06
				Others		222012	PRIM. DISPL. PUMP ³	1	A09
103	101566	LOCKNUT, sst, 3/8–16	3	All		222015	PRIM. DISPL. PUMP ³	1	A12
104	102814	GAUGE, pressure, 5000 psi (34 MPa, 350 bar), 1/4 npt(m)	2	All		222017	PRIM. DISPL. PUMP ³	1	A14
						222017	PRIM. DISPL. PUMP ³	1	D02
106	100139	PLUG, pipe, 1/8 npt	2	All		222015	PRIM. DISPL. PUMP ³	1	F06
107	155541	UNION, swivel, 90°, 1/4 npt(m) x 1/4 npsm(f)	1	All	124	215932	SEC. DISPL. PUMP ¹	1	A04
						215930	SEC. DISPL. PUMP ²	1	A06
						222012	SEC. DISPL. PUMP ³	1	A09
108	156823	UNION, 1/4 pt(m) x 1/4 npt(f)	2	All		222015	SEC. DISPL. PUMP ³	1	A12
						222017	SEC. DISPL. PUMP ³	1	A14
110	158962	ELBOW, street, 1/4 npt(f) x 1/8 npt(m)	2	All		222019	SEC. DISPL. PUMP ³	1	D02
						222019	SEC. DISPL. PUMP ³	1	F06
111	161037	UNION, swivel, 1/2 npt(f) x 3/8 npsm(f)	2	A04					
				A06	125	215690	MOUNTING PLATE	1	A09
115	177088	UNION, swivel, 3/8 npt(f) x 3/8 npsm(f)	2	All					A12
									A14
116	177111	TIE ROD, 16" (407 mm) shoulder to shoulder	3	A09					D02
				A12					F06
				A14					686632
				D02	126	164417	LOCKNUT	1	A09
				F06					A12
				686632					A14
	177112	TIE ROD, 15.2" (385 mm) shoulder to shoulder	3	A04					D02
									F06
									686632
	177471	TIE ROD, 16.9" (429 mm) shoulder to shoulder	3	A06	127	155494	UNION, 3/8 npt(mxf)	1	A04
									A06
								3	All
									others
117	177113	CONNECTING ROD, 2.62" (66.5 mm) long	1	A09	128	158212	BUSHING, 1/2 npt(m) x 3/8 npt(f)	1	All
				A12					
				A14	129	162449	NIPPLE, 1/2 x 1/4 npt	1	All
				D02	130	237063	VALVE, relief, 2900 to 3600 psi (20 to 24.8 MPa, 200 to 248 bar)	1	All
				F06					
				686632					
	177114	CONNECTING ROD, 2.5" (64.4 mm) long	1	A04	131	159239	NIPPLE, 3/8 x 1/2 npt	1	All
					132	158683	ELBOW, 90°, steel	1	All
	177115	CONNECTING ROD, 3.39" (88.1 mm) long	1	A06	133	113187	CONNECTOR, female, tube	1	All
118	207352	MOTOR, President ⁵	1	All					
119	108233	SAMPLING VALVE, needle	2	All	134	190738	TUBE, nylon	1	All
					135	237569	WIRE, ground	1	All
120	215626	MANIFOLD ⁴	1	All					
121	215691	CONNECTING ROD, 13.5" (342 mm)	1	A06					
	215692	CONNECTING ROD, 11.8" (300 mm)	1	A09					
				A12					
				A14					
				D02					
				F06					
				686632					
	215693	CONNECTING ROD, 12.7" (321 mm)	1	A04					

¹See manual 307430 for parts.

²See manual 307431 for parts.

³See manual 307944 for parts.

⁴See manual 307400 for parts.

⁵See manual 306982 for parts

Dimensions

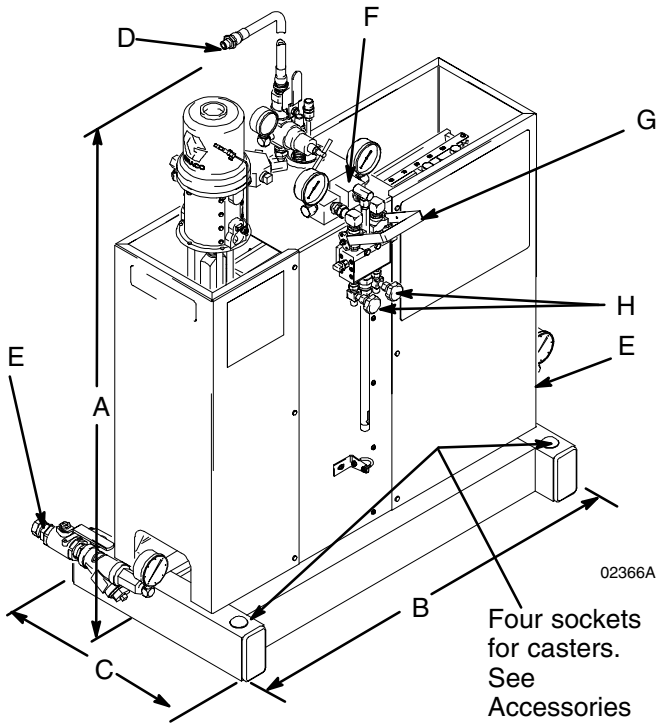

A Height	
President®	48.5" (1232 mm)
Viscount®	48.5" (1232 mm)
Monark®	45.6" (1156 mm)
Bulldog®	55.5" (1410 mm)
B Length	35" (889 mm)
C Width	18" (457 mm)
D Air Inlet	1/2 npt(f)
	has four 1/4 npt(f) plugged outlets
E Fluid Inlets	Two 3/4 npsm(f) swivel,
	has 1/4 npt(f) plugged cleanout port
F Solvent Inlets	1/2 npt(m)
G Fluid Outlet	1/2 npt(m)
H Valve Outlets	Two 1/4 npt(m)

Technical Data

Motor	Weight	Stroke Length	Effective Area
President®	19 lb (8.6 kg)	4 in (102 mm)	14.19 Sq in 91.55 cm
Monark®	13 lb (5.9 kg)	3 in (6 mm)	7.0 Sq in 45 cm ²
Bulldog®	78 lb (35.1 kg)	4.75 in (121 mm)	7.07 Sq in 45.61 cm
Viscount I®	18.5 lb (83 kg)	4 in (102 mm)	7.07 Sq in 45.61 cm

Wetted Parts – See Configurator Product Order Form 309025

Pump Model	Maximum Fluid Working Pressure	Maximum Pump Air Input Pressure
President®	250 bar, 25.0 MPa (3600 psi)	12.5 bar, 1.25 MPa (180 psi)
Monark®	125 bar, 12.5 MPa (1800 psi)	12.5 bar, 1.25 MPa (180 psi)
Bulldog®	347 bar, 34.7 MPa (4950 psi)	6.3 bar, 0.63 MPa (90 psi)

Pump Model	Air Pressure of Sound Tests (25 cycles/min)	* Sound Pressure Level	** Sound Power Level
President®	12.5 bar, 1.25 MPa (180 psi)	98 dBa	113 dBa
Monark®	12.5 bar, 1.25 MPa (180 psi)	96 dBa	112 dBa
Bulldog®	7 bar, 0.7 MPa (100 psi)	94 dBa	109 dBa

* Sound pressure was measured in accordance with Cagi Pneurop, 1969.

** Sound power was measured in accordance with ISO 3744, 1981.

Graco Standard Warranty

Graco warrants all equipment manufactured by Graco and bearing its name to be free from defects in material and workmanship on the date of sale by an authorized Graco distributor to the original purchaser for use. With the exception of any special, extended, or limited warranty published by Graco, Graco will, for a period of twelve months from the date of sale, repair or replace any part of the equipment determined by Graco to be defective. This warranty applies only when the equipment is installed, operated and maintained in accordance with Graco's written recommendations.

This warranty does not cover, and Graco shall not be liable for general wear and tear, or any malfunction, damage or wear caused by faulty installation, misapplication, abrasion, corrosion, inadequate or improper maintenance, negligence, accident, tampering, or substitution of non-Graco component parts. Nor shall Graco be liable for malfunction, damage or wear caused by the incompatibility of Graco equipment with structures, accessories, equipment or materials not supplied by Graco, or the improper design, manufacture, installation, operation or maintenance of structures, accessories, equipment or materials not supplied by Graco.

This warranty is conditioned upon the prepaid return of the equipment claimed to be defective to an authorized Graco distributor for verification of the claimed defect. If the claimed defect is verified, Graco will repair or replace free of charge any defective parts. The equipment will be returned to the original purchaser transportation prepaid. If inspection of the equipment does not disclose any defect in material or workmanship, repairs will be made at a reasonable charge, which charges may include the costs of parts, labor, and transportation.

THIS WARRANTY IS EXCLUSIVE, AND IS IN LIEU OF ANY OTHER WARRANTIES, EXPRESS OR IMPLIED, INCLUDING BUT NOT LIMITED TO WARRANTY OF MERCHANTABILITY OR WARRANTY OF FITNESS FOR A PARTICULAR PURPOSE.

Graco's sole obligation and buyer's sole remedy for any breach of warranty shall be as set forth above. The buyer agrees that no other remedy (including, but not limited to, incidental or consequential damages for lost profits, lost sales, injury to person or property, or any other incidental or consequential loss) shall be available. Any action for breach of warranty must be brought within two (2) years of the date of sale.

Graco makes no warranty, and disclaims all implied warranties of merchantability and fitness for a particular purpose in connection with accessories, equipment, materials or components sold but not manufactured by Graco. These items sold, but not manufactured by Graco (such as electric motors, switches, hose, etc.), are subject to the warranty, if any, of their manufacturer. Graco will provide purchaser with reasonable assistance in making any claim for breach of these warranties.

In no event will Graco be liable for indirect, incidental, special or consequential damages resulting from Graco supplying equipment hereunder, or the furnishing, performance, or use of any products or other goods sold hereto, whether due to a breach of contract, breach of warranty, the negligence of Graco, or otherwise.

FOR GRACO CANADA CUSTOMERS

The parties acknowledge that they have required that the present document, as well as all documents, notices and legal proceedings entered into, given or instituted pursuant hereto or relating directly or indirectly hereto, be drawn up in English. Les parties reconnaissent avoir convenu que la rédaction du présente document sera en Anglais, ainsi que tous documents, avis et procédures judiciaires exécutés, donnés ou intentés à la suite de ou en rapport, directement ou indirectement, avec les procédures concernées.

Graco Information

TO PLACE AN ORDER, contact your Graco distributor, or call one of the following numbers to identify the distributor closest to you:

1-800-328-0211 Toll Free

612-623-6921

612-378-3505 Fax

All written and visual data contained in this document reflects the latest product information available at the time of publication. Graco reserves the right to make changes at any time without notice.

MM 309024

Graco Headquarters: Minneapolis

International Offices: Belgium, China, Japan, Korea

GRACO INC. P.O. BOX 1441 MINNEAPOLIS, MN 55440-1441

www.graco.com

PRINTED IN USA 309024 July 1999 Rev. 02/2006