

# Instructions – Parts List



HIGH PRESSURE AIR-ASSISTED

## Alpha™ Plus AA Spray Gun 309117D

4000 psi (28 MPa, 280 bar) Maximum Working Fluid Pressure  
100 psi (0.7 MPa, 7 bar) Maximum Working Air Pressure

16 psi (110 kPa, 1.1 bar) Maximum Compliant Inbound Air Pressure  
(243575 HVLP Guns Only)

### Part No. 243573, Series A

Air-Assisted Spray Gun

### Part No. 243574, Series A

Hi-Flow Air-Assisted Spray Gun

### Part No. 243575, Series A

HVLP Air-Assisted Spray Gun with Compliant Air Cap

### Part No. 243576, Series A

AA Reverse-A-Clean® (RAC) Spray Gun

### Part No. 243577, Series A

Hi-Flow Reverse-A-Clean® (RAC) Spray Gun

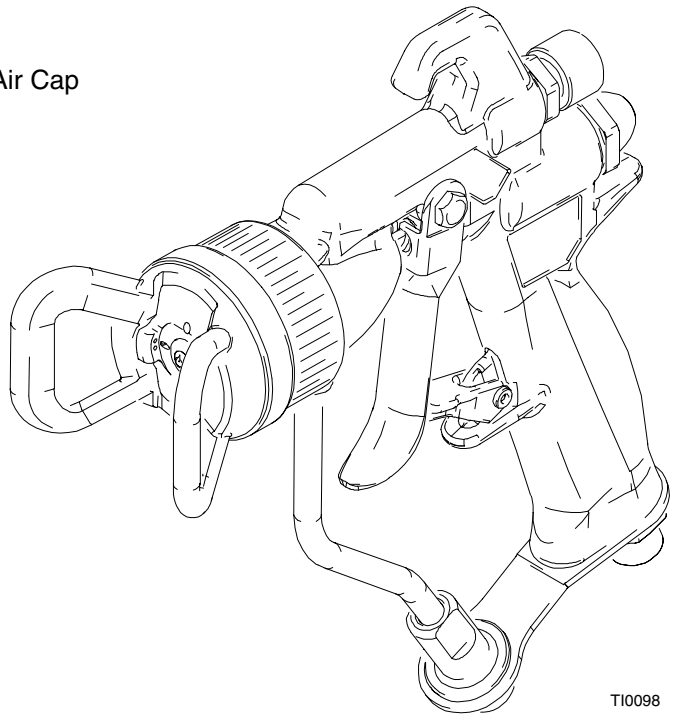

T10098



**Read warnings and instructions.**  
See page 2 for **Table of Contents.**

PROVEN QUALITY. LEADING TECHNOLOGY.

# Table of Contents

Warnings .....	2	Service .....	18
Air Flow Charts .....	4	Parts .....	22
Installation .....	5	Tip Selection Charts .....	26
Setup .....	7	Accessories .....	30
Operation .....	9	Technical Data .....	31
Daily Gun Care, Flushing, and Cleaning .....	12	Dimensions .....	31
General Troubleshooting .....	16	Warranty .....	32
Spray Pattern Troubleshooting .....	17	Graco Information .....	32

## WARNING



### INJECTION HAZARD

Spray from the gun, hose leaks, or ruptured components can inject fluid into your body and cause an extremely serious injury, including the need for amputation. Splashing fluid in the eyes or on the skin can also cause a serious injury.



- Fluid injected into the skin might look like just a cut, but it is a serious injury. **Get immediate medical attention.**
- Do not point the spray gun at anyone or at any part of the body.
- Do not put hand or fingers over the spray tip.
- Do not stop or deflect fluid leaks with your hand, body, glove, or rag.
- Do not “blow back” fluid; this is not an air spray gun.
- Check the gun diffuser operation weekly.
- Be sure the gun trigger safety operates before spraying.
- Lock the gun trigger safety when you stop spraying.
- Follow the **Pressure Relief Procedure** on page 9 whenever you: are instructed to relieve pressure; stop spraying; clean, check, or service the equipment; or install or clean the spray tip.
- Tighten all the fluid connections before operating the equipment.
- Check the hoses, tubes, and couplings daily. Replace worn, damaged, or loose parts immediately. Permanently coupled hoses cannot be repaired; replace the entire hose.



### TOXIC FLUID HAZARD

Hazardous fluids or toxic fumes can cause serious injury or death if splashed in the eyes or on the skin, swallowed, or inhaled.

- Know the specific hazards of the fluid you are using. Read the fluid manufacturer’s warnings.
- Store hazardous fluid in an approved container. Dispose of hazardous fluid according to all local, state and national guidelines.
- Wear the appropriate protective clothing, gloves, eyewear and respirator.

# WARNING



INSTRUCTIONS

## EQUIPMENT MISUSE HAZARD

Equipment misuse can cause the equipment to rupture, malfunction, or start unexpectedly and result in serious injury.

- This equipment is for professional use only.
- Read all instruction manuals, tags, and labels before operating the equipment.
- Use the equipment only for its intended purpose. If you are uncertain about usage, call your Graco distributor.
- Do not alter or modify this equipment. Use only genuine Graco parts and accessories.
- Check the equipment daily. Repair or replace worn or damaged parts immediately.
- Do not exceed the maximum working pressure of the lowest rated system component. This equipment has a **4000 psi (28 MPa, 280 bar) maximum working fluid pressure and a 100 psi (0.7 MPa, 7 bar) maximum incoming air pressure.**
- Route the hoses away from the traffic areas, sharp edges, moving parts, and hot surfaces. Do not expose Graco hoses to temperatures above 180°F (82°C) or below -40°F (-40°C).
- Do not use the hoses to pull the equipment.
- Use only Graco approved hoses. Do not remove hose spring guards, which help protect the hose from rupture caused by kinks or bends near the couplings.
- Use fluids or solvents that are compatible with the equipment wetted parts. See the **Technical Data** section of all the equipment manuals. Read the fluid and solvent manufacturer's warnings.
- Wear hearing protection when operating this equipment.
- Comply with all applicable local, state and national fire, electrical and other safety regulations.



## FIRE AND EXPLOSION HAZARD

Improper grounding, poor air ventilation, open flames, or sparks can cause a hazardous condition and result in fire or explosion and serious injury.

- Ground the equipment and the object being sprayed. See **Ground the System** on page 6.
- Provide fresh air ventilation to avoid the buildup of flammable fumes from solvent or the fluid being sprayed.
- Eliminate all ignition sources such as pilot lights, cigarettes and plastic drop cloths (static arc hazard). Do not plug or unplug power cords or turn lights on or off in the spray area.
- Keep the spray area free of debris, including solvent, rags, and gasoline.
- Do not turn on or off any light switch in the spray area while operating or if fumes are present.
- Do not smoke in the spray area.
- Do not operate a gasoline engine in the spray area.
- If there is any static sparking while using the equipment, **stop spraying immediately**. Identify and correct the problem.

# Air Flow Charts

## Gun Models 243573, 243574, 243576, and 243577

**KEY:** A = Fan valve open.  
B = Fan valve closed.

**Air Flow; Standard Air Cap 239781**

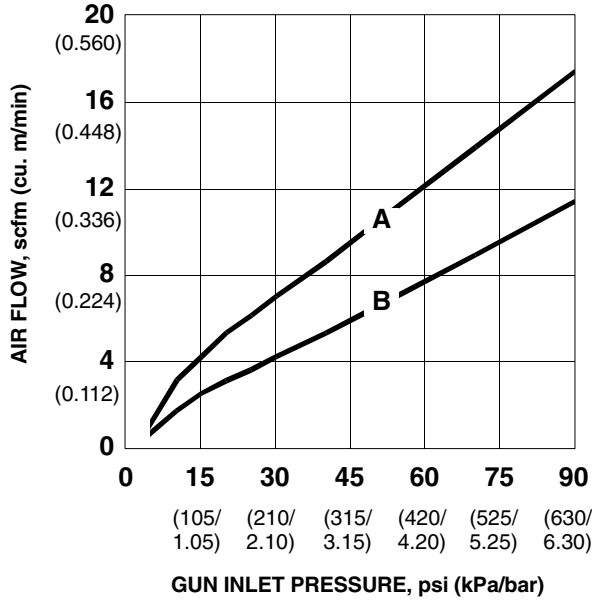

**Air Flow; AA RAC Air Cap 243570**

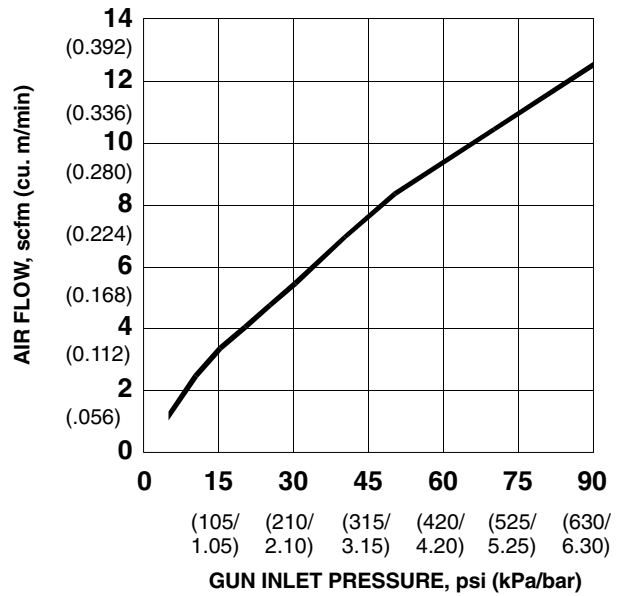

## HVLP Gun Model 243575

**KEY:** A = Fan valve open.  
B = Fan valve closed.

**Air Flow; Compliant Air Cap 239898**

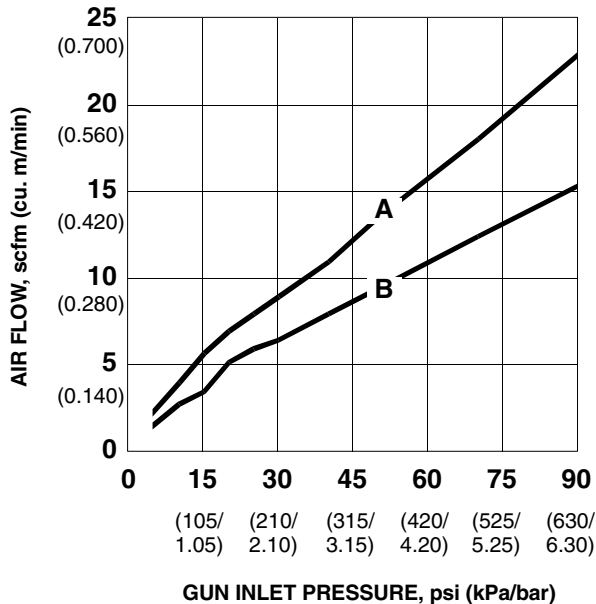

**Atomizing Air Pressure; Compliant Air Cap 239898**

*(inlet pressure versus atomizing pressure)*

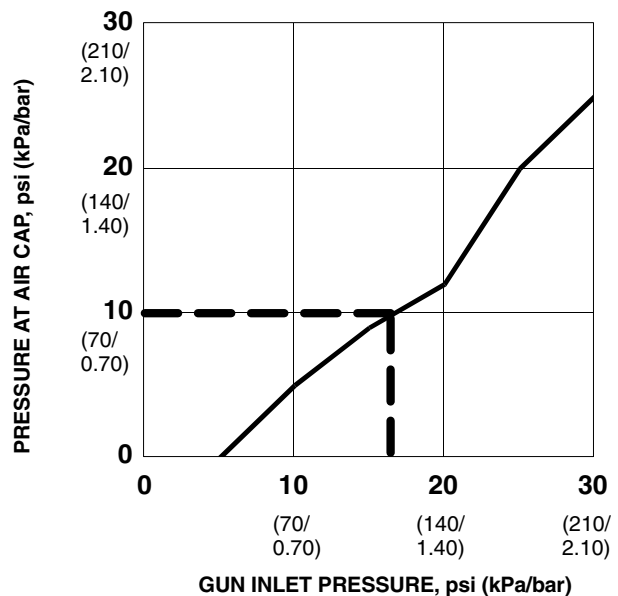

# Installation

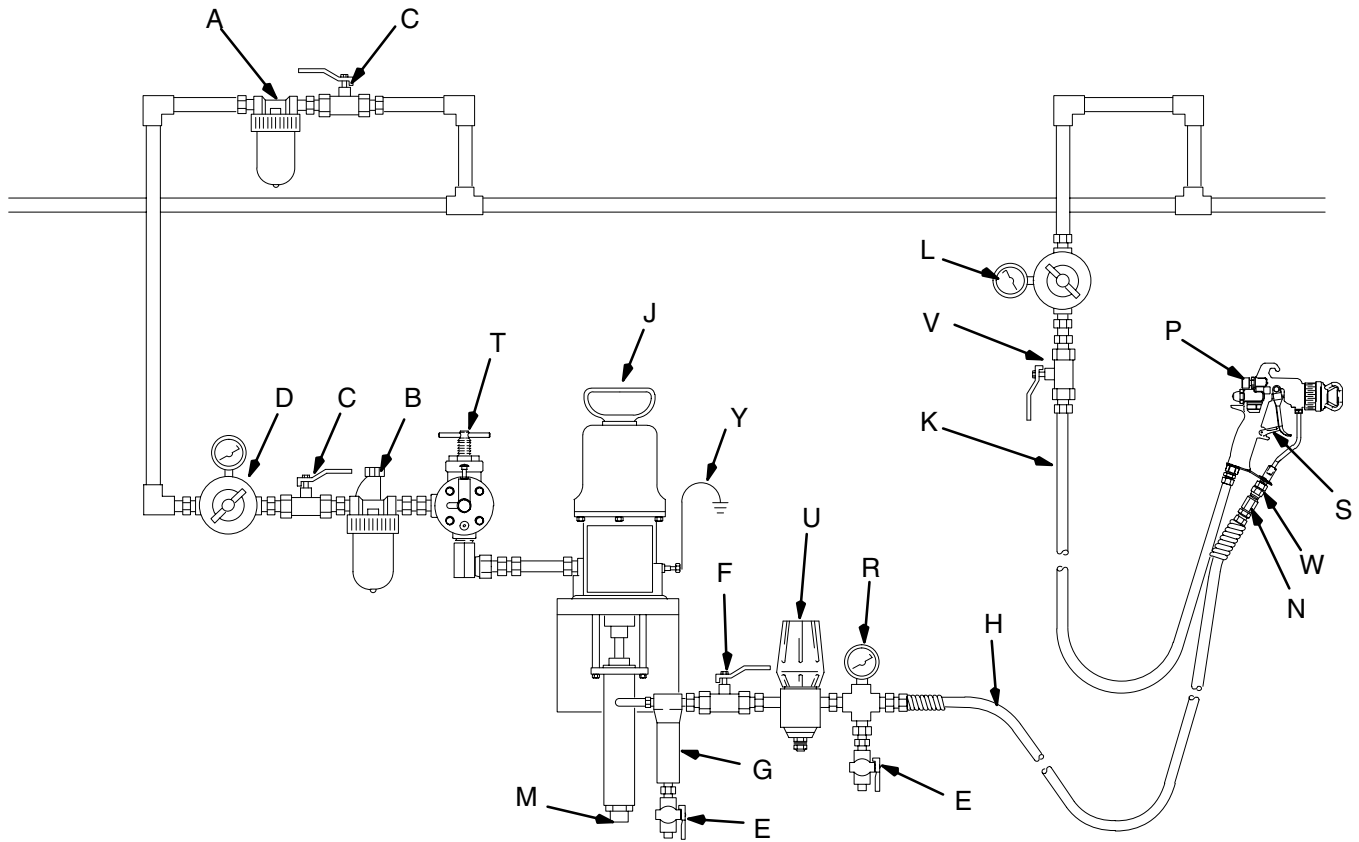

T10403

## KEY

- A Air Line Filter
- B Air Line Lubricator
- C\* Bleed-type Air Shutoff Valve
- D Pump Air Regulator
- E\* Fluid Drain Valve
- F Fluid Shutoff Valve
- G Fluid Filter

- H\* Grounded Fluid Hose
- J Pump
- K Air Line
- L Air Pressure Regulator
- M Pump Fluid Inlet
- N In-line Fluid Filter
- P Pattern Adjustment Valve Knob
- R Pressure Gauge

- S Trigger Safety
- T Pump Runaway Valve
- U\* Fluid Pressure Regulator
- V Air Shutoff Valve
- W Fluid Swivel
- Y\* Pump Ground Wire

*\*Equipment required for safe operation of the system. Must be purchased separately.*

Fig. 1

## Typical Installation

The typical installation shown in Fig. 1 is only a guide for selecting and installing air-assisted spray systems. Contact your Graco distributor for assistance in designing a system to meet your needs.

## Ventilate the Spray Booth

### **WARNING**



To prevent hazardous concentrations of toxic and/or flammable vapors, spray only in a properly ventilated spray booth. Do not operate the spray gun unless ventilation fans are operating.



Check and follow all of the National, State and Local codes regarding air exhaust velocity requirements.

Check and follow all local safety and fire codes.

# Installation

## Ground the System

### **WARNING**



#### **FIRE AND EXPLOSION HAZARD**

Improper grounding could cause static sparking, which could cause a fire or explosion. To reduce the risk of property damage or serious injury, follow the grounding instructions below.

The following grounding instructions are minimum requirements for a system. Your system may include other equipment or objects which must be grounded. Check your local electrical code for detailed grounding instructions for your area and type of equipment. Your system must be connected to a true earth ground.

1. **Pump:** Ground the pump by connecting a ground wire and clamp between the fluid supply and a true earth ground as instructed in your separate pump instruction manual.
2. **Air compressors and hydraulic power supplies:** Ground them according to the manufacturer recommendations.
3. **Air, fluid, and hydraulic hoses connected to the pump:** Use only electrically conductive hoses with a maximum of 500 feet (150 m) combined hose length to ensure grounding continuity. Check the electrical resistance of your air and fluid hoses at least once a week. If the total resistance to ground exceeds 29 megohms, replace the hose immediately.  
**NOTE:** Use a meter that is capable of measuring resistance at this level.
4. **Spray gun:** Ground the gun by connecting it to a properly grounded fluid hose and pump.
5. **Fluid supply container:** Ground it according to local code.
6. **Object being sprayed:** Ground it according to local code.
7. **All solvent pails used when flushing:** Ground them according to local code. Use only metal pails, which are conductive. Do not place the pail on a non-conductive surface, such as paper or cardboard, which interrupts the grounding continuity.
8. **To maintain grounding continuity when flushing or relieving pressure:** Always hold a metal part of the gun firmly to the side of a grounded metal pail, then trigger the gun.

# Setup

## 1. Connect the Air Line

### NOTE:

- You must install an air pressure regulator (L) on the gun air line to control air pressure to the gun. See Fig. 1.
- *If your regulated air source does not have a filter, install an air filter (A) on the air line to ensure a dry, clean air supply to the gun. Dirt and moisture can ruin the appearance of your finished workpiece.*
- Install an air pressure regulator (D) on the pump air supply line to control air pressure to the pump.
- Install a bleed-type air shutoff valve (C) on the main air line and on the pump air line, to shut off air to the pump.

### **WARNING**

The bleed-type air shutoff valve is required in your system to relieve air trapped between this valve and the pump after the air regulator is closed. Trapped air can cause the pump to cycle unexpectedly, which could result in serious injury.

- Use a 3/16 inch (5 mm) I.D. or larger air hose to minimize excessive pressure drop in the hose.

**NOTE:** The gun air inlet has a 1/4–18 npsm (R1/4–19) compound male thread that is compatible with npsm and bsp female swivel connectors.

- A. Install an air shutoff valve (V) on each gun air supply, downstream of the gun air regulator, to shut off air to the gun.
- B. Connect the air hose (K) to the 1/4 npsm gun air inlet.
- C. Connect the other end of the air hose (K) to the outlet of the gun air regulator (L).

## 2. Connect the Fluid Hose

### NOTE:

- Before connecting the fluid line, blow it out with air and flush it with solvent. Use solvent which is compatible with the fluid to be sprayed.
  - If better control of fluid pressure is needed, install a fluid regulator (U) on the fluid line to level out fluid pressure to the gun. See Fig. 1.
  - Use of an inline fluid filter (N) is recommended to remove coarse particles and sediment, to avoid clogging the spray tip and causing finishing defects.
- A. Connect the fluid hose (H) to the gun fluid inlet. If desired, install a fluid swivel (W) at the gun inlet, for best maneuverability.
  - B. Connect the other end of the fluid hose (H) to the pump fluid outlet.

### **WARNING**



#### **INJECTION HAZARD**

To reduce the risk of property damage or serious injury, including fluid injection, which could be caused by component rupture or unrelieved fluid pressure,

- If a plugged tip occurs, shut off the air supply to the pump, lock the gun trigger safety, and **very slowly** loosen the air cap retaining ring to relieve pressure in the cavity between the ball/seat shutoff and the plugged tip. Clear the tip orifice or tip filter, if installed.
- A fluid pressure regulator (U) must be installed in the system if the pump's maximum working pressure exceeds the gun's maximum fluid working pressure of 4000 psi (28 MPa, 280 bar).

# Setup

## 3. Flush the Spray Gun.

Remove the air cap retaining ring (18), air cap (14), and spray tip (33).

Before putting any finishing fluid through the spray gun, flush the gun out with a solvent that is compatible with the fluid to be sprayed, using the lowest possible fluid pressure and a grounded metal container.

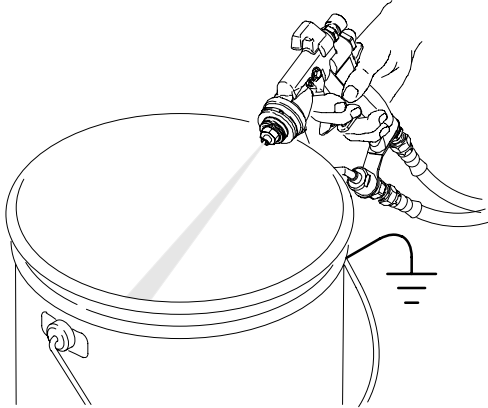

Fig. 2

9126A

## 4. Relieve the Pressure.

### **⚠ WARNING**

#### **PRESSURIZED EQUIPMENT HAZARD**

To reduce the risk of a serious injury whenever you are instructed to relieve pressure, follow the **Pressure Relief Procedure** on page 9.

## 5. Select a Spray Tip and Air Cap.

The fluid flow and pattern width depend on the size of the spray tip, the fluid viscosity, and the fluid pressure. Contact your Graco distributor for assistance in selecting an appropriate spray tip for your application. Refer to the **Tip Selection Charts** on page 26.

## 6. Install a Spray Tip.

Install a spray tip in the gun. Insert the tip into the air cap. Ensure that the tip locating pin is positioned in the slot of the air cap. Insert the air cap into the tip guard/retaining ring (18) and tighten this assembly onto the gun firmly by hand, to ensure a good seal between the tip gasket and the seat housing (13).

## 7. Position the Air Cap

The air cap and spray tip position determines the direction of the spray pattern.

Rotate the air cap (the spray tip rotates with it) as needed to achieve the desired spray pattern direction.

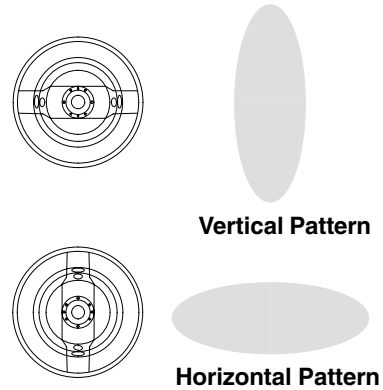

Fig. 3

02020



# Operation

## Safety

### ⚠ WARNING



#### INJECTION HAZARD

Remember, this is not an air spray gun. For your safety be sure to read and follow the Warnings on pages 2 and 3 and throughout the text of this instruction manual.

Keep the wallet sized warning card 179960, provided with the gun, with the operator of this equipment at all times. The card contains important treatment information should an injection injury occur. Additional cards are available at no charge from Graco.

## Pressure Relief Procedure

### ⚠ WARNING



#### INJECTION HAZARD

The system pressure must be manually relieved to prevent the system from starting or spraying accidentally. Fluid under high pressure can be injected through the skin and cause serious injury. To reduce the risk of an injury from injection, splashing fluid, or moving parts, follow the **Pressure Relief Procedure** whenever you:

- are instructed to relieve the pressure,
- stop spraying,
- check or service any of the system equipment,
- or install or clean the spray tip.

1. Shut off power to the pump by closing the bleed-type master air valve (required in the system).
2. Unlock the gun trigger safety. See Fig. 4.
3. Hold a metal part of the gun firmly to the side of a grounded metal waste container and trigger the gun to relieve the fluid pressure.
4. Lock the gun trigger safety. See Fig. 4.
5. If you suspect that the spray tip is completely clogged or that pressure has not been fully relieved after following the steps above, **very slowly** loosen the air cap retaining ring to relieve pressure in the cavity between the ball/seat shutoff and the plugged tip. Clear the tip orifice.

6. If you suspect that the fluid hose is completely clogged or that pressure has not been fully relieved after following the steps above, **very slowly** loosen the hose end coupling at the gun and relieve pressure gradually. Then loosen completely to clear the obstruction.

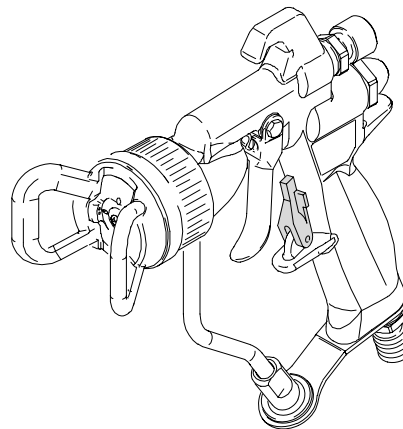

Gun Trigger Safety Unlocked

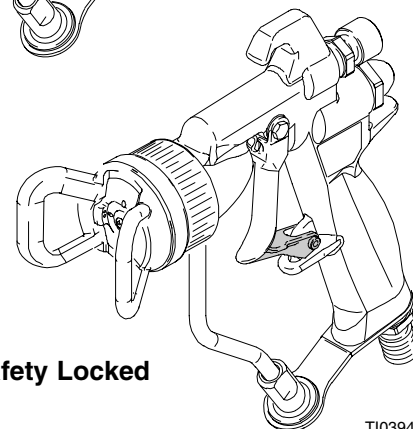

Gun Trigger Safety Locked

T10394

Fig. 4

## How the Air-Assisted Spray Gun Operates

The air-assisted spray gun combines airless and air spraying concepts. The spray tip shapes the fluid into a fan pattern, as does a conventional airless spray tip. Air from the air cap further atomizes the fluid and completes the atomization of the paint tails into the pattern to produce a more uniform pattern. The width of the pattern can be slightly adjusted by the pattern adjustment valve.

Note that the air-assisted spray gun differs from an air spray gun in that increasing the pattern air reduces the pattern width. To increase the pattern width, less pattern air or a larger size tip must be used.

The spray gun has a built-in lead and lag operation. When triggered, the gun begins emitting air before the fluid is discharged. When the trigger is released, the fluid stops before the air flow stops. This helps assure the spray is atomized and prevents fluid buildup on the air cap.

# Operation

## Adjust the Spray Pattern

### ⚠ WARNING



#### INJECTION HAZARD

To reduce the risk of component rupture and serious injury, including injection, do not exceed the gun's maximum fluid working pressure of 4000 psi (28 MPa, 280 bar) or the maximum working pressure of the lowest rated component in the system.

### ⚠ WARNING



#### COMPONENT RUPTURE HAZARD

Do not exceed the **maximum fluid and air pressure** of this gun. Higher pressures can cause parts to rupture and result in serious injury.

1. Do not turn on the air supply yet. Set the fluid pressure at a low starting pressure, approximately 600 psi (4.2 MPa, 42 bar). If a fluid pressure regulator is installed, use it to make the adjustments.

If your system does not have a fluid regulator, the fluid pressure is controlled by the air regulator supplying the pump, per the formula below:

$$\text{Pump Ratio} \times \text{Pump Air Regulator Setting} = \text{Fluid Pressure}$$

2. Trigger the gun to check the atomization; do not be concerned about the pattern shape yet.
3. Slowly increase the fluid pressure, just to the point where a further increase in fluid pressure does not significantly improve fluid atomization.
4. Close off the pattern adjustment air by turning the knob (S, see Fig. 5) clockwise (in) all the way. This sets the gun for its widest pattern.

5. Set the atomizing air pressure at about 5 psi (0.35 bar, 35 kPa) when triggered. Check the spray pattern, then slowly increase the air pressure until the tails are completely atomized and pulled into the spray pattern. See Fig. 6. Do not exceed 100 psi (0.7 MPa, 7 bar) air pressure to the gun.

*For a narrower pattern, turn the pattern adjustment valve knob (S, see Fig. 5) counterclockwise (out). If the pattern is still not narrow enough, increase the air pressure to the gun slightly or use a different size tip.*

**NOTE:** There is no fan adjustment when using AA RAC tips and caps.

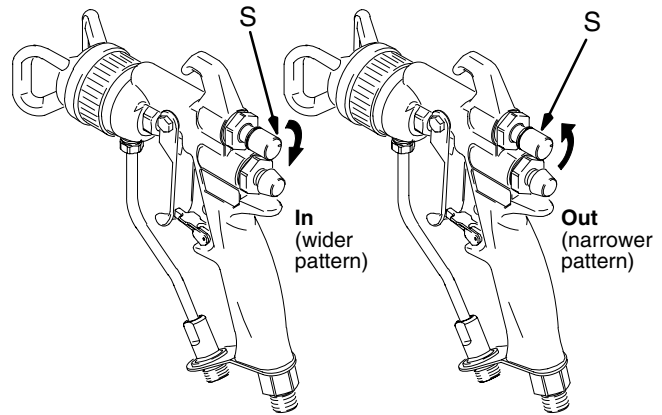

T10396

Fig. 5

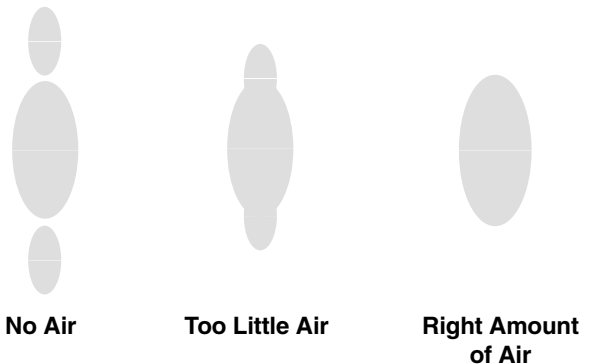

0792

Fig. 6

# Operation

## Air Pressure Verification Kit for HVLP Guns

**NOTE:** When using Gun Part No. 243575, with the 239898 Air Cap, the compliant air pressure should be verified by using Air Pressure Verification Kit 243581 (not to be used for actual spraying). Refer to page 30.

Install the verification kit air cap on the gun. Turn on the air to the gun, then trigger the gun to read the air pressure on the gauge. To be HVLP compliant, the air pressure must not exceed 10 psi (70 kPa, 0.7 bar).

Remove the verification kit air cap and install Air Cap 239898.

## Apply the Fluid

Always hold the gun at a right angle from the surface. Do not make an arc with the gun as it causes an uneven coat of fluid. See Fig. 7.

1. To achieve the best results when applying fluid, keep the gun perpendicular to the surface and maintain a consistent distance of approximately 8 to 12 inches (200 to 300 mm) from the object being sprayed. See Fig. 7.
2. To obtain an even finish, use smooth, even strokes across the object being sprayed with 50% overlap.
3. Paint using parallel strokes. This spray gun applies all coatings evenly without cross coating.

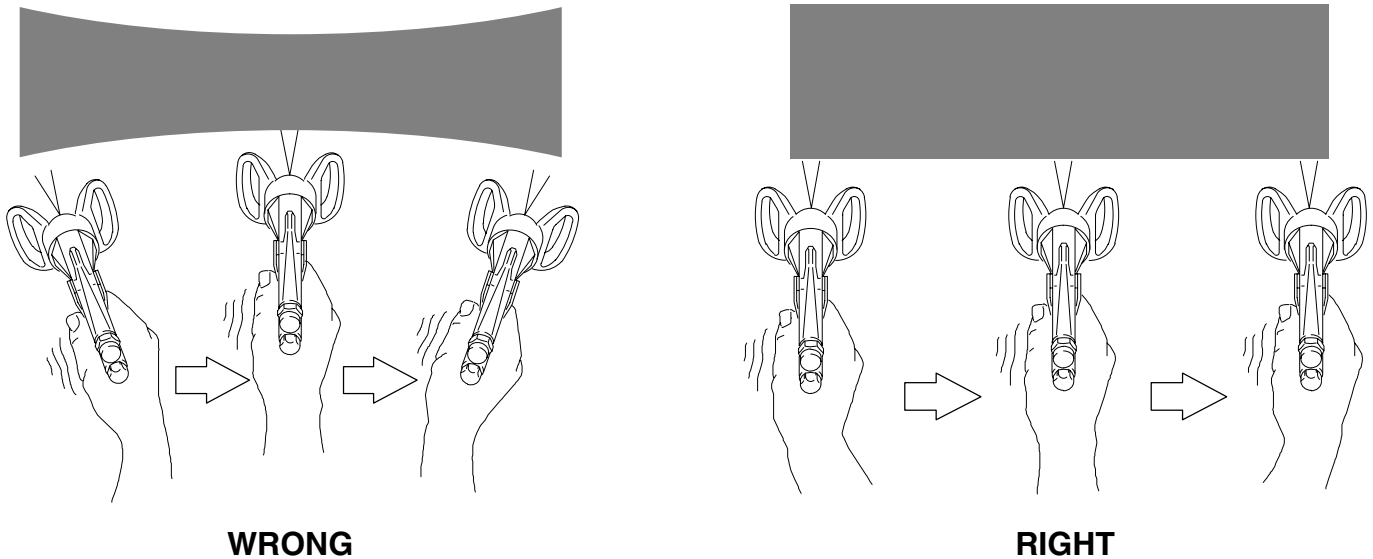

Fig. 7

T10392

# Daily Gun Care, Flushing, and Cleaning

## ⚠ WARNING

### PRESSURIZED EQUIPMENT HAZARD

To reduce the risk of a serious injury whenever you are instructed to relieve pressure, follow the **Pressure Relief Procedure** on page 9.

## ⚠ CAUTION

Clean all parts with a non-conductive solvent, compatible with the fluid being sprayed. Conductive solvents can cause the gun to malfunction.

Methylene chloride with formic or propionic acid is not recommended as a flushing or cleaning solvent with this gun as it will damage aluminum and nylon components.

## ⚠ CAUTION

Solvent left in gun air passages could result in a poor quality paint finish. Do not use any cleaning method which may allow solvent into the gun air passages.

**Do not point the gun up while cleaning it.**

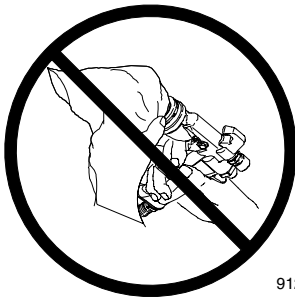

9122A

**Do not wipe the gun with a cloth soaked in solvent; ring out the excess.**



02027

**Do not immerse the gun in solvent.**

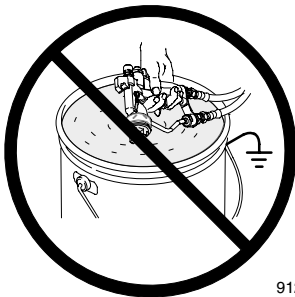

9127A

**Do not use metal tools to clean the air cap holes as this may scratch them; scratches can distort the spray pattern.**



02055

## General System Maintenance

1. Relieve the pressure.
2. Clean the fluid and air line filters daily.
3. Check for any fluid leakage from the gun and fluid hoses. Tighten fittings or replace equipment as needed.
4. Flush the gun before changing colors and whenever you are done operating the gun.

# Daily Gun Care, Flushing, and Cleaning

## **⚠ WARNING**

### **PRESSURIZED EQUIPMENT HAZARD**

To reduce the risk of a serious injury whenever you are instructed to relieve pressure, follow the **Pressure Relief Procedure** on page 9.

1. Relieve the pressure.
2. Remove the tip guard assembly (18), air cap (14), and spray tip (33).
3. Disconnect the fluid supply hose (H) and air supply hose (J) from the gun.

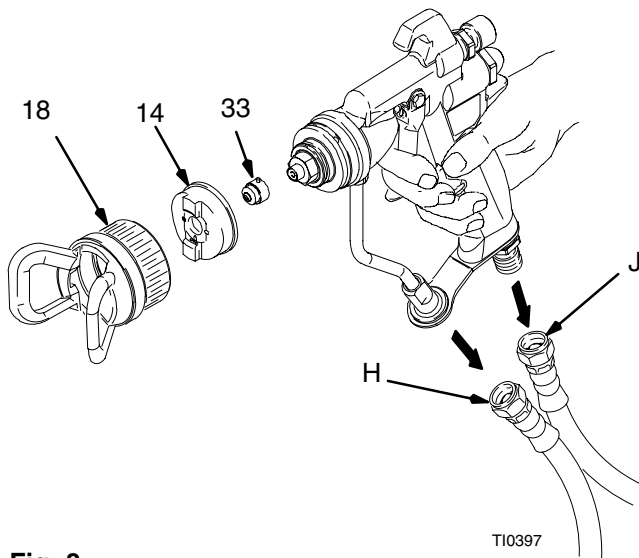

**Fig. 8**

4. Connect the solvent supply hose (T) to the gun.

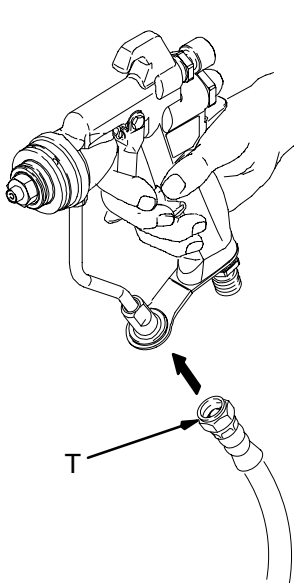

**Fig. 9**

5. Increase the pressure slowly. Point the gun down into a grounded metal container and flush the gun with solvent until all traces of fluid are removed from the gun passages.

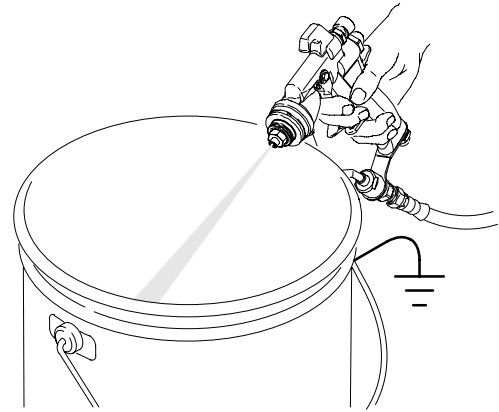

**Fig. 10**

6. Turn off the solvent supply.
7. Relieve the pressure.
8. Disconnect the solvent (T) supply hose from the gun.

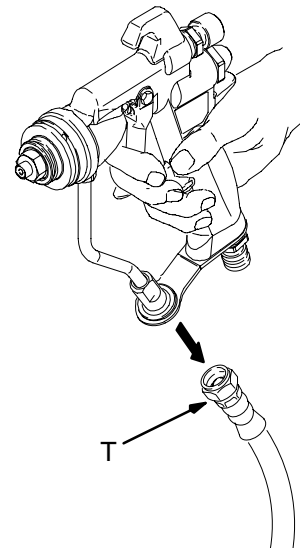

**Fig. 11**

# Daily Gun Care, Flushing, and Cleaning

## ⚠ CAUTION

Trigger the gun whenever you tighten or remove the seat housing. This keeps the needle ball away from the seating surface and prevents the seat from being damaged.

- If it is necessary to remove the seat housing (13) to clean, trigger the gun while you remove the seat housing with the gun tool (36). Remove the seat housing gasket (12b) and replace with a new gasket.

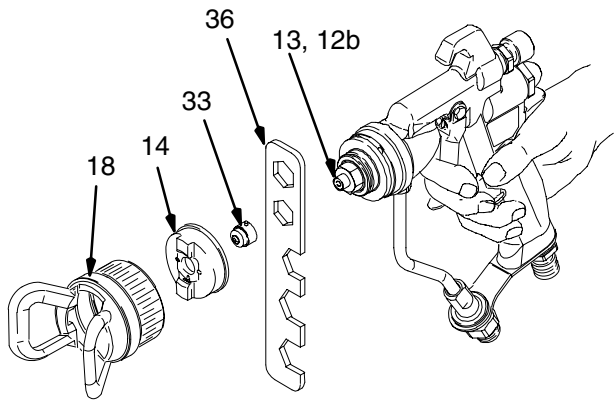

T10398

Fig. 12

- Clean the tip guard assembly (18), air cap (14), and seat housing (13) with solvent.
- Dip the end of a soft-bristle brush into a compatible solvent. Do not continuously soak the brush's bristles with solvent and do not use a wire brush.

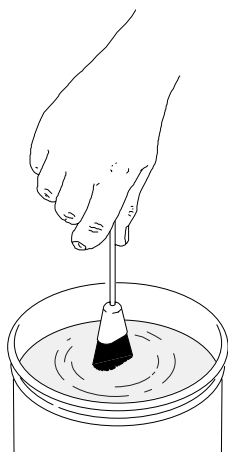

02007

Fig. 13

- With the gun pointed down, clean the front of the gun, using the soft-bristle brush and solvent.

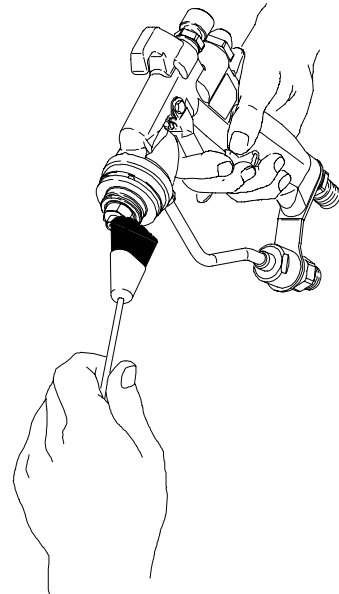
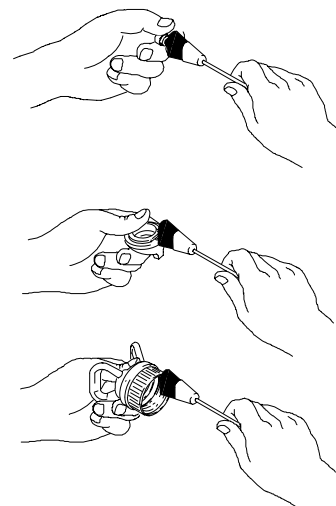

Fig. 14

- Scrub the tip guard assembly, air cap, and spray tip with the soft-bristle brush. To clean out air cap holes, use a soft implement, such as a toothpick, to avoid damaging critical surfaces. Clean the air cap and spray tip daily, minimum. Some applications require more frequent cleaning.



T10399

Fig. 15

# Daily Gun Care, Flushing, and Cleaning

14. Be sure to install a new seat gasket (12b). Trigger the gun while you install the seat housing (13) with the gun tool (36). Tighten the housing securely to obtain a good seal. Refer to Fig. 16 for recommended torque values. When properly tightened, the flange will bottom out on the gun.
15. Install the tip guard assembly (18), air cap (14), and spray tip (33).

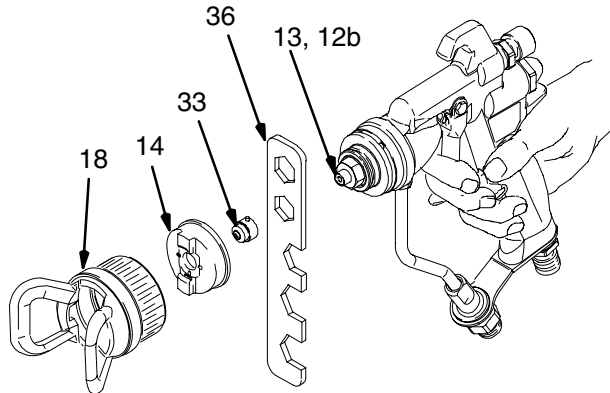

T10398

**Fig. 16**

16. Dampen a soft cloth with solvent and wring-out the excess. Point the gun down and wipe off the outside of the gun.



9122A

**Fig. 17**

17. After cleaning the gun, lubricate the following parts with lubricant 111265 weekly:

- Trigger pivot pin
- Boss on both sides of the gun where the trigger contacts the gun body
- Fluid needle shaft, behind trigger

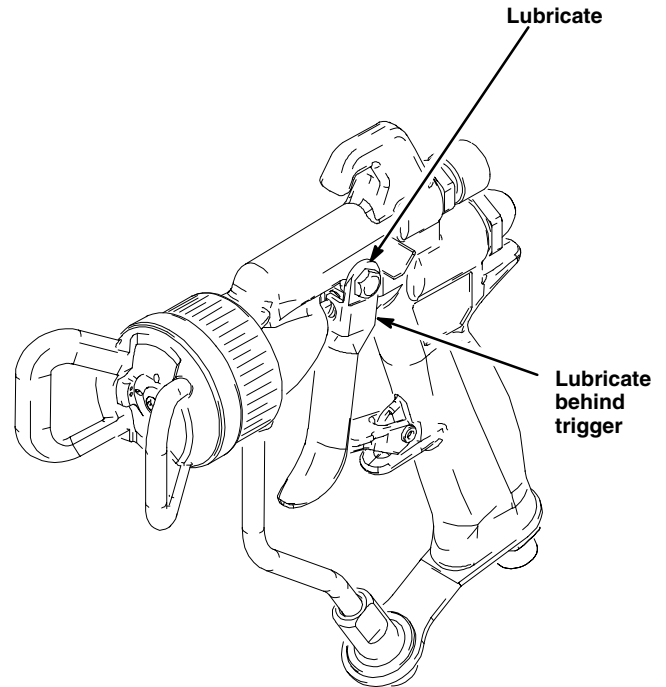

T10098

**Fig. 18**

# Troubleshooting

## ⚠ WARNING

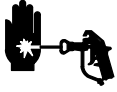

### INJECTION HAZARD

To reduce the risk of a fluid injection injury, follow the **Pressure Relief Procedure** on page 9 before checking or servicing any of the system equipment and whenever you are instructed to relieve pressure.

### NOTE:

- Check all possible remedies in the troubleshooting charts before disassembling the gun.
- Some improper patterns are caused by the improper balance between air and fluid.

## General Troubleshooting

Problem	Cause	Solution
Fluid leakage from back of fluid packing area	Worn packings or needle shaft	Replace entire needle assembly (12).
Air leakage from front of gun	Air valve not seating properly	Clean or replace air valve (23).
Fluid leakage from front of gun	Needle ball worn or damaged Worn seat assembly	Replace entire needle assembly (12). Replace the seat assembly (13) and gasket (12b). The gasket must be replaced whenever the seat assembly is removed.
Fluid in air passages	Spray tip seal leaking  Leaking around seat housing  Fluid inlet fitting leaking	Tighten tip guard assembly (18) or replace spray tip (33).  Replace the gasket (12b). The gasket must be replaced whenever the seat assembly is removed.  Replace the fluid tube gasket (7). The gasket must be replaced whenever the fluid tube connector is removed.
Slow fluid shut-off	Fluid buildup on fluid needle components	Remove and clean or replace the fluid needle assembly (12).
No fluid output when triggered	Tip orifice plugged  Fluid hose plugged	<b>Very slowly</b> loosen tip guard assembly (18), air cap (14), and spray tip (33). Clean the tip orifice.  After tip removal (see above), <b>very slowly</b> loosen the hose end coupling at the gun and relieve pressure gradually. Then loosen completely to clear the obstruction.



# Troubleshooting

**⚠ WARNING**



**INJECTION HAZARD**  
 To reduce the risk of a fluid injection injury, follow the **Pressure Relief Procedure** on page 9 before checking or servicing any of the system equipment and whenever you are instructed to relieve pressure.



**NOTE:**

- Check all possible remedies in the troubleshooting charts before disassembling the gun.
- Some improper patterns are caused by the improper balance between air and fluid.

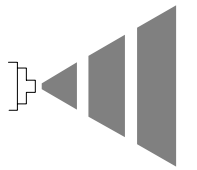
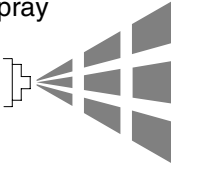
## Spray Pattern Troubleshooting

Problem	Cause	Solution
Fluttering or spitting spray  9240A	Insufficient fluid supply  Air in paint supply line  Attempting to “feather” (partially trigger) the gun	Adjust fluid regulator or fill fluid supply tank.  Check, tighten pump siphon hose connections, bleed air from paint line.  Cannot “feather” with an AA gun. Feathering will cause drastic reduction of pressure at the tip, resulting in poor atomization and/or spitting.
Striping spray  9240A	Spray tip orifice partially plugged	Clean or replace spray tip. See page 13.
Irregular pattern  9240A	Fluid build-up on spray tip, or spray tip partially plugged  On defective side of pattern, air horn holes are partially or totally plugged	Clean spray tip. See page 13.  Clean air horn holes with solvent and soft brush. See page 13.
Pattern pushed to one side, same side of air cap gets dirty	Air horn holes partially or totally plugged	Clean air horn holes with solvent and soft brush or toothpick. See page 13.

# Service

## Items Needed for Service

- Gun Tool – provided
- Packing Installation Tool – provided
- Needle Wrench – provided
- Adjustable Wrench
- Pliers
- O-ring Pick
- Lubricant part no. 111265; see **Accessories** to order
- Compatible Solvent

## Repair Kit 241619

**NOTE:** Order Repair Kit 241619. For the best results, use all the new parts in the kit. Kit parts are marked with an asterisk, for example (7\*). Refer to pages 22 and 24.

## Fan Valve Repair

### ⚠ WARNING



#### INJECTION HAZARD

To reduce the risk of a fluid injection injury, follow the **Pressure Relief Procedure** on page 9 before checking or servicing any of the system equipment and whenever you are instructed to relieve pressure.

1. Relieve the pressure.
2. Unscrew the fan valve packing nut (A) from the back of the gun body (1). Slide the fan valve assembly (28) out of the gun body. See Fig. 19.

3. Remove the retaining ring (28b) from the fan valve shaft (B). Carefully remove the two u-cups (28a) from the packing nut (A). Be careful not to damage the packing groove sealing surfaces.
4. Install the u-cups (28a\*) in the packing nut (A) with the lips of the u-cups facing out of the packing nut, toward the gun body (1).
5. Reinstall the fan valve assembly (28) into the gun body (1). Screw the packing nut (A) into the gun body. Torque to 125–135 in-lb (14–15 N•m).



Lips face out of nut, toward gun body (1).



Torque to 125–135 in-lb (14–15 N•m).

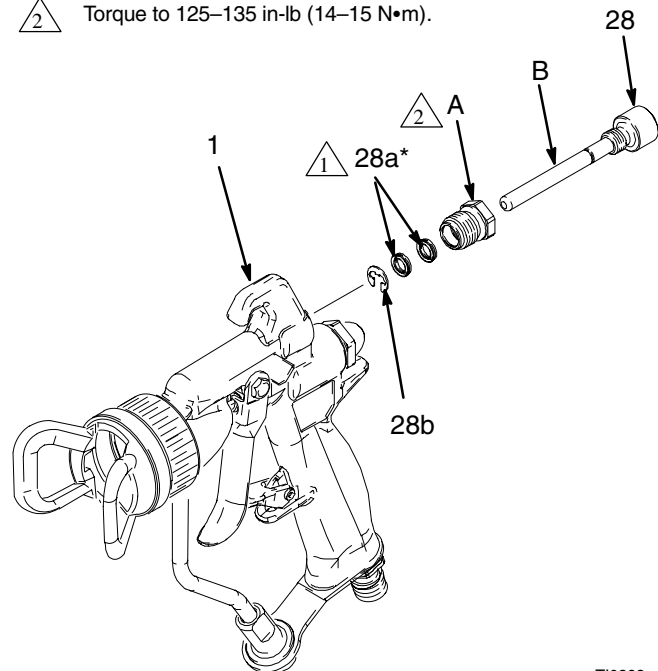

T10393

Fig. 19

# Service

## Complete Gun Packing Replacement

### Disassembly

#### NOTE:

- Gun Repair Kit 241619 is available. The kit includes an o-ring (17), gaskets (7, 12b), u-cups (18a, 22, 28a), air valve assembly (23), and seal installation tool (34).
- Clean parts with a solvent that is compatible with the parts and the fluid being sprayed.
- Lightly lubricate the parts indicated in Fig. 23 with lubricant 111265.

## ⚠ WARNING



### INJECTION HAZARD

To reduce the risk of a fluid injection injury, follow the **Pressure Relief Procedure** on page 9 before checking or servicing any of the system equipment and whenever you are instructed to relieve pressure.

1. Relieve the pressure. Remove the fluid and air hoses from the gun.
2. Remove the tip guard assembly (18), air cap (14), and spray tip (33). See Fig. 23.
3. Unscrew the air separator (16) from the front of the gun body (1). Carefully remove the o-ring (17). Do not damage the o-ring groove.
4. Trigger the gun to pull the needle ball off the seat while you unscrew the seat assembly (13) from the gun body (1), using the gun tool (36). Remove and discard the seat assembly gasket (12b).

**NOTE:** Always install a new seat gasket (12b) whenever you remove the seat assembly (13).

5. Remove the trigger lock screw (20), pivot pin (21), and trigger (19).
6. Unscrew the spring cap (27) from the back of the gun body (1). Remove the two springs (25, 26).

7. Use the needle wrench (41) on the flats of the needle to prevent it from rotating while unscrewing the needle extension (24) from the fluid needle. See Fig. 20.

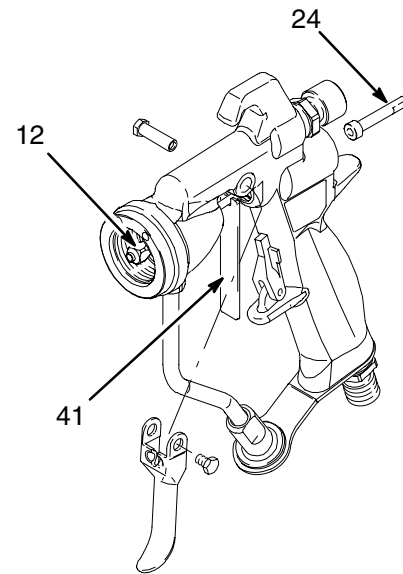

T10390

**Fig. 20**

8. Pull the air valve assembly (23) out the back of the gun.
9. Grip the ball housing with a pliers and pull the fluid needle assembly (12) out the front of the gun. If the needle is bent or damaged, or the packing is worn or leaking, replace the entire needle assembly.
10. Remove the o-rings (12a) from the packing cartridge on the needle shaft. Clean the o-ring groove and the needle.
11. Using a pick, remove the u-cup (22) from the gun body.
12. Unscrew the fluid inlet fitting (11). Remove and clean or replace the inline fluid filter (10).
13. Unscrew the fluid tube connector (C) from the gun's fluid inlet. Carefully remove the gasket (7). Do not damage the seat.

# Service

## Reassembly

1. Install the gasket (7\*) in the gun. Screw the fluid tube connector (C) into the gun's fluid inlet. Torque to 105–115 in-lb (12–13 N•m). See Fig. 23.
2. Place the new u-cup (22\*) on the seal installation tool (34\*), with the u-cup lips facing the tool as shown in Fig. 21. Push the u-cup into the back of the gun until a definite snap is felt.

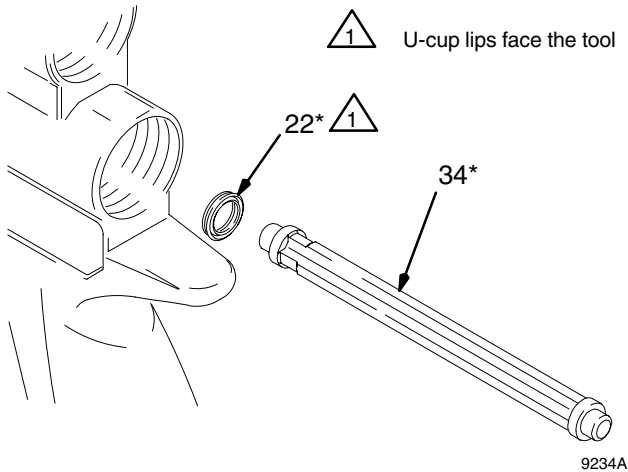

Fig. 21

3. Install the two o-rings (12a) on the packing cartridge on the needle shaft. Lightly lubricate the o-rings. Also lubricate the needle shaft where the packing slides.
4. Insert the fluid needle assembly (12) into the front of the gun. Use the tool (12c) to push the packing cartridge into the gun body until the cartridge bottoms out. See Fig. 22.

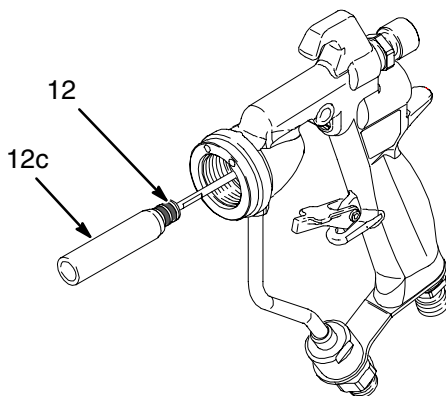

Fig. 22

5. Lubricate the front end of the air valve assembly. Slide the air valve assembly (23\*) onto the back of the fluid needle assembly (12) and push the air valve assembly into the back of the gun as far as it will go.
6. Use the needle wrench (41) on the flats of the needle to prevent it from rotating while screwing the needle extension (24) onto the fluid needle. See Fig. 20. **Use only finger pressure on the tool to tighten. Do not overtighten!**
7. Install the two springs (25, 26). Screw the spring cap (27) into the back of the gun body (1). Torque to 125–135 in-lb (14–15 N•m).
8. Install the trigger (19), pivot pin (21), and trigger lock screw (20). Torque to 20–30 in-lb (2.3–3.3 N•m). Lubricate both sides of the pivot pin where the trigger contacts the pin, and lubricate the boss on both sides of the gun where the trigger contacts the gun body.

**NOTE:** Always install a new seat gasket (12b) whenever you replace the seat assembly (13).

9. Install a new seat gasket (12b). Trigger the gun to pull the needle back while you screw the seat assembly (13) into the gun body (1), using the gun tool (36). Refer to Fig. 23 for recommended torque values. When properly tightened, the flange will bottom out on the gun.
10. Install the o-ring (17\*) and screw the air separator (16) onto the front of the gun body (1).
11. Install the spray tip (33) and air cap (14), then secure with the tip guard assembly (18).

# Service

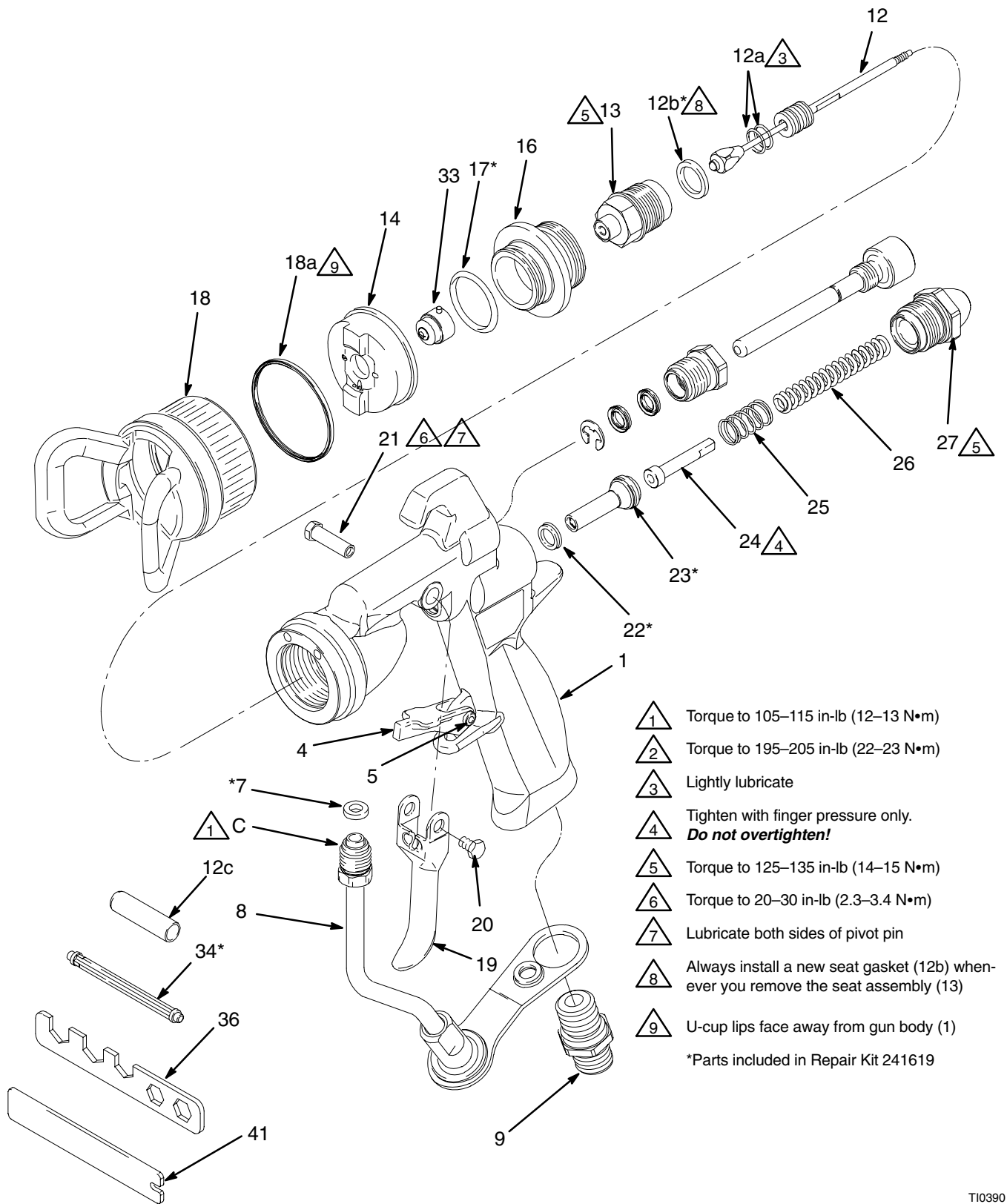

Fig. 23

T10390

# Parts

## Part No. 243573 Air-Assisted Spray Gun

## Part No. 243574 Hi-Flow Air-Assisted Spray Gun

## Part No. 243575 HVLP Air-Assisted Spray Gun with Compliant Air Cap

Ref. No.	Part No.	Description	Qty.	Ref. No.	Part No.	Description	Qty.
1	243578	BODY, gun	1	18a*	192760	•U-CUP	1
4	194745	LOCK, trigger	1	19	192271	TRIGGER	1
5	112033	PIN, dowel	1	20	203953	SCREW, trigger lock	1
7*	115133	GASKET, tube; acetal	1	21	192272	PIN, pivot	1
8	243572	TUBE, fluid	1	22*	188493	U-CUP; UHMWPE	1
9	195065	FITTING, air inlet; 1/4–18.6 special form spt(m)	1	23*	241503	AIR VALVE ASSEMBLY	1
12	243585	KIT, needle; 3/32 in. carbide includes items 12a through 12c; used on Part Nos. 243573 and 243575	1	24	194563	EXTENSION, needle	1
	243586	KIT, needle; 1/8 in. carbide includes items 12a through 12c; used on Part No. 243574	1	25	114069	SPRING, air valve	1
12a	111450	•O-RING	2	26	115141	SPRING, needle	1
12b*	115134	•GASKET, seat; acetal	1	27	194562	CAP, spring	1
12c	196140	•TOOL, repair, packing	1	28	241484	FAN VALVE ASSEMBLY includes replaceable items 28a and 28b	1
13	243563	SEAT ASSEMBLY; 3/32 in. carbide; used on Part Nos. 243573 and 243575	1	28a*	188493	•U-CUP; UHMWPE	2
	243564	SEAT ASSEMBLY; 1/8 in. carbide; used on Part No. 243574	1	28b	115114	•RING, retaining	1
14	239781	AIR CAP; used on Part Nos. 243573 and 243574	1	33	GG4XXX	SPRAY TIP, customer's choice, see page 26	1
	239898	AIR CAP, compliant; used on Part No. 243575 only	1	34*	192282	TOOL, seal installation	1
16	194749	SEPARATOR, air	1	36	194750	TOOL, gun	1
17*	107079	O-RING; PTFE®	1	39▲	172479	TAG, instruction (not shown)	1
18	243568	TIP GUARD; includes replaceable item 18a	1	40▲	222385	WARNING CARD (not shown)	1
				41	196319	WRENCH, needle	1

▲ Replacement Warning labels, tags and cards are available at no cost.

\* These parts are included in Repair Kit 241619, which may be purchased separately.

# Parts

Part No. 243573 Air-Assisted Spray Gun

Part No. 243574 Hi-Flow Air-Assisted Spray Gun

Part No. 243575 HVLP Air-Assisted Spray Gun with Compliant Air Cap

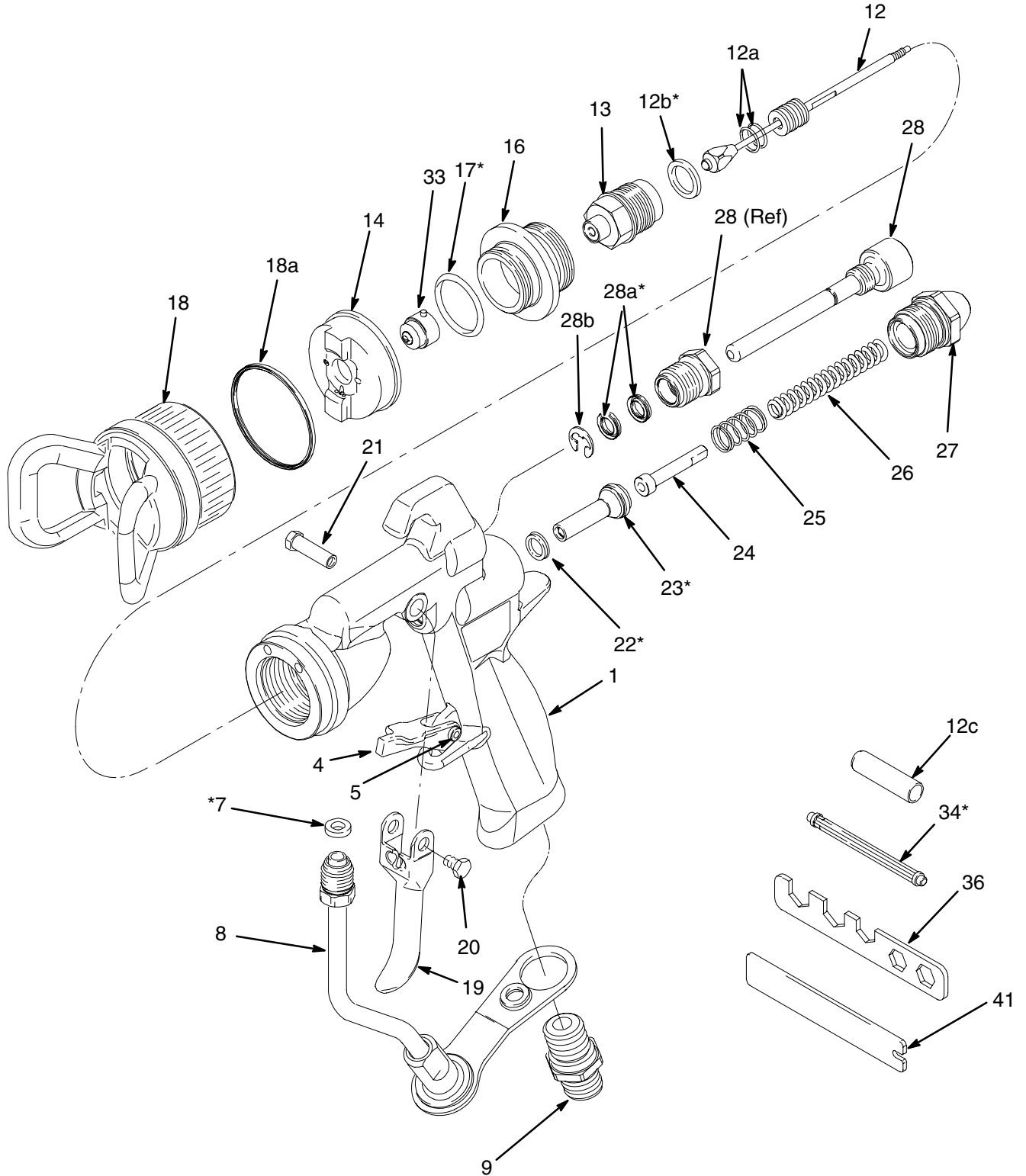

T10390

# Parts

## Part No. 243576 AA RAC Spray Gun

## Part No. 243577 Hi-Flow AA RAC Spray Gun

Ref. No.	Part No.	Description	Qty.	Ref. No.	Part No.	Description	Qty.
1	243578	BODY, gun	1	19	192271	TRIGGER	1
4	194745	LOCK, trigger	1	20	203953	SCREW, trigger lock	1
5	112033	PIN, dowel	1	21	192272	PIN, pivot	1
7*	115133	GASKET, tube; acetal	1	22*	188493	U-CUP; UHMWPE	1
8	243572	TUBE, fluid	1	23*	241503	AIR VALVE ASSEMBLY	1
9	195065	FITTING, air inlet; 1/4–18.6 special form spt(m)	1	24	194563	EXTENSION, needle	1
11	192096	HOUSING, AA RAC	1	25	114069	SPRING, air valve	1
12	243585	KIT, needle; 3/32 in. carbide includes items 12a through 12c; used on Part No. 243576	1	26	115141	SPRING, needle	1
	243586	KIT, needle; 1/8 in. carbide includes items 12a through 12c; used on Part No. 243577	1	27	194562	CAP, spring	1
12a	111450	•O-RING	2	28	196655	PLUG	1
12b*	115134	•GASKET, seat; acetal	1	33	242XXX	AA RAC SPRAY TIP, customer's choice; see chart on page 28; includes item 33a	1
12c	196140	•TOOL, repair, packing	1	33a	193000	•SEAT, fluid	1
13	243565	SEAT ASSEMBLY, AA RAC; 3/32 in. carbide; used on Part No. 243576	1	34*	192282	TOOL, seal installation	1
	243566	SEAT ASSEMBLY, AA RAC; 1/8 in. carbide; used on Part No. 243577	1	36	194750	TOOL, gun	1
18	243570	AA RAC TIP GUARD	1	39▲	172479	TAG, instruction (not shown)	1
				40▲	222385	WARNING CARD (not shown)	1
				41	196319	WRENCH, needle	1

▲ Replacement Warning labels, tags and cards are available at no cost.

\* These parts are included in Repair Kit 241619, which may be purchased separately.





# Spray Tip Selection Charts

**NOTE:** Part No. 243586 Fluid Needle and 243564 Diffuser-seat must be used with GG4 tips larger than 0.025 in. (0.635 mm).

## Standard Spray Tips, for use with Air Cap 239781

Orifice Size inches (mm)	Fan Width at 12" (300 mm) Inches (mm)	*Light to Medium Viscosity fl oz/min (liters/min)	*Heavy Viscosity fl oz/min (liters/min)	Part No.
0.007 (0.178)	2-4 (50-100)	4.0 (0.1)		GG4107
	4-6 (100-150)			GG4207
	6-8 (150-200)			GG4307
0.009 (0.229)	2-4 (50-100)	7.0 (0.2)		GG4109
	4-6 (100-150)			GG4209
	6-8 (150-200)			GG4309
	8-10 (200-250)			GG4409
0.011 (0.279)	2-4 (50-100)	10.0 (0.3)		GG4111
	4-6 (100-150)			GG4211
	6-8 (150-200)			GG4311
0.013 (0.330)	4-6 (100-150)	13.0 (0.4)		GG4213
	6-8 (150-200)			GG4313
	8-10 (200-250)			GG4413
	10-12 (250-300)			GG4513
0.015 (0.381)	4-6 (100-150)	17.0 (0.5)		GG4215
	6-8 (150-200)			GG4315
	8-10 (200-250)			GG4415
0.017 (0.432)	10-12 (250-300)	22.0 (0.7)	17.0 (0.5)	GG4515
	12-14 (300-350)			GG4615
	14-16 (350-400)			GG4715
	16-18 (400-460)			GG4815
0.019 (0.483)	4-6 (100-150)	28.0 (0.8)	21.0 (0.6)	GG4217
	6-8 (150-200)			GG4317
	8-10 (200-250)			GG4417
	10-12 (250-300)			GG4517
	12-14 (300-350)			GG4617
	14-16 (350-400)			GG4717
	16-18 (400-460)			GG4817
18-20 (457-508)	GG4917			
0.019 (0.483)	4-6 (100-150)	28.0 (0.8)	21.0 (0.6)	GG4219
	6-8 (150-200)			GG4319
	8-10 (200-250)			GG4419
	10-12 (250-300)			GG4519
	12-14 (300-350)			GG4619
	14-16 (350-400)			GG4719
	16-18 (400-460)			GG4819
18-20 (457-508)	GG4919			

Orifice Size inches (mm)	Fan Width at 12" (300 mm) Inches (mm)	*Light to Medium Viscosity fl oz/min (liters/min)	*Heavy Viscosity fl oz/min (liters/min)	Part No.
0.007 (0.178)	2-4 (50-100)	4.0 (0.1)		GG4107
	4-6 (100-150)			GG4207
	6-8 (150-200)			GG4307
0.009 (0.229)	2-4 (50-100)	7.0 (0.2)		GG4109
	4-6 (100-150)			GG4209
	6-8 (150-200)			GG4309
	8-10 (200-250)			GG4409
0.011 (0.279)	2-4 (50-100)	10.0 (0.3)		GG4111
	4-6 (100-150)			GG4211
	6-8 (150-200)			GG4311
0.013 (0.330)	4-6 (100-150)	13.0 (0.4)		GG4213
	6-8 (150-200)			GG4313
	8-10 (200-250)			GG4413
	10-12 (250-300)			GG4513
0.015 (0.381)	4-6 (100-150)	17.0 (0.5)		GG4215
	6-8 (150-200)			GG4315
	8-10 (200-250)			GG4415
0.017 (0.432)	10-12 (250-300)	22.0 (0.7)	17.0 (0.5)	GG4515
	12-14 (300-350)			GG4615
	14-16 (350-400)			GG4715
	16-18 (400-460)			GG4815
0.019 (0.483)	4-6 (100-150)	28.0 (0.8)	21.0 (0.6)	GG4217
	6-8 (150-200)			GG4317
	8-10 (200-250)			GG4417
	10-12 (250-300)			GG4517
	12-14 (300-350)			GG4617
	14-16 (350-400)			GG4717
	16-18 (400-460)			GG4817
18-20 (457-508)	GG4917			
0.019 (0.483)	4-6 (100-150)	28.0 (0.8)	21.0 (0.6)	GG4219
	6-8 (150-200)			GG4319
	8-10 (200-250)			GG4419
	10-12 (250-300)			GG4519
	12-14 (300-350)			GG4619
	14-16 (350-400)			GG4719
	16-18 (400-460)			GG4819
18-20 (457-508)	GG4919			

# Spray Tip Selection Charts

## Standard Spray Tips, for use with Air Cap 239781

Orifice Size	Fan Width at 12" (300 mm)	*Light to Medium Viscosity	*Heavy Viscosity	Part No.
0.021 (0.533)	6-8 (150-200)	35.0 (1.0)	27.0 (0.8)	GG4321
	8-10 (200-250)			GG4421
	10-12 (250-300)			GG4521
	12-14 (300-350)			GG4621
	14-16 (350-400)			GG4721
	18-20 (457-508)			GG4921
0.023 (0.584)	8-10 (200-250)	40.0 (1.2)	34.0 (0.97)	GG4423
	10-12 (250-300)			GG4523
	12-14 (300-350)			GG4623
	14-16 (350-400)			GG4723
	18-20 (457-508)			GG4923
0.025 (0.635)	8-10 (200-250)	50.0 (1.5)	42.0 (1.2)	GG4425
	12-14 (300-350)			GG4625
	14-16 (350-400)			GG4725
	16-18 (400-460)			GG4825
	18-20 (460-510)			GG4925
0.027 (0.686)	10-12 (250-300)	58.5 (1.7)	50.0 (1.4)	GG4527
	12-14 (300-350)			GG4627
	16-18 (400-460)			GG4827

Orifice Size	Fan Width at 12" (300 mm)	*Light to Medium Viscosity	*Heavy Viscosity	Part No.
0.029 (0.737)	12-14 (300-350)	68.0 (1.9)	59.0 (1.7)	GG4629
0.031 (0.787)	8-10 (200-250)	78.0 (2.2)	69.0 (2.0)	GG4431
	12-14 (300-350)			GG4631
0.033 (0.838)	12-14 (300-350)	88.0 (2.5)	79.0 (2.3)	GG4633
	16-18 (400-460)			GG4833
0.035 (0.889)	8-10 (200-250)	98.0 (2.8)	89.0 (2.5)	GG4435
	12-14 (300-350)			GG4635
0.037 (0.940)	14-16 (350-400)	108.0 (3.1)	99.0 (2.8)	GG4737
0.039 (0.991)	10-12 (250-300)	118.0 (3.4)	109.0 (3.1)	GG4539
	12-14 (300-350)			GG4639
	16-18 (400-460)			GG4839

\*Fluid output at 600 psi (4.1 MPa, 41 bar).

Fluid output (Q) at other pressures (P) can be calculated by this formula:  $Q = (0.041) (QT) \sqrt{P}$ .

Where QT = Fluid output (fl oz/min) from the above table for the selected orifice size.

# Spray Tip Selection Charts

## Standard Sealer Tips, for use with Air Cap 239781

**NOTE:** Part No. 243586 Fluid Needle and 243564 Diffuser-seat must be used with GG4 tips larger than 0.025 in. (0.635 mm).

Orifice Size inches (mm)	*Light to Medium Viscosity fl oz/min (liters/min)	*Heavy Viscosity fl oz/min (liters/min)	Part No.
0.025 (0.635)	50.0 (1.5)	42.0 (1.2)	<b>GG4025</b>
0.029 (0.737)	50.0 (1.5)	42.0 (1.2)	<b>GG4029</b>
0.031 (0.787)	50.0 (1.5)	42.0 (1.2)	<b>GG4031</b>
0.035 (0.889)	50.0 (1.5)	42.0 (1.2)	<b>GG4035</b>

\*Fluid output at 600 psi (4.1 MPa, 41 bar).

## AA Reverse-A-Clean (AA RAC™) Spray Tips

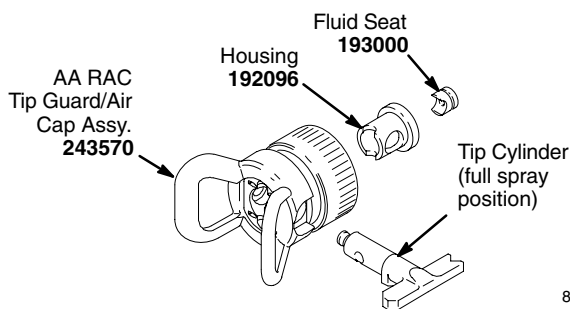

8027A

**NOTE:**

- AA RAC Tips 242XXX feature a 1-piece plastic fluid seat 193000. Do not use in combination with parts from previous generations of AA RAC Tips (AARXXX).
- The air separator (item 16) must be removed when using the AA RAC.
- AA RAC Conversion Kit is available. See page 30.

## AA Reverse-A-Clean (AA RAC™) Spray Tips

Orifice Size inches (mm)	Fan Width at 12" (300 mm) Inches (mm)	*Light to Medium Viscosity fl oz/min (liters/min)	*Heavy Viscosity fl oz/min (liters/min)	Part No.
0.011 (0.279)	6-8 (150-200)	10.0 (0.3)		<b>242311</b>
	8-10 (200-250)			<b>242411</b>
	10-12 (250-300)			<b>242511</b>
0.013 (0.330)	4-6 (100-150)	13.0 (0.4)		<b>242213</b>
	6-8 (150-200)			<b>242313</b>
	8-10 (200-250)			<b>242413</b>
	10-6-8 (150-200)			<b>242513</b>
	12-14 (300-350)			<b>242613</b>
0.015 (0.381)	4-6 (100-150)	17.0 (0.5)		<b>242215</b>
	6-8 (150-200)			<b>242315</b>
	8-10 (200-250)			<b>242415</b>
	10-12 (250-300)			<b>242515</b>
	12-14 (300-350)			<b>242615</b>
0.017 (0.432)	4-6 (100-150)	22.0 (0.7)	17.0 (0.5)	<b>242217</b>
	6-8 (150-200)			<b>242317</b>
	8-10 (200-250)			<b>242417</b>
	10-12 (250-300)			<b>242517</b>
	12-14 (300-350)			<b>242617</b>
0.019 (0.483)	4-6 (100-150)	28.0 (0.8)	21.0 (0.6)	<b>242219</b>
	6-8 (150-200)			<b>242319</b>
	8-10 (200-250)			<b>242419</b>
	10-12 (250-300)			<b>242519</b>
	12-14 (300-350)			<b>242619</b>

Continued on the next page.

# Spray Tip Selection Charts

## AA Reverse-A-Clean (AA RAC™) Spray Tips

Orifice Size	Fan Width at 12" (300 mm)	*Light to Medium Viscosity	*Heavy Viscosity	Part No.
0.021 (0.533)	4-6 (100-150)	35.0 (1.0)	27.0 (0.8)	242221
	6-8 (150-200)			242321
	8-10 (200-250)			242421
	10-12 (250-300)			242521
	12-14 (300-350)			242621
0.023 (0.584)	8-10 (200-250)	40.0 (1.2)	34.0 (0.97)	242423
	12-14 (300-350)			242623

Orifice Size	Fan Width at 12" (300 mm)	*Light to Medium Viscosity	*Heavy Viscosity	Part No.
0.025 (0.635)	10-12 (250-300)	50.0 (1.5)	42.0 (1.2)	242525
	12-14 (300-350)			242625
0.027 (0.686)	8-10 (200-250)	58.5 (1.7)	50.0 (1.4)	242427
0.029 (0.737)	10-12 (250-300)	68.0 (1.9)	59.0 (1.7)	242529
0.031 (0.787)	10-12 (250-300)	78.0 (2.2)	69.0 (2.0)	242531
	12-14 (300-350)			242631

\*Fluid output at 600 psi (4.1 MPa, 41 bar).

# Accessories

Use Only Genuine Graco Parts and Accessories

## Grounding Clamp and Wire 222011

12 ga, 25 ft (7.6 m) wire

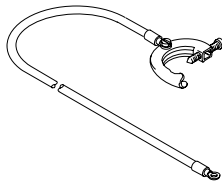

## High Pressure Ball Valves, Viton® Seals

5000 psi (35 MPa, 350 bar) Maximum Working Pressure  
Can be used as fluid drain valve.

- 210657 1/2 npt(m)
- 210658 3/8 npt(m)
- 210659 3/8 x 1/4 npt(m)

## In-line Fluid Filter 210500

5000 psi (35 MPa, 350 bar) Maximum Working Pressure  
100 mesh. Fits onto the gun's fluid connector. 1/4–18 npsm. Includes the parts shown below.

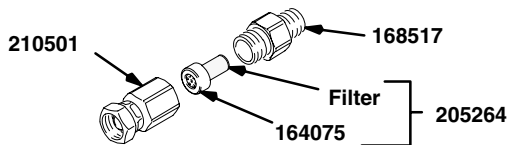

## Ruby Ball Needle Kit 243588

4000 psi (28 MPa, 280 bar) Maximum Working Pressure  
Includes: Ruby Ball Tipped Needle Assembly and gasket.

For use with acid catalyzed finishes. Use with diffuser-seat 243564 only. Not recommended for use with AA RAC tips.

## Bleed-type Master Air Valve

300 psi (2.1 MPa, 21 bar) Maximum Working Pressure  
Relieves air trapped in the air line between the pump air inlet and this valve when closed.

- 107141 3/4 npt(m x f) inlet & outlet
- 107142 1/2 npt(m x f) inlet & outlet

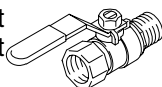

## Air Line Quick-disconnect 113367

Consists of:

- 113410 Coupling, female, quick-disconnect
- 113368 Coupling, male, quick-disconnect

## Brush 101892

For cleaning the gun.

## Fluid Swivel Connector 189018

5800 psi (40 MPa, 400 bar) Maximum Working Pressure  
To ease movement of the gun and fluid hose. 1/4–18 npsm.

## Air Whip Hoses

100 psi (0.7 MPa, 7 bar) Maximum Working Pressure  
To ease movement of the gun and hose. 1/4–18 npsm, polyurethane with SST braid.

- 238759 3 ft. (0.92 m) hose
- 236873 6 ft. (1.83 m) hose

## HVLP Verification Kit 243581

For air cap 239898 only, to determine air pressure behind the air cap. Do not use for actual spraying. To be compliant, atomizing air pressure must not exceed 10 psi (70 kPa, 0.7 bar).

## Conversion Kit 243790

Converts gun part no. 243573 with standard spray tip, tip guard, and air cap to gun part no. 243576 with the AA RAC assembly. See parts list and drawing below for parts included with kit.

Ref. No.	Part No.	Description	Qty.
1	243570	AA RAC AIR CAP ASSEMBLY	1
2	192096	AA RAC HOUSING	1
3	242XXX	TIP CYLINDER; tip of choice Includes item 3a	1
3a	193000	• FLUID SEAT	1
4	243565	DIFFUSER-SEAT	1
5	115134	GASKET, fluid	1

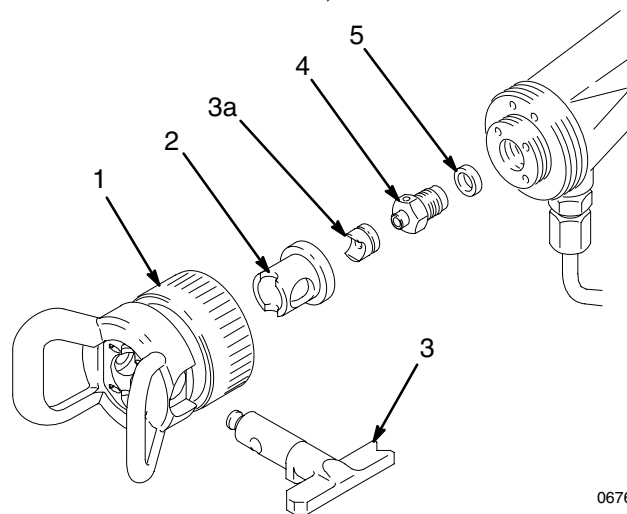

06765B

# Technical Data

Category	Data
Maximum Working Fluid Pressure	4000 psi (28 MPa, 280 bar)
Maximum Working Air Pressure	100 psi (0.7 MPa, 7 bar)
Maximum Compliant Inbound Air Pressure (Model 243575 only)	16 psi (110 kPa, 1.1 bar)
Maximum Working Fluid Temperature	120° F (49° C)
Fluid Inlet	1/4–18 npsm
Air Inlet	1/4–18 npsm (R1/4–19) compound male thread
Gun Weight	20.1 oz (570 grams)
*Sound Pressure at 30 psi (210 kPa, 2.1 bar)	86.2 dB(A)
*Sound Pressure at 100 psi (0.7 MPa, 7 bar)	89.4 dB(A)
*Sound Power at 30 psi (210 kPa, 2.1 bar)	90.2 dB(A)
*Sound Power at 100 psi (0.7 MPa, 7 bar)	93.9 dB(A)
Wetted Parts	Stainless Steel, Carbide or Engineered Plastic, Ultra High Molecular Weight Polyethylene, Acetal, PTFE®

- \* Sound pressure was measured at 1 meter from the unit. PTFE®  
 Sound power was tested in accordance with ISO  
 9614-2.

## Dimensions

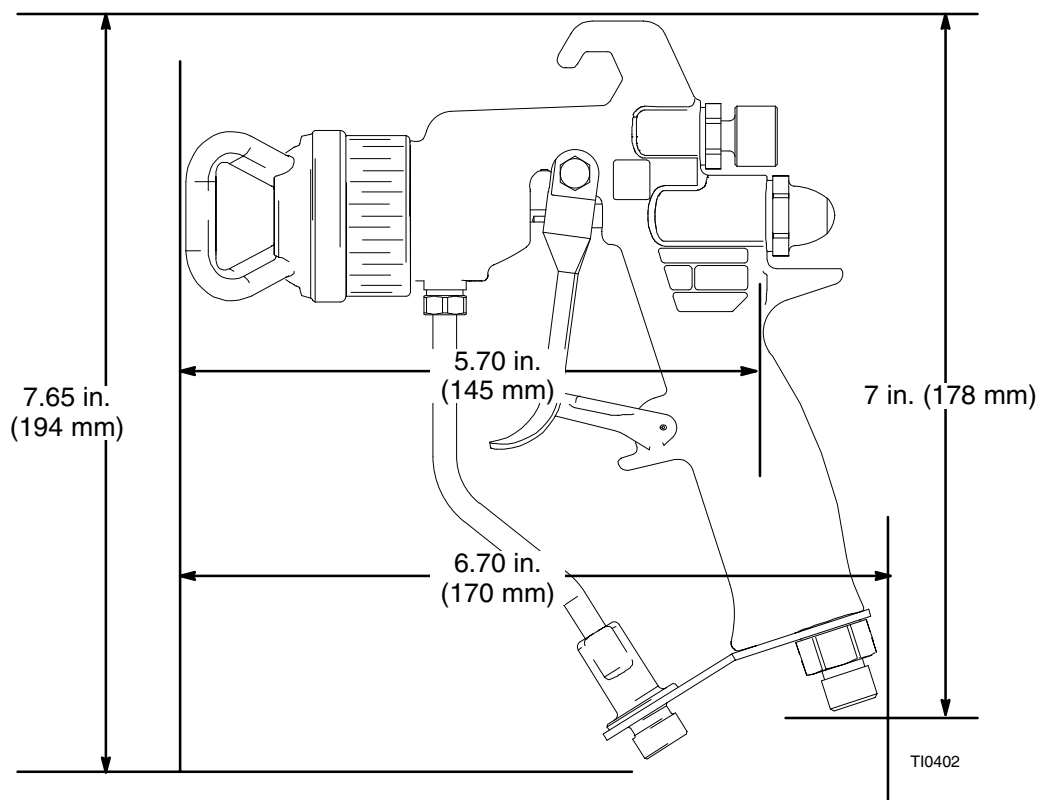

# Graco Standard Warranty

Graco warrants all equipment manufactured by Graco and bearing its name to be free from defects in material and workmanship on the date of sale by an authorized Graco distributor to the original purchaser for use. With the exception of any special, extended, or limited warranty published by Graco, Graco will, for a period of twelve months from the date of sale, repair or replace any part of the equipment determined by Graco to be defective. This warranty applies only when the equipment is installed, operated and maintained in accordance with Graco's written recommendations.

This warranty does not cover, and Graco shall not be liable for general wear and tear, or any malfunction, damage or wear caused by faulty installation, misapplication, abrasion, corrosion, inadequate or improper maintenance, negligence, accident, tampering, or substitution of non-Graco component parts. Nor shall Graco be liable for malfunction, damage or wear caused by the incompatibility of Graco equipment with structures, accessories, equipment or materials not supplied by Graco, or the improper design, manufacture, installation, operation or maintenance of structures, accessories, equipment or materials not supplied by Graco.

This warranty is conditioned upon the prepaid return of the equipment claimed to be defective to an authorized Graco distributor for verification of the claimed defect. If the claimed defect is verified, Graco will repair or replace free of charge any defective parts. The equipment will be returned to the original purchaser transportation prepaid. If inspection of the equipment does not disclose any defect in material or workmanship, repairs will be made at a reasonable charge, which charges may include the costs of parts, labor, and transportation.

**THIS WARRANTY IS EXCLUSIVE, AND IS IN LIEU OF ANY OTHER WARRANTIES, EXPRESS OR IMPLIED, INCLUDING BUT NOT LIMITED TO WARRANTY OF MERCHANTABILITY OR WARRANTY OF FITNESS FOR A PARTICULAR PURPOSE.**

Graco's sole obligation and buyer's sole remedy for any breach of warranty shall be as set forth above. The buyer agrees that no other remedy (including, but not limited to, incidental or consequential damages for lost profits, lost sales, injury to person or property, or any other incidental or consequential loss) shall be available. Any action for breach of warranty must be brought within two (2) years of the date of sale.

Graco makes no warranty, and disclaims all implied warranties of merchantability and fitness for a particular purpose in connection with accessories, equipment, materials or components sold but not manufactured by Graco. These items sold, but not manufactured by Graco (such as electric motors, switches, hose, etc.), are subject to the warranty, if any, of their manufacturer. Graco will provide purchaser with reasonable assistance in making any claim for breach of these warranties.

In no event will Graco be liable for indirect, incidental, special or consequential damages resulting from Graco supplying equipment hereunder, or the furnishing, performance, or use of any products or other goods sold hereto, whether due to a breach of contract, breach of warranty, the negligence of Graco, or otherwise.

## **FOR GRACO CANADA CUSTOMERS**

The parties acknowledge that they have required that the present document, as well as all documents, notices and legal proceedings entered into, given or instituted pursuant hereto or relating directly or indirectly hereto, be drawn up in English. Les parties reconnaissent avoir convenu que la rédaction du présente document sera en Anglais, ainsi que tous documents, avis et procédures judiciaires exécutés, donnés ou intentés à la suite de ou en rapport, directement ou indirectement, avec les procédures concernées.

# Graco Information

**TO PLACE AN ORDER**, contact your Graco distributor, or call one of the following numbers to identify the distributor closest to you:

**1-800-367-4023 Toll-Free**

**612-623-6921**

**612-378-3505 Fax**

*All written and visual data contained in this document reflects the latest product information available at the time of publication.  
Graco reserves the right to make changes at any time without notice.*

**Sales Offices:** Minneapolis, Detroit

**International Offices:** Belgium, Korea, Hong Kong, Japan

**GRACO INC. P.O. BOX 1441 MINNEAPOLIS, MN 55440-1441**

**[www.graco.com](http://www.graco.com)**

PRINTED IN U.S.A. 309117 06/2000 Revised 10/2002