

# Instructions/Parts List



ELECTROSTATIC, WATERBORNE, AIR SPRAY

## WB100 Isolation System and PRO<sup>TM</sup> Xs3 Spray Gun

309293N

EN

For use when electrostatically spraying conductive, waterborne fluids that meet at least one of the following conditions for non-flammability. For professional use only.

### FM Approved

- The fluid has a flash point above 140°F (60°C) and a maximum organic solvent concentration of 20%, by weight, per ASTM Standard D93.
- The fluid does not sustain burning when tested per ASTM Standard D4206 Sustained Burn Test.

### CE-EN 50059 Compliant

- Materials which cannot be ignited, in any mixture with air, by an energy source of less than 500 mJ.



### Important Safety Instructions

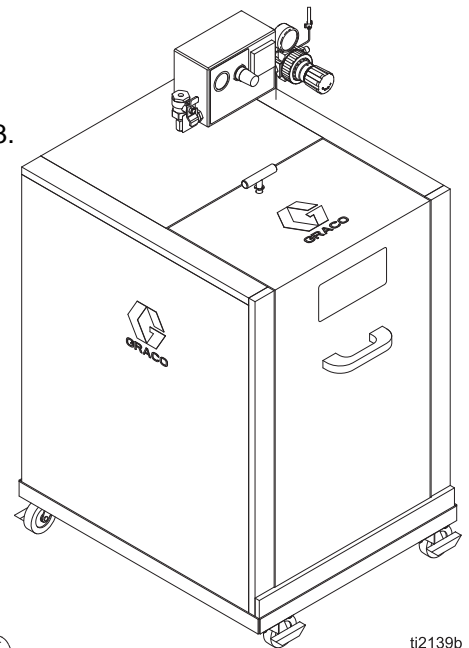
Read all warnings and instructions in this manual.  
Save these instructions.

100 psi (0.7 MPa, 7 bar) Maximum Air Inlet Pressure

100 psi (0.7 MPa, 7 bar) Maximum Working Fluid Pressure

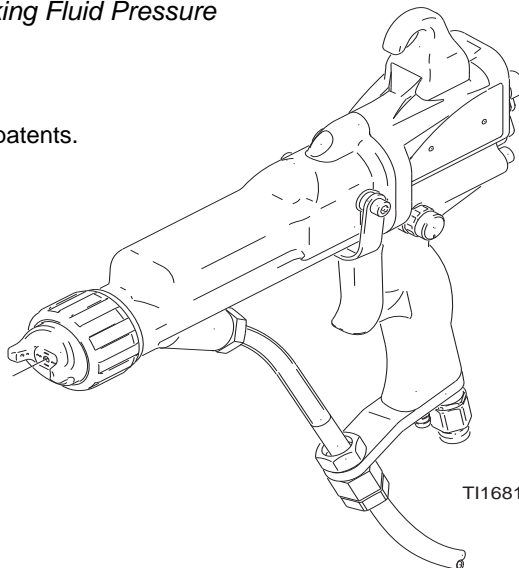
See page 3 for a List of Models

For patent information, see [www.graco.com/patents](http://www.graco.com/patents).



ti2139b

WB 100  
Isolation Enclosure



T11681A



H003

# Table of Contents

<b>List of Models</b> .....	<b>3</b>	<b>Troubleshooting</b> .....	<b>34</b>
<b>Symbols</b> .....	<b>4</b>	Voltage Loss Troubleshooting .....	34
Warning Symbol .....	4	Spray Pattern Troubleshooting .....	37
Caution Symbol .....	4	Gun Operation Troubleshooting .....	38
<b>Warning</b> .....	<b>4</b>	Electrical Troubleshooting .....	39
<b>Warning</b> .....	<b>6</b>	<b>Repair</b> .....	<b>41</b>
<b>Introduction</b> .....	<b>7</b>	Prepare the Gun for Service .....	41
How the Electrostatic Air Spray Gun Works . . . . .	7	Air Cap/Nozzle Replacement .....	42
Spraying Waterborne Fluids Electrostatically . . . . .	7	Electrode Replacement .....	43
Gun Overview .....	8	Fluid Packing Removal .....	44
<b>Installation</b> .....	<b>9</b>	Packing Rod Repair .....	45
System Requirements .....	9	Barrel Removal .....	46
Warning Sign .....	9	Barrel Installation .....	46
Install the System .....	9	Power Supply Removal and Replacement . . . . .	47
Ventilate the Spray Booth .....	11	Turbine Alternator Removal and Replacement . . . . .	48
Connect the Air Line .....	11	Fan Air Adjustment Valve Repair .....	49
Ground the Cabinet .....	11	Fluid Adjustment Valve Repair .....	50
Connect the Waterborne Fluid Hose .....	11	Air Valve Repair .....	50
245895 Agitator Kit .....	14	Atomizing Air Restrictor Valve Removal and	
245944 Fluid Regulator Kit .....	15	Replacement .....	51
Select a Fluid Nozzle and Air Cap .....	16	ES ON/OFF Valve Repair .....	51
Grounding .....	17	<b>Parts</b> .....	<b>52</b>
Check Electrical Grounding .....	18	<b>Accessories</b> .....	<b>65</b>
<b>Operation</b> .....	<b>19</b>	Air Line Accessories .....	65
Operating Checklist .....	19	Fluid Line Accessories .....	65
Fluid Voltage Discharge and Grounding Procedure		Gun Accessories .....	66
20		Miscellaneous Accessories .....	66
Pressure Relief Procedure .....	20	<b>Technical Specifications</b> .....	<b>69</b>
Fill the Fluid Supply .....	21	<b>California Proposition 65</b> .....	<b>69</b>
Adjust the Spray Pattern .....	21	<b>Graco Standard Warranty</b> .....	<b>70</b>
Shutdown .....	25	<b>Graco Information</b> .....	<b>70</b>
Low Voltage Adjustment (Smart Guns Only) . . . . .	25		
<b>Maintenance</b> .....	<b>26</b>		
Flush the Spray Gun .....	26		
Daily Care and Cleaning .....	27		
Clean the Air Cap and Fluid Nozzle .....	29		
Grease Door Latch Threads .....	29		
<b>Electrical Tests</b> .....	<b>30</b>		
Test Gun Resistance .....	30		
Test Power Supply Resistance .....	31		
Test Electrode Resistance .....	32		
Test Ground Strip Resistance .....	33		
Test Cylinder Resistance .....	33		

## List of Models

<b>FM Approved</b>		
<b>Part No.</b>	<b>Gun Model</b>	<b>Description</b>
245897	PRO Xs3	Waterborne Isolation Enclosure with standard electrostatic air spray gun, grounded air hose, and shielded waterborne fluid hose
245898	PRO Xs3	Waterborne Isolation Enclosure with smart electrostatic air spray gun, grounded air hose, and shielded waterborne fluid hose
233825		Waterborne Isolation Enclosure without hoses and gun.
244581, Series B	PRO Xs3	Standard Electrostatic Air Spray Gun, for waterborne coatings
245301,	PRO Xs3	Part No. 244581 Gun, with 25 ft (7.6 m) waterborne fluid hose
244582, Series B	PRO Xs3	Smart Electrostatic Air Spray Gun, for waterborne coatings,
245305	PRO Xs3	Part No. 244582 Gun, with 25 ft (7.6 m) waterborne fluid hose
245252		Shielded Waterborne Fluid Hose Assembly 25 ft (7.6 m)
<b>EN 50059 Compliant</b>		
244581, Series B	PRO Xs3	Standard Electrostatic Air Spray Gun, for waterborne coatings.
244582, Series B	PRO Xs3	Smart Electrostatic Air Spray Gun, for waterborne coatings.
246511		Waterborne Isolation Enclosure, without hoses and gun
246431	PRO Xs3	Unshielded Waterborne fluid hose assembly, 25 ft (7.6 m).
246592	PRO Xs3	Waterborne Isolation Enclosure with standard electrostatic air spray gun, grounded air hose, and unshielded waterborne fluid hose
246593	PRO Xs3	Waterborne Isolation Enclosure with smart electrostatic air spray gun, grounded air hose, and unshielded waterborne fluid hose

# Symbols

## Warning Symbol





This symbol alerts you to the possibility of serious injury or death if you do not follow the instructions.

## Caution Symbol



This symbol alerts you to the possibility of damage to or destruction of equipment if you do not follow the instructions.

 <b>WARNING</b>	
	<p><b>Electric Shock Hazard</b></p> <p>Improper grounding, setup, or usage of an isolated waterborne system can cause a hazardous condition and result in electric shock or other serious injury.</p> <ul style="list-style-type: none"><li>• Ground the equipment, all personnel in or close to the spray area, the object being sprayed, and all conductive objects in the spray area. See <b>Grounding</b>, page 17.</li><li>• The gun must be connected to a voltage isolation system that will discharge the system voltage when the gun is not in use.</li><li>• All components of the isolation system that are charged to high voltage must be contained within an enclosure that prohibits personnel from making contact with the high voltage components before the system voltage is discharged.</li><li>• Follow the <b>Fluid Voltage Discharge and Grounding Procedure</b> on page 20 when instructed to discharge the voltage; before cleaning, flushing, or servicing the system; before approaching the front of the gun; and before opening the safety enclosure for the isolated fluid supply.</li><li>• Do not touch the gun nozzle or come within 4 in. (102 mm) of the nozzle during gun operation or for 30 seconds after operation stops, to allow the voltage to discharge through the bleed resistor. Place the gun in the holster (accessory) during this 30 second period. Refer to <b>Fluid Voltage Discharge and Grounding Procedure</b>, page 20.</li><li>• Electrically connect a metal part of the fluid supply unit to the bleed resistor.</li><li>• The gun air supply must be interlocked with the isolation system to shut off the air supply anytime the isolation system enclosure is opened.</li><li>• Use only the red-colored Graco electrically conductive gun air hose with this gun. Do not use black or grey-colored Graco air hoses.</li><li>• Install only one continuous Graco waterborne fluid hose between the isolated fluid supply and the spray gun. Do not splice hoses together.</li><li>• Do not enter a high voltage or hazardous area until all high voltage equipment has been discharged.</li></ul>


**WARNING**

**Fire and Explosion Hazard**

Improper grounding, poor air ventilation, open flames, or sparks can cause a hazardous condition and result in a fire or explosion.

- Electrostatic equipment must be used only by trained, qualified personnel who understand the requirements in this manual.
- Ground the equipment, all personnel in or close to the spray area, the object being sprayed, and all other electrically conductive objects in the spray area. See **Grounding**, page 17.
- Check gun resistance daily. See **Test Gun Resistance** on page 30.
- If there is any static sparking while using the equipment, **stop spraying immediately**. Identify and correct the problem.
- Provide fresh air ventilation to avoid buildup of flammable or toxic vapors. See **Ventilate the Spray Booth** on page 11.
- Only use this equipment to spray non-flammable, waterborne fluids, as defined on the front cover of this manual.
- Only flush, purge, or clean the electrostatic waterborne spray system with non-flammable fluids, as defined on the front cover of this manual.
- Do not flush with the gun electrostatics turned on.
- Keep the spray area free of debris and rags. Do not store solvent and flammable fluids in the spray area.
- Eliminate all ignition sources such as pilot lights, cigarettes, and static arcs from plastic drop cloths. Do not plug in or unplug power cords or turn lights on or off in the spray area.
- Use only non-sparking tools to clean residue from the booth and hangers.


**Toxic Fluid Hazard**

Hazardous fluids or toxic fumes can cause a serious injury or death if splashed in the eyes or on the skin, swallowed, or inhaled.

- Know the specific hazards of the fluid you are using. Read the fluid manufacturer's warnings.
- Store hazardous fluid in an approved container. Dispose of the hazardous fluid according to all local, state, and national guidelines.
- Wear appropriate protective clothing, gloves, eyewear, and respirator.


**WARNING**

**Equipment Misuse Hazard**

Equipment misuse can cause the equipment to rupture, malfunction, or start unexpectedly and result in a serious injury.

- This equipment is for professional use only.
- Read all manuals, tags, and labels before operating the equipment.
- Use the equipment only for its intended purpose. If you are uncertain, call your Graco distributor.
- Do not alter or modify equipment. Use only genuine Graco parts and accessories.
- Do not operate the power supply above 60 kV. Use only Graco Part No. 244542 Power Supply with this gun.
- Check the equipment daily. Repair or replace worn or damaged parts immediately.
- Do not exceed the maximum working pressure of the lowest rated system component. Maximum working air and fluid pressure of this equipment is 100 psi (0.7 MPa, 7.0 bar).
- Use fluids and solvents that are compatible with the equipment wetted parts. See the **Technical Specifications** section of all equipment manuals. Read the fluid and solvent manufacturer's warnings.
- Route the hoses away from traffic areas, sharp edges, moving parts, and hot surfaces. Do not expose Graco hoses to temperatures above 180°F (82°C) or below -40°F (-40°C).
- Wear hearing protection when operating this equipment.
- Comply with all applicable local, state, and national fire, electrical, and other safety regulations.


**Pressurized Equipment Hazard**

Spray from the gun, hose leaks, or ruptured components can splash fluid in the eyes or on the skin and cause serious injury.

- Do not point the spray gun at anyone or at any part of the body.
- Do not stop or deflect fluid leaks with your hand, body, glove, or rag.
- Follow the **Pressure Relief Procedure**, page 20, when you stop spraying and before cleaning, checking, or repairing equipment.
- Check hoses and couplings daily. Replace worn, damaged, or loose parts immediately.
- Tighten all fluid connections before each use.

# Introduction

## How the Electrostatic Air Spray Gun Works

The air hose supplies air to the spray gun. Part of the air operates the turbine and the rest of the air atomizes the fluid being sprayed. The turbine generates power, which is converted by the power cartridge to supply high voltage current to the gun's electrode.

The fluid source supplies fluid to the hose and gun. The gun must be connected to a voltage isolation system to maintain voltage at the gun. In an isolation system, the entire fluid supply is electrostatically charged. The charged fluid is attracted to the grounded workpiece, wrapping around and evenly coating all surfaces.

## Spraying Waterborne Fluids Electrostatically

This electrostatic air spray gun is designed to spray **only** waterborne fluids with a flash point above 140°F (60°C) and a maximum organic solvent concentration of 20%, by weight, per ASTM Standard D93. Also, the fluid must not sustain burning when tested per ASTM Standard D4206 Sustained Burn Test.

When connected to a voltage isolation system, all of the fluid in the spray gun, fluid hose, and isolated fluid supply is charged to high voltage, which means that the system has more electrical energy than a solvent-based system. Therefore, only non-flammable fluids (as defined on the front cover of this manual) can be sprayed with the system or be used to clean, flush, or purge the system.

Precautions must be taken when using electrostatic waterborne equipment to avoid potential shock hazards. When the spray gun charges the isolated fluid to high voltage, it is similar to charging a capacitor or a battery. The system will store some of the energy while spraying and retain some of that energy after the spray gun is shut off. It is not safe to touch the front end of the gun until the stored energy is discharged. The amount of time it takes to discharge the energy depends on the system design. Follow the **Fluid Voltage Discharge and Grounding Procedure** on page 20 before approaching the front of the gun.



The Graco warranty is void if the spray gun is connected to a non-Graco voltage isolation system or if the gun is operated above 60 kV.

## Gun Overview

The electrostatic gun includes the following controls (see FIG. 1.).

- **FLUID adjustment valve.** Adjusts fluid rod travel. Use only in low flow conditions, to reduce wear.
- **Fan AIR adjustment valve.** Adjusts fan size and shape.
- **Atomizing air RESTRICTOR valve.** Restricts atomizing air flow. Replace with plug (included) if desired.

- **ES ON/OFF valve.** Turns electrostatics ON (I) or OFF (O).
- **ES INDICATOR (standard gun only).** Green when ES is ON (I).
- **Voltage/current DISPLAY (smart models only).** Shows voltage (V) and current (A). Green=spray, yellow/red=see **Electrical Troubleshooting**, page 39.
- **ES HI/LO switch (smart models only).** Sets voltage to HI or LO (factory settings).
- **LO VOLTAGE adjustment (smart models only).** Remove plug to adjust to four settings. Page 21.

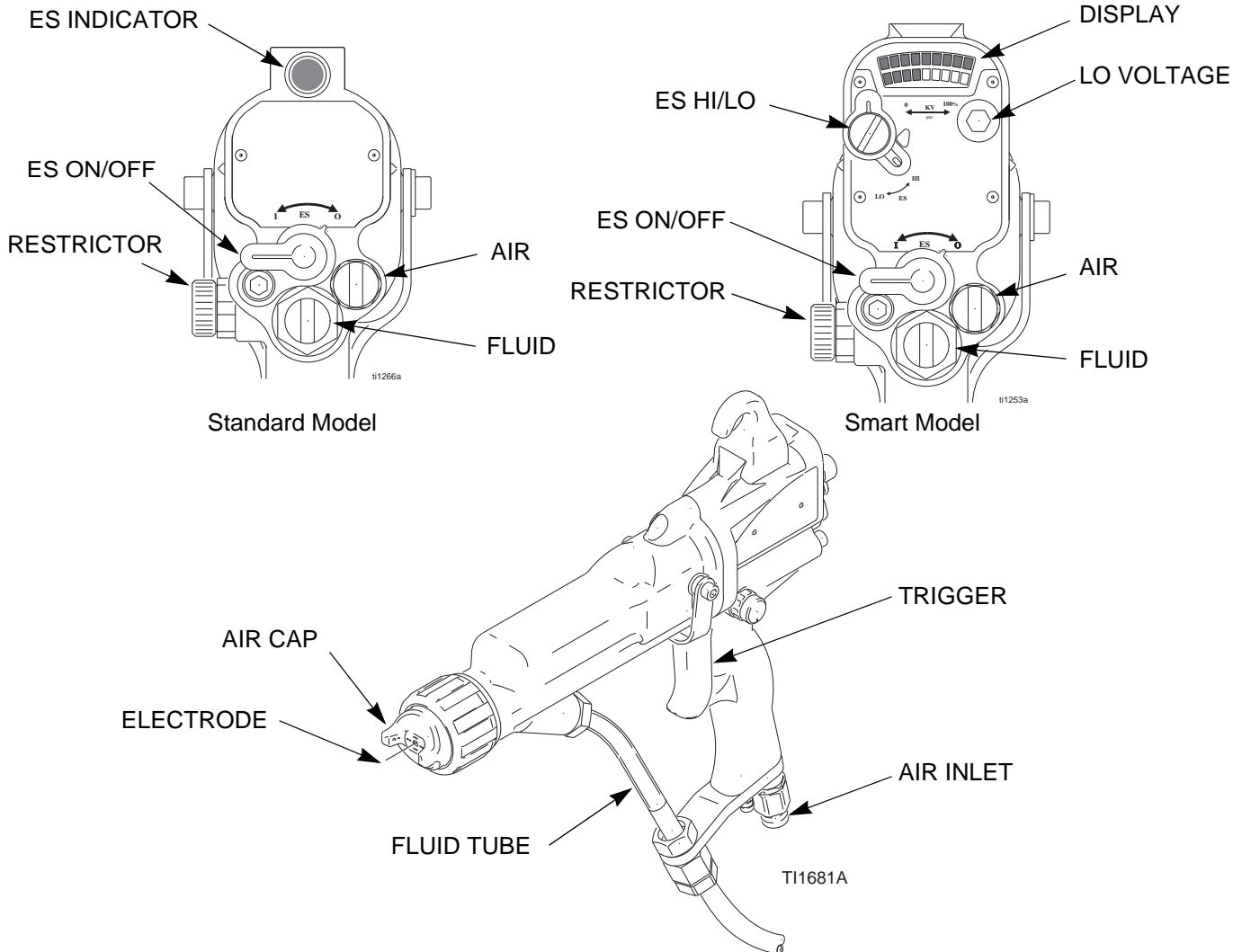


Fig. 1. Gun Overview



# Installation

## System Requirements

A safe, well designed voltage isolation system should have the following features:

- All components of the isolation system that are charged to high voltage must be contained within an enclosure that prohibits persons from making contact with the high voltage components before the system voltage is discharged.
- A bleed resistor to drain off the system voltage when the spray gun is not in use.
- The system should not have any severe arcing occurring when the isolation mechanism opens and closes. Severe arcing will shorten the life of the system components.
- The system must include a means for automatically discharging the system voltage when anyone opens the isolation enclosure.

### CAUTION

The Graco warranty is void if the spray gun is connected to a non-Graco voltage isolation system or if the gun is operated above 60 kV.

## Warning Sign

Mount the warning sign, Part No. 186118, in the spray area where it can be seen and read by all operators. Additional warning signs are available at no charge.

## Install the System

### WARNING

#### Fire, Explosion, and Electric Shock Hazard

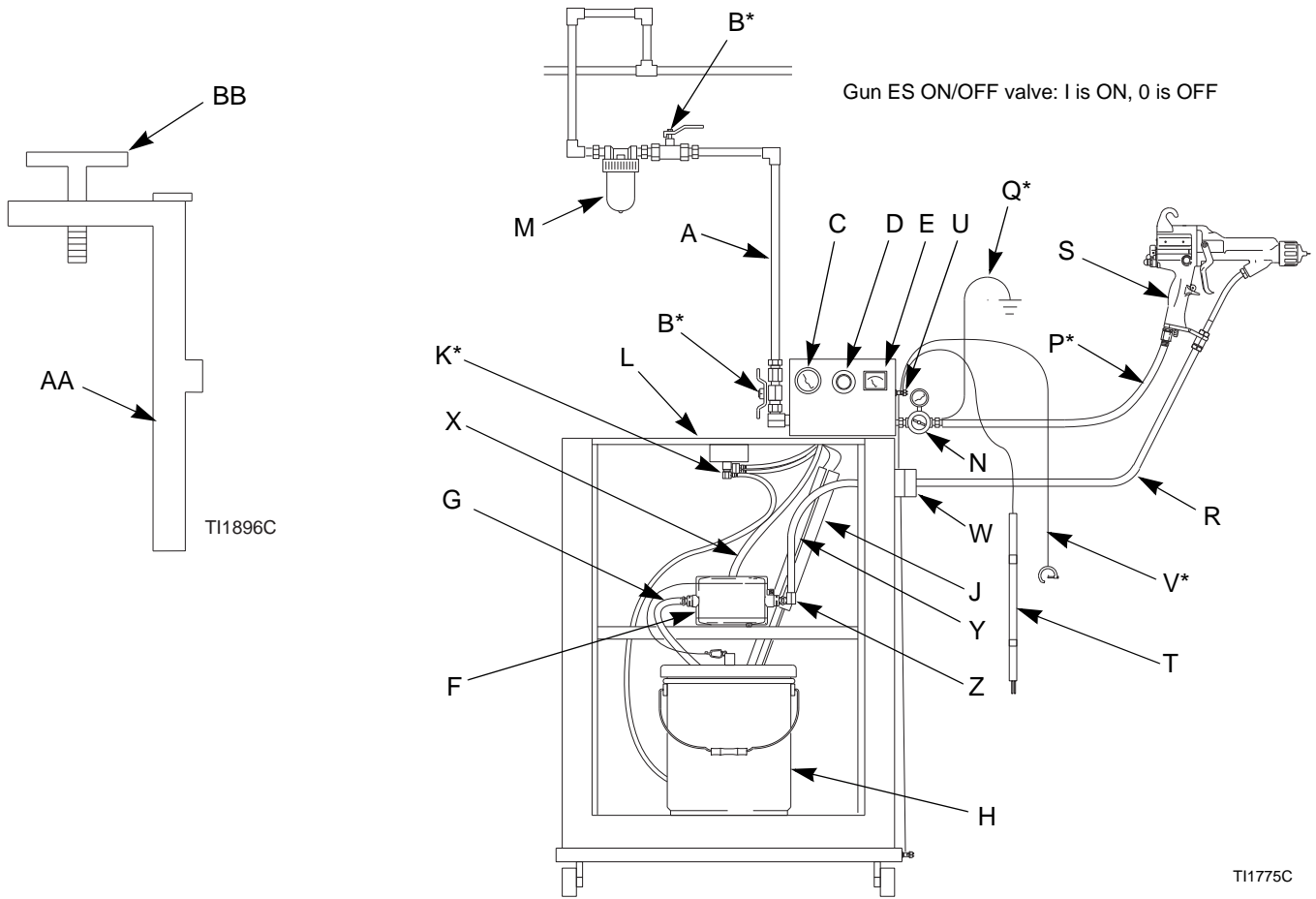


Installing and servicing this equipment requires access to parts which may cause electric shock or other serious injury if work is not performed properly.

•Do not install or service this equipment unless you are trained and qualified.

•Be sure your installation complies with all National, State and Local safety and fire codes, NFPA 33, NEC 504 and 516, and OSHA standard 1910.107.

FIG. 2. on page 10 shows a PRO Xs electrostatic water-borne air spray system. For assistance in designing a system to suit your particular needs, contact your Graco distributor.



**Fig. 2. Typical Installation: PRO Xs Waterborne System**  
**Key**

- |    |  |    |  |
|----|--|----|--|
| A  | Main Air Supply Line                       | S  | Waterborne Electrostatic Air Spray Gun                     |
| B* | Main Air Supply Shutoff Valve (bleed-type) | T  | Grounding Rod  |
| C  | Pump Air Pressure Gauge                    | U  | Ground Terminal  |
| D  | Pump Air Pressure Regulator                | V* | Main Ground Wire   |
| E  | kV Meter                                   | W  | Strain Relief/Ground Fitting                               |
| F  | Pump                                       | X  | Pump Air Supply Line                                       |
| G  | Pump Suction Hose                          | Y  | Grounding Cylinder   |
| H  | Paint Container                            | Z  | Pump Fluid Outlet Fitting                                  |
| J  | Bleed Resistor                             | AA | Isolated Enclosure Door                                    |
| K* | Enclosure Safety Interlock                 | BB | Enclosure T-Handle Locking Screw                           |
| L  | Isolated Enclosure                         |    |  |
| M  | Gun Air Line Filter                        |    |  |
| N  | Gun Air Pressure Regulator                 |    |  |
| P* | Graco Red Grounded Air Supply Hose         |    |  |
| Q* | Air Hose Ground Wire                       |    |  |
| R  | Graco Waterborne Fluid Hose                |    |  |
|    |  | *  | Required for safe operation. Must be purchased separately. |

## Ventilate the Spray Booth

### WARNING

#### Flammable or Toxic Vapor Hazard



Provide fresh air ventilation to avoid the buildup of flammable or toxic vapors. Do not operate the gun unless ventilation fans are operating.



Check and follow all National, State, and Local codes regarding air exhaust velocity requirements.

**NOTE:** High velocity air exhaust will decrease the operating efficiency of the electrostatic system. The minimum allowable air exhaust velocity is 60 linear ft/min (18.3 linear meters/minute).

## Connect the Air Line

### WARNING

#### Electric Shock Hazard



To reduce the risk of electric shock or other serious injury, you must use the red-colored Graco Electrically Conductive Air Hose for the gun air supply hose, and you must connect the hose ground wire to a true earth ground. Do not use the black or grey-colored Graco air hoses.

1. Install an air line filter/water separator (M) on the main air supply line to ensure a dry, clean air supply to the gun. Dirt and moisture can ruin the appearance of your finished workpiece and can cause the gun to malfunction.
2. Install a bleed-type air regulator (N) on the gun air line (P).
3. Connect the red-colored Graco Grounded Air Supply Hose (P) between the gun air regulator (N) and the gun's air inlet. The gun air inlet fitting has a left-hand thread. Connect the air supply hose ground wire (Q) to a true earth ground.

4. Connect the main air supply line (A) to the bleed-type air valve (B). The bleed valve shuts off all air to the system. Install an additional bleed-type air valve (B) upstream of the air filter (M) to isolate the filter for servicing.

### WARNING

#### Pressurized Equipment Hazard



The bleed-type air valve (B) is required in your system to relieve air trapped between the valve and the fluid supply unit after the air regulator (D) is shut off. Trapped air can cause the fluid supply unit to cycle unexpectedly, which can result in serious injury, including splashing fluid in the eyes or on the skin.

## Ground the Cabinet

Connect the main ground wire (V) to a true earth ground.

## Connect the Waterborne Fluid Hose

Always use a Graco waterborne fluid hose between the voltage isolation system fluid outlet and the gun fluid inlet. See FIG. 3.. The waterborne fluid hose (101) consists of an inner PTFE tube (T) and an abrasion-resistant outer jacket (J). Shielded hose 245252 also has a conductive layer (C). The conductive layer is connected to ground at the gun fitting bracket (104).

Before connecting the waterborne fluid hose to the gun, blow it out with air and flush with water to remove contaminants. Flush the gun before using it.

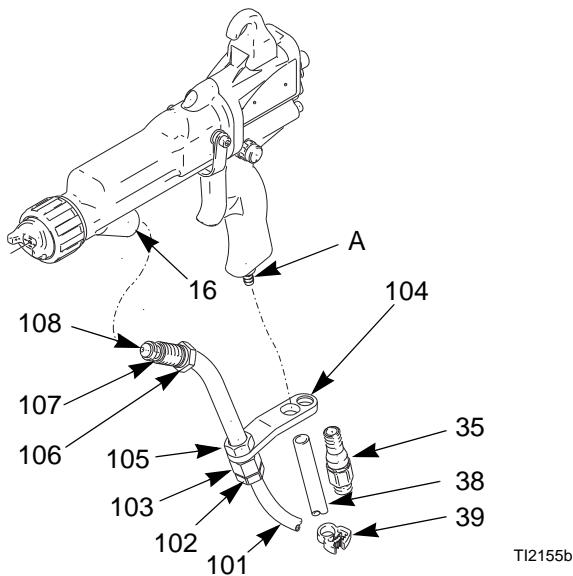
### WARNING

#### Electric Shock Hazard



To reduce the risk of electric shock, install only one continuous Graco waterborne hose between the isolated fluid supply and the gun. Do not splice hoses together.

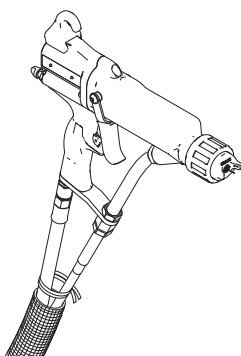
1. Remove the gun air inlet fitting (35). See FIG. 3.



**Fig. 3. Connect the Fluid Hose**

**NOTE:** In a shielded hose system, if a hose failure occurs where high voltage arcs through the inner tube, voltage will be discharged to ground through the conductive hose layer. When properly installed, the conductive hose layer is grounded through its connection to the grounded enclosure.

Using unshielded fluid hoses minimizes the system capacitance, resulting in faster response times and a large reduction in the energy stored in the system, as compared to shielded hoses. However, without the ground shield, a weak static charge can occasionally build up on the outer surface of the hose. To minimize any static charge felt on the hose surface, bundle the air and fluid hose together, and wrap with a protective cover, as shown in FIG. 4.



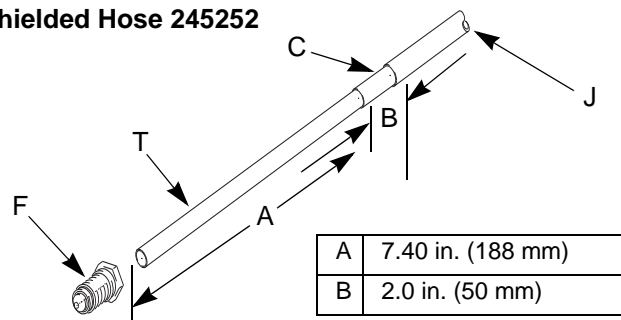
**Fig. 4. Bundling the Air and Fluid Hoses**

2. For the fluid hose to fit properly, it must be stripped and assembled to the dimensions in FIG. 5. Push the inner tube (T) into the fitting (F) until the tube bottoms. A new Graco waterborne fluid hose comes fully assembled to these dimensions.

**CAUTION**

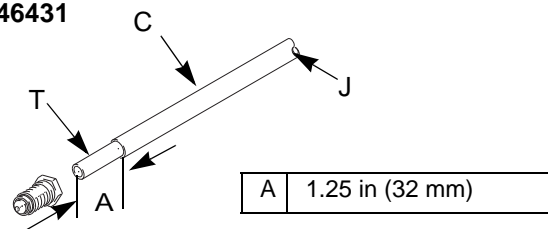
Be careful not to cut into the inner tube (T) of the hose when stripping the hose. Nicks or cuts in the PTFE tube will cause premature hose failure.

**Shielded Hose 245252**



**Fig. 5. Waterborne Hose Dimensions (At Gun)**

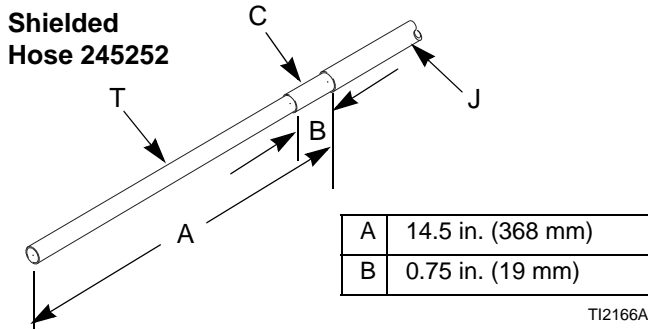
**Unshielded  
Hose 246431**



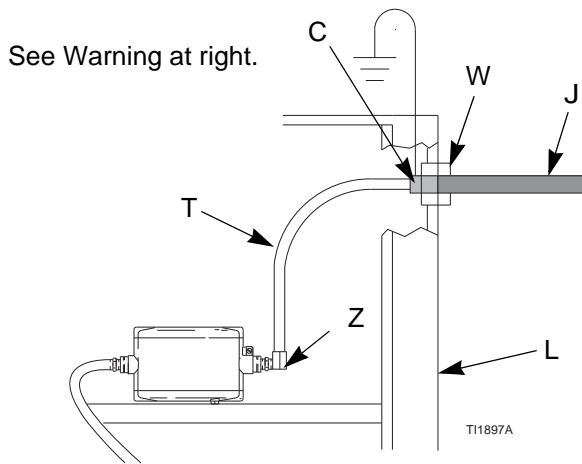
**Fig. 6.**

3. Generously apply dielectric grease (40) to the o-ring (107) and the threads of the fitting (106). Pull the fitting back 1-1/2 in. (38 mm) and apply grease to the exposed PTFE hose to fill the area between the hose and the fitting. Make sure the barrel inlet is clean and dry, then screw the fitting into the fluid inlet of the gun barrel (16). See FIG. 3.
4. Loosen the strain relief nut (102) so the bracket can move freely on the hose.
5. Align the bracket (104) holes with the air inlet and exhaust outlet. Secure with the air inlet fitting (35). Tighten the strain relief nut (102) to secure the hose.

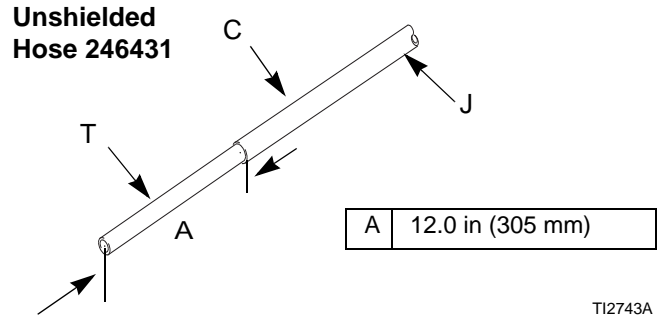
6. Check that the nut (105) is tightened securely to the ferrule housing (103).
7. Press the exhaust tube (38) onto the barbed adapter (A). Secure with the clamp (39).
8. Connect the other end of the hose to the isolated fluid supply as follows:
  - a. *Graco WB100 Enclosure:* Slide hose through the strain relief fitting (W). Ensure conductive layer (C) has passed through fitting. Tighten to 55 in-lb (6.2 N•m). Pull back on hose to check it is secure. Comply with the requirements in **Warning** at right. See FIG. 7. and FIG. 8..



**Fig. 7. Waterborne Hose Dimensions (At Graco WB100 Enclosure)**

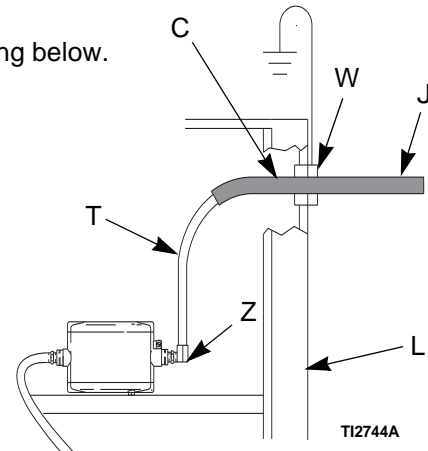


**Fig. 8. Shielded Fluid Hose Connection at Graco WB100**



**Fig. 9.**

See Warning below.



**Fig. 10. Unshielded fluid connection**

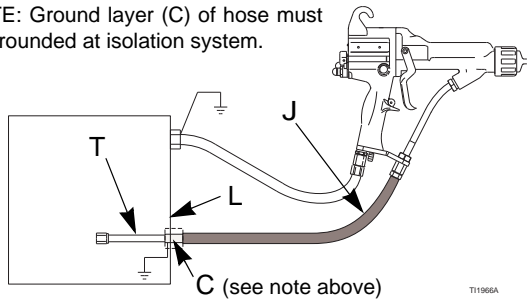
## ! WARNING

**Electric Shock Hazard**

For Shielded hose systems:  
 Conductive hose layer (C) must be grounded through its connection to the isolation system's grounded enclosure (L) or grounded safety fence. To maintain grounding continuity, the conductive hose layer (C) must be engaged in the ferrule when the strain relief nut is tightened. Failure to properly install the hose in the strain relief could result in an electric shock.

- b. *Non-Graco Isolated Enclosure:* Connect hose as instructed in the isolation system manual, and comply with the requirements in the **Warning** at right. Refer to FIG. 11..

NOTE: Ground layer (C) of hose must be grounded at isolation system.



**Fig. 11. Shielded Fluid Hose Connection at Non-Graco Isolated Enclosure**

- c. Connect the end of the tube (T) to the pump fluid outlet fitting (Z).

<b>CAUTION</b>
<p>The Graco warranty is void if the spray gun is connected to a non-Graco voltage isolation system or if the gun is operated above 60 kV.</p>

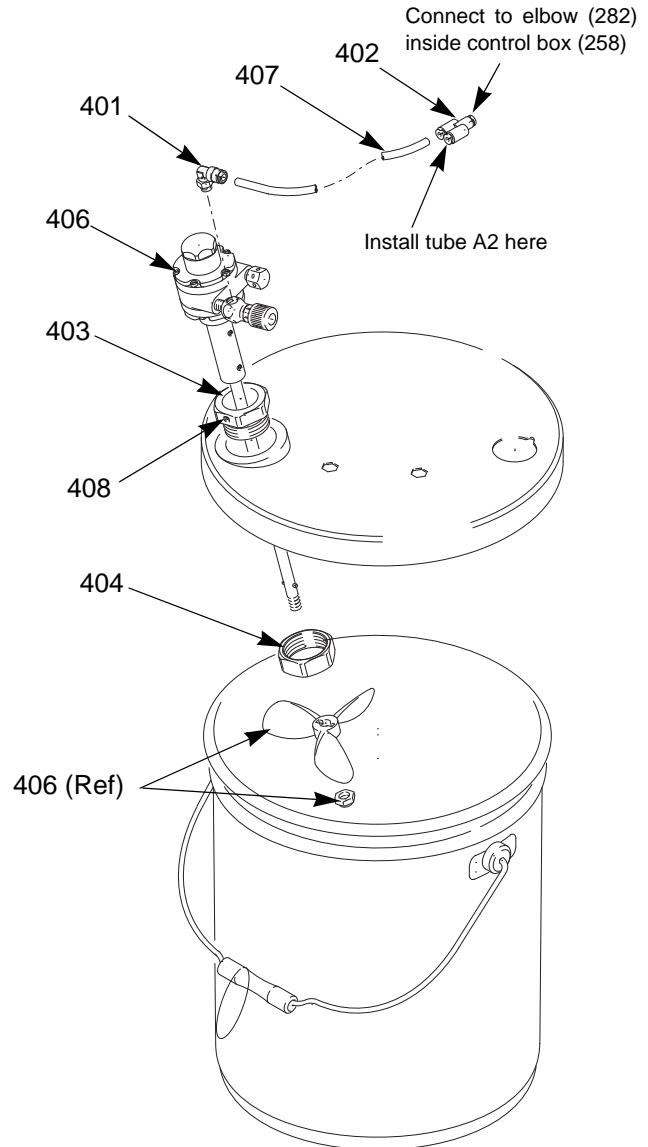
<b>CAUTION</b>
<p>Factory Mutual approval is valid only when this gun is used with Factory Mutual approved voltage isolation systems.</p>

## 245895 Agitator Kit

To add an agitator to the Graco isolation system, order Part No. 245895. See page 67 for the kit parts list.

1. Discharge the system voltage (page 20).
2. Relieve the pressure (page 20).
3. Open the isolated enclosure door.
4. Remove the back of the control box (258).
5. Remove tube (A2) from elbow (282) at the air manifold; see the tubing diagram on page 64. Install the Y fitting (402) into the elbow. Install tubes (A2) and (407) into the Y fitting. See FIG. 12.. Route the agitator tube (407) into the cabinet.
6. Replace the back of the control box (258).

7. Assemble the other parts of the kit as shown. Secure the agitator with the setscrew (408).
8. Return the system to service.



**Fig. 12. 245895 Agitator Kit**

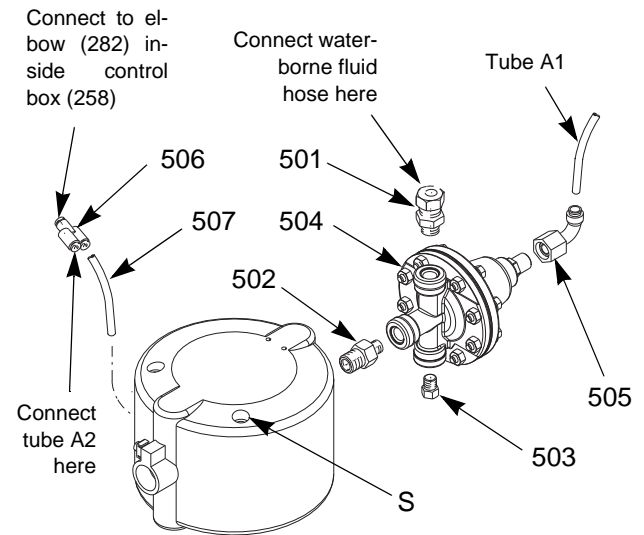
TI2137A

## 245944 Fluid Regulator Kit

To add a fluid regulator to the Graco isolation system, order Part No. 245944. See page 68 for the kit parts list.

1. Discharge the system voltage (page 20).
2. Relieve the pressure (page 20).
3. Open the isolated enclosure door.
4. Remove the 1/4 OD tube (A1) from the pump air inlet; see the tubing diagram on page 64.
5. Remove the waterborne fluid hose from the pump fluid outlet fitting (231) and remove the fitting.
6. Unscrew the two pump mounting screws (S, FIG. 13.) and remove the pump from the isolation enclosure.
7. Remove the back of the control box (258).
8. Remove tube (A2) from elbow (282) at the air manifold; see page 64. Install the Y fitting (506) in the elbow. Install tubes (A2) and (507) into the Y fitting. Route the tube (507) into the cabinet.
9. Replace the back of the control box (258).
10. Assemble the fluid regulator kit as shown in FIG. 13..
11. Reinstall the pump in the isolation enclosure. Use the two mounting holes to the left of the holes used previously, to allow clearance for the fluid regulator.
12. Connect tube (A1) to the air inlet of fluid regulator (504). Connect tube (507) to the pump air inlet.
13. Connect the waterborne fluid hose to the fluid regulator outlet fitting (501).
14. Return the system to service.


**NOTE:** The cabinet air regulator and gauge (216, 217) will now operate the air piloted fluid regulator (504). The pump will now operate at the inlet air pressure.



TI2149A


**Fig. 13. Fluid Regulator Kit**

## Select a Fluid Nozzle and Air Cap



### WARNING

**Pressurized Equipment Hazard**

 To reduce the risk of an injury, follow the **Pressure Relief Procedure** on page 20 before removing or installing a fluid nozzle and/or air cap.

The gun is supplied with Part No. 197266 Nozzle and 24A276 Air Cap. If you require a different size, refer to Table 1 and Table 2, and instruction manual 309419, or consult with your Graco distributor. See **Air Cap/Nozzle Replacement** on page 42.

A wide pattern kit (P/N 24A431) is included with the gun and if installed, will provide fan air for wider spray patterns. (If pattern becomes split, use the fan air valve to reduce the amount of fan air.)

**Table 1: Fluid Nozzles**

Part No.	Size, mm (in.)	Part No.	Size, mm (in.)
197263	0.75 (.030)	197266	1.5 (.055)
197264	1.0 (.042)	197267	1.8 (.070)
197265	1.2 (.047)	197268	2.0 (.080)

**Table 2: Air Caps**


Part No.	Pattern Shape and Length in. (mm)	Recommended Fluids and Production Rates
24A438	Round end; 15-17 (381-432)	Light to medium viscosity. Up to 15 oz/min (450 cc/min)
24A279	Round end; 14-16 (356-406)	Medium to high viscosity and high solids. Up to 15 oz/min (450 cc/min)
24A376*	Tapered end; 17-19 (432-483)	Light to medium viscosity. Up to 15 oz/min (450 cc/min)
24A274	Tapered end; 12-14 (305-356)	Light to medium viscosity. Up to 15 oz/min (450 cc/min)
24A439	Round end; 11-13 (279-330)	Medium to high viscosity and high solids. Up to 15 oz/min (450 cc/min) For use with 2.0 mm nozzle.

\* Also available in the following colors:




- 24A276 - blue
- 24A277 - red
- 24A278 - green



# Grounding


WARNING

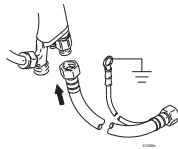
**Fire, Explosion, and Electric Shock Hazard**

When operating the electrostatic gun, any ungrounded objects in the spray area (people, containers, tools, etc.) can become electrically charged. Improper grounding can result in static sparking, which can cause a fire, explosion, or electric shock. Follow the grounding instructions below.

The following are minimum grounding requirements for a basic electrostatic waterborne system. Your system may include other equipment or objects which must be grounded. Check your local electrical code for detailed grounding instructions. Your system must be connected to a true earth ground.

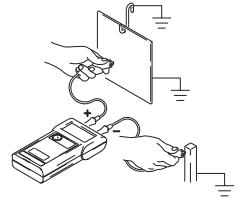
- *Electrostatic Air Spray Gun:* ground the gun by connecting the red-colored Graco Grounded Air Hose and connecting the air hose ground wire to a true earth ground. See **Check Electrical Grounding**, page 18.



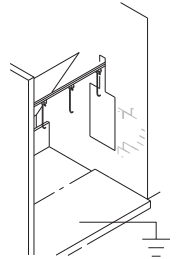
- *Graco Waterborne Fluid Hose:* the hose is grounded through the conductive layer. Install the hose as instructed on page 11.
- *All persons entering the spray area:* shoes must have conductive soles, such as leather, or personal grounding straps must be worn. Do not wear shoes with non-conductive soles such as rubber or plastic. If gloves are necessary, wear the conductive gloves that are supplied with the gun. If non-Graco gloves are worn, cut off fingers or palm area of glove to ensure your hand contacts the grounded gun handle.



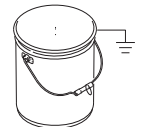
- *Voltage Isolation System:* electrically connect to a true earth ground, as instructed in the voltage isolation system manual.
- *Object being sprayed:* keep the workpiece hangers clean and grounded at all times. Resistance must not exceed 1 megohm.



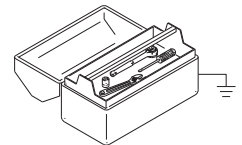
- *The floor of the spray area:* must be electrically conductive and grounded. Do not cover the floor with cardboard or any non-conductive material which would interrupt grounding continuity.



- *All solvent pails:* use only grounded metal pails, which are conductive. Do not use plastic containers. Do not place the pail on a non-conductive surface such as paper or cardboard. Do not store more than the quantity needed for one shift.

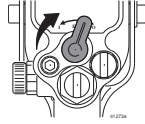


- *All electrically conductive objects or devices in the spray area:* including fluid containers, tools, and wash cans, must be properly grounded.

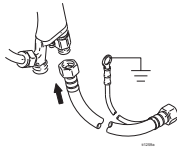


## Check Electrical Grounding

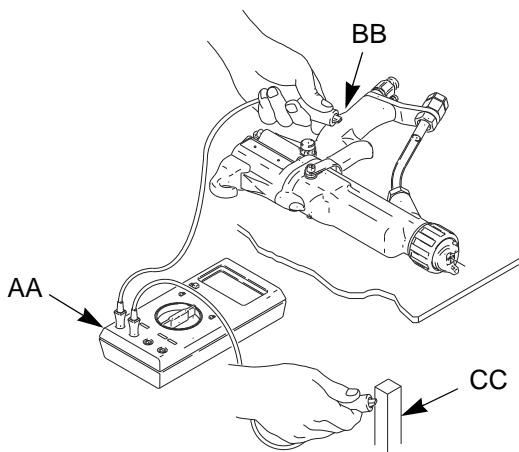
1. Have a qualified electrician check the electrical grounding continuity of the spray gun and air hose.
2. Turn the ES ON/OFF valve OFF.



3. Turn off the air and fluid supply to the gun. The fluid hose must not have any fluid in it.
4. Make sure the red-colored grounded air hose (R) is connected and the hose ground wire is connected to a true earth ground.



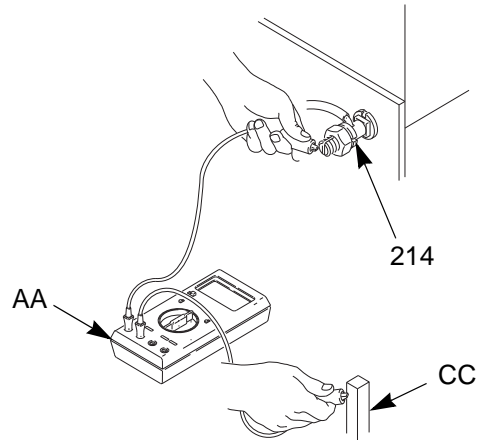
5. Using an ohmmeter (AA), measure the resistance between the gun handle (BB) and a true earth ground (CC). The resistance should not exceed 100 ohms. See FIG. 14..
6. If the resistance is greater than 100 ohms, check the tightness of the ground connections and be sure the air hose ground wire is connected to a true earth ground. If the resistance is still too high, replace the air hose.



TI2161A

Fig. 14. Check Gun Grounding

7. Using an ohmmeter (AA), measure the resistance between the cabinet ground lug (214) and a true earth ground (CC). See FIG. 15.. The resistance must be less than 100 ohms.



TI2163A

Fig. 15. Check Cabinet Grounding

# Operation

## Operating Checklist

Check the following list daily, before starting to operate the system, to help ensure you of safe, efficient operation.

- All operators are properly trained to safely operate an electrostatic waterborne air spray system as instructed in this manual.
- All operators are trained in the **Pressure Relief Procedure** on page 20.
- The electrostatics are turned off and properly grounded according to the **Fluid Voltage Discharge and Grounding Procedure** on page 20 before any person enters the safety enclosure, before cleaning, and before performing any maintenance or repair.
- The system is thoroughly grounded and the operator and all persons entering the spray area are properly grounded. See **Grounding** on page 17.
- Fluid Hose is in good condition with no cuts or abrasions of the PTFE layer. Replace hose if damaged.
- Ventilation fans are operating properly.
- Workpiece hangers are clean and grounded.
- All debris, including flammable fluids and rags, is removed from the spray area.
- Only fluids with a flash point above 140°F (60°C) and a maximum organic solvent concentration of 20%, by weight, may be in the spray area.
- All conductive objects in the spray area are electrically grounded and the floor of the spray area is electrically conductive and grounded.

## Fluid Voltage Discharge and Grounding Procedure

### WARNING

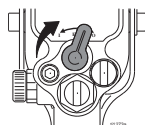
#### Electric Shock Hazard



The fluid supply is charged with high voltage until the voltage is discharged. Contact with the charged components of the isolation system or spray gun electrode will cause an electric shock. To avoid an electric shock, follow the **Fluid Voltage Discharge and Grounding Procedure**:

- whenever you are instructed to discharge the voltage
- before cleaning, flushing, or servicing the system equipment
- before approaching the front of the gun
- or before opening the safety enclosure for the isolated fluid supply.

1. Turn the ES ON/OFF valve OFF and wait 30 seconds.



2. Remove the door T-handle locking screw. This will shut off the air to the gun and trigger the grounding cylinder to discharge any remaining electrical charge.
3. Use the grounding rod to touch the pump and supply pail. If you see any arcs, see **Electrical Troubleshooting** on page 39.

## Pressure Relief Procedure

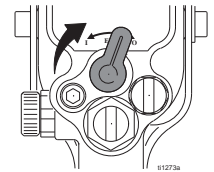
### WARNING

#### Pressurized Equipment Hazard

The system pressure must be manually relieved to prevent the system from starting or spraying accidentally. To reduce the risk of an injury from electric shock, accidental spray from the gun, splashing fluid, or moving parts, follow the **Pressure Relief Procedure** whenever you:

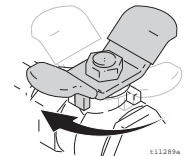
- are instructed to relieve the pressure
- stop spraying
- check or service any of the system equipment
- or install or clean the fluid nozzle.

1. Turn the ES ON/OFF valve OFF.

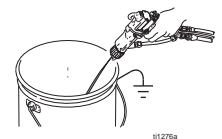


2. Follow the **Fluid Voltage Discharge and Grounding Procedure** at left.

3. Turn off the main air supply valve (B).



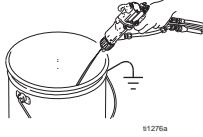
4. Trigger the gun into a grounded metal waste container to relieve the air and fluid pressure.



5. Relieve fluid pressure in the fluid supply unit as instructed in your fluid supply unit manual.

## Fill the Fluid Supply

1. Discharge the system voltage (page 20).
2. Relieve the pressure (page 20).



3. Open the isolated enclosure door.
4. Remove the pail cover from the pail, holding a rag over the suction tube strainer to prevent any fluid from dripping into the isolated enclosure. Place the cover and suction tube outside the enclosure.
5. Remove the supply pail from the enclosure.

### CAUTION

Be sure to wipe up all fluid spills in the isolated enclosure. Fluid can create a conductive path and cause the system to short out.

6. Clean up any fluid spills in the enclosure, using a soft cloth and a non-flammable, compatible solvent.
7. Fill the supply pail with fluid and return it to the enclosure. Clean up any spills.
8. Reinstall the pail cover, holding a rag over the suction tube strainer to prevent fluid spills while you place the pump suction tube in the pail.
9. Close the isolated enclosure door and fasten securely with the T-handle locking screw.

## Adjust the Spray Pattern

Follow the steps below to establish the correct fluid flow and air flow.

### WARNING

#### Fire and Explosion Hazard



To reduce the risk of fire and explosion, only use this equipment with fluids that meet at least one of the following conditions for non-flammability:



- The fluid has a flash point above 140°F (60°C) and a maximum organic solvent concentration of 20%, by weight, per ASTM Standard D93.
- The fluid does not sustain burning when tested per ASTM Standard D4206 Sustained Burn Test.

### WARNING

#### Electric Shock Hazard



Contact with the charged components of the spray gun will cause an electric shock. Do not touch the gun nozzle or electrode or come within 4 in. (102 mm) of the front of the gun during operation or until performing the **Fluid Voltage Discharge and Grounding Procedure** on page 20.

Follow the **Fluid Voltage Discharge and Grounding Procedure** on page 20 when you stop spraying and whenever you are instructed to discharge the voltage.

### WARNING

#### Component Rupture Hazard



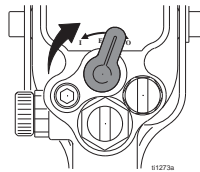
To reduce the risk of component rupture, which can cause serious injury, do not exceed the maximum working pressure of the lowest rated system component. This equipment has a 100 psi (0.7 MPa, 7 bar) maximum working air and fluid pressure.

# ! WARNING

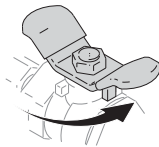
## Pressurized Equipment Hazard

To reduce the risk of an injury, follow the **Pressure Relief Procedure** on page 20 whenever you are instructed to relieve the pressure.

1. Make sure the ES ON/OFF valve is OFF.



2. Turn on the main air supply valve (B).



3. Position the air cap by loosening the air cap retaining ring, and rotating the air cap for a vertical or horizontal spray pattern. Tighten the retaining ring until the air cap is held firmly in place; you should not be able to rotate the air cap horns by hand.



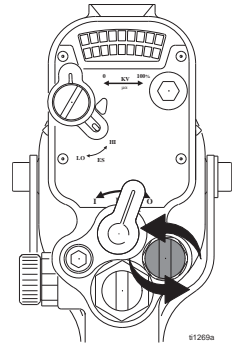
Vertical Pattern



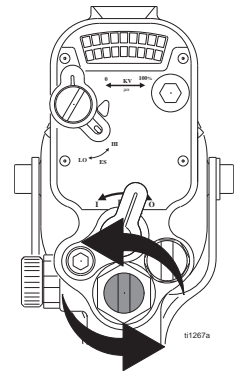
Horizontal Pattern



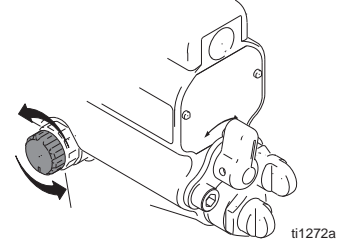
4. Fully open the fan air adjustment valve.



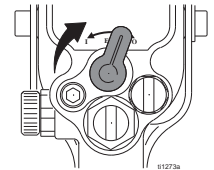
5. Fully open the fluid adjustment valve.



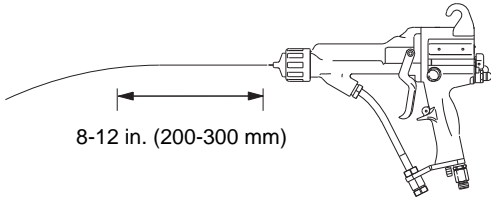
6. Fully open the atomizing air restrictor valve.



7. Make sure the ES ON/OFF valve is OFF.

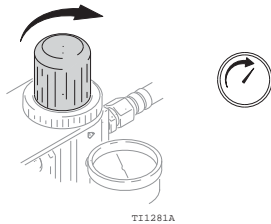


- Adjust the pump air regulator to start the fluid supply unit. Adjust the fluid flow with the air pressure regulator until the stream from the gun travels 8-12 in. (200-300 mm) before falling off. Typically, if fluid pressure is below 5 psi (.04 MPa, 0.4 bar) or above 20 psi (0.14 MPa, 1.4 bar), a change of nozzle size is recommended. Refer to instruction manual 309419 to set the fluid pressure for various fluid flows, according to the size of the fluid nozzle being used.



T11760A

- Set the gun air regulator to deliver a minimum 40 psi (0.28 MPa, 2.8 bar) at the gun when triggered, for maximum transfer efficiency. See Table 3 .



T11281A

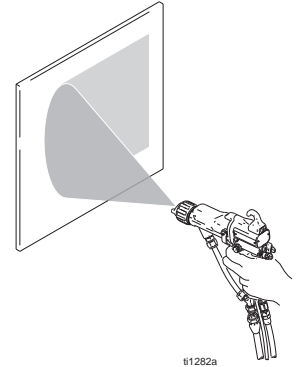
**Table 3: Air Regulator Settings**

Air Hose Length ft (m) (5/16 in. [8 mm] diameter)	Air Regulator Setting psi (MPa, bar) (with gun triggered)
15 (4.6)	50 (0.35, 3.5)
25 (7.6)	60 (0.42, 4.2)
50 (15.3)	75 (0.52, 5.2)

**NOTE:**

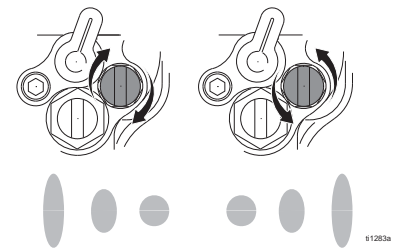
- For the most efficiency, always use the lowest air pressure possible.
- When increasing to a wide, flat pattern, it may be necessary to increase the supply of fluid to the gun to maintain the same amount of coverage over a large area.

- Spray a test pattern. Check the atomization. If over-atomization occurs at minimum pressure, adjust the air atomizing restrictor valve. If atomization is inadequate, increase the air pressure.



t1282a

- Adjust the fan air adjustment valve: clockwise for a rounder pattern, counterclockwise for a wider pattern.



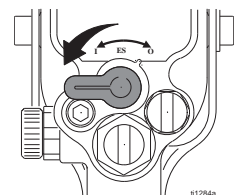
t1283a

## ! WARNING

**Electric Shock Hazard**

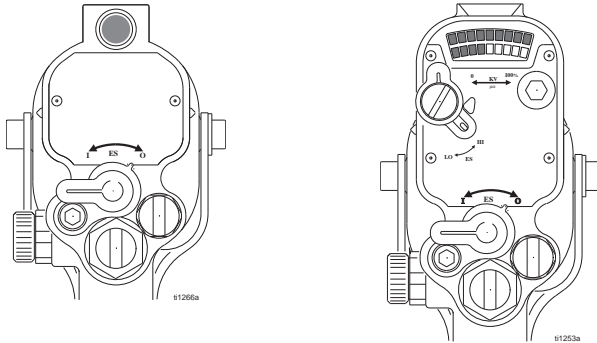
When the ES ON/OFF switch is turned ON, the fluid supply is charged with high voltage until the voltage is discharged. Contact with the charged components of the spray gun will cause an electric shock. Do not touch the gun nozzle or electrode or come within 4 in. (102 mm) of the front of the gun during operation.

- Turn the ES ON/OFF switch ON (I).

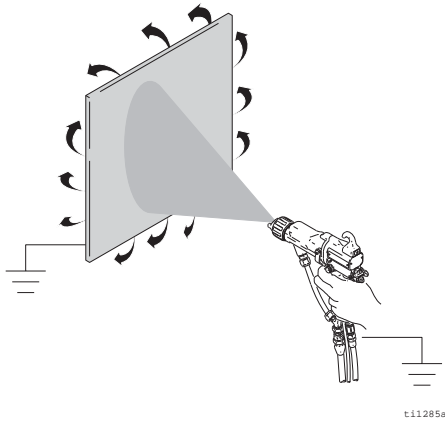


t1284a

13. Check that the ES indicator or display is lit, or check that the kV indicator on the isolated enclosure reads 45-55 kV. If not, see **Electrical Troubleshooting** on page 39 for possible problems.



14. Check the kV meter on the isolated enclosure; 45-55 kV is normal.
15. Spray a test piece. Examine the edges for coverage. If wrap is poor, see **Spray Pattern Troubleshooting** on page 37.

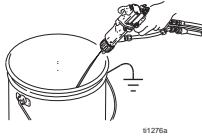


16. When you finish spraying, perform the **Shutdown** procedure on page 25.



## Shutdown

1. Discharge the system voltage (page 20).
2. Flush the spray gun. See page 26.

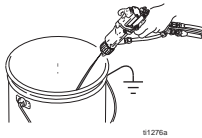


### ! WARNING

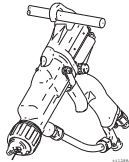
**Pressurized Equipment Hazard**

To reduce the risk of an injury, follow the **Pressure Relief Procedure** on whenever you are instructed to relieve the pressure.

3. Relieve the pressure (page 20).



4. Hang the gun from its hook or place it in the accessory holster, with the nozzle pointing down. Be sure to keep the gun from grounding out.



## Low Voltage Adjustment (Smart Guns Only)

The ES HI/LO switch enables you to switch between full voltage and a lower voltage output. The lower voltage is factory set, but can be adjusted.

1. Set the ES HI/LO switch to LO.

2. Remove the LO VOLTAGE adjustment plug (53). Set the desired voltage, using a small screwdriver to slide switches 1 and 2 ON or OFF, according to Table 4 . Also see FIG. 16..

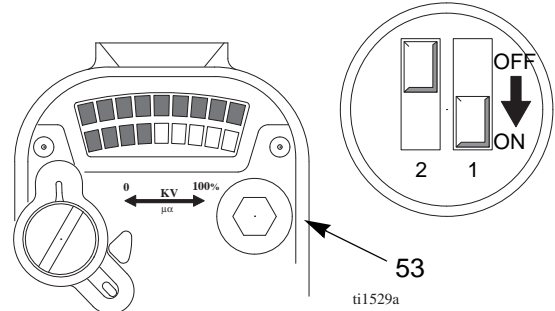


Fig. 16. Low Voltage Adjustment Switches

Table 4: Low Voltage Adjustment

	1	2	kV
	ON	ON	50
Factory Setting >	ON	OFF	40
	OFF	ON	35
	OFF	OFF	30


# Maintenance

## Flush the Spray Gun


Flush the gun before changing colors, at the end of the day, before storing, and before repairing the gun.

### ⚠ WARNING

**Fire, Explosion, and Electric Shock Hazard**



To reduce the risk of fire, explosion, or electric shock, turn the ES ON/OFF valve OFF before flushing the gun.




Follow the **Fluid Voltage Discharge and Grounding Procedure** on page 20 before flushing.

Only flush, purge, or clean the gun with fluids that meet at least one of the following conditions for non-flammability:

- The fluid has a flash point above 140°F (60°C) and a maximum organic solvent concentration of 20%, by weight, per ASTM Standard D93.
- The fluid does not sustain burning when tested per ASTM Standard D4206 Sustained Burn Test.

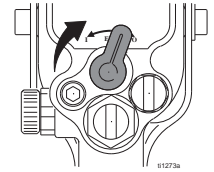
### ⚠ WARNING

**Pressurized Equipment Hazard**

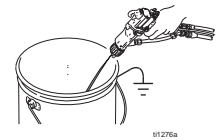


To reduce the risk of an injury, follow the **Pressure Relief Procedure** on page 20 whenever you are instructed to relieve the pressure.

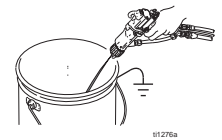
1. Turn the ES ON/OFF valve OFF and wait 30 seconds for the voltage to bleed off.



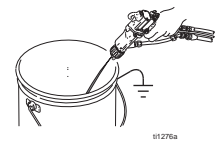
2. Discharge the system voltage (page 20).
3. Relieve the pressure (page 20).



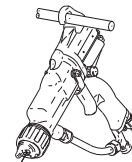
4. Change the fluid source to solvent.
5. Point the gun into a grounded metal pail. Flush until clean solvent flows from the gun.



6. Relieve the pressure.



7. Open the isolated enclosure door. Leave the flushing fluid in the system until you are ready to spray again.
8. Hang the gun from its hook, with the nozzle pointing down. Be sure to keep the gun from grounding out.



9. Before using the system electrostatically again, make sure no flammable vapors are present.

## Daily Care and Cleaning

### CAUTION

- Clean the outside of the gun daily with a soft cloth dampened with a non-flammable solvent, as defined on page 26.
- Check for fluid leaks. Tighten all fittings.
- Clean the air cap and fluid nozzle daily, minimum. See page 29. Some applications require more frequent cleaning.
- Fluid in the air passages could cause the gun to malfunction and could draw current and reduce the electrostatic effect. Fluid in the power supply cavity can reduce the alternator life. Do not use any cleaning method which could allow fluid into the gun air passages.
- Hang the gun with its nozzle pointing down when it is not being used.
- Clean the workpiece hangers with non-sparking tools.
- Clean the fluid and air line filters daily.
- Check the movement of the trigger and valves. Lubricate if necessary.

*Do not immerse the gun in fluid.*



ti1294a

*Do not point the gun up while cleaning it.*



ti1295a

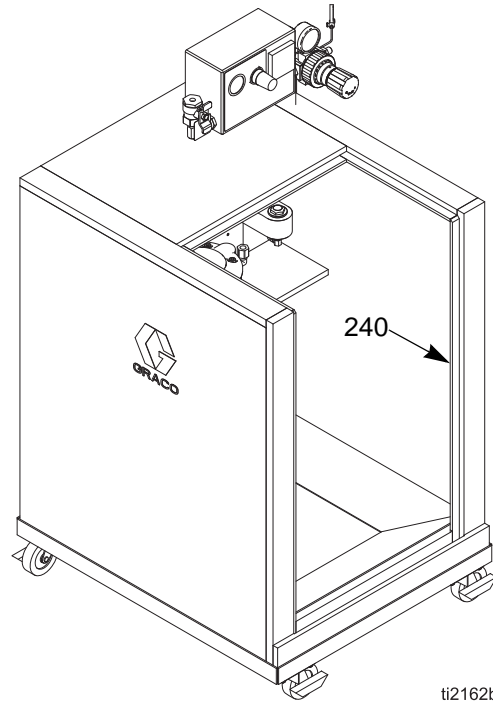
*Do not wipe the gun with a cloth that is heavily saturated; wring out the excess fluid.*



ti1293a

## CAUTION

- Inspect the cabinet and clean up any spilled paint. Conductive paint residue allowed to contact grounded parts may short out the electrostatics.
- Keep the inside of the cabinet clean, for proper operation.
- Visually inspect the ground strip (240) for damage. Replace if needed. Measure the resistance weekly. See page 33.



ti2162b

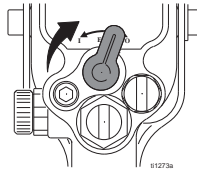
## Clean the Air Cap and Fluid Nozzle

### Equipment Needed

- soft bristle brush
- non-flammable solvent

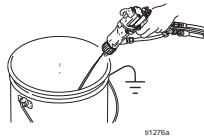
### Procedure

1. Turn the ES ON/OFF valve OFF. Wait 30 seconds.



2. Discharge the system voltage (page 20).

3. Relieve the pressure (page 20).



4. Remove the retaining ring (27) and air cap (9). See FIG. 17..

**NOTE:** If it appears that there is paint inside the fluid nozzle (7) air passages, remove the gun from the line for servicing.

7. Carefully install the air cap (9). Be sure to insert the electrode (29) through the center hole of the air cap. Rotate the air cap to the desired position.
8. Tighten the retaining ring (27) until the air cap is held firmly in place; you should not be able to rotate the air cap horns by hand.
9. Test gun resistance, page 30.

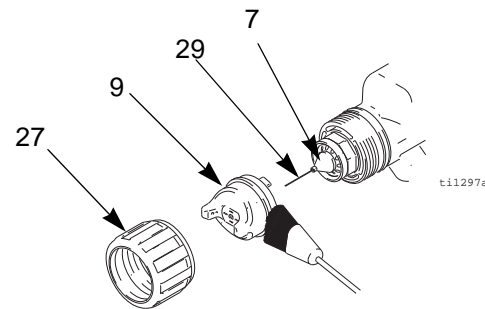


Fig. 17. Clean Air Cap and Fluid Nozzle

## Grease Door Latch Threads

Inspect the door T-handle locking screw regularly, to ensure the threads are well greased. Apply silicone-free grease to the threads when necessary.

### CAUTION



Do not use metal tools to clean the air cap or fluid nozzle holes as this could scratch them, and make sure the electrode is not damaged. Scratches in the air cap or nozzle or a damaged electrode can distort the spray pattern.

5. Clean the air cap (9) with the soft bristle brush and non-flammable solvent or submerge the air cap in solvent and wipe it clean.
6. With the gun pointing down, clean the fluid nozzle (7) and the front of the gun with a soft brush dampened with non-flammable solvent.


# Electrical Tests

Electrical components inside the gun affect performance and safety. The following procedures test the condition of the power supply (18) and electrode (29), and electrical continuity between components.

Use megohmmeter Part No. 241079 (AA) and an applied voltage of 500 V. Connect the leads as shown.

## ⚠ WARNING

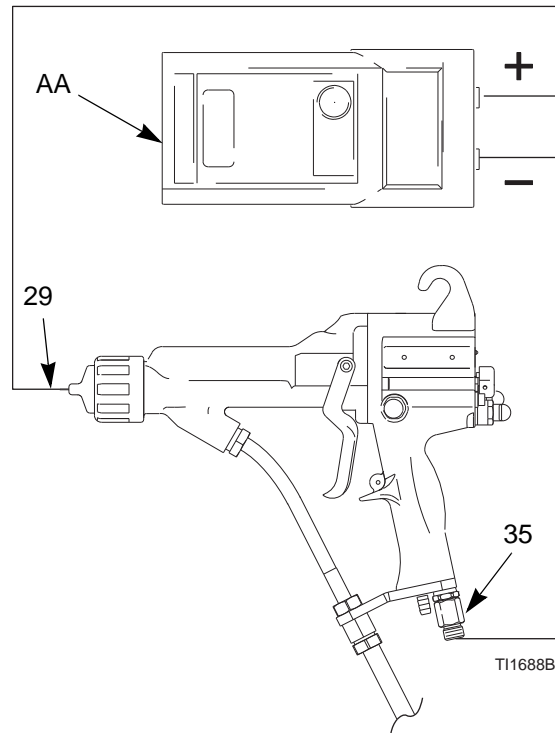
**Fire, Explosion, and Electric Shock Hazard**



Megohmmeter Part No. 241079 (AA-see FIG. 18.) is not approved for use in a hazardous area. To reduce the risk of sparking, do not use the megohmmeter to check electrical grounding unless:

- The gun has been removed from the hazardous area;
- Or all spraying devices in the hazardous area are turned off, ventilation fans in the hazardous area are operating, and there are no flammable vapors in the area (such as open solvent containers or fumes from spraying).

Failure to follow this warning could cause fire, explosion, and electric shock and result in serious injury and property damage.



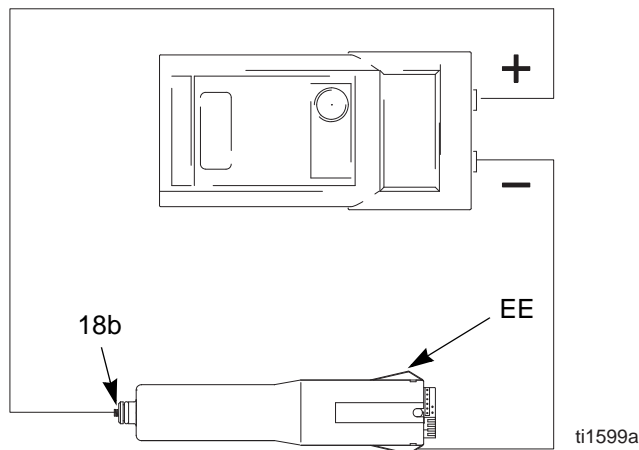
**Fig. 18. Test Gun Resistance**

## Test Gun Resistance

1. Prepare the gun for service as instructed on page 41.
2. Measure resistance between the electrode needle tip (29) and the air swivel (35); it should be 117-137 megohms. If outside this range, go to the next test. If you still have problems, refer to **Voltage Loss Troubleshooting** on page 34 for other possible causes of poor performance, or contact your Graco distributor.

## Test Power Supply Resistance

1. Prepare the gun for service as instructed on page 41.
2. Remove the power supply (18), page 46.
3. Remove the turbine alternator (19) from the power supply, page 47.
4. Measure resistance from the power supply's ground strips (EE) to the spring (18b). See FIG. 19..
5. The resistance should be 95-105 megohms. If outside this range, replace the power supply. If in range, proceed to the next test.
6. Be sure the spring (18b) is in place before reinstalling the power supply.



**Fig. 19. Test Power Supply Resistance**

## Test Electrode Resistance

1. Prepare the gun for service as instructed on page 41.
2. Insert a conductive rod (B) into the gun barrel (removed for the power supply test) and against the metal contact (C) in the front of the barrel.
3. Measure the resistance between the conductive rod (B) and the electrode (29). The resistance should be 20-30 megohms. See FIG. 20..
4. If in range, refer to **Electrical Troubleshooting** on page 39 for other possible causes of poor performance, or contact your Graco distributor.
5. Remove the electrode (29), page 43. Measure the resistance between the contact (E) and the electrode wire (F). The resistance should be 20-30 megohms. If out of range, replace the electrode. See FIG. 21..
6. Make sure the metal contact (C) in the barrel, the nozzle contact ring (7a, FIG. 22.), and the electrode contact (E) are clean and undamaged.

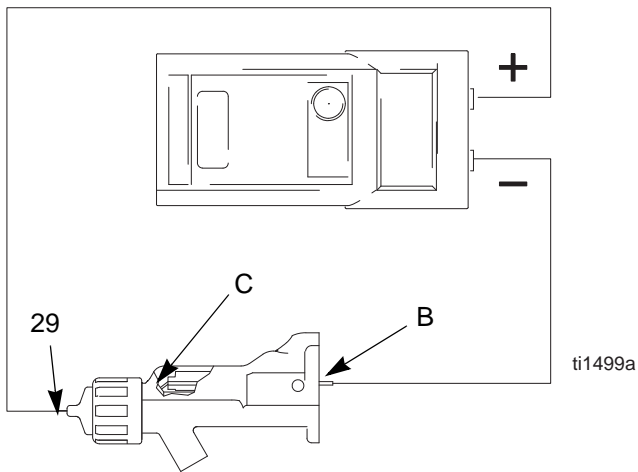


Fig. 20. Test Electrode Resistance

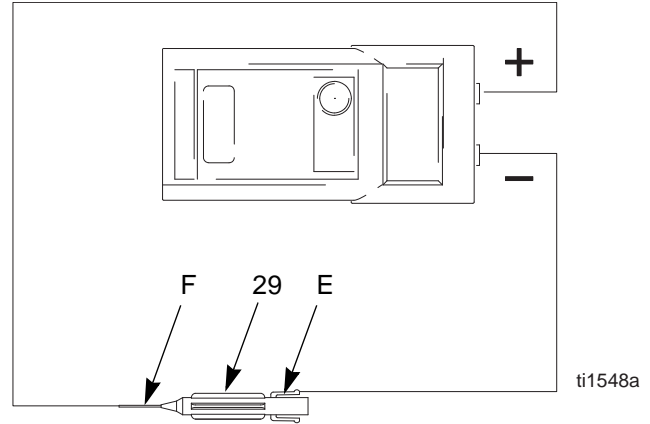


Fig. 21. Electrode

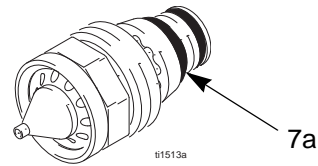
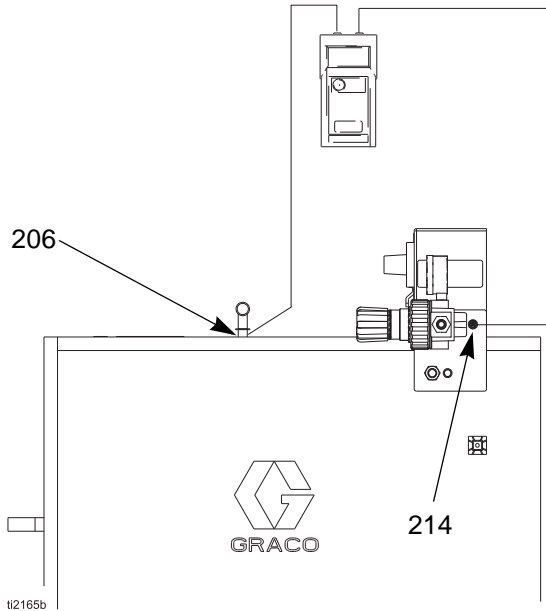


Fig. 22. Nozzle Conductive O-Ring



## Test Ground Strip Resistance

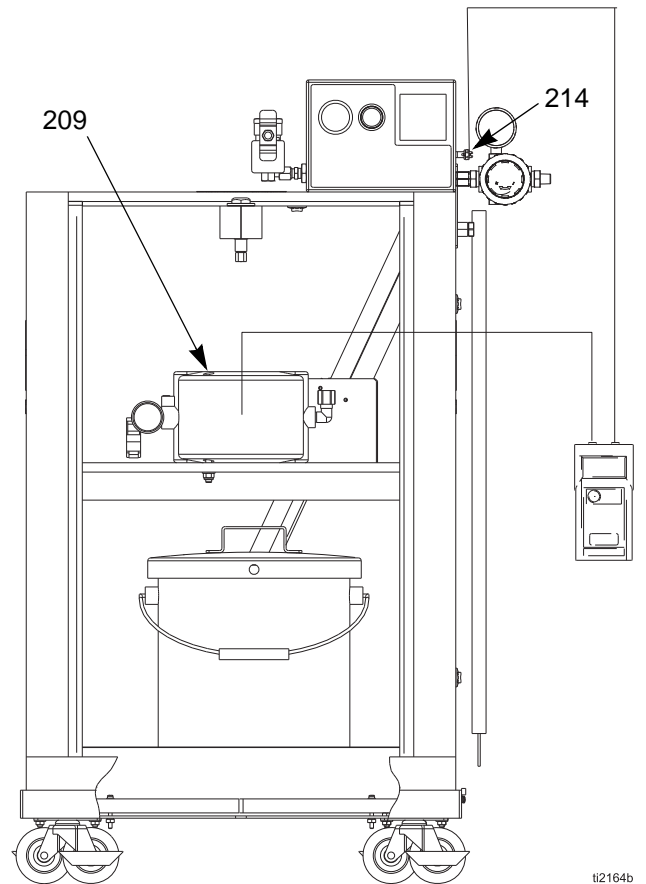
See FIG. 23.. Using an ohmmeter, measure the resistance between the latch housing (206) and the ground lug (214). The ground strip is grounded through the cart back to the ground lug. Resistance must be less than 100 ohms. If greater than 100 ohms, replace the ground strip (240).



**Fig. 23. Test Ground Strip Resistance**

## Test Cylinder Resistance

See FIG. 24.. Remove the enclosure door. Using an ohmmeter, measure the resistance from the pump (209) to the ground lug (214). Resistance must be less than 100 ohms. If greater than 100 ohms, replace the grounding cylinder.



**Fig. 24. Test Cylinder Resistance**

# Troubleshooting

## WARNING

### Electric Shock Hazard



Installing and servicing this equipment requires access to parts which may cause an electric shock or other serious injury if the work is not performed properly. Do not install or repair this equipment unless you are trained and qualified.

Follow the **Fluid Voltage Discharge and Grounding Procedure** on page 20 before checking or servicing the system and whenever you are instructed to discharge the voltage.

## WARNING

### Pressurized Equipment Hazard



To reduce the risk of an injury, follow the **Pressure Relief Procedure** on page 20 before checking or servicing any part of the system and whenever you are instructed to relieve the pressure.

## Voltage Loss Troubleshooting

Normal spraying voltage for a system using the waterborne gun is 45-55 kV. The system voltage is lower due to spraying current demands and voltage isolation system losses.

A loss of spraying voltage can be caused by a problem with the spray gun, fluid hose, or voltage isolation system, since all of the system components are electrically connected through the conductive, waterborne fluid.

Before troubleshooting or servicing the voltage isolation system itself, you need to determine which component in the system is most likely causing a problem. Possible causes include the following:

### Spray Gun

- Fluid leakage
- Dielectric breakdown at the fluid hose connection or fluid packings
- Not enough air pressure for the turbine
- Faulty power supply
- Excessive overspray on gun surfaces
- Fluid in the air passages

### Waterborne Fluid Hose

- Dielectric failure of hose (pin-hole leak through PTFE layer)
- Air gap in the fluid column between the gun and isolated fluid supply, causing a low voltage reading on the isolation system voltage meter.

### Voltage Isolation System

- Fluid leakage
- Dirty interior

## Visual Check

First, check the system for any visible faults or errors to help isolate whether the spray gun, fluid hose or voltage isolation system has failed. A voltage probe and meter, part no. 236003, is helpful for diagnosing voltage problems and is required for some of the troubleshooting tests that follow.

1. Check that all of the air and fluid tubes and hoses are properly connected.
2. Check that the voltage isolation system valves and controls are properly set for operation.
3. Check that the interior of the isolated enclosure is clean.
4. Check that the spray gun and voltage isolation system have sufficient air pressure.
5. Check that the gun ES ON/OFF valve is in the ON position and that the gun ES indicator light is on. If the ES indicator light is not on, remove the spray gun for service and complete the electrical tests on pages 30- 32.
6. Check that the voltage isolation system's enclosure door is closed and that any safety interlocks are engaged and working properly.
7. Make sure the voltage isolation system is in the "isolate" mode, where it is isolating the fluid voltage from ground.
8. To eliminate air gaps in the fluid column, spray enough fluid to purge the air out between the voltage isolation system and the spray gun. An air gap in the fluid hose can break the electrical continuity between the spray gun and the isolated fluid supply and cause a low voltage reading on a voltage meter connected to the isolated fluid supply.
9. Check the spray gun cover and barrel for accumulated overspray. Excessive overspray can create a conductive path back to the grounded gun handle. Install a new gun cover and clean the exterior of the gun.

10. Inspect the entire system for any visible fluid leakage and repair any fluid leaks that are found. Pay special attention to the following areas:
  - Packing area of the spray gun
  - Fluid hose: check for leakage or any bulges in the outer cover, which may indicate an internal leak
  - Internal voltage isolation system components

## Tests

If you still have no voltage, separate the spray gun and hose from the voltage isolation system and check whether the gun and hose alone will hold voltage with the following test.

1. Flush the system with water and leave the lines filled with water.
2. Discharge the system voltage (page 20).
3. Relieve the pressure (page 20).
4. Disconnect the fluid hose from the voltage isolation system.

**NOTE:** Avoid allowing any water to leak out of the fluid hose as that could cause a significant air gap in the fluid column up to the gun electrode, which can break the conductivity path and conceal a potential failure area.

5. Position the end of the hose as far as possible away from any grounded surface. The end of the hose must be at least 1 ft. (0.3 m) from any ground. Make sure that no one is within 3 ft. (0.9 m) of the end of the hose.
6. Turn the ES ON/OFF valve to ON and trigger the gun just enough to turn on the air to the gun but not the fluid. Measure the voltage at the gun electrode with a voltage probe and meter.
7. Discharge the system voltage by waiting 30 seconds and then touching the gun electrode with a grounded rod.
8. If the meter reading is 45 to 55 kV, the gun and fluid hose are okay, and the problem is in the voltage isolation system.

If the reading is below 45 kV, the problem is in the gun or fluid hose.

9. Flush the fluid hose and gun with enough air to dry out the fluid passages.
10. Turn the ES ON/OFF valve to ON and trigger the gun. Measure the voltage at the gun electrode with a voltage probe and meter.
11. If the meter reading is 45-55 kV, the gun power supply is okay, and there is probably a dielectric breakdown somewhere in the fluid hose or gun. Continue with step 12.
12. A dielectric breakdown is most likely in one of the following three areas. Repair or replace the component that is failing.
  - Fluid hose
13. Before reassembling the gun, clean and dry the gun fluid inlet tube. Repack the inner spacer of the fluid packing rod with dielectric grease and reassemble the gun.
14. Reconnect the fluid hose.
15. Check the gun voltage with the voltage probe and meter before filling the gun with fluid.

If the reading is below 45 kV, do the electrical tests on page 30 to check the gun and power supply resistance. If those tests show the gun and power supply are okay, continue with step 12.

- Fluid hose

Check for leakage or any bulges in the outer cover, which may indicate a pin-hole leak through the PTFE layer. Disconnect the fluid hose from the gun, and look for signs of fluid contamination on the outside of the PTFE portion of the fluid tube.

Inspect the end of the hose connected to the voltage isolation system. Look for cuts or nicks.

Make sure the hose is properly stripped (see step 2 on page 12). Restrip or replace the hose.

- Fluid packings

Remove the packing assembly from the gun as instructed on page 44, and look for signs of fluid leakage or any blackened areas, which would indicate arcing is occurring along the packing rod.

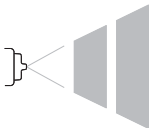




- Fluid hose connection joint to the spray gun

A breakdown at the fluid hose connection joint would be caused by fluid leaking past the o-ring seals on the end of the hose. Remove the hose at the gun connection and look for signs of fluid leakage along the PTFE tube.

## Spray Pattern Troubleshooting

**NOTE:** Check all possible remedies in the Troubleshooting Chart before disassembling the gun.

**NOTE:** Some spray pattern problems are caused by the improper balance between air and fluid.

Problem	Cause	Solution
Fluttering or spitting spray. 	No fluid.	Refill supply.
	Loose, dirty, damaged nozzle/seat.	Clean or replace nozzle, page 42.
	Air in fluid supply.	Check fluid source. Refill.
Improper spray pattern. 	Damaged nozzle or air cap.	Replace, page 42.
	Fluid buildup on air cap or nozzle.	Clean. See page 29.
	Fan air pressure too high.	Decrease.
	Fluid too thin.	Increase viscosity.
	Fluid pressure too low.	Increase.
	Fan air pressure too low.	Increase.
	Fluid too thick.	Reduce viscosity.
	Too much fluid.	Decrease flow.
Streaks.	Did not apply 50% overlap.	Overlap strokes 50%.
	Dirty or damaged air cap.	Clean or replace, page 42.

## Gun Operation Troubleshooting

Problem	Cause	Solution
Excessive spray fog.	Atomizing air pressure too high.	Close restrictor valve some, or decrease air pressure as low as possible; minimum 40 psi (0.28 MPa, 2.8 bar) needed at gun for full voltage.
	Fluid too thin.	Increase viscosity.
"Orange Peel" finish.	Atomizing air pressure too low.	Open atomizing air valve more or increase gun air inlet pressure; use lowest air pressure necessary.
	Poorly mixed or filtered fluid.	Remix or refill fluid.
	Fluid too thick.	Reduce viscosity.
Fluid leaks from the fluid packing area	Worn packings or rod.	Replace packings or rod; see page 45.
Air leaks from the front of the gun	Air valve (21) is not seating properly.	Clean and service air valve; see page 50.
Fluid leakage from the front of the gun	Worn or damaged packing rod (26).	Replace; see page 45
	Worn fluid seat.	Replace fluid nozzle and/or electrode needle; see pages 42 to 43.
	Loose fluid nozzle (7).	Tighten; see page 42.
	Damaged nozzle o-ring (7b).	Replace; see page 42.
Gun does not spray	Low fluid supply.	Add fluid if necessary.
	Damaged air cap (9).	Replace; see page 42.
	Dirty or clogged fluid nozzle (7).	Clean; see page 42.
	Damaged fluid nozzle (7).	Replace; see page 42.
	Damaged fluid adjustment valve (25).	Replace; see page 50.
Dirty air cap	Misaligned air cap (9) and fluid nozzle (7).	Clean fluid buildup off air cap and fluid nozzle seat; see page 29.

## Electrical Troubleshooting

Problem	Cause	Solution
Voltage still present at gun after following the <b>Fluid Voltage Discharge and Grounding Procedure</b>	ES ON/OFF valve is not turned OFF.	Turn OFF.
	Did not wait long enough for voltage to discharge.	Wait longer before touching electrode with grounded rod. Check for bleed resistor failure.
	Air pocket in fluid line leaves fluid near gun isolated.	Determine cause and correct. Purge air from fluid line.
	Voltage isolation system failed.	Service voltage isolation system.
	Grounding cylinder not operating.	Check resistance of grounding cylinder, page 33. Replace if needed.
Poor wrap.	ES ON/OFF valve OFF (0).*	Turn ON (I).
	Gun air pressure too low.	Check air pressure to gun; minimum 40 psi (0.28 MPa, 2.8 bar) needed at gun for full voltage.
	Atomizing air pressure too high.	Decrease.
	Fluid pressure too high.	Decrease.
	Incorrect distance from gun to part.	Should be 8-12 in. (200-300 mm).
	Poorly grounded parts.	Resistance must be 1 megohm or less. Clean workpiece hangers.
	Faulty gun resistance.	See <b>Test Gun Resistance</b> on page 30.
	Fluid leaks from the packing (26d) and causes a short.	Clean the packing rod cavity. Replace the packing rod. See page 45.
	Faulty turbine alternator.	Be sure the plug is in place on the back of the turbine alternator housing. Remove and test the turbine alternator. See page 48.
	The KV HI-LO lever is on LO.	Check the lever actuation; replace if needed.
Spilled paint, dried paint, or other contaminants inside WB100 enclosure, causing a short circuit.	Clean interior of enclosure.	

Problem	Cause	Solution
ES indicator or voltage/current display is not lit.	ES ON/OFF valve OFF (0).*	Turn ON (I).
	No power.	Replace power supply. See page 47.
Voltage/current display stays red (smart guns only).	Gun too close to part.	Should be 8-12 in. (200-300 mm).
	Check fluid resistivity.	See <b>Operation</b> on page 19.
	Dirty gun.	Clean. See page 27.
Operator gets mild shock.	Operator not grounded or is near ungrounded object.	See <b>Grounding</b> on page 17.
	Gun not grounded.	See <b>Check Electrical Grounding</b> on page 18 and <b>Test Gun Resistance</b> on page 30.
	A weak static charge has built up on the surface of an unshielded fluid hose. This is a charge on the hose surface, not a failure of the hose insulation.	Bundle and wrap the air and fluid hoses together. See <b>Connect the Waterborne Fluid Hose</b> , page 11.
Operator gets shock from workpiece.	Workpiece not grounded.	Resistance must be 1 megohm or less. Clean workpiece hangers.

\* ES indicator light is off when the gun is triggered.



# Repair

## Prepare the Gun for Service

### WARNING

#### Fire, Explosion, and Electric Shock Hazard



To reduce the risk of a fire, explosion, or electric shock:



- Follow the **Fluid Voltage Discharge and Grounding Procedure** on page 20 and be sure the ES ON/OFF valve is OFF before flushing, checking, or servicing the system and whenever you are instructed to discharge the voltage.

- Clean all parts with a non-flammable fluid as defined on the front cover of this manual.

- Do not service this equipment unless you are trained and qualified.

- Do not touch the gun nozzle or come within 4 in. (102 mm) of the nozzle during gun operation or until you perform the **Fluid Voltage Discharge and Grounding Procedure** on page 20.

### WARNING

#### Pressurized Equipment Hazard



To reduce the risk of injury, follow the **Pressure Relief Procedure** on page 20 before checking or servicing any part of the system and whenever you are instructed to relieve the pressure.

- Check all possible remedies in **Troubleshooting** before disassembling the gun.
  - Use a vise with padded jaws to prevent damage to plastic parts.
  - Lubricate the power supply o-ring (18a), some packing rod parts (26), and certain fluid fittings with dielectric grease (40), as specified in the text.
  - Lightly lubricate o-rings and seals with non-silicone grease. Order Part No. 111265 Lubricant. Do not over-lubricate.
  - Only use genuine Graco parts. Do not mix or use parts from other PRO Gun models.
  - Air Seal Repair Kit 244781 is available. The kit must be purchased separately. Kit parts are marked with an asterisk, for example (6\*).
  - Fluid Seal Repair Kit 244911 is available. The kit must be purchased separately. Kit parts are marked with a double asterisk, for example (26a\*\*).
1. Follow the **Fluid Voltage Discharge and Grounding Procedure** on page 20.
  2. Flush the gun, page 26.
  3. Blow the fluid lines dry with air.
  4. Relieve the pressure, page 20.
  5. Disconnect the gun air and fluid lines at the isolation system.
  6. Remove the gun from the worksite. Repair area must be clean.

#### NOTE:

## Air Cap/Nozzle Replacement

### CAUTION

Hold the front end of the gun up and trigger the gun while removing the nozzle to help drain the gun and prevent any paint or solvent left in the gun from entering the air passages.

1. Prepare gun for service, page 41.
2. Remove the retaining ring (27) and air cap (9). See FIG. 25..
3. Point gun up and squeeze trigger while removing the fluid nozzle (7) assembly with the multi-tool (37).

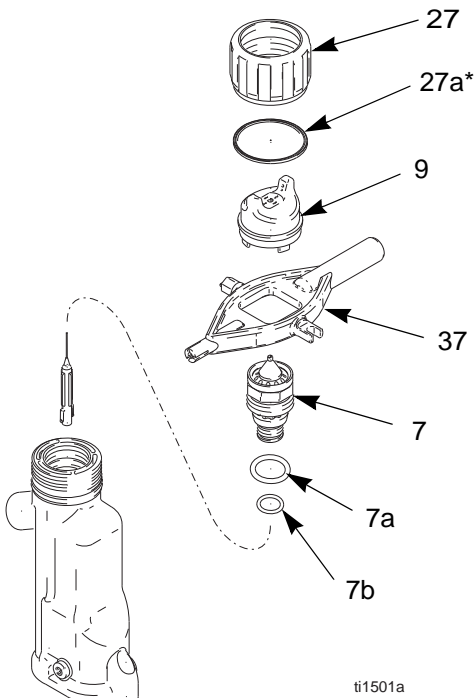


Fig. 25. Air Cap/Nozzle Replacement

### WARNING

#### Fire, Explosion, and Electric Shock Hazard



The nozzle contact ring (7a) is a conductive contact ring, not a sealing o-ring. To reduce the risk of sparking or electric shock, do not remove the nozzle contact ring (7a) except to replace it and never operate the gun without the contact ring in place. Do not replace the contact ring with anything but a genuine Graco part.

**NOTE:** Use non-silicone grease, Part No. 111265, on the small o-ring (7b). Do not over-lubricate. Do not lubricate the contact ring (7a).

4. Lightly lubricate the o-ring (7b). Install it and the contact ring (7a) on the nozzle (7).

**NOTE:** Make sure the electrode needle (29) is finger-tight (page 43).

5. Trigger gun while installing the fluid nozzle (7) with the multi-tool (37). Tighten until the fluid nozzle seats in the gun barrel (1/8 to 1/4 turn past hand-tight).
6. Install the air cap (9) and retaining ring (27). Make sure the u-cup (27a\*) is in place with the lips facing forward.
7. Test gun resistance, page 30.

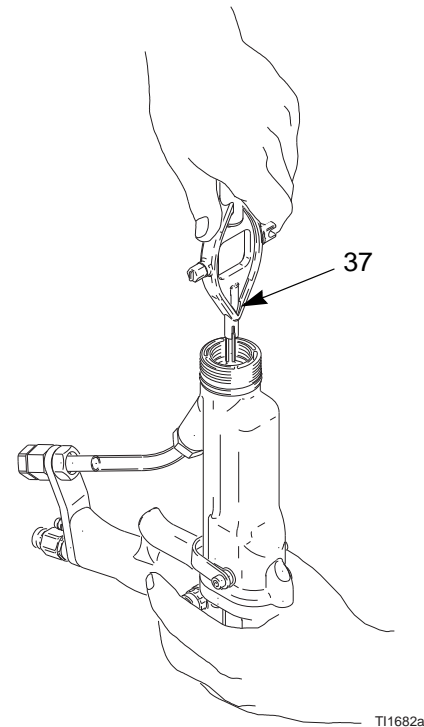
## Electrode Replacement

1. Prepare the gun for service, page 41.
2. Remove the air cap and nozzle, page 42.
3. Unscrew the electrode (29) with the multi-tool (37). Hold the packing rod end (26h) to prevent it from turning, FIG. 26..

### CAUTION

To avoid damaging the plastic threads, be very careful when installing the electrode.

4. Apply low-strength (purple) Loctite® or equivalent thread sealant to the electrode and packing rod threads. Install the electrode finger-tight. Do not overtighten.
5. Install the fluid nozzle and air cap, page 42.
6. Test gun resistance, page 30.



**Fig. 26. Electrode Replacement**

## Fluid Packing Removal

1. Prepare the gun for service, page 41.
2. Remove the air cap and fluid nozzle, page 42.
3. Remove the electrode, page 43.
4. Loosen the trigger screws (8) and trigger (30). See FIG. 27..
5. Remove the packing rod (26), using the multi-tool (37).

### CAUTION

Clean all parts in non-conductive solvent compatible with the fluid being used, such as xylol or mineral spirits. Use of conductive solvents can cause the gun to malfunction.

6. Check all parts for wear or damage and replace if necessary.

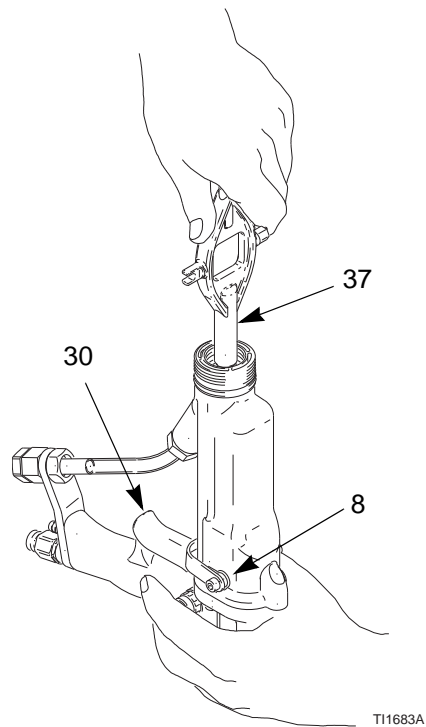


Fig. 27. Fluid Packing Removal

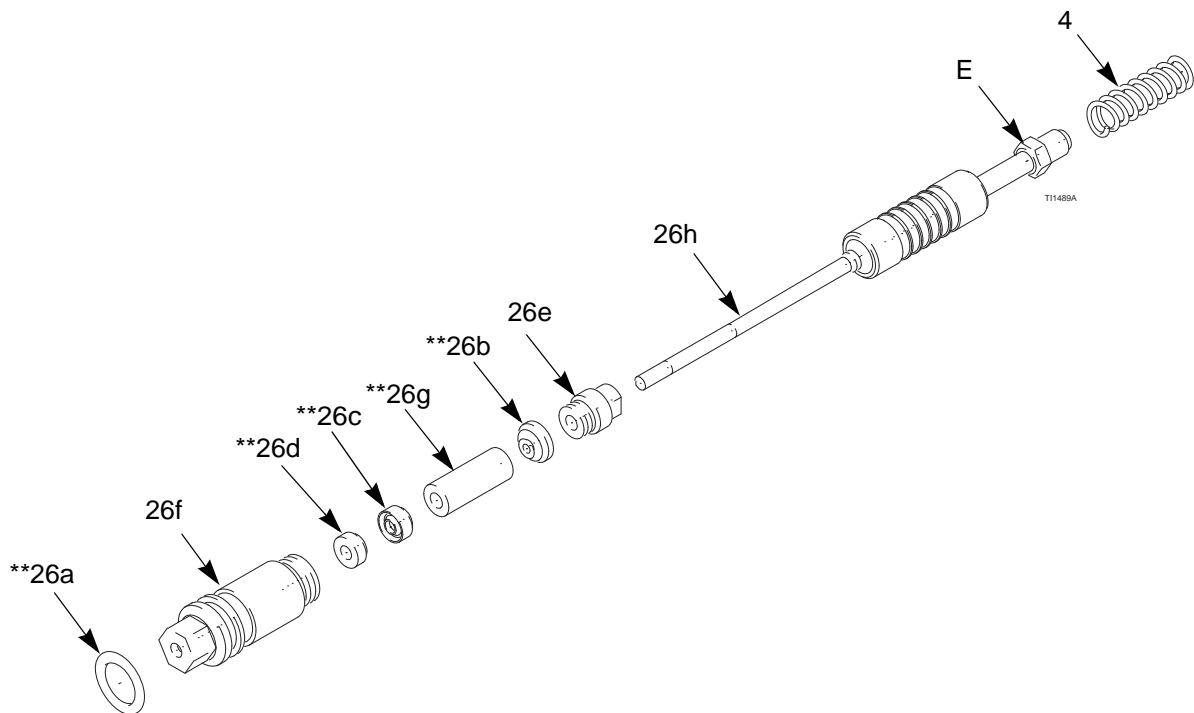
## Packing Rod Repair

You may replace the packing rod as individual parts or as an assembly. The assembly is pre-adjusted at the factory.

**NOTE:** Before installing the fluid packing rod into the gun barrel, make sure the internal surfaces of the barrel are clean. Remove any residue with a soft brush or cloth. Check the inside of the barrel for marks from high voltage arcing. If marks are present, replace the barrel.

To assemble the individual parts:

1. Place the packing nut (26e) and seal (26b\*\*) on the fluid rod (26h). Flats on the packing nut must face the back of the fluid rod. The seal o-ring must face away from the packing nut. See FIG. 28..
2. Fill the inner cavity of the spacer (26g\*\*) with dielectric grease (40). Place the spacer on the fluid rod (26h) in the direction shown. Generously apply dielectric grease to the outside of the spacer.
3. Place the packing spreader (26c\*\*), rod packing (26d\*\*), and housing (26f) on the packing rod (26h).
4. Lightly tighten the packing nut (26e). The packing nut is properly tightened when there is 3 lb (13.3 N) of drag force when sliding the packing housing (26f) assembly along the rod. Tighten or loosen the packing nut as needed.
5. Install the o-ring (26a\*\*) on the outside of housing (26f). Lubricate the o-ring with non-silicone grease, Part No. 111265. Do not over-lubricate.
6. Install the spring (4) against the nut (E) as shown.
7. Install the packing rod assembly (26) into the gun barrel. Using the multi-tool (37), tighten the assembly until just snug.
8. Install the trigger (30) and screws (8).
9. Install the electrode, page 43.
10. Install the nozzle and air cap, page 42.
11. Test gun resistance, page 30.



**Fig. 28. Packing Rod**

## Barrel Removal

1. Prepare the gun for service, page 41.
2. Remove the air inlet fitting (35) and take the bracket (104) off the gun handle (17).
3. Loosen the three screws (11).

### CAUTION

To avoid damaging the power supply (18), pull the gun barrel straight away from the gun handle. If necessary, gently move the gun barrel from side to side to free it from the gun handle.

4. Hold the gun handle (17) with one hand and pull the barrel (16) straight off the handle. See FIG. 29..

## Barrel Installation

1. Be sure the gasket (10\*) and grounding spring (55) are in place. Make sure the gasket air holes are aligned properly. Replace if damaged. See FIG. 30..
2. Place the barrel (16) over the power supply (18) and onto the gun handle (17).
3. Tighten the three screws (11) oppositely and evenly (about a half turn past snug).

### CAUTION

Do not over-tighten the screws (11).

4. Position the bracket (104) on the gun handle (17) and secure with the air inlet fitting (35).
5. Apply dielectric grease (40) to the exposed inner tube of the fluid hose (101).
6. Check that the nut (105) is tight on the ferrule housing (103).

7. Test gun resistance, page 30.

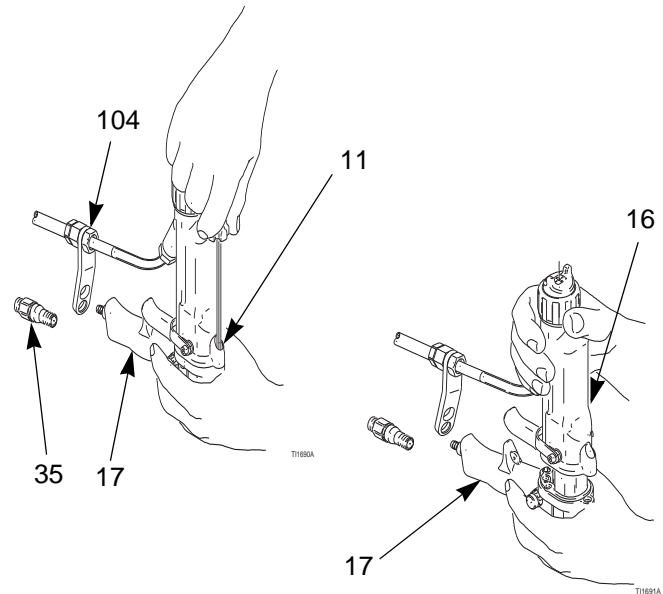


Fig. 29. Barrel Removal

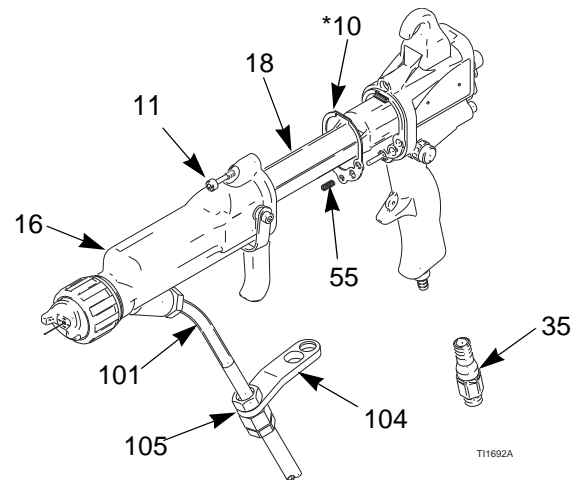


Fig. 30. Barrel Installation

## Power Supply Removal and Replacement

### NOTE:

- Inspect the gun handle power supply cavity for dirt or moisture. Clean with a clean, dry rag.
- Do not expose gasket (10) to solvents.

1. Prepare gun for service, page 41.
2. Remove the barrel (16), page 46.

### CAUTION

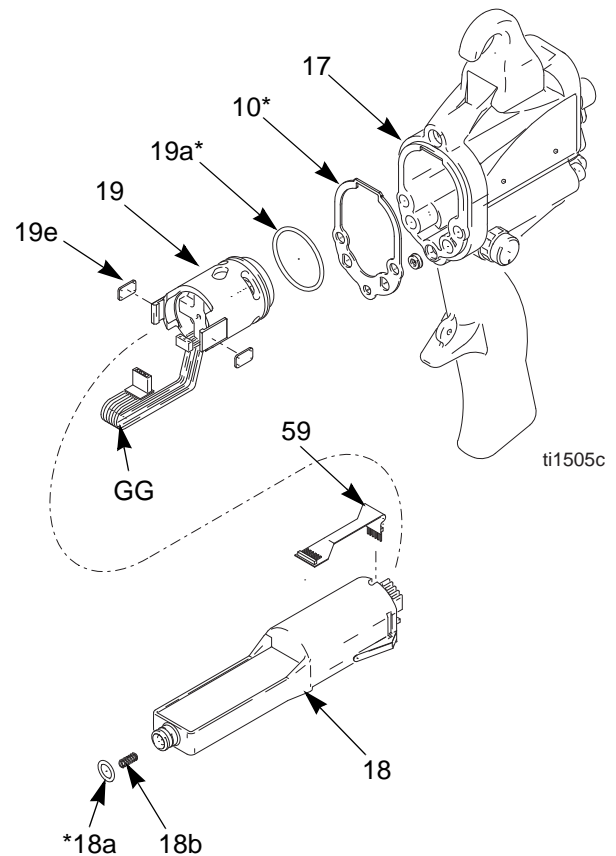
Be careful when handling the power supply (18) to avoid damaging it.

3. Grasp the power supply (18) with your hand. With a gentle side to side motion, free the power supply/alternator assembly from the gun handle (17), then carefully pull it straight out. *On Smart Models only*, disconnect the flexible circuit (59) from the socket at the top of the handle (17). See FIG. 31..
4. Disconnect the 3-wire connector (GG) from the power supply. Slide the alternator up and off the power supply. Inspect the power supply and alternator for damage. *On Smart Models only*, disconnect the 6-pin flexible circuit (59) from the power supply.
5. Check the power supply resistance, page 31. Replace if necessary.

**NOTE:** Before installing the power supply, make sure the o-rings (18a\*, 19a\*), spring (18b), and pads (19e) are in place.

6. *On Smart Models only*, connect the 6-pin flexible circuit (59) to the power supply.
7. Connect the 3-wire connector (GG). Slide the alternator (19) down onto the power supply (18).
8. Lubricate the alternator o-ring (19a\*) with non-silicone grease, Part No. 111265. Do not over-lubricate.

9. Lubricate the power supply o-ring (18a\*) with dielectric grease (40).
10. Insert the power supply/alternator assembly in the gun handle (17). Make sure the ground strips make contact with the handle. *On Smart Models only*, connect the flexible circuit (59) to the socket at the top of the handle. Push the 6-pin connector into the socket to ensure it is properly connected.
11. Install the barrel (16), page 46.
12. Test gun resistance, page 30.



**Fig. 31. Power Supply**

## Turbine Alternator Removal and Replacement

**NOTE:** Replace turbine alternator bearings after 2000 hours of operation. Order Part No. 223688 Bearing Kit.

1. Prepare gun for service, page 41.
2. Remove the power supply/alternator assembly, page 47.
3. Disconnect the alternator from the power supply, page 47.
4. Measure resistance between the two outer terminals of the 3-wire connector (GG); it should be 2.5-3.5 ohms. If outside this range, replace the alternator coil.
5. Follow the bearing replacement procedure in the bearing kit manual 308034.
6. Install the alternator on the power supply, page 47.
7. Install the power supply/alternator assembly, page 47.



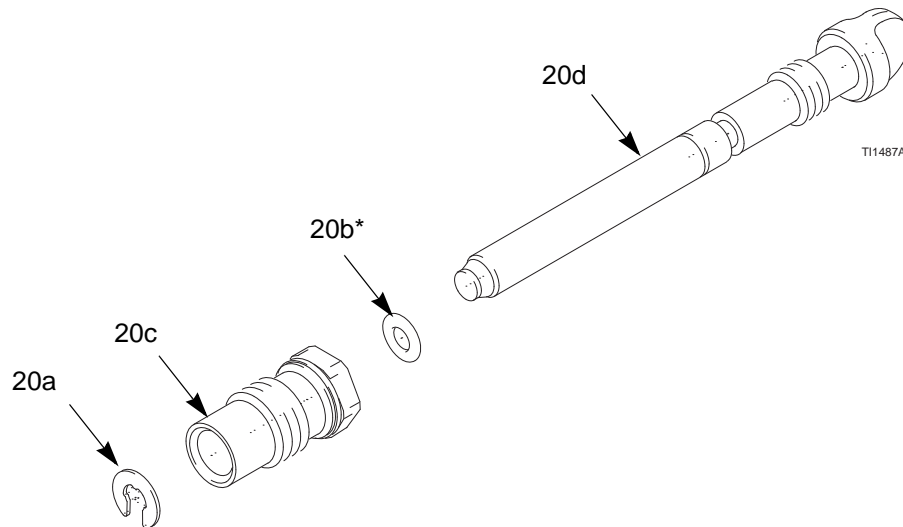
## Fan Air Adjustment Valve Repair

1. Prepare the gun for service, page 41.
  2. Place a wrench on the flats of the valve assembly (20) and unscrew it from the handle (17).
- NOTE:** You may replace the valve as an assembly (go to step 9) or as individual parts (steps 3-9).
3. Remove the retaining ring (20a). See FIG. 32..
  4. Turn the valve stem (20d) counterclockwise until it comes free from the valve housing (20c).
  5. Remove the o-ring (20b).

6. Clean all parts and inspect for wear or damage.

**NOTE:** Use non-silicone grease, Part No. 111265. Do not over-lubricate.

7. When reassembling the fan air valve (20), lightly lubricate the valve threads and screw the stem (20d) fully into the housing (20c) until bottomed. Install the o-ring (20b\*), lubricate, and unscrew the valve stem until the o-ring enters the housing.
8. Reassemble the retaining ring (20a). Unscrew the valve stem from the housing until it is stopped by the retaining ring.
9. Screw the valve assembly (20) into the gun handle, using a wrench on the flats of the housing. Torque to 15-25 in-lb (1.7-2.8 N•m).



**Fig. 32. Fan Air Adjustment Valve**

## Fluid Adjustment Valve Repair

1. Prepare the gun for service, page 41.
2. Remove the fluid adjustment valve (25). It can only be replaced as a complete assembly. See FIG. 33..
3. Screw the valve (25) into the gun handle. Torque to 15-25 in-lb (1.7-2.8 N•m).

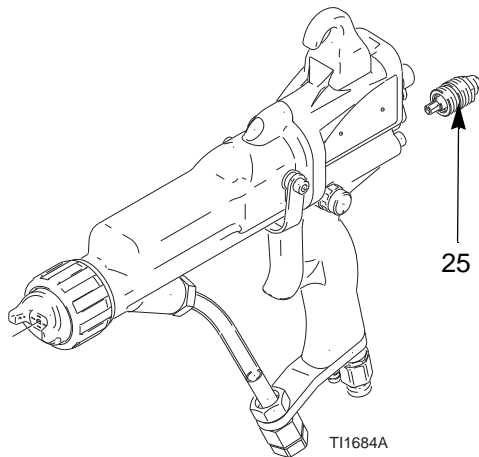




Fig. 33. Fluid Adjustment Valve

## Air Valve Repair

1. Prepare the gun for service, page 41.
2. Remove the barrel, page 46.
3. Remove the fluid adjustment valve (25) from the handle (17). Remove the spring (15). See FIG. 34..

 <b>CAUTION</b>
Clean all parts in non-conductive solvent compatible with the fluid being used, such as xylol or mineral spirits. Use of conductive solvents can cause the gun to malfunction.

4. Remove the air valve (21) with a pliers. Inspect the seal (21a\*) and replace if damaged. Be sure the seal is pressed securely onto the valve so the outer cone is flats.

 <b>CAUTION</b>
When removing the air valve (21) be careful not to damage the seat area.

5. Inspect the u-cup (6\*). Do not remove the u-cup unless damaged. If removed, install the new one with its lips facing into the gun handle (17).
6. Install the air valve (21) and spring (15) into the gun handle (17).
7. Install the fluid adjustment valve (25). Torque to 15-25 in-lb (1.7-2.8 N•m).
8. Install the barrel, page 46.

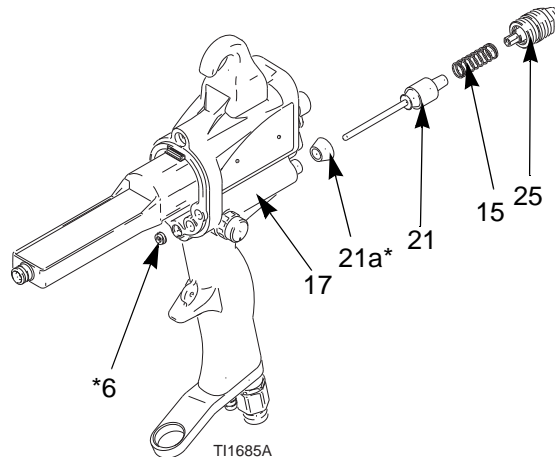


Fig. 34. Air Valve

## Atomizing Air Restrictor Valve Removal and Replacement

1. Prepare the gun for service, page 41.
  2. Remove the atomizing air restrictor valve (23). Inspect the o-ring (23c\*). Replace if necessary. See FIG. 35..
  3. Install a new atomizing air restrictor valve (23), or disassemble and replace parts individually. The valve protrusion must be oriented to clear the air valve (21) shaft.
- NOTE:** If the atomizing air restrictor valve is not desired, install the supplied plug (47).
4. Torque the valve housing (23a) to 15-20 in-lb (1.7-2.3 N•m).

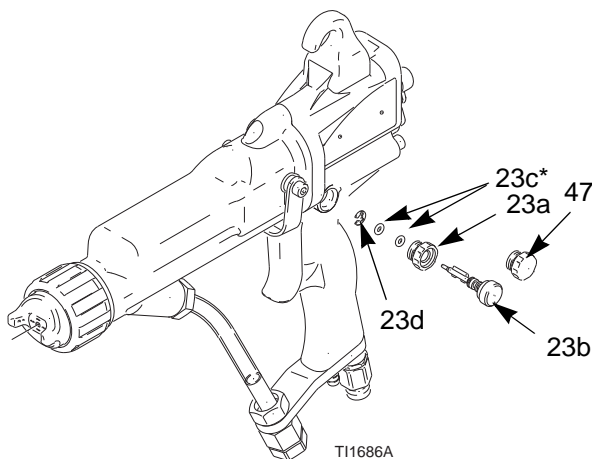


Fig. 35. Atomizing Air Restrictor Valve

## ES ON/OFF Valve Repair

1. Prepare the gun for service, page 41.
2. Loosen the screw (48). Remove the valve.
3. Lubricate the o-rings (22a\* and 22b\*) with non-silicone grease, Part No. 111265. Do not over-lubricate.

### CAUTION

Do not over-lubricate parts. Excessive lubricant on the o-rings can be pushed into the gun air passage and blemish the finish on the workpiece.

4. Clean and inspect parts for damage. Replace if necessary.
- NOTE:** The protrusion on the retainer plate (22d) must point upward.
5. Reinstall the valve. Torque the screw (48) to 15-25 in-lb (1.7-2.8 N•m).

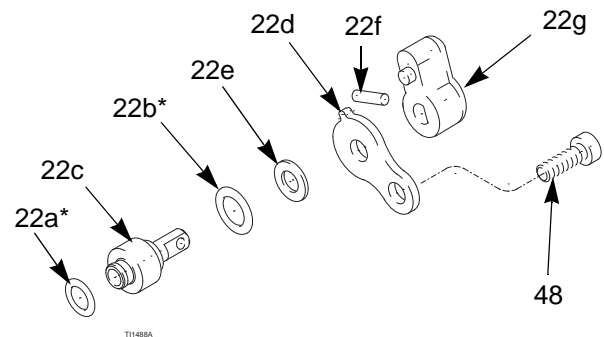
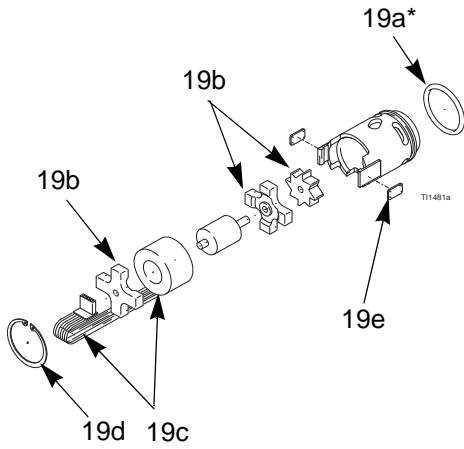


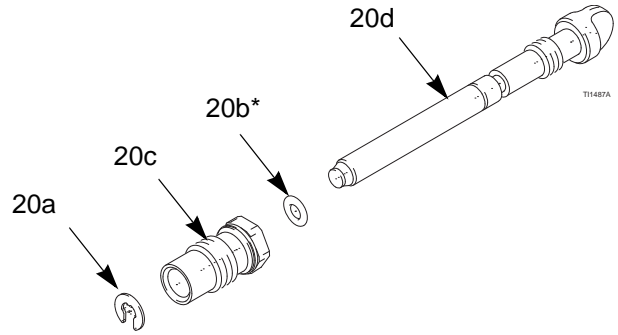
Fig. 36. ES ON/OFF Valve



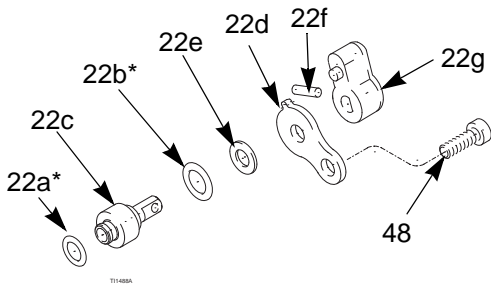
Ref. No. 19: Alternator



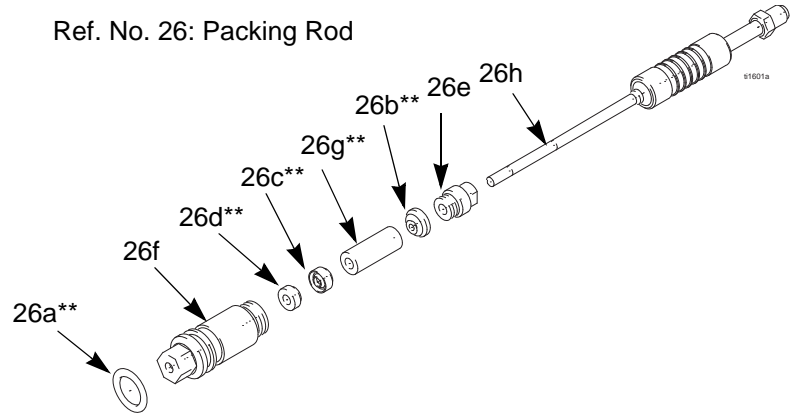
Ref. No. 20: Fan Adjustment Valve



Ref. No. 22: ES ON/OFF Valve



Ref. No. 26: Packing Rod



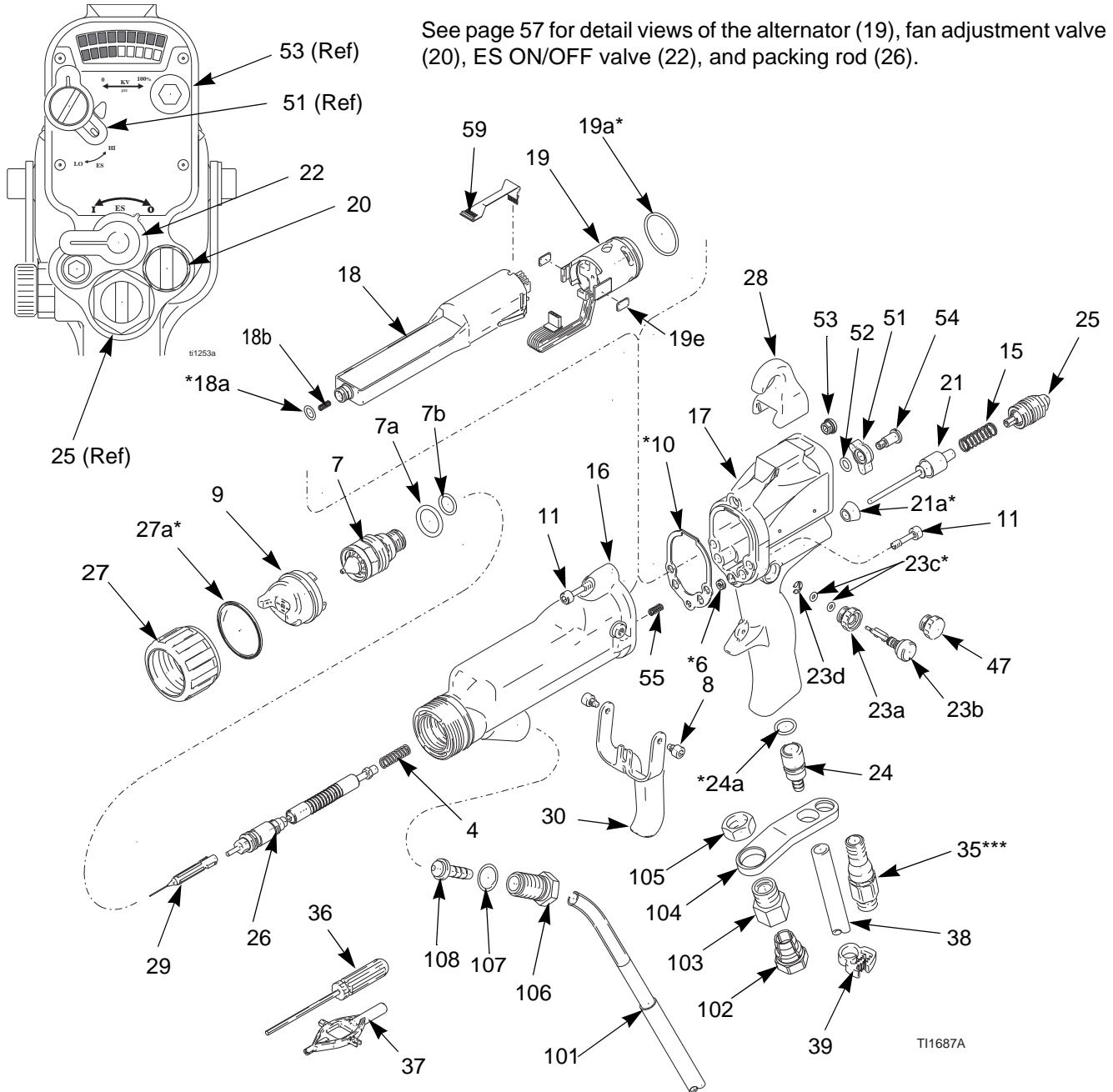
**Part No. 244581 60 kV Electrostatic Gun, Series B (items 4-55)****Part No. 245301 60 kV Electrostatic Gun with waterborne fluid hose, Series A (items 4-55, 101-108)**

Ref. No.	Part No.	Description	Qty	Ref. No.	Part No.	Description	Qty
				20c	197566	. HOUSING, fan valve	1
4	185111	SPRING, compression	1	20d	197567	. STEM, fan valve	1
6*	188749	PACKING, u-cup, air valve; uhmwpe	1	21	244557	VALVE, air	1
				21a*	276733	SEAL, fluoroelastomer	1
7	197266	NOZZLE; 1.5 mm orifice; includes 7a and 7b	1	22	244558	VALVE, electrostatics, ON/OFF; includes 22a-22g	1
7a	111261	. O-RING, conductive	1	22a*	111516	. O-RING; CV75	1
7b	111507	. O-RING; fluoroelastomer	1	22b*	113137	. O-RING; fluoroelastomer	1
8	197369	SCREW, trigger	2	22c	198403	. SHAFT, valve	1
9	24A276	AIR CAP	1	22d	198404	. PLATE, retaining	1
10*	197517	GASKET, barrel	1	22e	198453	. WASHER	1
11	197518	SCREW; socket-hd; 10-24 x 3/4 in. (19 mm)	3	22f	198464	. PIN	1
				22g	276753	. KNOB	1
15	185116	SPRING, compression	1	23	244559	VALVE, air, atomizing; includes 23a-23d	1
16	244394	BARREL, gun	1				
17	245292	HANDLE, gun; includes item 28	1	23a	197594	. HOUSING, valve	1
18	244542	POWER SUPPLY, 60 kV; includes 18a-18d	1	23b	197591	. SHAFT	1
18a*	103337	. O-RING; fluoroelastomer	1	23c*	168518	. O-RING; fluoroelastomer	2
18b	197624	. SPRING, compression	1	23d	101021	. RING, retaining	1
19	244555	TURBINE, alternator; includes 19a-19e	1	24	249323	VALVE, exhaust; includes 24a	1
				24a*	112085	. O-RING; fluorocarbon	1
19a*	110073	. O-RING; fluoroelastomer	1	25	244593	VALVE, adjustment, fluid	1
19b	223688	. BEARING KIT; includes front and rear bearings and fan	1	26	244521	ROD, packing; includes 26a-26h	1
19c	244577	. COIL	1	26a**	111316	. O-RING; fluoroelastomer	1
19d	111745	. RING, retaining	1	26b**	116905	. SEAL	1
19e	198821	. PAD, pressure	2	26c**	178409	. SPREADER, packing; uhmwpe	1
20	244556	VALVE, adjustment, fan; includes 20a-20d	1	26d**	178763	. PACKING, rod; acetal	1
20a	101021	. RING, retaining	1	26e	197641	. NUT, packing	1
20b*	106560	. O-RING; fluorocarbon	1	26f	185495	. HOUSING, packing	1
				26g**	186069	. SPACER, packing; acetal	1
				26h	244696	. ROD, packing	1

Ref. No.	Part No.	Description	Qty	Ref. No.	Part No.	Description	Qty
27	245790	RING, retaining; includes 27a	1	108	198640	. FITTING, seal	1
27a*	198307	. PACKING, u-cup	1	109	24A431	KIT, wide pattern (not shown)	1
28	276695	HOOK	1	* Included in Air Seal Repair Kit 244781.			
29	276867	NEEDLE, electrode; black	1	** Included in Fluid Seal Repair Kit 244911.			
30	276698	TRIGGER	1	*** Included in Swivel Repair Kit 244834.			
35***	245496	SWIVEL, air; 1/4 npsm(m); left-hand threads	1	<b>NOTE:</b> Replacement Warning labels, signs, tags, and cards are available at no cost.			
36	107460	WRENCH, ball end; 4 mm	1				
37	276741	MULTI-TOOL	1				
38	185103	TUBE, exhaust	1				
39	110231	CLAMP	1				
40	116553	GREASE, dielectric, tube (not shown)	1				
41	244915	COVER, gun; box of 10 (not shown)	1				
42	179791	TAG, warning (not shown); replacement available at no cost	1				
43	180060	SIGN, warning (not shown); replacement available at no cost	1				
47	197967	PLUG	1				
48	198058	SCREW, cap, socket hd	1				
55	197624	SPRING, grounding	1				
101	245252	HOSE, shielded waterborne fluid;	1				
	246431	HOSE, unshielded waterborne fluid; includes 102-108	1				
102	198663	. FERRULE (shielded hose 245252)	1				
	190863	FERRULE (unshielded hose 246431)	1				
103	185547	. HOUSING, ferrule (shielded hose 245252)	1				
	15B932	HOUSING, ferrule (unshielded hose 246431)	1				
104	197954	. BRACKET, fluid fitting	1				
105	185548	. NUT	1				
106	198643	. FITTING, barrel	1				
107	102982	. O-RING	1				

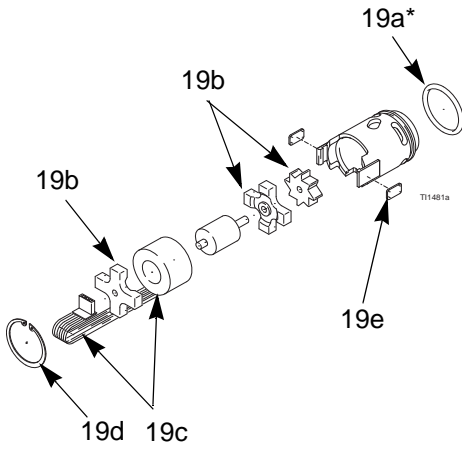
**Part No. 244582 60 kV Electrostatic Gun, Series B (items 4-59)**

**Part No. 245305 60 kV Electrostatic Gun with waterborne fluid hose, Series A (items 4-59, 101-108)**

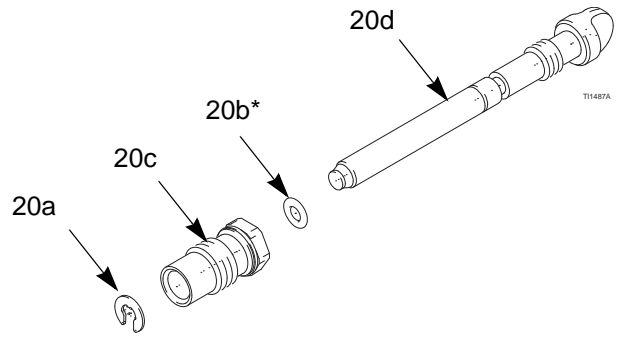




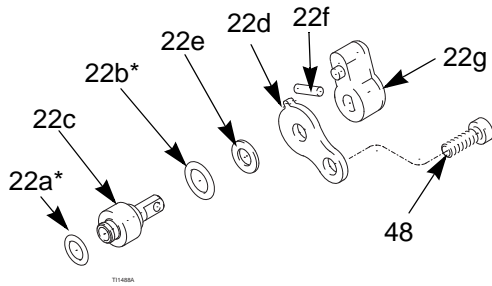
Ref. No. 19: Alternator



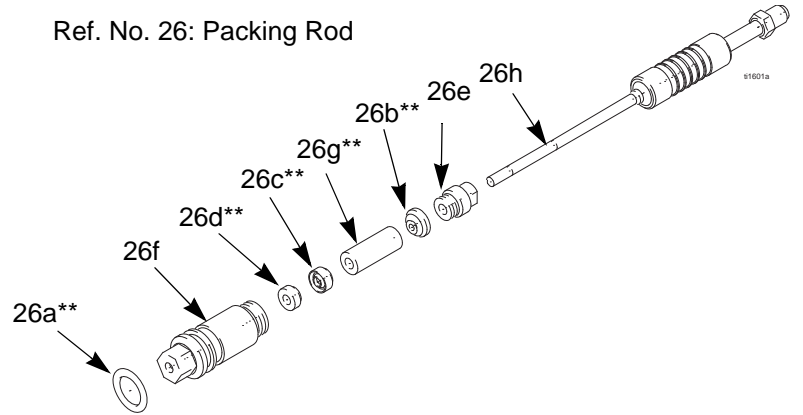
Ref. No. 20: Fan Adjustment Valve



Ref. No. 22: ES ON/OFF Valve



Ref. No. 26: Packing Rod



**Part No. 244582 60 kV Electrostatic Gun, Series B (items 4-59)****Part No. 245305 60 kV Electrostatic Gun with waterborne fluid hose, Series A (items 4-59, 101-108)**

Ref. No.	Part No.	Description	Qty	Ref. No.	Part No.	Description	Qty
				20b*	106560	. O-RING; fluorocarbon	1
4	185111	SPRING, compression	1	20c	197566	. HOUSING, fan valve	1
6*	188749	PACKING, u-cup, air valve; uhmwpe	1	20d	197567	. STEM, fan valve	1
				21	244557	VALVE, air; includes item 21a	1
7	197266	NOZZLE; 1.5 mm orifice; includes 7a and 7b	1	21a*	276733	. SEAL, fluoroelastomer	1
7a	111261	. O-RING, conductive	1	22	244558	VALVE, electrostatics, ON/OFF; includes 22a-22g	1
7b	111507	. O-RING; fluoroelastomer	1	22a*	111516	. O-RING; CV75	1
8	197369	SCREW, trigger	2	22b*	113137	. O-RING; fluoroelastomer	1
9	24A276	AIR CAP	1	22c	198403	. SHAFT, valve	1
10*	197517	GASKET, barrel	1	22d	198404	. PLATE, retaining	1
11	197518	SCREW; socket-hd; 10-24 x 3/4 in. (19 mm)	3	22e	198453	. WASHER	1
				22f	198464	. PIN	1
15	185116	SPRING, compression	1	22g	276753	. KNOB	1
16	244394	BARREL, gun	1	23	244559	VALVE, air, atomizing; includes 23a-23d	1
17	245293	HANDLE, gun; includes item 28	1	23a	197594	. HOUSING, valve	1
18	244542	POWER SUPPLY, 60 kV; includes 18a-18d	1	23b	197591	. SHAFT	1
18a*	103337	. O-RING; fluoroelastomer	1	23c*	168518	. O-RING; fluoroelastomer	2
18b	197624	. SPRING, compression	1	23d	101021	. RING, retaining	1
19	244555	TURBINE, alternator; includes 19a-19e	1	24	249323	VALVE, exhaust; includes 24a	1
19a*	110073	. O-RING; fluoroelastomer	1	24a*	112085	. O-RING; fluorocarbon	1
19b	223688	. BEARING KIT; includes front and rear bearings and fan	1	25	244593	VALVE, adjustment, fluid	1
19c	244577	. COIL	1	26	244521	ROD, packing; includes 26a-26h	1
19d	111745	. RING, retaining	1	26a**	111316	. O-RING; fluoroelastomer	1
19e	198821	. PAD, pressure	2	26b**	116905	. SEAL	1
20	244556	VALVE, adjustment, fan; includes 20a-20d	1	26c**	178409	. SPREADER, packing; uhmwpe	1
				26d**	178763	. PACKING, rod; acetal	1
20a	101021	. RING, retaining	1	26e	197641	. NUT, packing	1

Ref. No.	Part No.	Description	Qty	Ref. No.	Part No.	Description	Qty
26f	185495	. HOUSING, packing	1	102	198663	. FERRULE (shielded hose 245252)	1
26g**	186069	. SPACER, packing; acetal	1		190863	FERRULE (unshielded hose 246431)	1
26h	244696	. ROD, packing	1				
27	245790	RING, retaining, air cap; includes item 27a	1	103	185547	. HOUSING, ferrule (shielded hose 245252)	1
27a*	198307	. PACKING, u-cup	1		15B932	HOUSING, ferrule (unshielded hose 246431)	1
28	276695	HOOK	1	104	197954	. BRACKET, fluid fitting	1
29	276867	NEEDLE, electrode; black	1	105	185548	. NUT	1
30	276698	TRIGGER	1	106	198643	. FITTING, barrel	1
35***	245496	SWIVEL, air; 1/4 npsm(m); left-hand threads	1	107	102982	. O-RING	1
36	107460	WRENCH, ball end; 4 mm	1	108	198640	. FITTING, seal	1
37	276741	MULTI-TOOL	1	109	24A431	KIT, wide pattern (not shown)	1
38	185103	TUBE, exhaust	1	* Included in Air Seal Repair Kit 244781.			
39	110231	CLAMP	1	** Included in Fluid Seal Repair Kit 244911.			
40	116553	GREASE, dielectric, tube (not shown)	1	*** Included in Swivel Repair Kit 244834.			
41	244915	COVER, gun; box of 10 (not shown)	1	<b>NOTE:</b> Replacement Warning labels, signs, tags, and cards are available at no cost.			
42	179791	TAG, warning (not shown); replacement available at no cost	1	Part No. 245897 Isolation Enclosure, Series A, with air and shielded wb fluid hoses, standard Xs3 gun (items 201-301)			
43	180060	SIGN, warning (not shown); replacement available at no cost	1				
47	197967	PLUG	1				
48	198058	SCREW, cap, socket hd	1				
51	244627	SWITCH, ES HI/LO	1				
52	111450	O-RING	1				
53	276734	PLUG, LO voltage adjustment	1				
54	197910	SCREW, pivot	1				
55	197624	SPRING, grounding	1				
59	245265	CIRCUIT, flexible	1				
101	245252	HOSE, shielded waterborne fluid;	1				
	246431	HOSE, unshielded waterborne fluid; includes 102-108	1				



**Part No. 245897 Isolation Enclosure, Series A,  
with air and wb fluid hose, standard Xs3 gun (items 201-301)**

**Part No. 245898 Isolation Enclosure, Series A,  
with air and wb fluid hoses, smart Xs3 gun (items 201-301)**

**Part No. 233825 Isolation Enclosure, Series A, for shielded hoses without hoses and gun (items 201-286)**

Ref. No.	Part No.	Description	Qty	Ref. No.	Part No.	Description	Qty
				223	101390	WASHER, lock, internal tooth	1
201		CABINET, enclosure; includes 201a	1	224	154636	WASHER, plain; 0.625 in. ID	2
201a	15A947	DOOR, cabinet	1	225	185548	NUT	1
202	116993	CASTER, brake	4	226	190410	RESISTOR, bleed	1
203	15A660	PLATE	1	227	116988	CYLINDER ROD	1
204	15A551	T-HANDLE, latch	1	228	15A518	HOUSING, cylinder rod	1
205	15A545	STEM, handle, door	1	229	104267	REGULATOR, air	1
206	15A524	HOUSING, latch	1	230		BUSHING; plastic; 3/4 x 1/2 npt	1
207	113061	SWITCH, push, air	1	231	114456	ELBOW, tube; 3/8 npt x 3/8 in. (10 mm) OD tube	1
208		TUBE; 1/2 in. (13 mm) OD; polyethylene	A/R	232	116315	ELBOW, tube; 3/8 npt x 1/2 in. (13 mm) OD tube	1
209	233501	PUMP, diaphragm; sst; see manual 309303	1	235	15A682	LABEL, warning	1
210		SCREW, hex hd cap; 5/16-18 x 5.5 in. (140 mm)	2	236	116316	FITTING, tube; 1/2 npt x 1/2 in. (13 mm) OD tube	1
211		WASHER, plain; 0.344 in. ID	2	237	218798	STRAINER, 16 mesh; sst	1
212		NUT, lock; 5/16-18	2	238	114958	STRAP, tie	3
213	241005	COVER, pail	1	239	222011	GROUND WIRE, 25 ft (7.6 m)	1
214	104029	LUG, ground	1	240	234018	STRIP, grounding; aluminum	1
215	116989	VALVE, air	1	241	110209	NUT, regulator	1
216	111804	REGULATOR, air	1	242	114051	WASHER, shim, latch	1
217	113060	GAUGE, air; 1/8 npt	1	243	210084	ROD, ground	1
218	116473	VALVE, ball; 1/4 npt(fbe)	1	244		SCREW, hex hd; 1/4-20 x 5/8 in. (16 mm)	16
219	233824	CART, enclosure	1	245		WASHER, plain; 1/4 in. (6 mm)	16
220	162453	NIPPLE; 1/4 npt x 1/4 npsm	1	246		NUT, hex; 1/4-20	16
221	185547	FERRULE, housing (233825)	1	247	107257	SCREW, thread forming	1
	15B932	FERRULE, housing (246511)	1	248		TUBE; 1/4 in (6 mm) OD; nylon	A/R
222	198663	FERRULE (233825)	1	249	160430	GAUGE, air	1
	190863	FERRULE (246511)	1	251		WIRE, 10 gauge; green with yellow stripe	A/R

Parts

Ref. No.	Part No.	Description	Qty	Ref. No.	Part No.	Description	Qty
252		CONNECTOR, swivel tee; 1/8 npt x 5/32 in. (4 mm) OD tube	1	282		SWIVEL, tube; 1/4 npt x 1/4 in. (6 mm) OD tube	4
253		NUT, hex; 10-32	1	283		SWIVEL, tube; 1/8 npt x 5/32 in. (4 mm) OD tube	2
256	162449	NIPPLE, reducing; 1/2 npt x 1/4 npt	2	285	112791	CLAMP	1
257	101874	TERMINAL, ring	5	286		TUBE; 3/8 in. (10 mm) OD	A/R
258	116990	BOX, control	1	300	235070	HOSE, air, grounded; 0.315 in. (8 mm) ID; 1/4 npsm(f) x 1/4 npsm(f) left-hand thread; red cover with stainless steel braid ground path; 25 ft (7.6 m) long	1
259	113983	RING, retaining; 1/2 in. (13 mm)	1	301	245301	GUN, air spray, standard, electrostatic, for waterborne coatings; see page 52; used on Model 245897	1
260	237933	METER, 0-90 kV	1	301	245305	GUN, air spray, smart, electrostatic, for waterborne coatings; see page 56; used on Model 245898	1
261	113336	ADAPTER, 1/4 npt	1	<b>NOTE:</b> Replacement Warning labels, signs, tags, and cards are available at no cost.			
262		SCREW, pan hd; 10-32 x 5/8 in. (16 mm)	4				
263		SCREW, pan hd; 10-32 x 1/4 in. (6 mm)	1				
264		HOLDER, tie	3				
265		SCREW, button hd; 10-24 x 1.5 in. (38 mm)	2				
266		SCREW, button hd; 10-32 x 1.0 in. (25 mm)	2				
267		NUT, hex; M5 x 0.8	2				
268		WASHER, lock; no. 10	9				
270	116991	TEE, run, manifold	1				
271	203953	SCREW, hex hd cap with patch; 10-24 x 3/8 in. (10 mm)	1				
272		WIRE, 14 gauge; red	A/R				
273		WIRE, ground, 14 gauge; green with yellow stripe	A/R				
274	155541	UNION, swivel; 1/4 npt	1				
275	114261	TERMINAL, ring; no. 10	1				
276	15A780	PLUG, hex hd	1				
278	117314	BULKHEAD CONNECTOR; 1/4 npt	1				
279	113319	CONNECTOR, tube; 1/4 npt x 3/8 in. (10 mm) OD tube	2				
280		ELBOW, tube	1				
281		FITTING, tube; 1/8 npt x 5/32 in. (4 mm) tube	1				

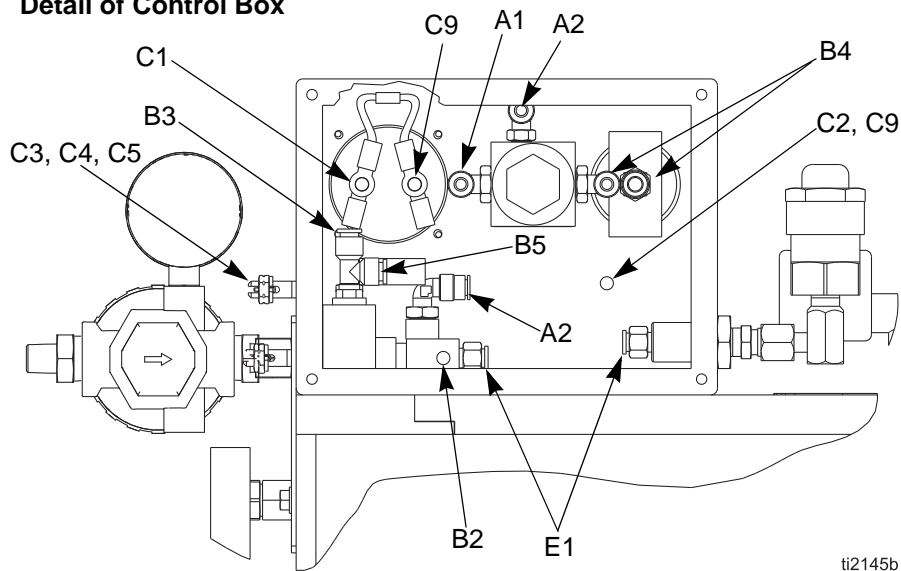
## Tubing and Wiring Chart

Use the diagrams on page 64 to find the connection points for the tubing and wiring listed below.

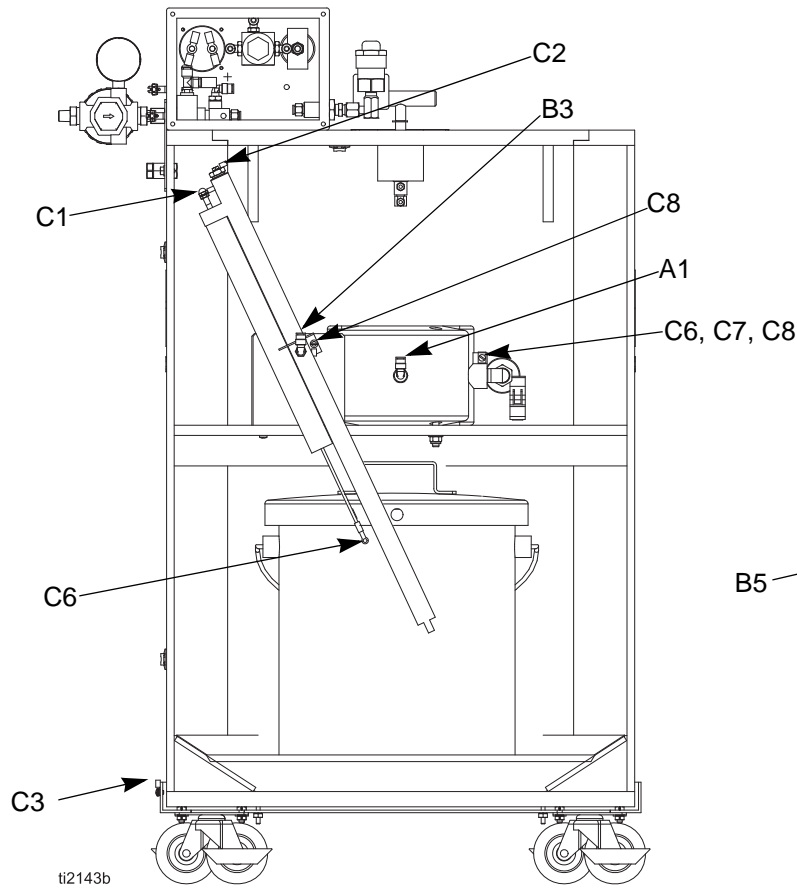
Code	Ref. No.	Length in. (mm)	Description
A1	248	20 (508)	1/4 OD tube, regulator to pump
A2	248	9 (229)	1/4 OD tube, regulator (216) to manifold
B2	249	17 (432)	5/32 OD tube, manifold air to door interlock switch
B3	249	20 (508)	5/32 OD tube, valve tee to cylinder
B4	249	5 (127)	5/32 OD tube, regulator (216) to gauge (2170)
B5	249	22 (559)	5/32 OD tube, valve tee to door interlock switch
C1	272	9 (229)	red 14 gauge wire from top of bleed resistor to meter
C2	251	8 (204)	green/yellow 14 gauge wire from internal box ground lug to cylinder cap
C3	273	34 (864)	green/yellow 10 gauge wire from external ground lug to cart
C4	239	n/a	green/yellow 25 ft ground wire with clamp, from external ground lug to true earth ground
C5	243	n/a	green/yellow 10 gauge wire from external ground lug to ground probe
C6	226	n/a	red wire from bleed resistor to pump
C7	272	16 (407)	red 14 gauge wire from pump to pail cover with clamp
C8	272	12 (305)	red 14 gauge wire from pump (209) to ground on cylinder bracket
C9	251	n/a	green/yellow 10 gauge wire from meter + to internal box ground lug
E1	286	4 (102)	3/8 OD tube, bulkhead to manifold

## Tubing and Wiring Diagrams

Detail of Control Box

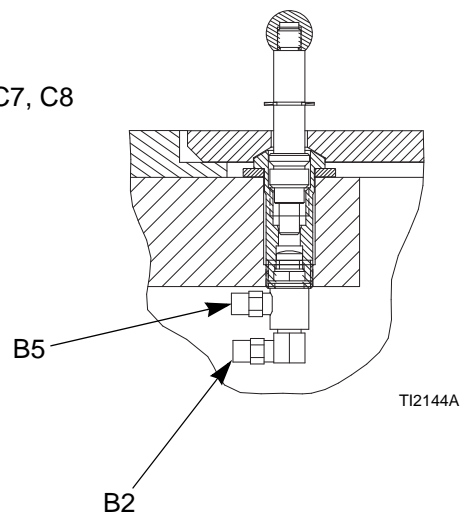


ti2145b



ti2143b

Detail of Door Interlock Switch



TI2144A



# Accessories

## Air Line Accessories

### Grounded Air Hose (Red Cover)

100 psi (7 bar, 0.7 MPa) Maximum Working Pressure

0.315 in. (8 mm) ID; 1/4 npsm(f) x 1/4 npsm(f) left-hand thread; red cover with stainless steel braid ground path.

<b>235068</b>	6 ft (1.8 m)
<b>235069</b>	15 ft (4.6 m)
<b>235070</b>	25 ft (7.6 m)
<b>235071</b>	36 ft (11 m)
<b>235072</b>	50 ft (15 m)
<b>235073</b>	75 ft (23 m)
<b>235074</b>	100 ft (30.5 m)

### Bleed-Type Master Air Valve

300 psi (21 bar, 2.1 MPa) Maximum Working Pressure

Relieves air trapped in the air line between this valve and the fluid supply unit when closed.

<b>107141</b>	3/4 npt
---------------	---------

### Air Line Shutoff Valve

150 psi (10 bar, 1.0 MPa) Maximum Working Pressure

For turning air to gun on or off.

<b>224754</b>	1/4 npsm(m) x 1/4 npsm(f) left-hand thread.
---------------	---

### Air Line Quick Disconnect

<b>112534</b>	Swiveling quick disconnect replaces standard air inlet swivel.
---------------	--

### Air Hose Adapter Nipple

<b>185493</b>	Use to connect multiple air hoses. 1/4 npt x 1/4 npsm left-hand thread.
---------------	---

### Non-Swivel Air Inlet Fitting

<b>185105</b>	Replaces standard swivel. Left-hand thread.
---------------	---

### Extended Air Inlet Fitting

<b>189191</b>	Replaces standard swivel to provide extended handle grip area. Left-hand thread.
---------------	--

## Fluid Line Accessories

### 245252 Shielded Waterborne Fluid Hose

100 psi (7 bar, 0.7 MPa) Maximum Working Pressure

FM Approved; PTFE; 1/4 in. (6 mm) ID x 25 ft (7.6 m)

For FM approved systems

### Fluid Shutoff/Drain Valve

500 psi (35 bar, 3.5 MPa) Maximum Working Pressure

For turning fluid on or off to the gun and for relieving fluid line pressure at the fluid supply unit.

<b>208630</b>	1/2 npt(m) x 3/8 npt(f); carbon steel and PTFE; for non-corrosive fluids
---------------	--

### 246431 Unshielded Waterborne Fluid Hose

100 psi (7 bar, 0.7 MPa) Maximum Working Pressure

FM Approved; PTFE; 1/4 in. (6 mm) ID x 25 ft (7.6 m)

For compliance with EN 50059.

## Gun Accessories

### Gun Repair Kits

- 244781 Air Seal Repair Kit
- 244911 Fluid Seal Repair Kit

### Round Pattern Kits

Consists of fluid tip, diffuser and air cap.

- 245217 4-6 in. (102-152 mm) diameter
- 245219 8-10 in. (203-254 mm) diameter

### Push/Pull Fan Air Valve

- 244912 For quick change of fan size.

### Handle Grips

- 245263 Medium Grip
- 245264 Large Grip

### Gun Valve Lubricant

- 111265 4 oz (113 g) tube of sanitary (non-silicone) lubricant for fluid seals and wear areas.

### Alternator Bearing Kit

- 223688 To repair the turbine alternator.

### Cleaning Brush

- 105749 For cleaning air cap and fluid nozzle.

## Miscellaneous Accessories

### Ground Wire and Clamp

- 222011 For grounding fluid supply unit and other components and equipment in the spray area.  
12 gauge, 25 ft (7.6 m).

### Megohmmeter

- 241079 500 Volt output; 0.01-2000 megohms.  
**Not for use in hazardous areas.**

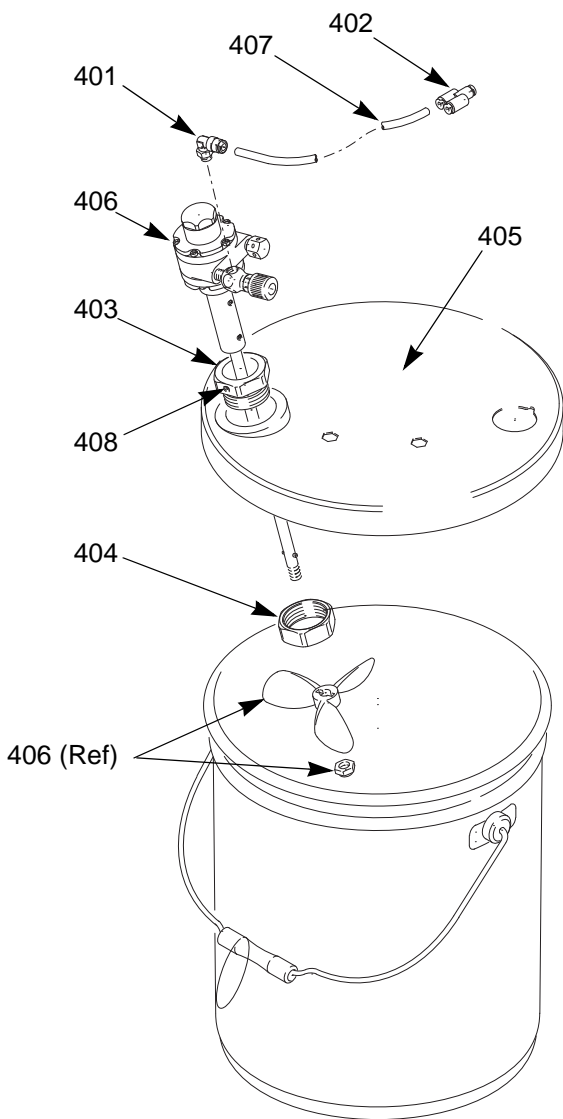
### Safety Warning Sign

- 186118 English Warning Sign. FM Approved. Available at no charge from Graco.

### Electrostatic Conductive Gloves (box of 12)

- 117823 Small
- 117824 Medium
- 117825 Large

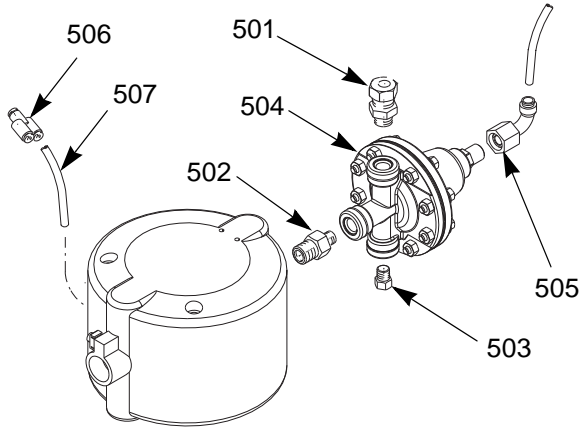
**Part No. 245895 Agitator Accessory Kit (items 401-408)**



Ref. No.	Part No.	Description	Qty
401	112698	ELBOW, swivel, male; 1/8 npt(m) x 1/4 in. (6 mm) OD tube	1
402	114158	FITTING, adapter, Y; 1/4 in. (6 mm) OD tube; mx fxf	1
403	193315	COLLAR, mounting, agitator	1
404	193316	NUT, collar, agitator	1
405	197298	COVER, pail; 5 gal. (19 liter); carbon steel lid	1
406	224571	AGITATOR; see manual 306565	1
407	purchase locally	TUBE; nylon; 1/4 in. (6 mm) OD; 4 ft (1.22 m)	1
408	110272	SCREW, set, socket-hd; 1/4-20 x 1/4 in. (6 mm)	1

T12137A

**Part No. 245944 Fluid Regulator Accessory Kit (items 501-507)**



T12149A

Ref. No.	Part No.	Description	Qty
501	110078	FITTING, tube, fluid; 1/4 npt(m) x 3/8 in. (10 mm) OD tube	1
502	113070	NIPPLE, reducer; 3/8 npt x 1/4 npt	1
503	113576	PLUG; 1/4 npt	1
504	236281	REGULATOR, fluid; see manual 308325	1
505	C20350	ELBOW, 90°; 1/4 npt(f) x 1/4 in. (6 mm) OD tube	1
506	114158	FITTING, adapter, Y; 1/4 in. (6 mm) OD tube; mxxf	1
507	purchase locally	TUBE; nylon; 1/4 in. (6 mm) OD; 4 ft (1.22 m)	1

# Technical Specifications

## Category

Maximum Working Fluid Pressure  
 Maximum Working Air Pressure  
 Minimum Air Pressure at Gun Inlet  
 Maximum Fluid Operating Temperature  
 Short Circuit Current Output  
 Voltage Output Energy

## Data

100 psi (0.7 MPa, 7 bar)  
 100 psi (0.7 MPa, 7 bar)  
 40 psi (0.28 MPa, 2.8 bar)  
 120°F (48°C)  
 125 microamperes  
 .35 J with fluid hose 246431 installed  
 244581, 245301: 60 kV  
 244582, 245305: 30-60 kV

Sound Power (measured per ISO Standard 9216)

at 40 psi (0.28 MPa, 2.8 bar): 90.4 dB(A)  
 at 100 psi (0.7 MPa, 7 bar): 105.4 dB(A)

Sound Pressure (measured 1 m from gun)

at 40 psi (0.28 MPa, 2.8 bar): 87 dB(A)  
 at 100 psi (0.7 MPa, 7 bar): 99 dB(A)

Gun Air Inlet Fitting, left-hand thread

1/4 npsm(m)

Gun Fluid Inlet Fitting

custom inlet for Graco waterborne fluid hose

Gun Weight

27.8 oz (788 g)

Gun Length

11.1 in. (28.2 cm)

Isolation Enclosure Air Inlet Fitting

1/4 npt

Isolation Enclosure Fluid Inlet Fitting

3/8 in. OD tube fitting

Isolation Enclosure Weight

125 lb (56.3 kg)

Isolation Enclosure Height

44 in. (1118 mm)

Isolation Enclosure Width

24 in. (610 mm)

Isolation Enclosure Depth

29 in. (737 mm)

Wetted Parts

*Gun:* Stainless Steel; Nylon, Acetal, Ultra-High Molecular Weight Polyethylene, Fluoroelastomer, PEEK, Tungsten Wire, Polyethylene  
*Waterborne Fluid Hose:* PTFE  
*Suction Tube:* Polyethylene, Stainless Steel  
*Triton Pump:* See manual 309303

Loctite® is a registered trademark of the Loctite Corporation.

## California Proposition 65

### CALIFORNIA RESIDENTS



**WARNING:** Cancer and reproductive harm – [www.P65warnings.ca.gov](http://www.P65warnings.ca.gov).

# Graco Standard Warranty

Graco warrants all equipment manufactured by Graco and bearing its name to be free from defects in material and workmanship on the date of sale to the original purchaser for use. With the exception of any special, extended, or limited warranty published by Graco, Graco will, for a period of twelve months or two thousand hours of operation from the date of sale, repair or replace any part of the equipment determined by Graco to be defective. However, any deficiency in the barrel, handle, trigger, hook, internal power supply, and alternator (excluding turbine bearings) will be repaired or replaced for thirty-six months or six thousand hours of operation from the date of sale. This warranty applies only when the equipment is installed, operated and maintained in accordance with Graco's written recommendations.

This warranty does not cover, and Graco shall not be liable for general wear and tear, or any malfunction, damage or wear caused by faulty installation, misapplication, abrasion, corrosion, inadequate or improper maintenance, negligence, accident, tampering, or substitution of non-Graco component parts. Nor shall Graco be liable for malfunction, damage or wear caused by the incompatibility of Graco equipment with structures, accessories, equipment or materials not supplied by Graco, or the improper design, manufacture, installation, operation or maintenance of structures, accessories, equipment or materials not supplied by Graco.

This warranty is conditioned upon the prepaid return of the equipment claimed to be defective to an authorized Graco distributor for verification of the claimed defect. If the claimed defect is verified, Graco will repair or replace free of charge any defective parts. The equipment will be returned to the original purchaser transportation prepaid. If inspection of the equipment does not disclose any defect in material or workmanship, repairs will be made at a reasonable charge, which charges may include the costs of parts, labor, and transportation.

**THIS WARRANTY IS EXCLUSIVE, AND IS IN LIEU OF ANY OTHER WARRANTIES, EXPRESS OR IMPLIED, INCLUDING BUT NOT LIMITED TO WARRANTY OF MERCHANTABILITY OR WARRANTY OF FITNESS FOR A PARTICULAR PURPOSE.**

Graco's sole obligation and buyer's sole remedy for any breach of warranty shall be as set forth above. The buyer agrees that no other remedy (including, but not limited to, incidental or consequential damages for lost profits, lost sales, injury to person or property, or any other incidental or consequential loss) shall be available. Any action for breach of warranty must be brought within two (2) years of the date of sale.

Graco makes no warranty, and disclaims all implied warranties of merchantability and fitness for a particular purpose in connection with accessories, equipment, materials or components sold but not manufactured by Graco. These items sold, but not manufactured by Graco (such as electric motors, switches, hose, etc.), are subject to the warranty, if any, of their manufacturer. Graco will provide purchaser with reasonable assistance in making any claim for breach of these warranties.

In no event will Graco be liable for indirect, incidental, special or consequential damages resulting from Graco supplying equipment hereunder, or the furnishing, performance, or use of any products or other goods sold hereto, whether due to a breach of contract, breach of warranty, the negligence of Graco, or otherwise.

## **FOR GRACO CANADA CUSTOMERS**

The parties acknowledge that they have required that the present document, as well as all documents, notices and legal proceedings entered into, given or instituted pursuant hereto or relating directly or indirectly hereto, be drawn up in English. Les parties reconnaissent avoir convenu que la rédaction du présente document sera en Anglais, ainsi que tous documents, avis et procédures judiciaires exécutés, donnés ou intentés à la suite de ou en rapport, directement ou indirectement, avec les procédures concernées.

# Graco Information

**For the latest information about Graco products, visit [www.graco.com](http://www.graco.com).**

**For patent information, see [www.graco.com/patents](http://www.graco.com/patents).**

**TO PLACE AN ORDER, contact your Graco distributor or call to identify the distributor closest to you:**

**Phone: 612-623-6921 or Toll Free: 1-800-328-0211 Fax: 612-378-3505**

*All written and visual data contained in this document reflects the latest product information available at the time of publication. Graco reserves the right to make changes at any time without notice.*

Original instructions. This manual contains English. MM 309293

**Graco Headquarters:** Minneapolis

**International Offices:** Belgium, China, Japan, Korea

**GRACO INC. AND SUBSIDIARIES • P.O. BOX 1441 • MINNEAPOLIS MN 55440-1441 • USA**

**Copyright 2002, Graco Inc. All Graco manufacturing locations are registered to ISO 9001.**

[www.graco.com](http://www.graco.com)

Revision N, December 2020