

# Bulk Grease Transfer Packages

309350C

EN

**For side pocket and horizontally mounting bulk grease transfer packages. For professional use only.**

**Not approved for use in European explosive atmosphere locations.**

**Model Number 244644, 50:1 Fire-Ball® 300 Side Pocket Mount**

100 psi (0.7 MPa, 7 bar) Maximum Air Working Pressure  
5000 psi (34.5 MPa, 345 bar) Maximum Fluid Working Pressure

**Model Number 244645, 50:1 Fire-Ball 300 Horizontal Mount**

100 psi (0.7 MPa, 7 bar) Maximum Air Working Pressure  
5000 psi (34.5 MPa, 345 bar) Maximum Fluid Working Pressure

**Model Number 244646, 50:1 Fire-Ball 425 Side Pocket Mount**

80 psi (0.55 MPa, 5.5 bar) Maximum Air Working Pressure  
4000 psi (27.6 MPa, 276 bar) Maximum Fluid Working Pressure

**Model Number 244647, 75:1 Fire-Ball 425 Side Pocket Mount**

53 psi (0.37 MPa, 3.7 bar) Maximum Air Working Pressure  
4000 psi (27.6 MPa, 276 bar) Maximum Fluid Working Pressure

**Model Number 244648, 75:1 Fire-Ball 425 Horizontal Mount**

53 psi (0.37 MPa, 3.7 bar) Maximum Air Working Pressure  
4000 psi (27.6 MPa, 276 bar) Maximum Fluid Working Pressure

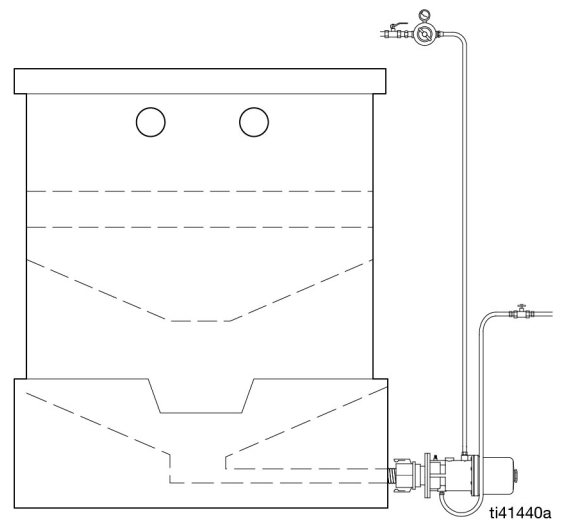

**Important Safety Instructions**

For complete warnings refer to the Operating and/or Repair for manual 50:1 Fire-Ball 300 Pump, 75:1 Fire-Ball 425 Pumps, President® Air Motors, or Fire-Ball 300 and 425 Grease Pumps.

## Related Manuals

Manual in English	Description
308883	50:1 Fire-Ball 300 Pump
306674	50:1 Fire-Ball 425 Pumps
308777	75:1 Fire-Ball 425 Pumps
306982	President® Air Motors
307880	Fire-Ball 300 and 425 Grease Pumps

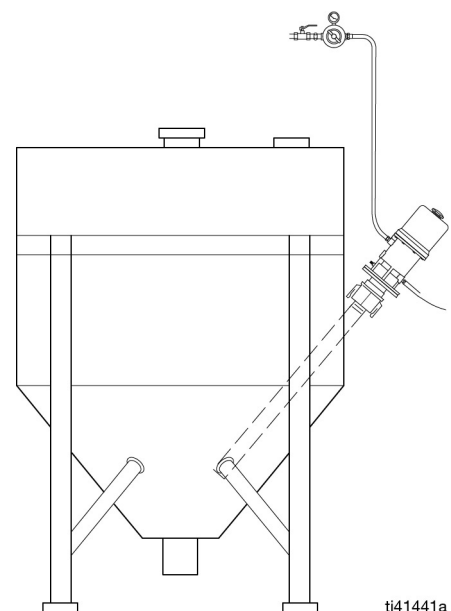

# Parts

### Horizontal Mount

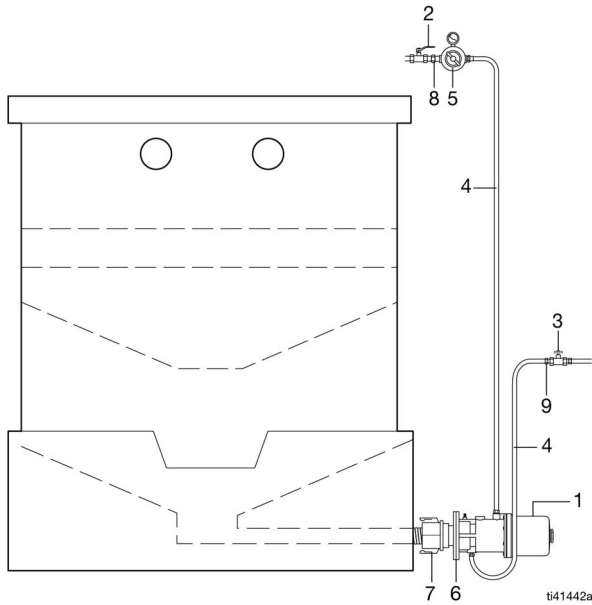

ti41442a

### Side Pocket Mount

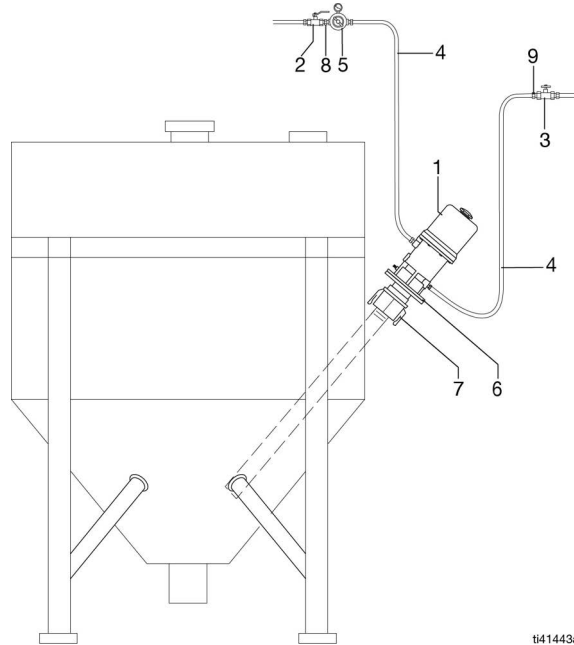

ti41443a

## Part Number/Assembly Name

Ref.	Part	Description	Qty.
1	239888	PUMP, 50:1 Fireball 300 (Model 244644) See <b>Related Manuals</b> , page 1.	1
	239877	PUMP, 50:1 Fireball 300 (Model 244645) See <b>Related Manuals</b> , page 1.	1
	205395	PUMP, 50:1 Fireball 425 (Model 244646) See <b>Related Manuals</b> , page 1.	1
	239730	PUMP, 75:1 Fireball 425 (Model 244647) See <b>Related Manuals</b> , page 1.	1
	239731	PUMP, 75:1 Fireball 425 (Model 244648) See <b>Related Manuals</b> , page 1.	1
2	110224	VALVE, air shutoff, 3/8 npt(fbe) (Models 244644 and 244645.)	1
	110225	VALVE, air shutoff, 1/2 npt(fbe) (Models 244646, 244647, and 244648.)	1
3	202869	VALVE, fluid shutoff, 1/2 npt(fbe)	1
4	222072	KIT, hose and fitting (Models 244644 and 244645) See <b>Related Manuals</b> , page 1.	1
	222076	KIT, hose and fitting (Models 244646, 244647, and 244648) See <b>Related Manuals</b> , page 1.	1
5	109075	REGULATOR, air, 3/8 npt(fbe) (Includes gauge. Models 244644 and 244645. (See manual 308167.)	1
	244844	REGULATOR, air, 1/2 npt(fbe) (Includes gauge. Models 244646, 244647, and 244648. See manual 308167.)	1

Ref.	Part	Description	Qty.
6	948393	ADAPTER, flange (Models 244644 and 244645.)	1
	948392	ADAPTER, flange (Models 244646, 244647, and 244648.)	1
7	512874	COUPLER, 3 npt(f)	1
8	156849	NIPPLE, 3/8 npt (Models 244644 and 244645.)	1
	158491	NIPPLE, 1/2 npt (Models 244646, 244647, and 244648.)	1
9	100206	BUSHING, 1/2 npt(m) X 1/4 npt(f) (Models 244644 and 244645.)	1
	100081	BUSHING, 1/2 npt(m) X 3/8 npt(f) (Models 244646, 244647, and 244648.)	1

# Recycling and Disposal

## End of Product Life

At the end of the product’s useful life, dismantle and recycle it in a responsible manner.

- Perform the Pressure Relief Procedure for your pump manual
- Drain and dispose of fluids according to applicable regulations. Refer to the material manufacturer’s Safety Data Sheet.
- Deliver remaining product to a recycling facility.

## Technical Specifications

The system maximum air and fluid working pressure ratings are on the cover. See the separate Technical Data/Technical Specifications section in the pump and motor instruction manuals that came with your pump/motor.

Wetted parts	
Pump	See separate pump instruction manuals
Output fitting, hose, valve	Steel, brass, rubber

## California Proposition 65

### CALIFORNIA RESIDENTS

 **WARNING:** Cancer and reproductive harm – [www.P65warnings.ca.gov](http://www.P65warnings.ca.gov).

# Graco Standard Warranty

Graco warrants all equipment referenced in this document which is manufactured by Graco and bearing its name to be free from defects in material and workmanship on the date of sale to the original purchaser for use. With the exception of any special, extended, or limited warranty published by Graco, Graco will, for a period of twelve months from the date of sale, repair or replace any part of the equipment determined by Graco to be defective. This warranty applies only when the equipment is installed, operated and maintained in accordance with Graco's written recommendations.

This warranty does not cover, and Graco shall not be liable for general wear and tear, or any malfunction, damage or wear caused by faulty installation, misapplication, abrasion, corrosion, inadequate or improper maintenance, negligence, accident, tampering, or substitution of non-Graco component parts. Nor shall Graco be liable for malfunction, damage or wear caused by the incompatibility of Graco equipment with structures, accessories, equipment or materials not supplied by Graco, or the improper design, manufacture, installation, operation or maintenance of structures, accessories, equipment or materials not supplied by Graco.

This warranty is conditioned upon the prepaid return of the equipment claimed to be defective to an authorized Graco distributor for verification of the claimed defect. If the claimed defect is verified, Graco will repair or replace free of charge any defective parts. The equipment will be returned to the original purchaser transportation prepaid. If inspection of the equipment does not disclose any defect in material or workmanship, repairs will be made at a reasonable charge, which charges may include the costs of parts, labor, and transportation.

**THIS WARRANTY IS EXCLUSIVE, AND IS IN LIEU OF ANY OTHER WARRANTIES, EXPRESS OR IMPLIED, INCLUDING BUT NOT LIMITED TO WARRANTY OF MERCHANTABILITY OR WARRANTY OF FITNESS FOR A PARTICULAR PURPOSE.**

Graco's sole obligation and buyer's sole remedy for any breach of warranty shall be as set forth above. The buyer agrees that no other remedy (including, but not limited to, incidental or consequential damages for lost profits, lost sales, injury to person or property, or any other incidental or consequential loss) shall be available. Any action for breach of warranty must be brought within two (2) years of the date of sale.

**GRACO MAKES NO WARRANTY, AND DISCLAIMS ALL IMPLIED WARRANTIES OF MERCHANTABILITY AND FITNESS FOR A PARTICULAR PURPOSE, IN CONNECTION WITH ACCESSORIES, EQUIPMENT, MATERIALS OR COMPONENTS SOLD BUT NOT MANUFACTURED BY GRACO.** These items sold, but not manufactured by Graco (such as electric motors, switches, hose, etc.), are subject to the warranty, if any, of their manufacturer. Graco will provide purchaser with reasonable assistance in making any claim for breach of these warranties.

In no event will Graco be liable for indirect, incidental, special or consequential damages resulting from Graco supplying equipment hereunder, or the furnishing, performance, or use of any products or other goods sold hereto, whether due to a breach of contract, breach of warranty, the negligence of Graco, or otherwise.

## **FOR GRACO CANADA CUSTOMERS**

The Parties acknowledge that they have required that the present document, as well as all documents, notices and legal proceedings entered into, given or instituted pursuant hereto or relating directly or indirectly hereto, be drawn up in English. Les parties reconnaissent avoir convenu que la rédaction du présente document sera en Anglais, ainsi que tous documents, avis et procédures judiciaires exécutés, donnés ou intentés, à la suite de ou en rapport, directement ou indirectement, avec les procédures concernées.

# Graco Information

For the latest information about Graco products, visit [www.graco.com](http://www.graco.com).

For patent information, see [www.graco.com/patents](http://www.graco.com/patents).

**TO PLACE AN ORDER**, contact your Graco distributor or call to identify the nearest distributor.

**Phone:** 612-623-6928 **or Toll Free:** 1-800-533-9655, **Fax:** 612-378-3590

*All written and visual data contained in this document reflects the latest product information available at the time of publication. Graco reserves the right to make changes at any time without notice.*

Original instructions. This manual contains English. MM 309350

**Graco Headquarters:** Minneapolis

**International Offices:** Belgium, China, Japan, Korea

**GRACO INC. AND SUBSIDIARIES • P.O. BOX 1441 • MINNEAPOLIS MN 55440-1441 • USA**  
**Copyright 2001, Graco Inc. All Graco manufacturing locations are registered to ISO 9001.**

[www.graco.com](http://www.graco.com)  
Revision C, June 2022