

# Instructions – Parts List



## 10:1 Fire-Ball® 425 Pump

309407E

EN

**Low-pressure, medium volume pump used to transfer grease.**

*1800 psi (12.4 MPa, 124 bar) Maximum Working Pressure*

*180 psi (1.3 MPa, 13 bar) Maximum Air Inlet Pressure*

**Model No. 965124, Series B, Stubby length**

**Model No. 965129, Series B, 400 lb (180 Kg) drum length**  
For Closed Drum Mounting



**Important Safety instructions.**

Read all warnings and instructions in this manual.  
Save these instructions.

### **WARNING**

This pump is designed to be used only in pumping non-corrosive and non-abrasive lubricants. Any other use of the pump can cause unsafe operating conditions and component rupture, which can result in fluid injection or other serious injury or fire or explosion.

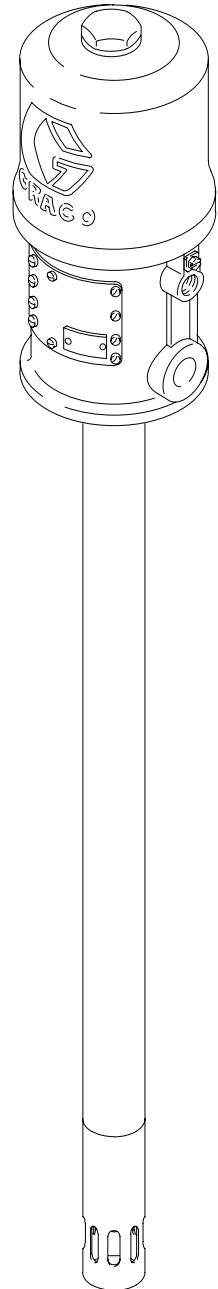

TI2146A

# Table of Contents

Warnings .....	2	Parts .....	14
Installation .....	5	Dimensions .....	16
Operation .....	7	Technical Data .....	17
Maintenance .....	7	Graco Standard Warranty .....	18
Troubleshooting .....	8	Graco Information .....	18
Service .....	10		

## Symbols

### Warning Symbol





This symbol alerts you to the possibility of serious injury or death if you do not follow the instructions.

### Caution Symbol



This symbol alerts you to the possibility of damage to or destruction of equipment if you do not follow the instructions.

## ! WARNING

 	<p><b>SKIN INJECTION HAZARD</b></p> <p>High-pressure fluid from dispense device, hose leaks, or ruptured components will pierce skin. This may look like just a cut, but it is a serious injury that can result in amputation. <b>Get immediate surgical treatment.</b></p> <ul style="list-style-type: none"> <li>• Do not point the dispensing device at anyone or any part of the body.</li> <li>• Do not put your hand over the end of the fluid outlet.</li> <li>• Do not stop or deflect leaks with your hand, body, glove, or rag.</li> <li>• Follow the <b>Pressure Relief Procedure</b> on page 7 before you clean, check, or service the equipment.</li> <li>• Tighten all fluid connections before operating the equipment.</li> <li>• Check the hoses and couplings daily. Replace worn or damaged parts immediately.</li> </ul>
	<p><b>MOVING PARTS HAZARD</b></p> <p>Moving parts can pinch or amputate your fingers.</p> <ul style="list-style-type: none"> <li>• Keep clear of all moving parts when starting or operating the pump.</li> <li>• Before checking or servicing the equipment, follow the <b>Pressure Relief Procedure</b> on page 7 to prevent the equipment from starting unexpectedly.</li> </ul>

# WARNING



## FIRE AND EXPLOSION HAZARD

Improper grounding, poor ventilation, open flames, or sparks can cause a hazardous condition and result in a fire or explosion and serious injury.

- Ground the equipment and the object being dispensed to. Refer to **Grounding** on page 5.
- If there is any static sparking or you feel an electric shock while using this equipment, **stop dispensing immediately**. Do not use the equipment until you identify and correct the problem.
- Provide fresh air ventilation to avoid the buildup of flammable fumes from solvents or the fluid being dispensed.
- Keep the dispensing area free of debris, including solvent, rags, and gasoline.
- Do not smoke in the dispensing area.
- Do not turn on or off any light switch in the area while dispensing if fumes are present.
- Never use 1.1.1-trichloroethane, methylene chloride, other halogenated hydrocarbon solvents, or fluids containing such solvents in pressurized aluminum equipment. Such use could result in a chemical reaction, with the possibility of explosion.



## TOXIC FLUID HAZARD

Hazardous fluid or toxic fumes can cause serious injury or death if splashed in the eyes or on the skin, inhaled, or swallowed.

- Know the specific hazards of the fluid you are using.
- Store hazardous fluid in an approved container. Dispose of hazardous fluid according to all local, state, and national guidelines.
- Always wear protective eyewear, gloves, clothing, and respirator as recommended by the fluid and solvent manufacturer.
- The air motor exhausts any fluids added to the input air.
- Graco does not manufacture or supply the reactive chemical components that may be used in this equipment and is not responsible for injury or property loss, damage, expense, or claims (direct or consequential) that arise from the use of such chemical components.

# WARNING



INSTRUCTIONS

## EQUIPMENT MISUSE HAZARD

Equipment misuse can cause the equipment to rupture or malfunction and result in serious injury.

- This equipment is for professional use only.
- Read all instruction manuals, tags, and labels before operating the equipment.
- Use the equipment only for its intended purpose. If you are not sure, call your Graco distributor.
- Do not alter or modify this equipment.
- Check equipment daily. Repair or replace worn or damaged parts immediately.
- Do not exceed the maximum working pressure stated on the equipment or in the **Technical Data** for your equipment. Do not exceed the maximum working pressure of the lowest rated component in your system.
- Use fluids and solvents which are compatible with the equipment wetted parts. Refer to the **Technical Data** section of all equipment manuals. Read the fluid and solvent manufacturer's warnings.
- Handle hoses carefully. Do not pull on hoses to move equipment.
- Route hoses away from traffic areas, sharp edges, moving parts, and hot surfaces. Do not expose Graco hoses to temperatures above 66°C (150°F) or below -40°C (-40°F).
- Wear hearing protection when operating this equipment.
- Do not move or lift pressurized equipment.
- Comply with all applicable local, state, and national fire, electrical, and safety regulations.

# Installation

**NOTE:** Reference numbers and letters in parentheses in the text refer to the callouts in the figures and the parts drawing.

**NOTE:** Always use Genuine Graco Parts and Accessories, available from your Graco distributor.

## Grounding

**⚠ WARNING**

**FIRE AND EXPLOSION HAZARD**  
Before operating the pump, ground the system as explained below. Also read the section **FIRE OR EXPLOSION HAZARD** on page 3.

- *Pump:* Use a ground wire and clamp as shown below.

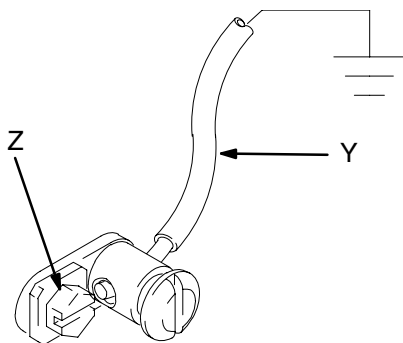

**Fig. 1**

TI1052

- *Air and fluid hoses:* Use only electrically conductive hoses.
- *Air compressor:* Follow manufacturer's recommendations.

- *Dispensing valve:* Ground through connection to a properly grounded fluid hose and pump.
- *Object being dispensed to:* Follow your local code.
- *Solvent pails used when flushing:* Follow your local code. Use only metal pails, which are conductive, placed on a grounded surface. Do not place the pail on a nonconductive surface, such as paper or cardboard, which interrupts the grounding continuity.
- *To maintain grounding continuity when flushing or relieving pressure,* hold a metal part of the dispensing gun firmly to the side of a grounded metal pail, then trigger the gun to ground the pump.

**To ground the pump,** remove the ground screw (Z) and insert through the eye of the ring terminal at end of ground wire (Y). Fasten the ground screw back onto the pump and tighten securely. Connect the other end of the ground wire to a true earth ground. See Fig. 1. *To order a ground wire and clamp, order Part No. 222011.*

## Mounting the Pump

**⚠ WARNING**

Mount the pump securely so that it cannot move around during operation. Failure to do so could result in personal injury or equipment damage.

- Select a convenient location for the equipment to ensure easy operator access to the pump air controls, sufficient room to change supply containers, and a secure mounting platform.
- If you are mounting the pump directly on the supply tank, position the pump so its intake valve is no more than 1 in. (25 mm) from the bottom of the container. Mount the pump to the cover or other suitable mounting device.

# Installation

Mount the pump to suit the type of installation planned. Very heavy lubricants may require an inductor plate. See page 16 for the mounting hole layout and dimensions

Install the air line accessories in the approximate order shown in the Typical Installation. Install a bleed-type master air valve (B) within easy reach of the pump, upstream from the air regulator. Install an air filter (C) to remove harmful dirt and moisture from your compressed air supply. For automatic air motor lubrication, install an air line oiler (D) close to the pump air inlet. Install an air regulator (E) to control pump speed.

## **! WARNING**

A bleed-type master air valve (B) is required to shut off and relieve air pressure that may be trapped in the air motor. Trapped air could cause the pump to cycle unexpectedly and cause serious bodily injury, including amputation.

Be sure the air hose is properly sized to deliver an adequate supply of air to the motor. Refer to the Technical Data on page 17.

Connect a dispensing hose to the 3/4 npt(f) pump outlet. Install an appropriate gun or dispensing valve to the hose.

Ground the pump as explained on page 5.

## Typical Installation

### Key

- A Grounded Air Line
- B Bleed-type Master Air Valve
- C Air Filter
- D Air Line Oiler
- E Air Regulator
- F Grounded Dispensing Hose
- H Elevator Assy. 241663
- J Ground Wire
- K Follow Plate 223701
- L Drum Cover 200326

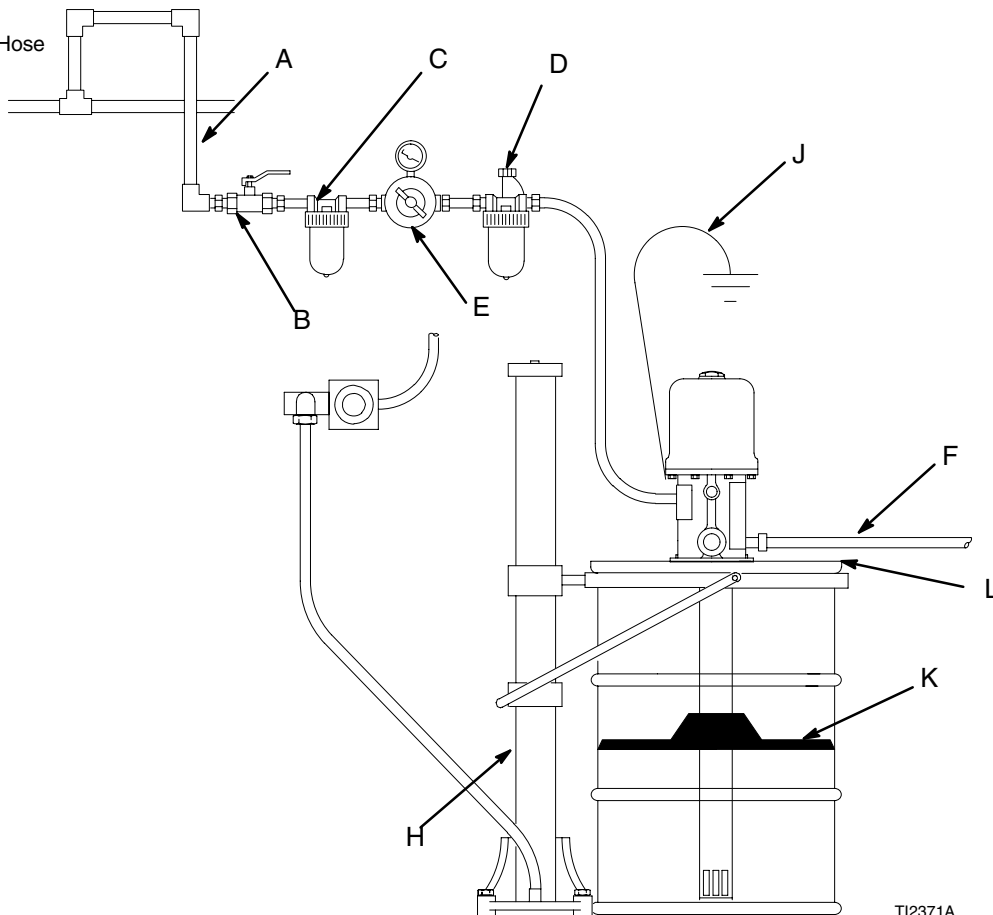

Fig. 2

# Operation

## ⚠ WARNING

- This pump is designed to be used **ONLY** in pumping non-corrosive and non-abrasive lubricants and greases. Any other use of this pump can cause unsafe operating conditions and result in component rupture, fire, or explosion, which can cause serious bodily injury, including injection.
- Moving parts can pinch or amputate your fingers or other body parts. When the pump is operating, the priming piston (located at the pump intake) and the air motor piston (located behind the air motor plates) move. **NEVER** Operate the pump with the air motor plates removed, and keep your fingers and hands away from the priming piston.

## Pressure Relief Procedure

## ⚠ WARNING

 **SKIN INJECTION HAZARD**  
Fluid under high pressure can be injected through the skin and cause serious injury. To reduce the risk of an injury from injection, splashing fluid, or moving parts, follow the **Pressure Relief Procedure** whenever you

- Are instructed to relieve the pressure
- Stop dispensing
- Check or service any of the system equipment
- Install or clean the dispensing nozzles

1. Close the air regulators.
2. Close the supply pump's bleed-type master air valve (required in this system).
3. Open the dispensing valve until pressure is fully relieved.

*If you suspect that the dispensing valve, extension, or grease fitting coupler is clogged, or that pressure has not been fully relieved after following the steps above, VERY SLOWLY loosen the coupler or hose end coupling and relieve pressure gradually, then loosen completely, then clear the clog.*

## Startup and Adjustment

Open the bleed-type master air valve. Open the dispensing valve, and slowly open the air regulator until the pump is running smoothly. After all the air is purged, close the dispensing valve. The pump will start and stop as the valve is opened and closed.

## ⚠ CAUTION

Never allow the pump to run dry of the fluid being pumped. A dry pump quickly accelerates to a high speed and may damage itself. If your pump accelerates quickly or is running too fast, stop it immediately and check the fluid supply. If the supply container is empty and air has been pumped into the lines, prime the pump and lines with fluid, or flush the pump and leave it filled with a compatible solvent. Be sure to eliminate all air from the fluid system.

Use the air regulator (E) to control the pump speed and fluid pressure. See Fig. 2. Always use the lowest pressure necessary to obtain the desired results.

When you are finished using the pump for the day, always follow the **Pressure Relief Procedure** at left.

# Maintenance

The Accessory air line oiler (D) provides automatic air motor lubrication. For daily manual lubrication, disconnect the air hose, place about 15 drops of light machine oil in the air inlet, reconnect the hose, and turn on the air supply to blow oil into the motor.

# Troubleshooting

## WARNING

To reduce the risk of serious injury whenever you are instructed to relieve pressure, always follow the **Pressure Relief Procedure** on page 7.

Before servicing this equipment always make sure to **Relieve the Pressure**.

**Note:** Check all possible problems and solutions before disassembling the pump.

Problem	Cause	Solution
Pump fails to operate.	Inadequate air supply pressure or restricted air lines	Increase air supply; clear
	Closed or clogged valves	Open; clean
	Clogged fluid lines, hoses, valves, etc.	Clear*
	Damaged air motor	Service air motor
	Exhausted fluid supply	Refill and reprime, or flush
Continuous air exhaust	Worn or damaged air motor gasket, packing, seal, etc.	Service air motor
Erratic pump operation	Exhausted fluid supply	Refill and reprime, or flush
	Held open or worn intake valve or piston packings	Clear; service
Pump operates, but output low on upstroke	Held open or worn piston or packings	Clear; service
Pump operates, but output low on downstroke	Held open or worn intake valve	Clear; service
Pump operates, but output low on both strokes	Inadequate air supply or restricted air lines	Increase air supply; clear
	Closed or clogged valves	Open; clean
	Exhausted fluid supply	Refill and reprime, or flush
	Clogged fluid lines, hoses, valves, etc.	Clear*
	Loose packing nut or worn packings	Tighten; replace

\* Follow the **Pressure Relief Procedure**, and disconnect the fluid line. If the pump starts when the air is turned back on, the fluid line, hose, valve, etc. was clogged.



# Notes

---

---

---

---

---

---

---

---

---

---

---

---

---

---

---

---

---

---

---

---

---

---

---

---

---

---

# Service

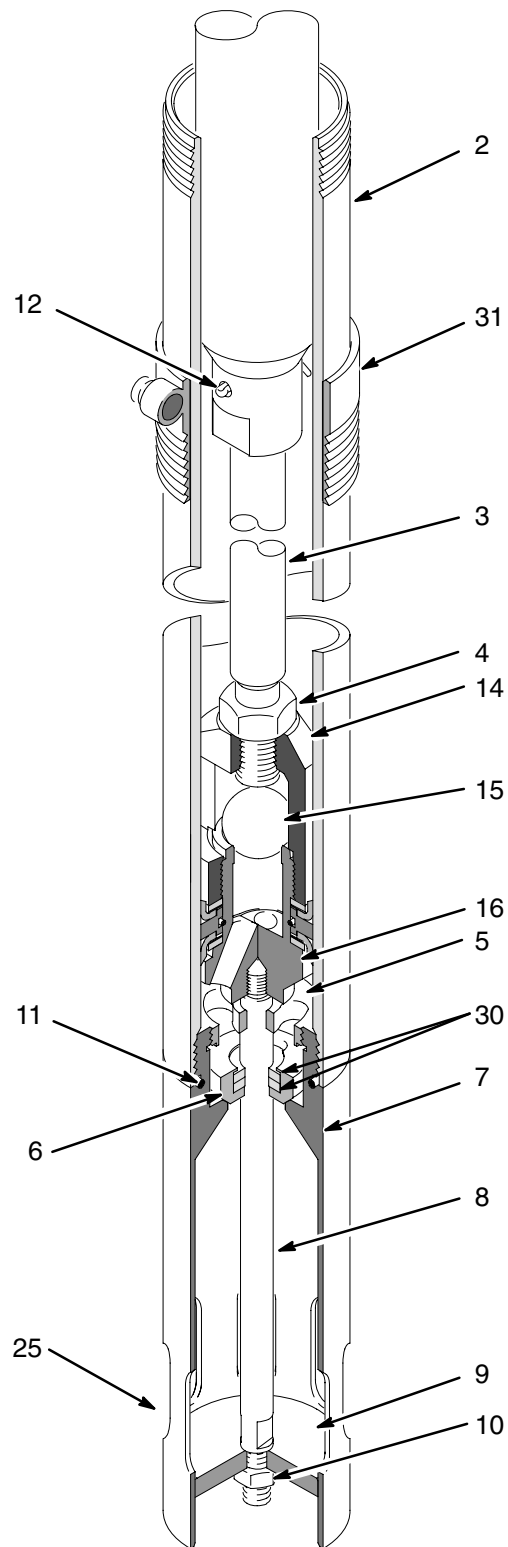

Fig. 3

T12148A

# Service

## Displacement Pump Repair

### **WARNING**

To reduce the risk of serious injury whenever you are instructed to relieve pressure, always follow the **Pressure Relief Procedure** on page 7.

#### *Before you start:*

- To reduce down time, be sure you have all necessary repair parts available.
- Repair Kit 237498 is available. If you have a repair kit, use all the new parts for the best results. Parts included in the kit are marked with an asterisk (\*).
- When cleaning parts, use a compatible solvent. Inspect parts for wear or damage and replace as necessary. Scoring or irregular surfaces on the priming rod (8) or polished inner wall of the riser tube (2) causes premature packing wear and leaking. Check these parts by rubbing a finger on the surface and by holding the parts up to the light at a slight angle.

Use light, waterproof grease wherever grease is mentioned.

### **Disassembly**

1. Follow the **Pressure Relief Procedure** on page 7.
2. Remove nut (10) and priming plate (9) from priming rod (8).
3. Unscrew the foot valve housing (7) from cylinder (2).  
**NOTE:** Poppet check (6) foot valve packings and bearings (5) slide off priming rod (8) when removing foot valve housing.
4. Unscrew bearing (5) from foot valve (7).
5. Remove the poppet check (6) and inspect foot valve packings (30).
6. Unscrew riser tube (2) from pump base. Clean the tube and inspect it for wear by holding it up to a light at a slight angle. If you see wavy lines or scratches where the piston travels, replace the tube as it will not seal well with the new piston packings and the pump will perform poorly.
7. Loosen the lock nut (4) and unscrew the valve housing (14) from the connecting rod (3), unscrew valve housing (14) from piston housing (16).

8. Remove washers (35\*), spreaders (34\*), cup packings (36\*), o-ring (33\*), and cup spacer (20) from the piston housing (16).
9. Clean and inspect all the parts.

### **Reassembly**

1. Reassemble the piston, using all the new parts from the kit and any other new parts needed. Oil the leather cup packings (36\*) first. Then assemble the parts on the piston housing (16) in this order: backup washer (35\*), spreader (34\*), leather packing (36\*), cup spacer (20) with new o-ring (33\*) installed in it, another leather packing (36\*), spreader (34\*), and backup washer (35\*).  
**NOTE:** To replace the throat packings, follow the procedure given in your separate air motor manual (306982) before continuing with the procedure.
2. Screw the piston assembly onto the connecting rod (3) and adjust the ball travel as instructed in **Check Valve Adjustment** on page 12. Tighten the locknut (4).
3. Check the o-ring (13) in the pump base and replace it, if necessary.
4. Lubricate the piston packings and the inner wall at the top of the riser tube (2). Wrap the packings with a guide collar made of 1/64 in. maximum thickness shim stock or metal sheeting. Using a turning motion, work the first leather packing into the riser tube. Remove the guide collar and push the riser tube up and screw it into the base. Torque the tube to 100–150 ft.-lb. (135–204 N-m).
5. Slide bearing (5) onto priming rod (8) with the step side facing the bottom of the pump.
6. Insert foot valve packings (30) into poppet check (6) replace if necessary.
7. Slide poppet check containing foot valve packings onto priming rod (8) with beveled edge facing the bottom of the pump.
8. Slide foot valve over poppet check and screw bearing (5) into the foot valve (7).
9. Push foot valve up to the riser tube.
10. Inspect o-ring (11) for damage and replace if necessary.
11. Screw foot valve (7) onto riser tube (2).

# Service

12. Slide priming plate (9) (beveled edge up) onto priming rod (8). Screw nut (10) onto priming rod and tighten.
13. Reconnect the pump's ground wire to a true earth ground.

## Check Valve Adjustment

This pump has an adjustable piston ball check.

To change the piston ball travel, loosen the locknut (4). Turn the piston valve housing (14) counterclockwise to increase and clockwise to decrease. Medium viscosity fluids should have a 3/16 in. (5 mm) ball travel. Decreasing the ball travel minimizes surging at stroke changeover; however, too short of ball travel restricts the flow and slows down the pump.



# Parts

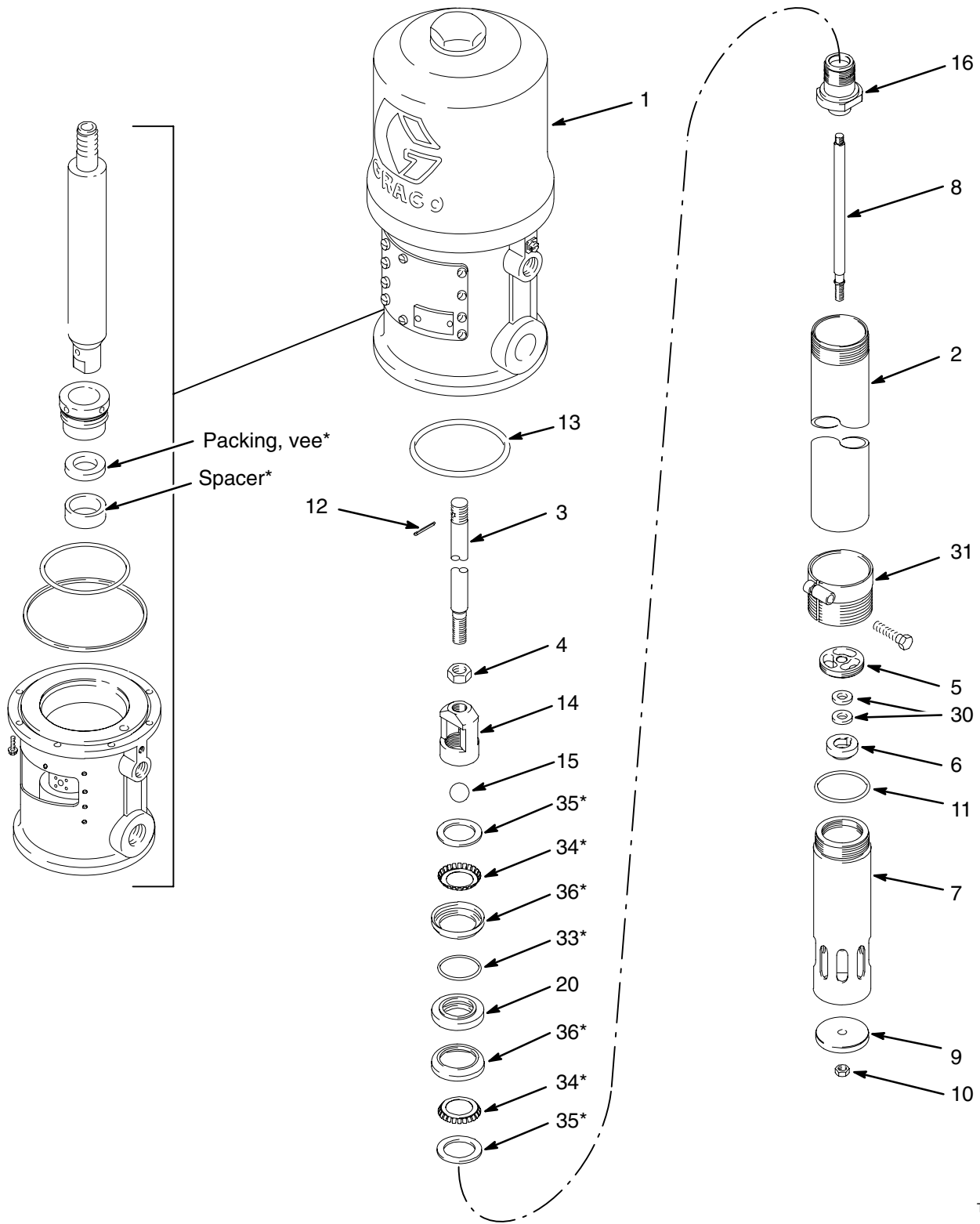

T12147A

# Parts

## Model 965124, Series B stubby length

## Model 965129, Series B 400 lb. (180 Kg) drum length

Ref No.	Part No.	Description	Qty.	Ref No.	Part No.	Description	Qty.
1†		AIR MOTOR	1	30	603778	PACKING, foot valve	2
2	183010	CYLINDER, pump, displacement (model 965124 only)	1	31	222308	ADAPTER, bung; 2 in. npt (model 965129 only)	1
	160917	CYLINDER, pump, displacement (model 965129 only)	1	33*	154662	O-RING	1
3	624936	ROD, connecting (for 965124)	1	34*	171590	SPREADER, cup	2
	624952	ROD, connecting (for 965129)	1	35*	171594	WASHER, piston	2
4	100111	NUT	1	36*	158402	CUP; leather	2
5	624943	BEARING, rod guide, 10:1 shovel	1	* These parts are included in Repair Kit 237498, which may be purchased separately.			
6	624938	POPPET, foot valve	1	† See Graco Manual 306982 to order replacement air motor parts. Air motor 205647 is identical to the one on 965124 and 965129 with the following exceptions:			
7	624935	VALVE, foot	1				
8	624937	ROD, priming	1				
9	624939	PLATE, priming; aluminum	1				
10	100077	NUT, hex	1				
11	156633	O-RING	1	<b>205647</b>			
12	100103	PIN, cotter	1	<b>Ref</b>			
13	156641	O-RING	1	<b>No.</b>	<b>Part No.</b>	<b>Description</b>	
14	624941	HOUSING, valve	1	32	15E954	CYLINDER, motor, air	
15	100279	BALL, metallic	1	34	15F982	BASE, motor, air	
16	624942	HOUSING, valve piston	1	36	15E555	PLATE, identification	
20	158857	SPACER, cup	1	53	116343	SCREW, ground	
				54	omitted	NO WASHER, tab	

# Dimensions

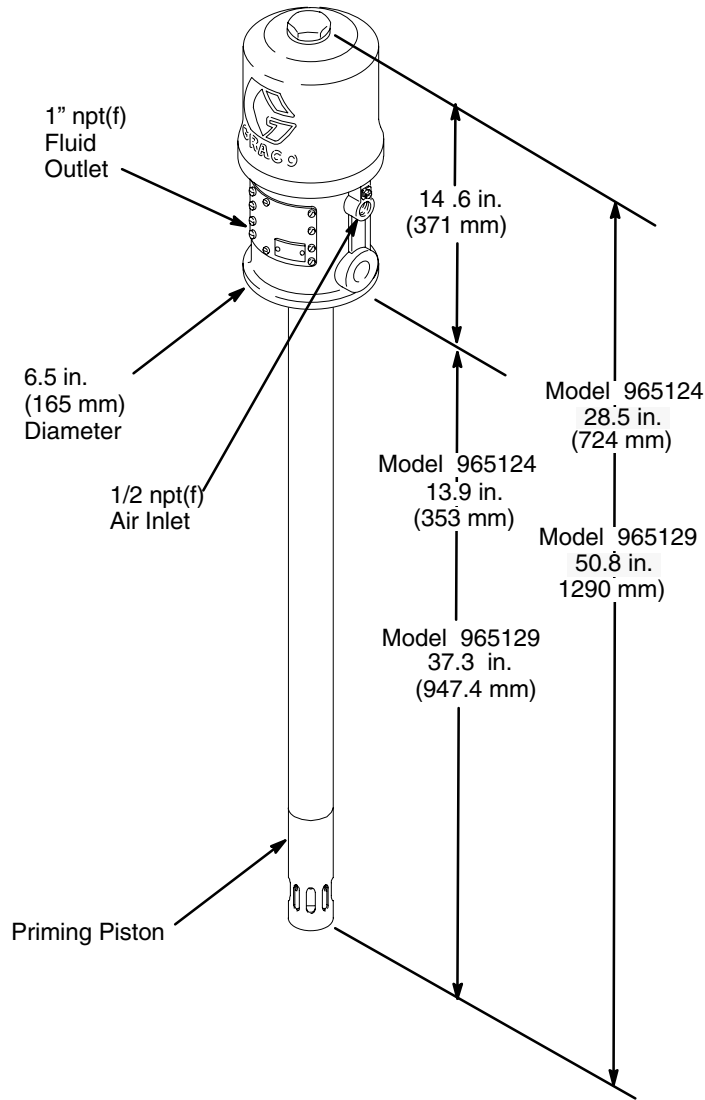

T12146A

# Mounting Hole Layout

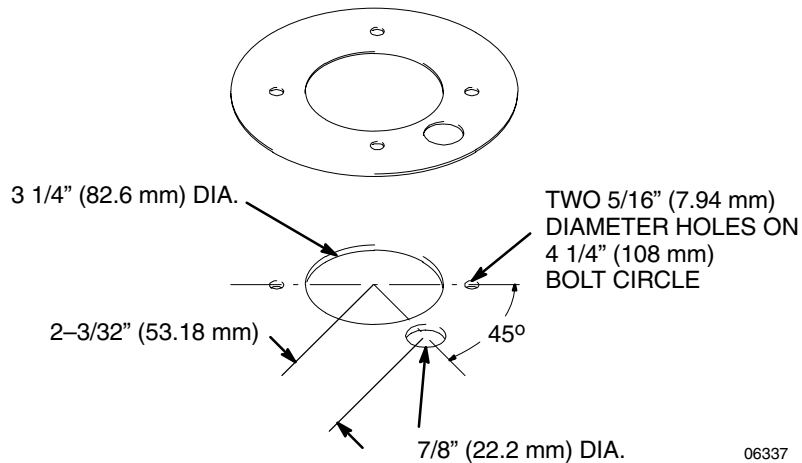

06337



# Technical Data

Fluid pressure ratio .....	10:1
Air pressure operating range .....	40–180 psi (0.3–1.2 MPa, 3–12.4 bar)
Maximum working pressure .....	1800 psi (12.4 MPa, 124 bar)
Maximum delivery .....	5.2 gpm (19.7 lpm)
Cycles per gallon (per liter) .....	20 (6)
Max. recommended pump speed .....	60 cycles per minute
Air motor effective diameter .....	4.25 in (108 mm)
Stroke .....	4 in. (102 mm)
Air consumption .....	approx. 13 cfm per gallon (6 m <sup>3</sup> /hr/liter) of fluid at 100 psi (0.7 MPa, 7 bar)
Wetted parts .....	steel, brass, aluminum, leather, Buna–N
Weight .....	38 lb (17 kg)

## Sound Pressure Level

(measured at 1 meter from unit)

Input Air Pressures at 15 cycles per minute		
<b>40 psi (0.28 MPa, 2.8 bar)</b>	<b>70 psi (0.48 MPa, 4.8 bar)</b>	<b>100 psi (0.7 MPa, 7 bar)</b>
73.6 dB(A)	78.34 dB(A)	80.85 dB(A)

## Sound Power Level

(tested in accordance with ISO 9614–2)

Input Air Pressures at 15 cycles per minute		
<b>40 psi (0.28 MPa, 2.8 bar)</b>	<b>70 psi (0.48 MPa, 4.8 bar)</b>	<b>100 psi (0.7 MPa, 7 bar)</b>
87.4 dB(A)	92.09 dB(A)	94.62 dB(A)

# Graco Standard Warranty

Graco warrants all equipment manufactured by Graco and bearing its name to be free from defects in material and workmanship on the date of sale to the original purchaser for use. With the exception of any special, extended, or limited warranty published by Graco, Graco will, for a period of twelve months from the date of sale, repair or replace any part of the equipment determined by Graco to be defective. This warranty applies only when the equipment is installed, operated and maintained in accordance with Graco's written recommendations.

This warranty does not cover, and Graco shall not be liable for general wear and tear, or any malfunction, damage or wear caused by faulty installation, misapplication, abrasion, corrosion, inadequate or improper maintenance, negligence, accident, tampering, or substitution of non-Graco component parts. Nor shall Graco be liable for malfunction, damage or wear caused by the incompatibility of Graco equipment with structures, accessories, equipment or materials not supplied by Graco, or the improper design, manufacture, installation, operation or maintenance of structures, accessories, equipment or materials not supplied by Graco.

This warranty is conditioned upon the prepaid return of the equipment claimed to be defective to an authorized Graco distributor for verification of the claimed defect. If the claimed defect is verified, Graco will repair or replace free of charge any defective parts. The equipment will be returned to the original purchaser transportation prepaid. If inspection of the equipment does not disclose any defect in material or workmanship, repairs will be made at a reasonable charge, which charges may include the costs of parts, labor, and transportation.

**THIS WARRANTY IS EXCLUSIVE, AND IS IN LIEU OF ANY OTHER WARRANTIES, EXPRESS OR IMPLIED, INCLUDING BUT NOT LIMITED TO WARRANTY OF MERCHANTABILITY OR WARRANTY OF FITNESS FOR A PARTICULAR PURPOSE.**

Graco's sole obligation and buyer's sole remedy for any breach of warranty shall be as set forth above. The buyer agrees that no other remedy (including, but not limited to, incidental or consequential damages for lost profits, lost sales, injury to person or property, or any other incidental or consequential loss) shall be available. Any action for breach of warranty must be brought within two (2) years of the date of sale.

Graco makes no warranty, and disclaims all implied warranties of merchantability and fitness for a particular purpose in connection with accessories, equipment, materials or components sold but not manufactured by Graco. These items sold, but not manufactured by Graco (such as electric motors, switches, hose, etc.), are subject to the warranty, if any, of their manufacturer. Graco will provide purchaser with reasonable assistance in making any claim for breach of these warranties.

In no event will Graco be liable for indirect, incidental, special or consequential damages resulting from Graco supplying equipment hereunder, or the furnishing, performance, or use of any products or other goods sold hereto, whether due to a breach of contract, breach of warranty, the negligence of Graco, or otherwise.

## **FOR GRACO CANADA CUSTOMERS**

The parties acknowledge that they have required that the present document, as well as all documents, notices and legal proceedings entered into, given or instituted pursuant hereto or relating directly or indirectly hereto, be drawn up in English. Les parties reconnaissent avoir convenu que la rédaction du présente document sera en Anglais, ainsi que tous documents, avis et procédures judiciaires exécutés, donnés ou intentés à la suite de ou en rapport, directement ou indirectement, avec les procédures concernées.

## Graco Information

**TO PLACE AN ORDER**, contact your Graco distributor, or call one of the following numbers to identify the distributor closest to you:

**1-800-533-9655 Toll Free**

**612-623-6928**

**612-378-3590 Fax**

*All written and visual data contained in this document reflects the latest product information available at the time of publication.  
Graco reserves the right to make changes at any time without notice.*

This manual contains English. MM 309407

**Graco Headquarters:** Minneapolis

**International Offices:** Belgium, Korea, China, Japan

**GRACO INC. P.O. BOX 1441 MINNEAPOLIS, MN 55440-1441**

**www.graco.com**

09/2002, Revised 10/2011