

REACTOR™

309574P

EN

Electric, Heated, Plural Component Proportioner

For spraying polyurethane foam and polyurea coatings. For professional use only.

Not approved for use in European explosive atmosphere locations.



Important Safety Instructions

Read all warnings and instructions in this manual.
Save these instructions.

See page 2 for Table of Contents and page 3 for List of Models.

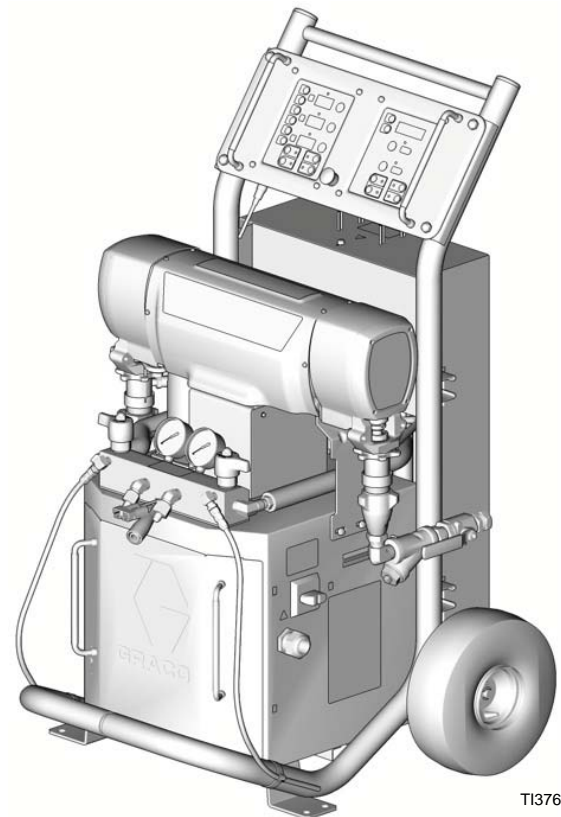

T13764a-1



Contents

Models	3	Parts	53
Supplied Manuals	4	Reactor Assembly	55
Related Manuals	5	Common Parts	55
Warning	6	Parts that Vary by Model	56
Before Beginning Repair	8	248669 Conversion Kit	72
Flushing	8	Technical Data	73
Pressure Relief Procedure	9	Graco Standard Warranty	74
Temperature Control Diagnostic Codes	10	Graco Information	74
E01: High fluid temperature	10		
E02: High hose current	11		
E03: No hose current	11		
E04: Fluid Temperature Sensor (FTS) or "A" or "B" thermocouple not connected.	13		
E05: Board overtemperature	14		
Motor Control Diagnostic Codes	15		
Alarms	15		
Warnings	15		
E21: No component A transducer	16		
E22: No component B transducer	16		
E23: High pressure	16		
E24: Pressure Imbalance	16		
E25: High line voltage	18		
E26: Low line voltage	18		
E27: High Motor Temperature	18		
E28: High current in motor	18		
E29: Brush Wear	19		
Communication Diagnostic Codes	19		
E30: Momentary loss of communication	19		
E99: Loss of communication	19		
Troubleshooting	20		
Repair	24		
Pump Removal	24		
Pump Installation	26		
Drive Housing	28		
Motor Brushes	30		
Circuit Breaker Module	32		
Electric Motor	33		
Motor Control Board	34		
Transducers	36		
Temperature Control Board	38		
245979 Temperature Control Board	39		
Heater	40		
Heated Hose	43		
Fluid Temperature Sensor (FTS)	44		
Display Module	50		

Models

E SERIES

Part No., Series	Model	Voltage (phase)	Full Load Peak Amps*	System Watts**	Heater Watts	Flow lb/min (kg/min)	Output per Cycle (A + B) gal. (liter)	Maximum Fluid Working Pressure psi (MPa, bar)
246025, D	E-20	230V (1)	48	11,100	6,000	20 (9)	.0104 (.0395)	2000 (14, 140)
246026, C	E-30	230V (1)	78	17,900	10,200	30 (13.5)	.0272 (0.1034)	2000 (14, 140)
246030, D	E-20	380V (3)	24	11,100	6,000	20 (9)	.0104 (.0395)	2000 (14, 140)
246031, C	E-30	380V (3)	34	17,900	10,200	30 (13.5)	.0272 (0.1034)	2000 (14, 140)
246034, D	E-20	230V (3)	32	11,100	6,000	20 (9)	.0104 (.0395)	2000 (14, 140)
246035, C	E-30	230V (3)	50	17,900	10,200	30 (13.5)	.0272 (0.1034)	2000 (14, 140)
248657, A	E-30 with 15.3kW	230V (1)	100	23,000	15,300	30 (13.5)	.0272 (0.1034)	2000 (14, 140)
248658, A	E-30 with 15.3kW	230V (3)	62	23,000	15,300	30 (13.5)	.0272 (0.1034)	2000 (14, 140)
248659, A	E-30 with 15.3kW	380V (3)	35	23,000	15,300	30 (13.5)	.0272 (0.1034)	2000 (14, 140)

E-XP SERIES

Part No., Series	Model	Voltage (phase)	Full Load Peak Amps*	System Watts**	Heater Watts	Flow gpm (lpm)	Output per Cycle (A + B) gal. (liter)	Maximum Fluid Working Pressure psi (MPa, bar)
246024, C	E-XP1	230V (1)	69	15,800	10,200	1 (3.8)	.0104 (.0395)	2500 (17.2, 172)
246028, C	E-XP2	230V (1)	100	23,000	15,300	2 (7.6)	.0203 (.0771)	3500 (24.1, 241)
246029, C	E-XP1	380V (3)	24	15,800	10,200	1 (3.8)	.0104 (.0395)	2500 (17.2, 172)
246032, C	E-XP2	380V (3)	35	23,000	15,300	2 (7.6)	.0203 (.0771)	3500 (24.1, 241)
246033, C	E-XP1	230V (3)	43	15,800	10,200	1 (3.8)	.0104 (.0395)	2500 (17.2, 172)
246036, C	E-XP2	230V (3)	62	23,000	15,300	2 (7.6)	.0203 (.0771)	3500 (24.1, 241)

* Full load amps with all devices operating at maximum capabilities. Fuse requirements at various flow rates and mix chamber sizes may be less.

** E-20 and E-XP1 with 210 ft (64.1 m) hose; E-30 and E-XP2 with 310 ft (94.6 m) hose.

Supplied Manuals

The following manuals are shipped with the Reactor™ Proportioner. Refer to these manuals for detailed equipment information.

Order Part No. 15B535 for a compact disk of Reactor manuals translated in several languages.

Reactor Electric Proportioner	
Part No.	Description
309551	Reactor Electric Proportioner, Operation Manual (English)
309577	Displacement Pump, Repair-Parts Manual (English)
Reactor Electrical Diagrams (one of the following is included)	
Part No.	Description
309726	Electrical Diagrams, E-XP1 and E-20, 230V, 1 phase
309727	Electrical Diagrams, E-XP2 and E-30, 230V, 1 phase
309728	Electrical Diagrams, E-XP1 and E-20, 380V, 3 phase
309729	Electrical Diagrams, E-XP2 and E-30, 380V, 3 phase
309730	Electrical Diagrams, E-XP1 and E-20, 230V, 3 phase
309731	Electrical Diagrams, E-XP2 and E-30, 230V, 3 phase

Related Manuals

The following manuals are for accessories used with the Reactor™.

Order Part No. 15B381 for a compact disk of Fusion manual translated in several languages.

Order Part No. 15B535 for a compact disk of Reactor manuals translated in several languages.

Feed Pump Kits	
Part No.	Description
309815	Instruction-Parts Manual (English)
Air Supply Kit	
Part No.	Description
309827	Instruction-Parts Manual (English) for Feed Pump Air Supply Kit
Circulation and Return Tube Kits	
Part No.	Description
309852	Instruction-Parts Manual (English)
Heated Hose	
Part No.	Description
309572	Instruction-Parts Manual (English)
Fusion Air Purge Spray Gun	
Part No.	Description
309550	Instruction-Parts Manual (English)
Fusion Mechanical Purge Spray Gun	
Part No.	Description
309856	Instruction-Parts Manual (English)
Circulation Kit	
Part No.	Description
309818	Instruction-Parts Manual (English)
Data Reporting Kit	
Part No.	Description
309867	Instruction-Parts Manual (English)
Pump Wet-Cup Flush Kits and Reservoir Kit	
Part No.	Description
309911	Instruction-Parts Manual (English)
Transformer Repair Kit	
Part No.	Description
309930	Instruction-Parts Manual (English)
Rupture Disk Assembly Kit	
Part No.	Description
309969	Instruction-Parts Manual (English)

WARNING
**SKIN INJECTION HAZARD**





High-pressure fluid from gun, hose leaks, or ruptured components will pierce skin. This may look like just a cut, but it is a serious injury that can result in amputation. **Get immediate surgical treatment.**

- Do not point the gun at anyone or at any part of the body.
- Do not put your hand or fingers over the gun fluid nozzle.
- Do not stop or deflect leaks with your hand, body, glove, or rag.
- Do not “blow back” fluid; this is not an air spray system.
- Follow **Technical Data**, page 73, when you stop spraying and before cleaning, checking, or servicing equipment.
- Use lowest possible pressure when flushing, priming, or troubleshooting.
- Engage spray gun piston safety lock when not spraying.
- Tighten all fluid connections before operating the equipment.
- Check hoses, tubes, and couplings daily. Replace worn or damaged parts immediately. High pressure hose cannot be recoupled; replace the entire hose.

**FIRE, EXPLOSION, AND ELECTRIC SHOCK HAZARD**

Solvent and fumes in work area can ignite or explode. High voltage components can cause electric shock. To help prevent fire, explosion, and electric shock:

- Shut off main power switch and wait 5 minutes before opening Reactor cabinet door.
- All electrical wiring must be done by trained and qualified personnel and comply with all local codes.
- Ground equipment and conductive objects. See **Grounding** in the Operation manual.
- Use equipment only in well ventilated area.
- Eliminate all ignition sources, such as pilot lights, cigarettes and plastic drop cloths (potential static arc).
- Do not plug or unplug power cords or turn lights on or off when flammable fumes are present.
- Keep the work area free of debris, including solvent, rags, and gasoline.
- Hold gun firmly to side of grounded pail when triggering into pail.
- Use only grounded hoses.
- If there is static sparking or you feel a shock, **stop operation immediately**. Do not use equipment until you identify and correct the problem.
- To avoid chemical reaction and explosion, do not use 1,1,1-trichloroethane, methylene chloride, other halogenated hydrocarbon solvents or fluids containing such solvents in pressurized aluminum equipment.

 WARNING	
	<p>EQUIPMENT MISUSE HAZARD</p> <p>Misuse can cause serious injury or death.</p> <ul style="list-style-type: none"> • For professional use only. • Use equipment only for its intended purpose. Call your Graco distributor for information. • Read manuals, warnings, tags, and labels before operating equipment. Follow instructions. • Check equipment daily. Repair or replace worn or damaged parts immediately. • Do not alter or modify equipment. Use only Graco parts and accessories. • Do not exceed the maximum working pressure or temperature rating of the lowest rated system component. See Technical Data in all equipment manuals. • Use fluids and solvents that are compatible with equipment wetted parts. See Technical Data in all equipment manuals. Read fluid and solvent manufacturer's warnings. • Route hoses and cables away from traffic areas, sharp edges, moving parts, and hot surfaces. • Do not use hoses to pull equipment. • Comply with all applicable safety regulations.
	<p>BURN HAZARD</p> <p>This equipment is used with heated fluid, which can cause equipment surfaces to become very hot. To avoid severe burns:</p> <ul style="list-style-type: none"> • Do not touch hot fluid or equipment. • Allow equipment to cool completely before touching it. • Wear gloves if fluid temperature exceeds 110°F (43°C).
	<p>TOXIC FLUID OR FUMES HAZARD</p> <p>Toxic fluids or fumes can cause serious injury or death if splashed in the eyes or on skin, inhaled, or swallowed.</p> <ul style="list-style-type: none"> • Read Material Safety Data Sheet (MSDS) to know the specific hazards of the fluids you are using. • Store hazardous fluid in approved containers, and dispose of it according to applicable guidelines.
	<p>PERSONAL PROTECTIVE EQUIPMENT</p> <p>You must wear proper protective equipment when operating, servicing, or when in the operating area of the equipment to help protect you from serious injury, including eye injury; inhalation of toxic fumes; and hearing loss. This equipment includes but is not limited to:</p> <ul style="list-style-type: none"> • Protective eyewear. • Gloves, clothing, and respirator as recommended by the fluid and solvent manufacturer. • Hearing protection.

Before Beginning Repair

WARNING



Repairing this equipment requires access to parts which may cause electric shock or other serious injury if work is not performed properly. Have a qualified electrician connect power and ground to main power switch terminals, see the Operation manual. Be sure to shut off all power to the equipment before repairing.

1. Flush if necessary, see **Flushing**.
2. Park component A pump.

a. Press .

b. Trigger gun until pump A stops. After fluid pressure drops below 700 psi (4.9 MPa, 49 bar), motor will run until component A pump is at bottom of its stroke, then shut off.

c. Check ISO reservoir for component A pump. Fill wet-cup on component B pump. See operation manual.

3. Turn main power OFF .

4. Relieve pressure, page 9.

Flushing

WARNING



Read warnings, page 6. Flush equipment only in a well-ventilated area. Do not spray flammable fluids. Do not turn on heaters while flushing with flammable solvents.

- Flush out old fluid with new fluid, or flush out old fluid with a compatible solvent before introducing new fluid.
- Use the lowest possible pressure when flushing.
- All fluid components are compatible with common solvents. Use only moisture-free solvents.
- To flush feed hoses, pumps, and heaters separately from heated hoses, set PRESSURE RELIEF/SPRAY valves (SA, SB) to PRESSURE RELIEF.

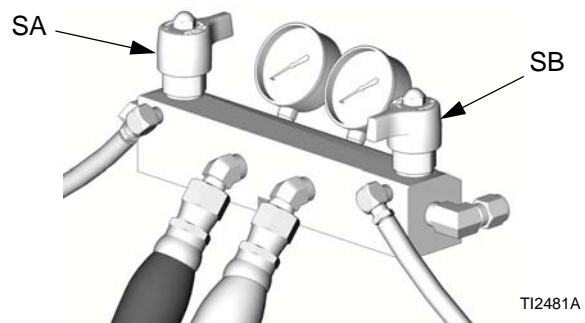

- To flush entire system, circulate through gun fluid manifold (with manifold removed from gun).
- Always leave some type of fluid in system. Do not use water.

Pressure Relief Procedure

1. Relieve pressure in gun and perform gun shutdown procedure. See gun manual.
2. Verify gun fluid manifold valves A and B are closed.

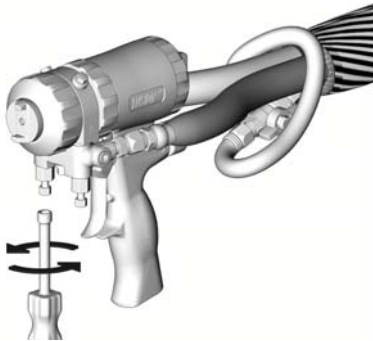

TI2421A

3. Shut off feed pumps and agitator, if used.

4. Turn PRESSURE RELIEF/SPRAY valves (SA, SB) to PRESSURE RELIEF. Route fluid to waste containers or supply tanks. Ensure gauges drop to 0.

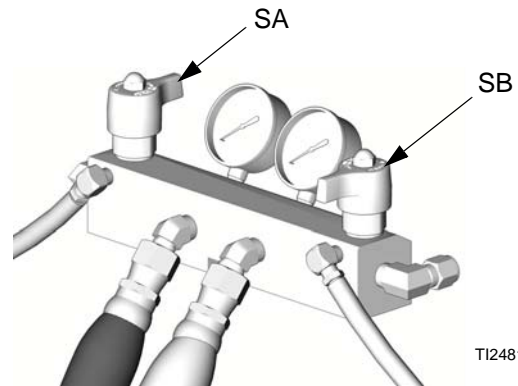

TI2481A

5. Engage gun piston safety lock.



TI2409A

6. Disconnect gun air line and remove gun fluid manifold.

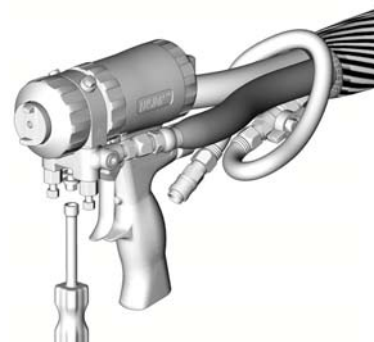

TI2543A

Temperature Control Diagnostic Codes

Temperature control diagnostic codes E01 through E05 appear on temperature display.

These alarms turn off heat. Turn main power OFF

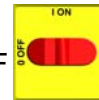

then ON



to clear.

Code No.	Code Name	Alarm Zone	Corrective Action page
01	High fluid temperature	Individual	10
02	High hose current	Hose only	11
03	No hose current with hose heater on	Hose only	11
04	FTS or thermocouple not connected	Individual	13
05	Board overtemperature	All	14

 For hose zone only, if FTS is disconnected at startup, display will show hose current 0A.

E01: High fluid temperature

- Using an external temperature-sensing device, check to see if you really do have high temperatures.
- Check connections between temperature control board and heater overtemperature switches, page 42.
- Make sure all of the wires are securely connected into connector J1.
- Check temperature sensors, page 41.
- Check temperature sensor is contacting heater element, page 41.

If you do not have high temperature (A temp reading below 190° F):

- Make sure connector J1 is firmly plugged into the heater control board.
- Check continuity of the over-temperature switches and the "A" and "B" temperature sensors by removing the J1 plug from the temperature control board socket. On the plug end check the resistance:

Pins 1 & 2	~ 0 Ω
Pins 3 & 4	~ 0 Ω
Pins 7 & 8	4 - 6 Ω
Pins 10 & 11	4 - 6 Ω

If you do have a high temperature:

- Note what zone ("A", "B", or both) is exhibiting the high temperature condition.
 -  You will need to cool the unit down to be able to do any testing. Using your feed pumps to move cool material into the Reactor can do this.
- Check resistance of the "A" and "B" temperature sensors. Remove the J1 plug from the temperature control board socket. Refer to Table 4, page 38. Resistance across pins 7 and 8 = 4 - 6 ohms. Resistance across pins 10 and 11 = 4 - 6 ohms.
- Check temperature sensor is contacting heater element, page 41.
- Check if the heater control board turns off when the unit hits the set point temperature.

- With power off, remove the wire nuts on the back of the unit leading to the heater, attach the leads of an A/C volt meter to the wires, and tape them off so they can't be touched or shorted.
- Set the "A" and "B" set point below the ambient temperature, and turn the heat zones on. The red light above each zone should blink and the voltmeter should read little to no voltage. Measuring line voltage while the red light is blinking would indicate that the relay on the heater control board has failed. In this case, replace the heater control board.

E02: High hose current

1. Check tap connection at transformer, see operation manual.
2. Check hose connections for electrical short, page 43.
3. Move to lower hose length on transformer.
4. Replace temperature control board, page 38.

E03: No hose current

 Check transformer. If transformer has “lollipops” located in front, refer to E03 (lollipops). If the transformer does not include the “lollipops,” refer to E03 (no lollipops).

E03 (lollipops)

Do all of the steps in order with out skipping any steps. If you don't you may misdiagnose the failure.

1. Check hose connectors for broken electrical connection, page 43.
2. With the main power off, and the hose plugged in, test the continuity of the heated hose through the Reactor unit. Pull connector J13 off of the temperature control board and remove the red wire from the transformer hose length tap. Perform a continuity measurement between pin 6 of the **J13 wire harness** (not the board) and the wire removed from the transformer tap. You should have continuity. If no continuity exists, trace the wires until you find the problem. See FIG. 1.

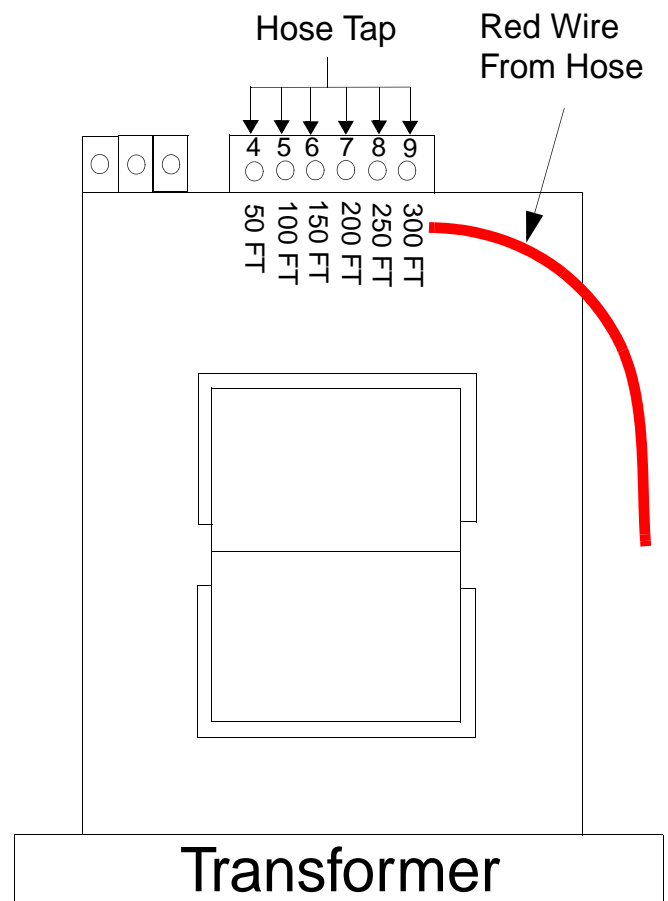
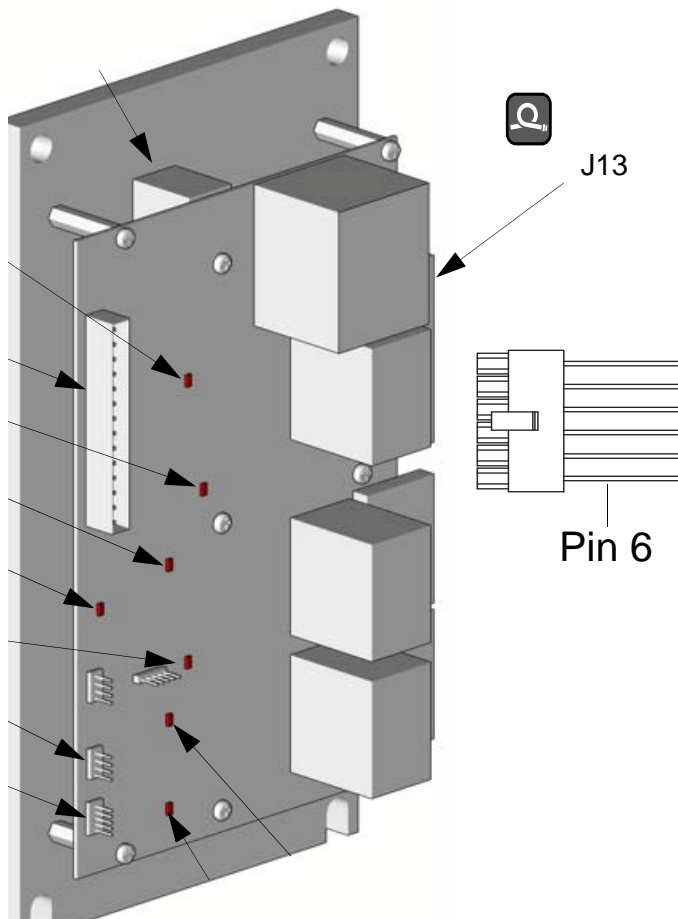

FIG. 1

3. With the main power off, the hose plugged in, and wire harness from the connector J13 still removed from the temperature control board:
 - a. Check for continuity between Pin 1 on the J13 harness, and the bottom of the left 20-amp hose breaker. See FIG. 2.
 - b. Check for continuity between Pin 2 on the J13 harness, and one of the leads of the black In-rush limiter located on the upper left hand side the transformer.
 - c. Check for continuity between Pin 3 on the J13 harness, and the bottom of the right 20-amp hose breaker.
 - d. Check for continuity between Pin 4 on the J13 harness, and the opposite lead of the black In-rush limiter from step b, located on the upper left hand side the transformer.
 - e. Check for continuity between Pin 5 on the J13 harness, and the bottom of the 50-amp hose breaker.

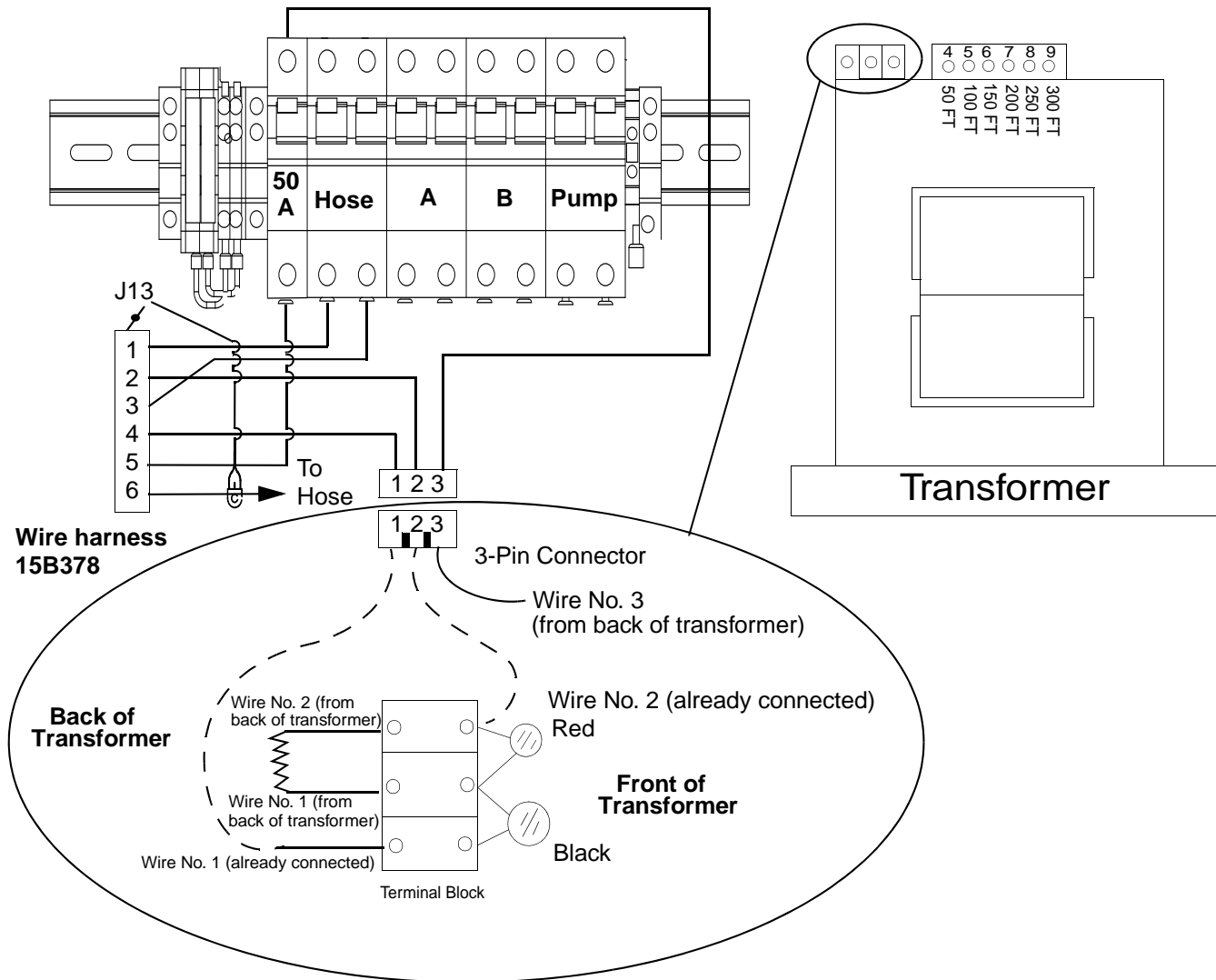

FIG. 2

4. Check 50A (806) and 20A (817A) circuit breakers, page 32.
5. Test current sensor continuity, page 46.
6. With the main power off, test the In-rush current limiter (“black lollipop”), by doing a continuity measurement across the two leads on the In-rush limiter, located on the left hand side of the transformer. See FIG. 3. (There are two different orientations of the In-rush limiter, both located on the left hand side of the transformer). You should have continuity; generally the measurement should read between 5 – 20 ohms. If you don’t have continuity, the In-rush current limiter bad – replace the In-rush limiter.

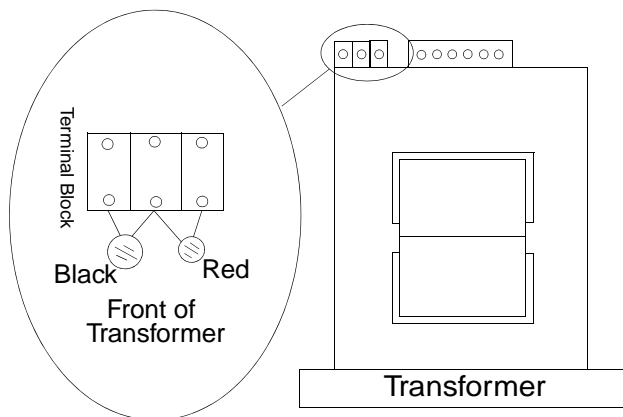

FIG. 3

7. Complete Transformer Primary check:
 - a. Make sure everything is reconnected, **including the hose**.
 - b. Turn the main power on.
 - c. Adjust the hose heat set point below the ambient hose temperature.
 - d. Turn the hose heat on.

WARNING



Read warnings, page 6. Step e measures line voltage and should be done by a qualified electrician. If work is not performed properly it may cause electric shock or other serious injury.

- e. **Carefully** measure the voltage across the two wires of the red surge suppressor.

If you do not measure line voltage, the Temperature Control Board is bad – replace the Temperature Control Board.

8. Complete **Transformer Secondary Check**, page 49.
9. Perform SCR circuit check, page 44.

E03 (no lollipops)

Do steps in order. Do not skip any step.

1. Check 50A (806) and 20A (817A) circuit breakers, page 32.
2. Check hose connectors for broken electrical connection, page 43.
3. Do **Transformer Secondary Check**, page 48.
4. Test wire harness continuity.
5. Test complete hose continuity, page 43.
6. Test temperature control board to transformer wire harness continuity, page 38.
7. Test transformer wire harness continuity, page 46.
8. Test current sensor continuity, page 46.
9. (380 V Only) Do In-rush current limiter check, page 46.
10. Do **Transformer Primary Check**, page 48.
11. Perform SCR circuit check, page 44.

E04: Fluid Temperature Sensor (FTS) or “A” or “B” thermocouple not connected.



The display that is showing the E04 error is the zone that is seeing the error.

“A” and “B” side thermocouple assemblies:

1. Check the electrical connections at the temperature control board. Refer to Table 4, page 38 and Figure 10, page 35.

- a. Remove plug J1 (Green 14-pin terminal block) from the temperature control board and make sure all pins are securely connected.
2. Check the "A" and "B" thermocouples by removing the J1 connector from the temperature control board and check the pins with an ohmmeter.
 - a. "A" thermocouple:
 - With J1 disconnected measure the resistance across pins 7 and 8. It should measure 4 - 6 Ohms. If not, replace the "A" thermocouple.
 - Measure the resistance between Pin 7 and the thermocouple housing. Measure the resistance between Pin 8 and the thermocouple housing. It should be infinity, if not replace the "A" thermocouple.
 - b. "B" thermocouple:
 - With J1 disconnected measure the resistance across pins 10 and 11. It should measure 4 - 6 Ohms. If not, Replace the "B" thermocouple.
 - Measure the resistance between Pin 10 and the thermocouple housing. Then measure between Pin 11 and the thermocouple housing. It should read infinity. If not replace the "B" thermocouple.

FTS:

1. Check FTS operation by connecting directly to Reactor.
 - a. Locate the FTS.
 - b. Unplug the FTS electrical connection.
 - c. Plug the Reactor end of the connector directly into the FTS electrical connector.
2. Check cable connections between all hose lengths.
3. Check temperature sensor connection at J1 on temperature control board, page 38. Ensure pins 12, 13 and 14 are connected properly.
4. Check the FTS with an ohmmeter, page 44.
5. Use manual current control mode; see operation manual.
6. Check FTS operation by connecting directly to Reactor.
7. Check cable connections between all hose lengths.

8. Check temperature sensor connection at J1 on temperature control board, page 38.
9. Check thermocouple, page 41. Check FTS, page 44.
10. Use manual current control mode; see operation manual.

E05: Board overtemperature



The circuit board has it's own temp sensor. If it sees the circuit board getting too hot (80°C for >42ms/50ms), it will shut down.

1. Check fan operation.
2. Check electrical cabinet door is properly installed.
3. Check for obstructions blocking cooling holes in bottom of Reactor.
4. Ambient temperature too high. Reduce gun mix chamber size, or move Reactor to a cooler location.

Motor Control Diagnostic Codes

Motor control diagnostic codes E21 through E29 appear on pressure display.

There are two types of motor control codes: alarms and warnings. Alarms take priority over warnings.

 Alarms can also be cleared, except for code 23, by pressing .

Alarms

Alarms turn off Reactor. Turn main power OFF  then

ON  to clear.

Warnings

Reactor will continue to run. Press  to clear. A warning will not recur for a predetermined amount of time (varies for different warnings), or until main power is turned OFF

 then ON .

Code No.	Code Name	Alarm (A) or Warning (W)	Corrective Action page
21	No transducer (component A)	A	16
22	No transducer (component B)	A	16
23	High pressure	A	16
24	Pressure imbalance	A/W (to select, see page 34)	16
25	High line voltage	A	18
26	Low line voltage	A	18
27	High motor temperature	A	18
28	High current	A	18
29	Brush wear	W	19
99	Communication Error 2		

E21: No component A transducer

1. Check transducer A connection at J3 on the motor control board, page 35.
2. Reverse A and B transducer connections. If error moves to transducer B (E22), replace transducer A, page 36. If error does not move (stays the same) replace the motor control board.

E22: No component B transducer

- a. Check transducer B connection at J8 for E-20 and E-XP1 or J5 for E-30 and E-XP2 on the motor control board, page 35.
- b. Reverse A and B transducer connections. If error moves to transducer A (E21), replace transducer B, page 36. If error does not move (stays the same) replace the motor control board.

E23: High pressure



Relieve pressure. Verify low pressure with analog

gauges. Turn main power OFF  then ON



. If error persists, do following checks.

1. Check the jumpers and the wiring. Check jumper on motor control board J10 for E20 and E-XP1, or J7 for E30 and E-XP2, pins 7-10, page 34.
2. Remove, clean and re-install the pressure transducer leads

If the jumpers and the wiring are in good working condition and you still have the error, then you will need to replace the "A" and "B" pressure transducers.

3. To determine if it's the "A" or the "B" transducer, you will need a known good Reactor pressure transducer to use as a "test" transducer. The test is done

without removing the existing pressure transducers from the fluid manifold.

- a. Unplug the "A" transducer from the Motor control board socket (page 36) and replace with "test" transducer.
 - b. Turn on the Reactor master power.
 - If the error is gone, turn off the Reactor main power, remove test transducer, and replace "A" transducer.
 - If the error persists, unplug the "test" transducer from the "A" socket, and reinstall the "A" pressure transducer back into the "A" socket. Repeat this test procedure on the "B" side.
4. If the error persists and no root cause is found through the above testing, replace the motor control board, page 34.

E24: Pressure Imbalance

Pressure Imbalance: There is a pressure difference between the "A" and "B" fluids of more than 50% of the set point pressure.

"Fast" E24:

- Pump zone is turned on, E24 within 5 - 10 seconds.
- E24 during trigger actuation (pressures are balanced otherwise).

If gauge pressures are very close

1. Clear the error and run the unit.
2. Check plug J10 (E20/E-XP1) or J7 (E30/E-XP2) or the jumpers 7 to 8, or 9 to 10 on the motor control board.
3. Check pressure transducer performance:

The digital display on a Reactor always shows the higher of the two pressures. As soon as the higher analog pressure drops below the lower analog pressure the digital display will switch to the new highest reading. Determine which transducer is performing poorly.

1. For testing purposes only, find the dip switches labeled SW2 on the motor control board, page 35. Set dipswitch 3 to OFF. This will allow the Reactor to run with a pressure imbalance alarm.

2. Run the unit to build up some pressure (1000 – 1200 psi). Shut down the unit, clear the alarm and power back up. Do not depressurize the unit.
3. Check the analog gauges to see which pressure is higher. Check if the display pressure matches, indicating that the motor control board “sees” that transducer. If not, the motor control board does not “see” that transducer. Check the wire connections and or replace the transducer.
4. With the pump zone off, use the pressure relief valves to slowly relieve the “high” side pressure, while watching the digital display and the analog gauges. Once the higher analog gauge drops below the lower analog pressure the motor control board should start reading the “new” high side pressure (because it is now the higher of the two). Continue dropping the original “high” side pressure - the digital display should stop dropping. Repeat the process to check the other pressure transducer.

The last test determines if the pressure transducer has failed or if the socket on the pressure control board has gone bad.

1. Swap the transducer plug-ins on the motor control board. (J3 and J8 for the E-20 and E-XP1. J3 and J5 for the E30 and E-XP1).
2. Repeat above test.
3. If the problem stays with the same side as before, then the pressure transducer is bad.
4. If the problem switches to the other transducer, then the problem is in the motor control boards socket.

If the gauge readings are *not* equal.

1. Clear the error and balance the pressures using the dump valves.
2. If you cannot get the pressures to balance:
 - Check for pump failure.
 - Check for adequate material.
 - Using the feed pump to push fluid out through the gun manifold, check for a plugged fluid path.
 - Run the unit.
 - Check and clean the gun inlet screens.
 - Check and clean the mix chamber “A” and “B” impingement ports as well as the center port. **Note: Some mix chambers have counter bored holes, and require two drill sizes to clean impingement ports completely.**

“Slow” E24:

- When spraying, gradual pressure imbalance and eventual E24.

Possible Causes:

- One side of the Gun is partially blocked.
- The “A” or the “B” pump on the Reactor has failed.
- The “A” or the “B” feed pump has failed.
- The “A” or the “B” feed pump pressure is set too high.
- The “A” or the “B” inlet screen is plugged.
- The hose is not heating properly.
- Kinked supply hose.
- Bottom of the drum is damaged causing a blockage to the inlet of the feed pump.
- The drum is not vented properly.

E25: High line voltage

Supply voltage too high. Check Reactor voltage requirements, page 73.

E26: Low line voltage

Supply voltage too low. Check Reactor voltage requirements, page 73.

E27: High Motor Temperature

1. Motor temperature too high. Reduce pressure, gun tip size, or move Reactor to a cooler location. Allow one hour for cooling.
2. Check fan operation.
3. Ensure there is no obstruction around the fan area that would cause lack of airflow; ensure the motor/fan shroud is installed.
4. Ensure the unit is being operated with the front cover on.
5. Ensure the brush wear/over temp switch wire assembly is plugged into J7 (E-20/E-XP1) or J6 (E-30/E-XP2) of the motor control board.
6. With the main power off, unplug the wire harness from J7 (E-20/E-XP1) or J6 (E-30/E-XP2) on the motor control board and install a jumper wire on pins 1 and 2. Turn the main power back on.

If E27 is gone:

If the E27 error is gone and the motor is truly not overheated, then the problem can be in the motor/motor wire harness assembly. Measure the resistance between the two yellow wires that go to pins 1 and 2 of the motor connector. If there is an open connection, the thermal overload switch is open or there is a broken wire inside the motor, or a broken wire in the motor harness.

If the E27 error code is still there, double check if pins 1 and 2 are jumpered properly. If jumpered properly, then it would appear that the problem is with in the motor control board.

E28: High current in motor

Check motor control board:

1. Turn the master power off.
2. Disconnect socket J4 (E-20/E-XP1) J1 (E-30/E-XP2) on the motor control board.
3. Turn the master power back on.
4. If the E28 error did not go away then there is a problem with the motor control board. Replace board, page 34.

Check motor:

1. Check to see if the motor rotates freely.
2. Check to see if the brushes are damage.
3. Check that the voltage going to the motor is good.
4. Check the three wire (yellow, yellow, orange) motor connector to the motor board. A gentle tug on each wire individually at the connector should identify the loose wire. If a wire pulls out, bend the locking tab on the crimp end, insert the wire until it seats and repeat gentle tug.
5. If the above does not resolve the problem, replace the motor, page 33.

E29: Brush Wear

CAUTION

Prolonged operation of motor after a brush wear warning may result in failure of motor and motor control board.

1. Check for normal brush wear, which causes the brush sensor to come in contact with the motor commutator. Replace the brushes, page 30.
2. Check spade plug. The spade plug inside the motor housing may be twisted and contacting the commutator side of the brush sensor assembly, causing a false alarm. Follow the orange wire coming from J7 (E-20/E-XP1), or J6 (E-30/E-XP2), up to the spade connector on the motor. Using a flashlight, ensure the spade plug assembly is **not** making contact with the metal housing of the brush assembly.
3. Check wiring. The yellow brush sensor wire coming out of the brush may be routed online with the commutator wiring (thick red wire), causing a false alarm. Reroute the yellow wire coming out of the brush, away from the commutator wiring.
4. Check motor control board.
 - Remove the plug in J7 (E-20/E-XP1), or J6 (E-30/E-XP2). (This will cause an E27 alarm).
 - To remove the E27 alarm, use a jumper wire on the motor control board, across the two pins that the two yellow wires plug into. Then turn the unit on.
 - The E27 as well as the E29 alarm should be gone. If the E27 alarm is not gone double-check your jumper.
 - If the jumper is installed correctly and the E29 alarm is still there, replace the motor control board, page 34.

Communication Diagnostic Codes

E30: Momentary loss of communication

Communications between the display and the motor control board or the temperature control board have been momentarily lost. Normally, when communication is lost, the corresponding display will show E99. The corresponding control board will register E30 (The red LED will flash 30 times). If communications are reconnected, the display can show the E30 for a small time (no more than about two seconds). It should not be possible for E30 to be shown continuously, unless there is a loose connection causing the display and the board to continuously lose and regain communication.

Check all wiring between the display and the corresponding control board.

E99: Loss of communication

Communications between the display and the motor control board or the temperature control board has been lost. When communication is lost, the corresponding display will show E99.

1. Check all wiring between the display and the corresponding control board. Pay close attention to the wire crimping on plug J13 for each board.

WARNING





Read warnings, page 6. Step 2 measures line voltage and should be done by a qualified electrician. If work is not performed properly it may cause electric shock or other serious injury.



2. Measure the incoming voltage to the board (it should be ~ 230Vac).
3. If it was only receiving 1 leg of the 230Vac the board may light up, and still not function properly. Correct the incoming voltage problem.

Troubleshooting

PROBLEM	CAUSE	SOLUTION
Reactor does not operate.	No power.	Plug in power cord.
		Turn main power ON 
	Red stop button circuit open.	Turn circuit breakers ON, page 32.
Motor does not operate.	Red stop button circuit open.	Check button connections. See page 50 and electrical diagrams.
	Loose connections.	Check connections at motor control board.
	Circuit breaker tripped.	Reset breaker (CB5), page 32. Check 230Vac at output of breaker.
	Worn brushes.	Check both sides. Length must be 0.7 in. (17 mm) minimum. To replace, page 30.
	Broken or misaligned brush springs.	Realign or replace, page 30.
	Brushes or springs binding in brush holder.	Clean brush holder and align brush leads for free movement.
	Shorted armature.	Replace motor, page 33.
	Check motor commutator for burn spots or other damage.	Remove motor. Have motor shop resurface commutator, if possible.
Damaged motor control board.	Replace board. See page 34.	
Fan not working.	Blown fuse.	Replace, page 37.
	Loose wire.	Check.
	Defective fan.	Replace, page 37.
Pump output low.	Obstructed fluid hose or gun; fluid hose ID too small.	Open, clear; use hose with larger ID.
	Worn piston valve or intake valve in displacement pump.	See pump manual.
	Pressure setpoint too high.	Reduce setpoint and output will increase.
Fluid leak in pump packing nut area.	Worn throat seals.	Replace. See pump manual.
No pressure on one side.	Fluid leaking from heater inlet rupture disk (214).	Check if heater (2) and PRESSURE RELIEF/SPRAY valve (SA or SB) are plugged. Clear. Replace rupture disk (214) with a new one; do not replace with a pipe plug.

PROBLEM	CAUSE	SOLUTION
No display.	Main power OFF.	Turn main power ON 
	Loose display cable.	Check cable connections, page 50.
	Both display boards failed.	Check boards, replace; page 50.
No temperature display.	Loose display cable.	Check cable connections, page 50.
	Failed temperature control board.	Open cabinet. Check if board LED is blinking. If not, check power wiring connections to ensure board has power. If board has power and LED is not blinking, replace board, page 38.
	Inadequate power to temperature board.	Check that power supply meets requirements.
	Loose power cable (internal to display).	Check cable connections, page 50.
	Defective display board.	Replace, page 50.
No pressure display.	Loose display cable.	Check cable connections, page 50.
	Failed motor control board.	Open cabinet. Check if board LED is lighted. If not, replace board, page 34.
	Inadequate power to motor control board.	Check that power supply meets requirements.
	Loose power cable.	Check cable connections, page 50.
	Defective display board.	Replace, page 50.
	Circuit breaker tripped.	Reset breaker.
Hose display reads 0A on startup.	FTS not installed and  zone off.	Install FTS (see operation manual), or adjust current to desired setting.
Erratic display; display turns on and off.	Cable not grounded.	Ground cable, page 50.
	Extension cable too long.	Must not exceed 100 ft (30.5 m).
Display buttons do not work properly; cannot get out of an operation.	Broken membrane switch.	Replace, page 50.
	Ribbon cable disconnected or broken.	Connect cable, or replace.
Red stop button does not work.	Broken button (fused contact).	Replace, page 50.
	Loose wire.	Check connections, page 50.

PROBLEM	CAUSE	SOLUTION
No heat in A or B zones.	Circuit breaker(s) tripped.	Reset breaker CB3 or CB4, page 32.
	Heat turned off.	Press A or B zone  keys.
	Temperature control alarm.	Check temperature displays for diagnostic code, page 10.
	Defective heater.	Replace, page 40. Check resistance.
	Loose connectors or wire nuts.	Check connections.
	Failed temperature control board.	Open cabinet. Check if board LED is blinking. If not, check power wiring connections to ensure board has power. If board has power and LED is not blinking, replace board, page 38.
Low heat in A or B zones.	A and B temperature setpoints too low.	Check setpoint. Increase if necessary.
	Flow too high.	Use smaller mix chamber. Decrease pressure.
	Defective heater.	Replace, page 40. Check resistance.
	Loose connectors or wire nuts.	Check connections.
	Low voltage.	Check that power supply meets requirements.
	Overheated temperature control board.	Check fan operation.
		Check if door is open; close.
		Check that cooling holes are not clogged or obstructed.
Fluid too cold.	Preheat fluid.	

PROBLEM	CAUSE	SOLUTION
No hose heat.	Loose hose electrical connections.	Check connections. Repair as necessary.
	Circuit breakers tripped.	Reset breakers (CB1 or CB2), page 32.
	Hose zone not turned on.	Press  zone  key.
	A and B temperature setpoints too low.	Check. Increase if necessary.
	Failed temperature control board.	Open cabinet. Check if board LED is blinking. If not, check power wiring connections to ensure board has power. If board has power and LED is not blinking, replace board, page 38.
	380 V Only. In-rush Current Limiter contactor not closing when hose heat is turned on.	Check to see if contactor is snapping shut. If not check fuse item 120614. Replace if blown. In not blown move to transformer checks.
Low hose heat.	A and B temperature setpoints too low.	Increase A and B setpoints. Hose designed to maintain temperature, not increase temperature.
	Hose temperature setpoint too low.	Check. Increase if necessary to maintain heat.
	Flow too high.	Use smaller mix chamber. Decrease pressure.
	Low current; FTS not installed.	Install FTS, see operation manual.
	Hose heat zone not turned on long enough.	Allow hose to heat up, or preheat fluid.
	Loose hose electrical connections.	Check connections. Repair as necessary.

Repair

Pump Removal

 **WARNING**





Pump rod and connecting rod move during operation. Moving parts can cause serious injury such as pinching or amputation. Keep hands and fingers away from connecting rod during operation.

 See manual 309577 for pump repair instructions.

1. Shut off **A** , **B** , and  heat zones.

2. Flush pump, page 8.

3. If pumps are not parked, press  Trigger gun until pumps stop.

4. Turn main power OFF  . Disconnect power supply.

5. Shut off both feed pumps. Close both fluid inlet ball valves (B).

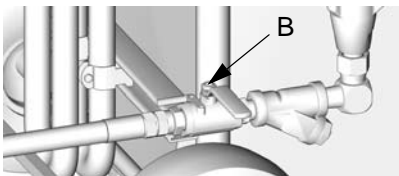

6. Turn both PRESSURE RELIEF/SPRAY valves (SA, SB) to PRESSURE RELIEF. Route fluid to waste containers or supply tanks. Ensure gauges drop to 0.

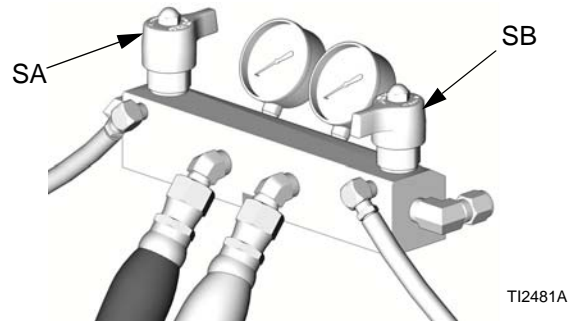

 Use dropcloth or rags to protect Reactor and surrounding area from spills.

 Steps 7-9 apply to pump A. See FIG. 4. To disconnect pump B, go to steps 10 and 11.

7. Disconnect fittings at fluid inlet (C) and outlet (D, out of view). Also disconnect steel outlet tube from heater inlet.
8. Disconnect tubes (T). Remove tube fittings (U) from wet-cup.
9. Loosen locknut (G) by hitting firmly with a non-sparking hammer. Unscrew pump far enough to separate and push up finger guard (P), to expose rod retaining pin. Push retaining wire clip up. Push pin out. Continue unscrewing pump.

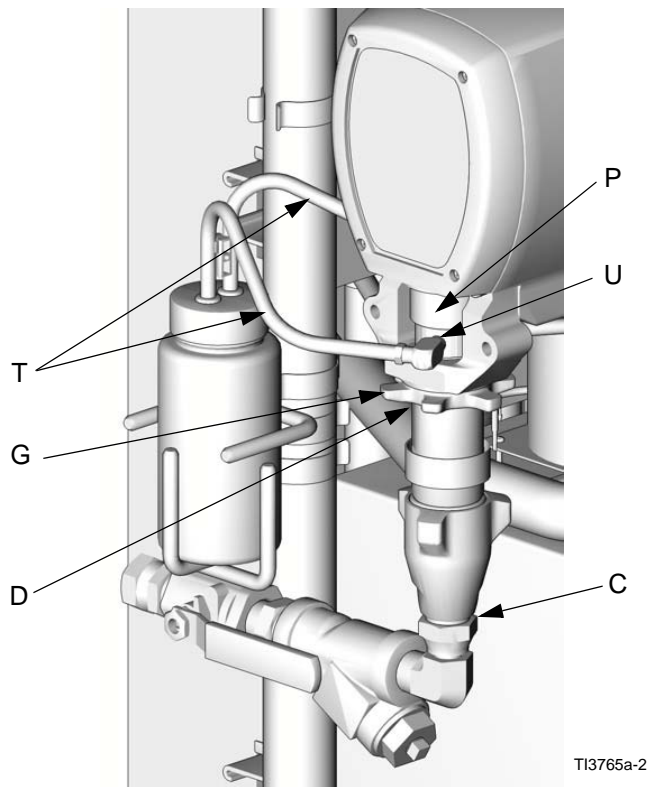

FIG. 4. Disconnect Pump A

 Steps 10 and 11 apply to pump B. See FIG. 5.

10. Disconnect fluid inlet (C) and outlet (D). Also disconnect steel outlet tube from heater inlet.
11. Push retaining wire clip (E) up. Push pin (F) out. Loosen locknut (G) by hitting firmly with a non-sparking hammer. Unscrew pump.

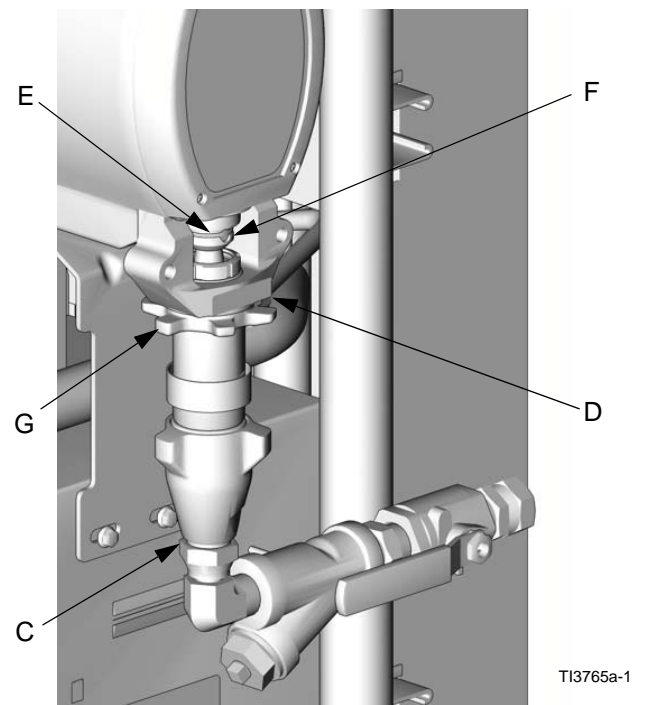



FIG. 5. Disconnect Pump B

Pump Installation

 Steps 1-5 apply to pump B. See FIG. 6. To reconnect pump A, go to step 6 on page 27.

1. Ensure locknut (G) is screwed on pump with flat side up. Screw pump into bearing housing (M) until pin holes align. Push pin (F) in. Pull retaining wire clip (E) down.

2. Continue screwing pump into housing until fluid outlet (D) is aligned with steel tube and top threads are +/- 1/16 in. (2 mm) of bearing face (N).

3. Tighten locknut (G) by hitting firmly with a non-sparking hammer.

4. Reconnect fluid inlet (C) and outlet (D).

5. Go to step 13, page 27.

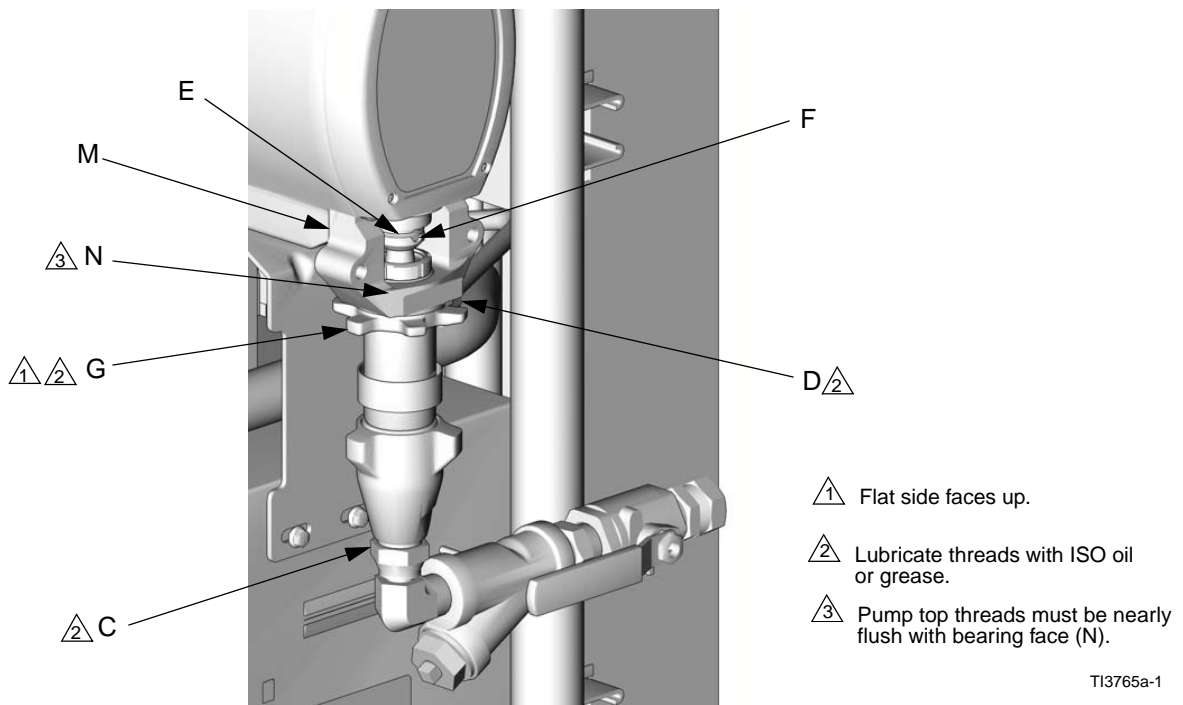

TI3765a-1

FIG. 6. Reconnect Pump B

 Steps 6-12 apply to pump A only. See FIG. 7.

6. Ensure star-shaped locknut (G) is screwed on pump with flat side up. Carefully twist and extend displacement rod 2 in. (51 mm) above wet-cup.
7. Start threading pump into bearing housing (M). Place finger guard (P) over rod when it is accessible through window of bearing housing. When pin holes align, insert pin. Pull retaining wire clip down.

 Finger guard is not used on Model E-30.

8. Seat finger guard (P) on wet-cup. Continue threading pump into bearing housing (M) until top threads are +/- 1/16 in. (2 mm) of bearing face (N). Ensure that barbed fittings at wet-cup flush ports are accessible.

9. Connect component A outlet tube loosely at pump and at heater. Line up tube, then tighten fittings securely.
10. Tighten star-shaped locknut (G) by hitting firmly with a non-sparking hammer.
11. Apply thin film of TSL to barbed fittings. Using two hands, support tubes (T) while pushing straight onto barbed fittings. **Do not let tubes kink or buckle.** Secure each tube with a wire tie between two barbs.
12. Reconnect fluid inlet (C).
13. Purge air and prime the system. See Reactor operation manual.

 Flat side faces up.

 Lubricate threads with ISO oil or grease.

 Pump top threads must be nearly flush with bearing face (N).

 Finger guard (P) not used on Model E-30.

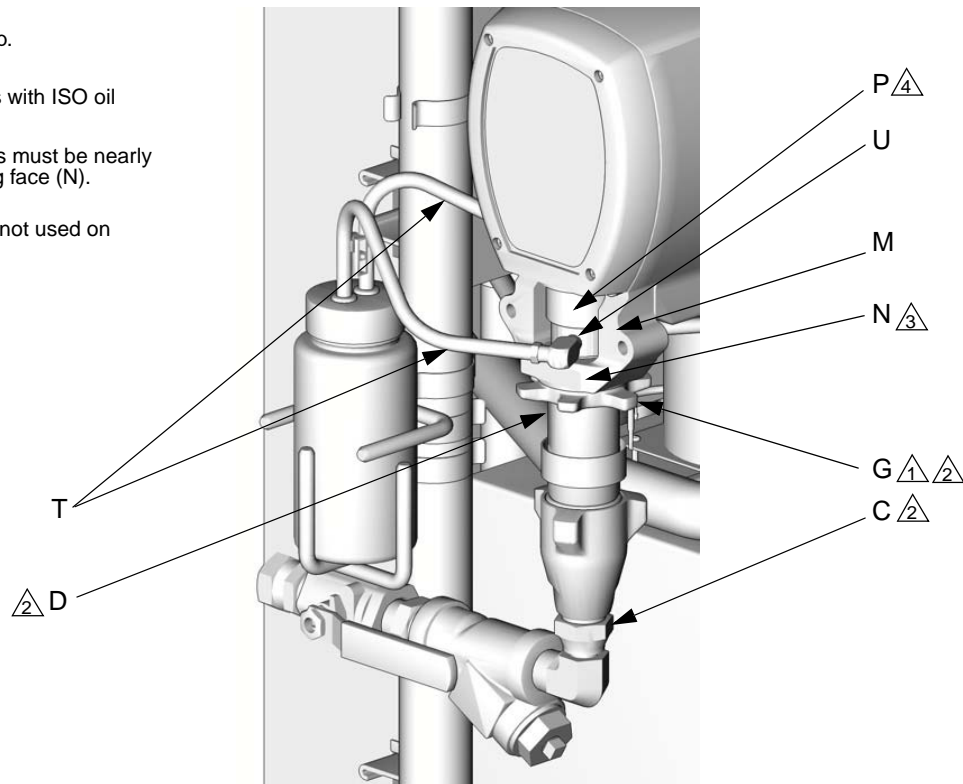



T13765a-2

FIG. 7. Reconnect Pump A

Drive Housing

Removal

1. Turn main power OFF . Disconnect power supply.
2. Relieve pressure, page 9.
3. Remove screws (38) and motor shield (9), page 53.
4. Remove screws (309) and front cover (317), FIG. 8.

 Examine bearing housing (303) and connecting rod (305). If these parts need replacing, first remove the pump (306), page 24.

5. Disconnect pump inlet and outlet lines. Remove screws (313), washers (315), and bearing housing (303).

 **CAUTION**
Do not drop gear cluster (304) when removing drive housing (302). Gear cluster may stay engaged in motor front end bell (R) or drive housing.

6. Remove screws (312, 319) and washers (314) and pull drive housing (302) off motor (301).

 The A side drive housing includes cycle counter switch (321). If replacing this housing, remove pins (P) and switch. Reinstall pins and switch on new drive housing. Switch wires connect to J10 pins 5 and 6 on motor control board, page 34.

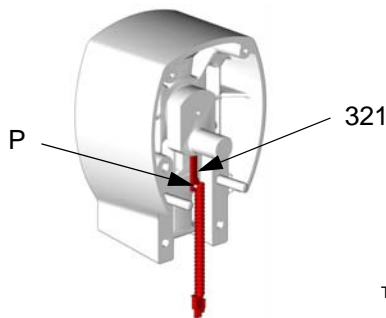

Installation

1. Apply grease liberally to washers (307, 308, 318), all gears, and inside drive housing (302).
2. Install one bronze washer (308) in drive housing, then install steel washers (307, 318) as shown.
3. Install second bronze washer (308) on gear cluster (304) and insert gear cluster in drive housing.

 Drive housing crankshaft (S) must be in line with crankshaft at other end of motor.

4. Push drive housing (302) onto motor (301). Install screws (312, 319) and washers (314).

 If bearing housing (303), connecting rod (305), or pump (306) were removed, reassemble rod in housing and install pump, page 24.

5. Install bearing housing (303), screws (313), and washers (315). Pumps must be in phase (both at same position in stroke).
6. Install front cover (317) and screws (309).
7. Install motor shield (9) and screws (38).

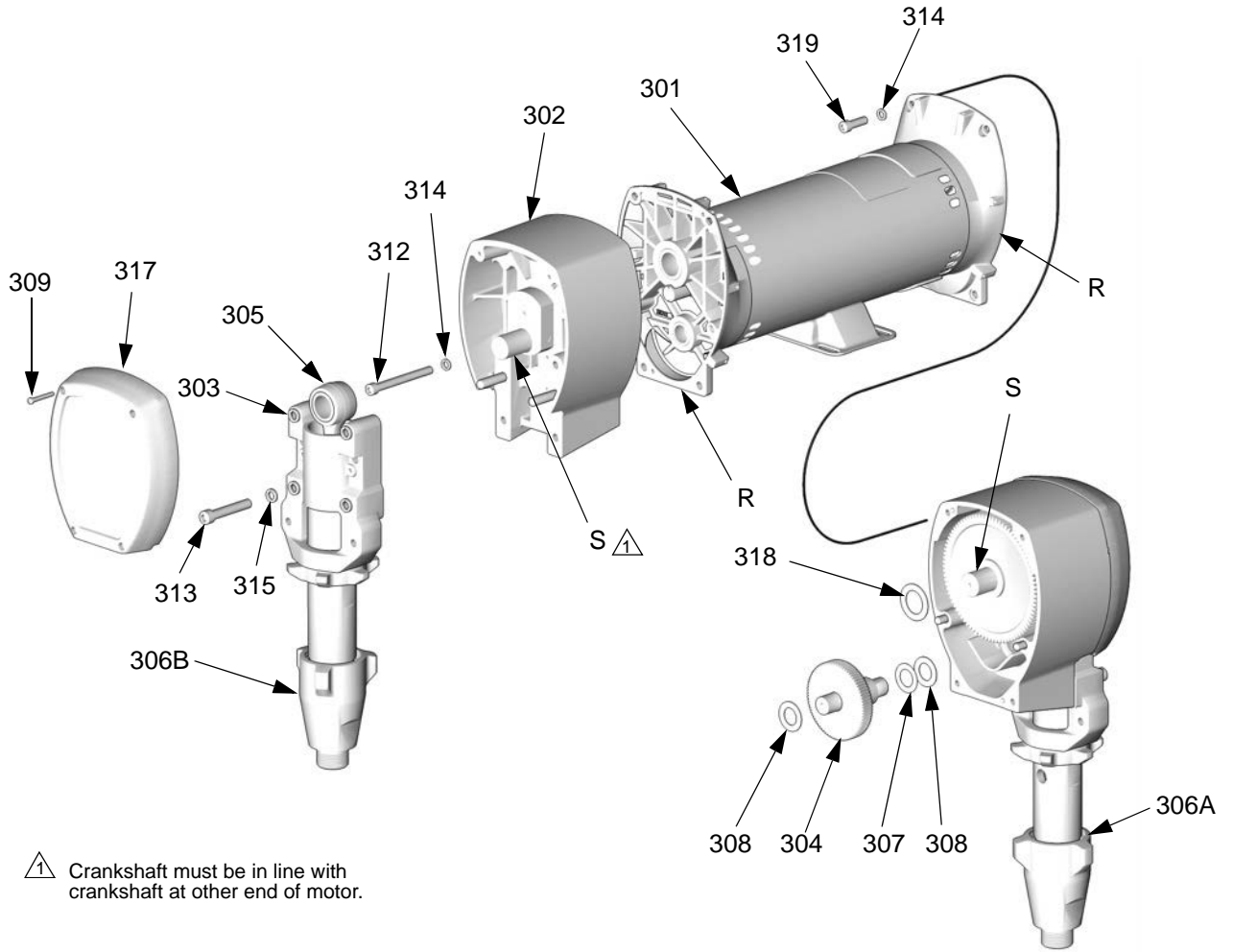

TI3152A

FIG. 8. Drive Housing

Motor Brushes

Brush Removal

 Replace brushes worn to less than 1/2 in. (13 mm). Brushes wear differently on each side of motor; check both sides. Brush Repair Kit 234037 is available.

1. Turn main power OFF . Disconnect power supply.

⚠ WARNING



Read warnings, page 6. Wait 5 min for stored voltage to discharge (E-30 and E-XP2 models only).

2. Relieve pressure, page 9.
3. Remove motor cover, screw, and washers. Remove inspection covers, screws, and gaskets from each end of motor.
4. Push in spring clip (C) to release hooks (H) from brush holder. Pull out clip and spring (S).

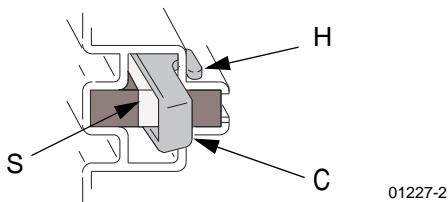

 One brush has a wire on top for brush wear signal. Note which side of motor it is on. Unplug at spade connector provided.

5. Loosen terminal screw (R). Pull away brush lead (L), being careful motor lead terminal (T) remains in place. Remove and discard brush (B).

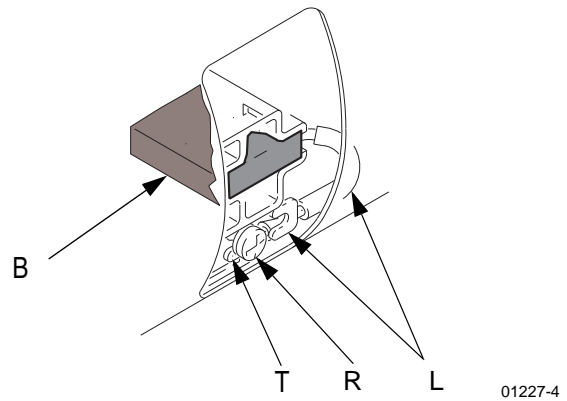

6. Inspect commutator for excessive pitting, burning, or gouging. Black color on commutator is normal. Have commutator resurfaced by qualified motor repair shop if brushes wear too quickly.
7. Repeat for other side.

Brush Installation

⚠ CAUTION

When installing brushes, follow steps carefully. Improper installation damages parts beyond use.

 Install brush with wires on same side of motor as before. Plug spade terminal into connector.

1. Install new brush (B) so lead (L) is in long slot (D) of holder.

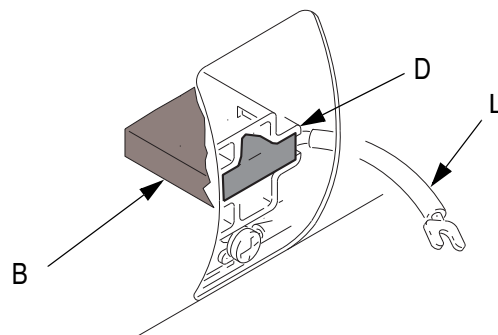

- Slide terminal (L) under terminal screw (R). Make sure motor lead terminal (T) is still connected at screw. Tighten screw.

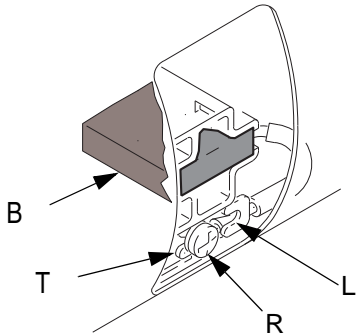

01227-4

- Install spring (S) so it will uncoil onto brush (B), as shown. Spring will be damaged if installed backwards.

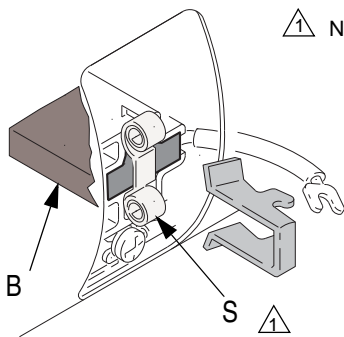

1 Note direction of spring coil.

01227-6

- Install spring clip (C) and push in until hooks (H) catch slots in housing. Incorrect installation may jam clip

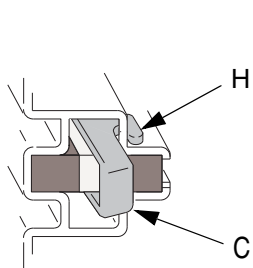

01227-2

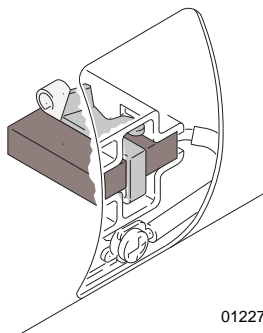

01227-6

WARNING



Do not touch brushes, leads, springs, or brush holders while equipment is plugged in, to reduce the risk of electric shock and serious injury.

CAUTION

Do not run pumps dry for more than 30 sec while checking brushes, to avoid damaging pumps.

- Reinstall brush inspection covers, gaskets, and screws. Reinstall motor cover, screws, washers, and drive housing/pump assemblies.
- Test brushes with both pump pins (F) disconnected, page 24.

Select J 1 (jog mode). Press motor  to start motor. Slowly increase jog setting to J 6. Inspect brush and commutator contact area for excessive arcing. Arcs should not "trail" or circle around commutator surface.

Run motor for 20-30 min at J 6 to seat brushes.

Circuit Breaker Module

1. Turn main power OFF . Disconnect power supply. Turn circuit breakers on to test.

WARNING



Read warnings, page 6. Wait 5 min for stored voltage to discharge (E-30 and E-XP2 models only).

2. Relieve pressure, page 9.

3. Using an ohmmeter, check for continuity across circuit breaker (top to bottom). If no continuity, trip breaker, reset, and retest. If still no continuity, replace breaker as follows:
 - a. Refer to electrical diagrams and to TABLE 1. Disconnect wires and remove bad breaker.
 - b. Install new breaker and reconnect wires.

Table 1: Circuit Breakers, see FIG. 9

Ref. No.	Size	Component
806	50 A	Hose/Transformer Secondary Side
817A	20 A	Transformer Primary
804A	25 or 40 A*	Heater A
804B	25 or 40 A*	Heater B
817B	20 A	Motor/Pumps

* Depending on model.

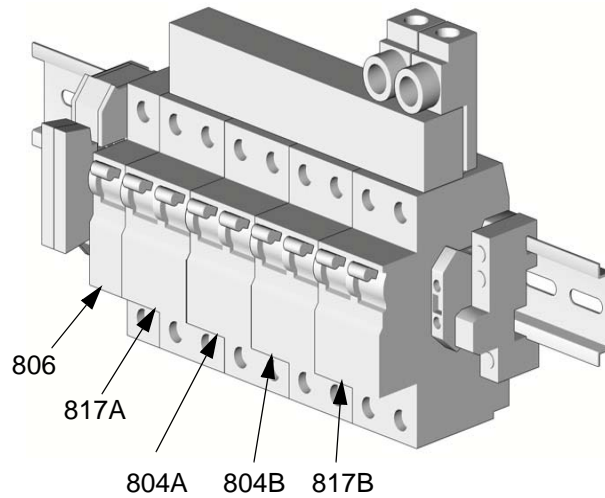

NOTE: To reference cables and connectors, see the electrical diagrams and the parts drawings on pages 68-70.

TI2514A

FIG. 9. Circuit Breaker Module

Electric Motor

Removal

1. Turn main power OFF . Disconnect power supply.

WARNING



Read warnings, page 6. Wait 5 min for stored voltage to discharge (E-30 and E-XP2 models only).

2. Relieve pressure, page 9.
3. Remove drive housing/pump assemblies, page 28.
4. Disconnect motor cables as follows:
 - a. Refer to electrical diagrams. Motor control board is on right side inside cabinet, see page 34.
 - b. Unplug motor power harness from connector J4 on board. See FIG. 10, page 35.
 - c. Unplug 3-pin connector J7 from board.
 - d. Thread cables through top of cabinet to free motor.

CAUTION

Motor is heavy. Two people may be required to lift.

5. Remove screws holding motor to cabinet. Lift motor off unit.

Installation

1. Place motor on unit. Thread motor cables into cabinet and into bundles as before. See electrical diagrams.
2. Fasten motor with screws.
3. Plug 3-pin connector J7 to board.

4. Plug motor power harness to connector J4 on board.
5. Install drive housing/pump assemblies, page 28.
6. Return to service.

Motor Control Board

 Motor control board has one red LED (D11 for 245980, D7 for 245981). Power must be on to check. See FIG. 10 for location. Function is:

- Startup: 1 blink for 60 Hz, 2 blinks for 50 Hz.
- Motor running: LED on.
- Motor not running: LED off.
- Diagnostic code (motor not running): LED blinks diagnostic code (for example, E21=21 blinks).

CAUTION

Before handling board, put on a static conductive wrist strap to protect against static discharge which can damage board. Follow instructions provided with wrist strap.

1. Turn main power OFF . Disconnect power supply.

WARNING



Read warnings, page 6. Wait 5 min for stored voltage to discharge (E-30 and E-XP2 models only).

2. Relieve pressure, page 9.
3. Refer to electrical diagrams. Motor control board is on right side inside cabinet.
4. Put on static conductive wrist strap.
5. Disconnect all cables and connectors from board.
6. Remove nuts (42) and take entire motor control assembly to workbench.
7. Remove screws and take board off heatsink.

8. Set DIP switch (SW2) on new board. See below for factory settings. See FIG. 10 for location on board.

WARNING



Read warnings, page 6. To prevent overpressurization, DIP switch 2 must be set to ON for Models E-20 and E-30.

- Switch 1: not used.
 - Switch 2: ON for Models E-20 and E-30, OFF for Models E-XP1 and E-XP2.
 - Switch 3: ON for pressure imbalance alarm, OFF for pressure imbalance warning.
 - Switch 4: not used.
9. Install new board in reverse order. Apply thermal heatsink compound to mating surfaces of board and heatsink.

 Order Part No. 110009 Thermal Compound.

Table 2: Motor Control Board Connectors

Model E-20 and E-XP1	Model E-30 and E-XP2	Pin	Description
J1	N, L	n/a	Main motor power
J3	J3	n/a	Transducer A
J4	J1	n/a	Motor output
J7	J6	1, 2	Motor thermal overload signal
		3	Brush wear signal
J8	J5	n/a	Transducer B
J10	J7	1-4	Not used
		5, 6	Cycle switch signal
		7-10	Jumper 15C866 (available in repair kit 246961)
J12	J12	n/a	Data reporting
J13	J13	n/a	To display board

245980 Motor Control, for E-20 and E-XP1

DIP Switch (SW2) Settings

Model E-20

ON



1 2 3 4 TI3178b-3

Model E-XP1

ON



1 2 3 4 TI3178b-4

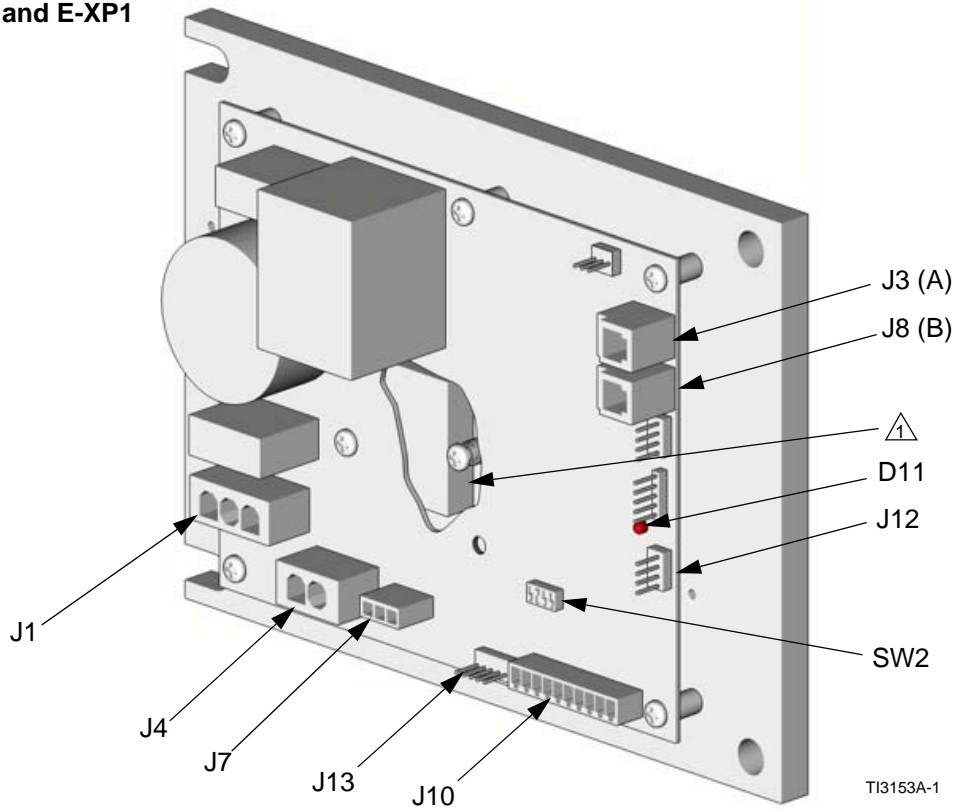

245981 Motor Control, for E-30 and E-XP2

DIP Switch (SW2) Settings

Model E-30

4 3 2 1



ON TI3178b-2

Model E-XP2

4 3 2 1



ON TI3178b-1

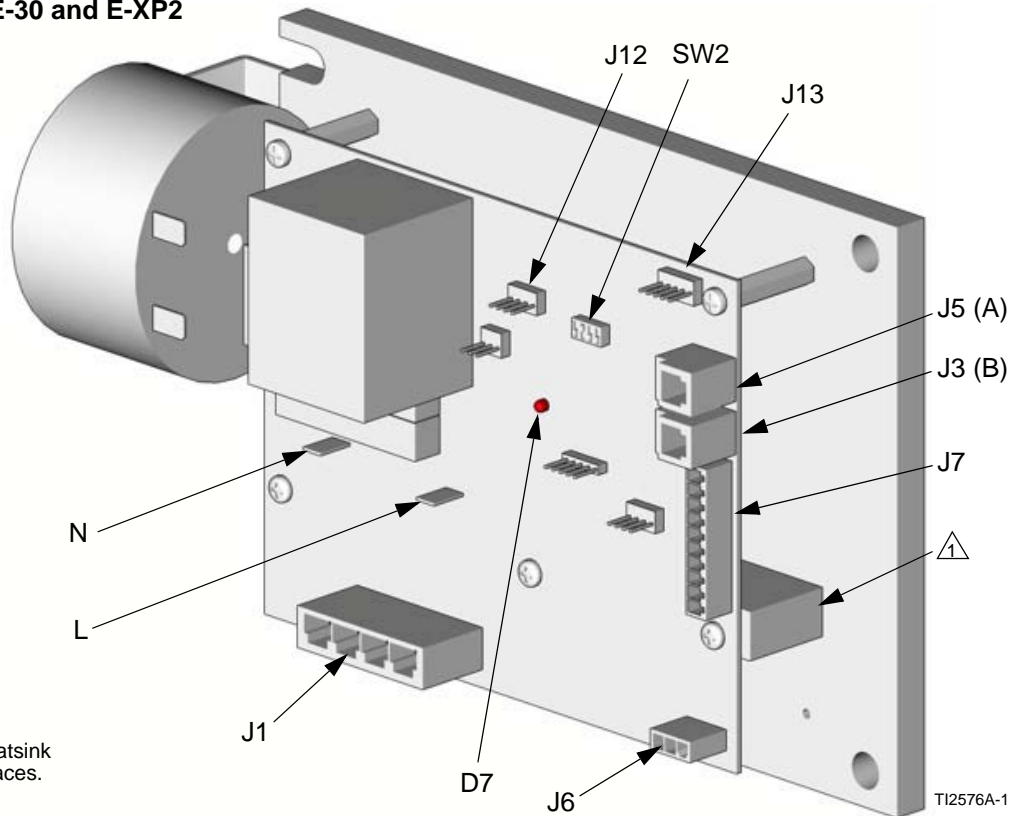

⚠ Apply 110009 thermal heatsink compound to mating surfaces.

FIG. 10. Motor Control Board

Transducers

1. Turn main power OFF . Disconnect power supply.

⚠ WARNING

Read warnings, page 6. Wait 5 min for stored voltage to discharge (E-30 and E-XP2 models only).

2. Relieve pressure, page 9.
3. Refer to electrical diagrams. Motor control board is on right side inside cabinet.

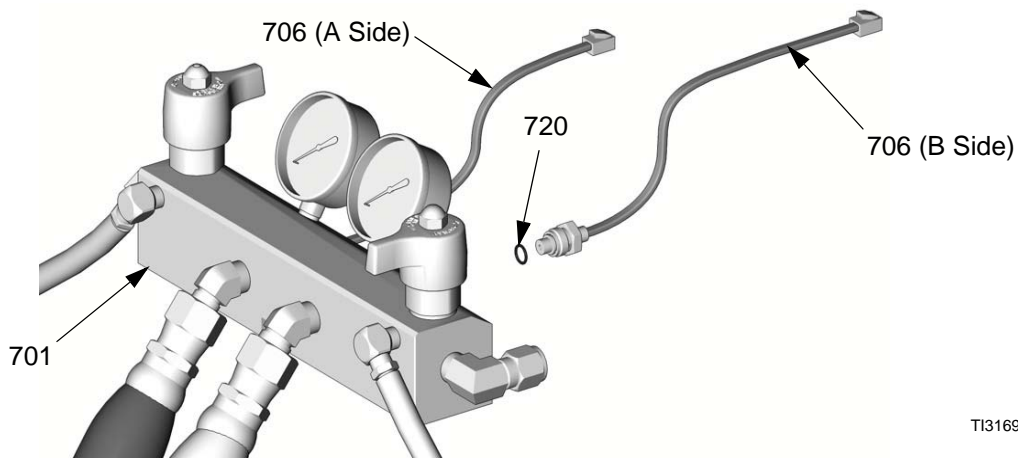
4. Disconnect transducer cables at board; see FIG. 10, page 35. Reverse A and B connections and check if diagnostic code follows, page 16.
5. If transducer fails test, thread cable through top of cabinet. Note path as cable must be replaced in same way.
6. Install o-ring (720) on new transducer (706), FIG. 11.
7. Install transducer in manifold. Mark end of cable with tape (red=transducer A, blue=transducer B).
8. Route cable into cabinet and thread into bundle as before.
9. Connect transducer cable at board; see FIG. 10, page 35.



TI3169a

FIG. 11. Transducers

Fan

1. Turn main power OFF . Disconnect power supply.

WARNING



Read warnings, page 6. Wait 5 min for stored voltage to discharge (E-30 and E-XP2 models only).

2. Relieve pressure, page 9.
3. Check fuses (F) at left of breaker module, FIG. 12. Replace if blown. If good, continue with step 4.
4. Refer to electrical diagrams. Disconnect fan wires from fuses (F). Thread wires through top of cabinet.
5. Remove fan.
6. Install fan in reverse order.

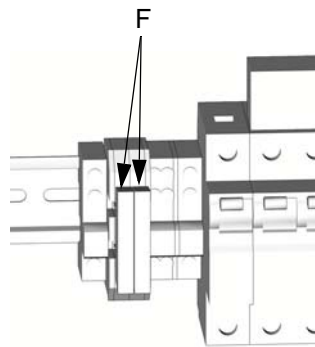

TI2514A-1

FIG. 12. Fan Fuses

Temperature Control Board





 Temperature control board has seven green LEDs. Power must be on to check. See FIG. 10 for location.

Table 3: Temperature Control Board LEDs

LED	Status	Function
D26	blinks	Board powered
D14	on	Zone A turned on
D13	cycles on and off	Zone A powered, LED cycles as temperature cycles
D18	on	Zone B turned on
D19	cycles on and off	Zone B powered, LED cycles as temperature cycles
D27	on	Hose zone turned on
D15	cycles on and off	Hose zone powered, LED cycles as temperature cycles

 **CAUTION**
 Before handling board, put on a static conductive wrist strap to protect against static discharge which can damage board. Follow instructions provided with wrist strap.

1. Turn main power OFF . Disconnect power supply.

 **WARNING**

 Read warnings, page 6. Wait 5 min for stored voltage to discharge (E-30 and E-XP2 models only).

2. Relieve pressure, page 9.
3. Refer to electrical diagrams. Temperature control board is on left side inside cabinet.
4. Put on static conductive wrist strap.
5. Disconnect all cables and connectors from board, FIG. 13.

6. Remove nuts and take entire temperature control assembly to workbench.
7. Remove screws and take board off heatsink.
8. Install new board in reverse order. Apply thermal heatsink compound to mating surfaces of board and heatsink.

 Order Part No. 110009 Thermal Compound.

Table 4: Temperature Control Board Connectors

Connector	Pin	Description	
J1	1, 2	Overtemperature switch A	
	3, 4	Overtemperature switch B	
	5, 6	Current sensor	
	7	Thermocouple A, red	
	8	Thermocouple A, yellow	
	9	Not used	
	10	Thermocouple B, red	
	11	Thermocouple B, yellow	
	12	FTS, silver	
	13	FTS, red	
	14	FTS, purple	
	J2	n/a	To A heaters
	J5	n/a	To display board
	J8	n/a	Data reporting
J9	n/a	To B heaters	
J13	n/a	To heated hose	

245979 Temperature Control Board

 Apply 110009 thermal heatsink compound to mating surfaces.

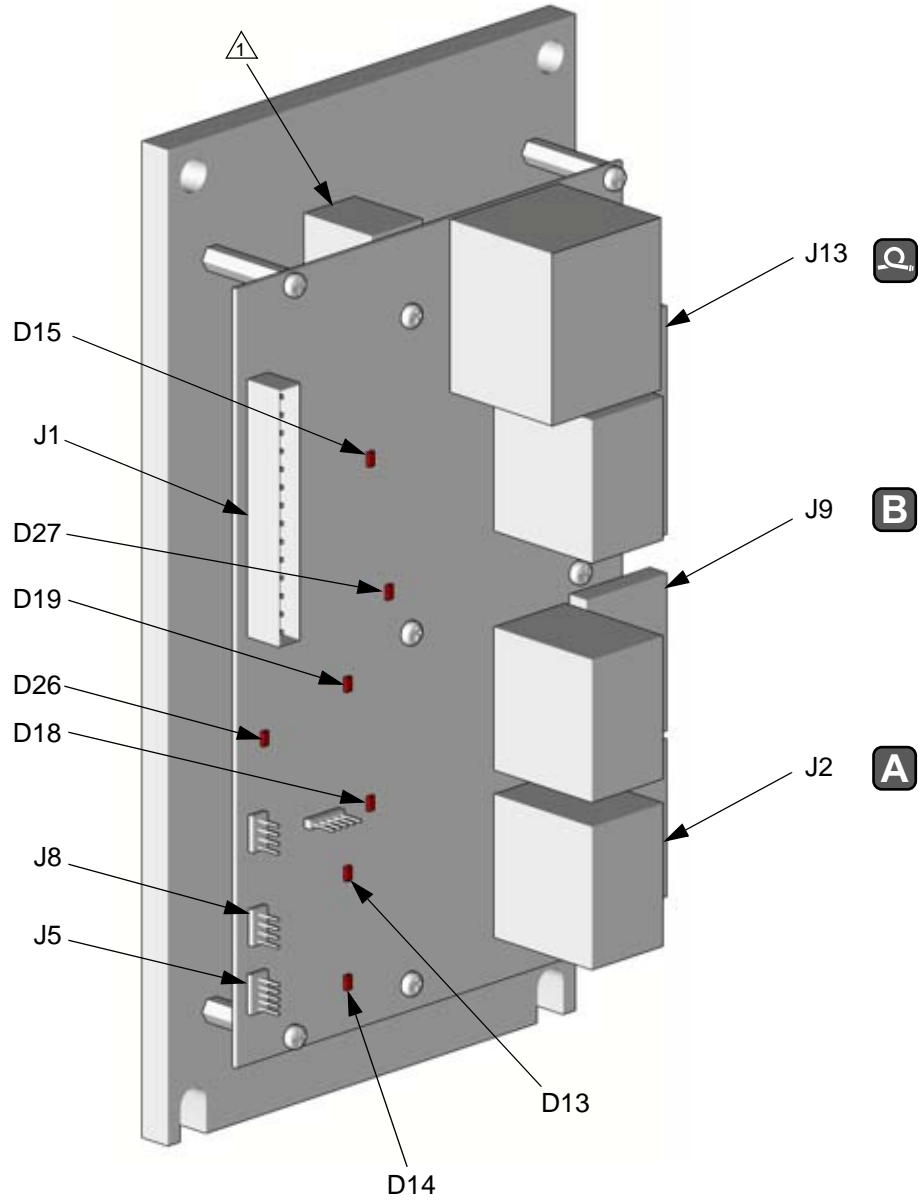

TI2572a

FIG. 13. Temperature Control Board

Heater

Heater Element

1. Turn main power OFF . Disconnect power supply.

2. Relieve pressure, page 9.

WARNING



Read warnings, page 7. Wait for heaters to cool before repairing.

3. Wait for heaters to cool.
4. See FIG. 14. Remove tape and wire connector (63, not shown), and disconnect heater element wires (W) from heater wire harness. Test with ohmmeter. Resistance must be 21-25 ohms for 2550W element, and 30-34 ohms for 1500W element.
5. If heater fails test, remove temperature sensor (211) to avoid damage.
6. Remove heater element (207) from tube (201). Be careful not to spill any fluid left in tube.
7. Install new heater element (207), holding mixer (202) so it does not interfere with Thermocouple (P).
8. Reinstall temperature sensor, page 41.
9. Reconnect wires and secure with connector (63) and electrical tape.

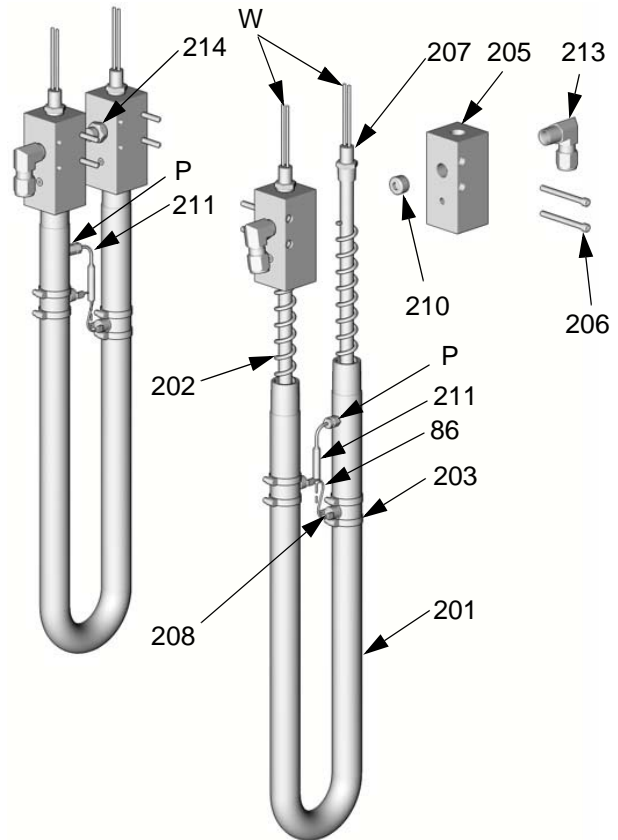

TI2512b

FIG. 14. Heater (Model 245962 Shown)

Thermocouple

1. Turn main power OFF . Disconnect power supply.

2. Relieve pressure, page 9.

WARNING



Read warnings, page 7. Wait for heaters to cool before repairing.

3. Wait for heaters to cool.
4. Disconnect thermocouple wires from J1 on temperature control board. See TABLE 4, page 38 and FIG. 13, page 39.
5. See FIG. 15. Test with ohmmeter. Between wires (S), resistance must be approximately 6 ohms. Between tip (T) and wires, resistance must be infinity (∞).
6. If thermocouple fails test, feed wires out of cabinet. Note path as wires must be replaced in the same way.
7. Loosen ferrule nut (N). Remove thermocouple (211) from heater tube (201), then remove sensor housing (H).
8. Replace thermocouple, FIG. 15.
 - a. Remove protective tape from thermocouple tip (T).
 - b. To ensure mixer (202) is out of the way, insert 1/4 in. drill bit into heater tube (201) to a minimum depth of 0.81 in. (20.6 mm). If minimum is not achieved, mixer must be moved before proceeding.
 - c. Apply PTFE tape and thread sealant to male threads and tighten thermocouple housing (H) into tube (201).
 - d. Push in thermocouple (211) so tip (T) contacts heater element (207), avoiding mixer (202).

- e. Tighten ferrule nut (N), holding thermocouple (T) against heater element.

9. Route wires into cabinet and thread into bundle as before. Reconnect wires to board.
10. Turn on heaters A and B simultaneously to test. Temperatures should rise at same rate (30°F, +/- 4°). If one heater is low, loosen ferrule nut (N) and tighten sensor housing (H) to ensure thermocouple tip (T) contacts element (207).

 Apply PTFE tape and thread sealant.

 Apply 110009 thermal heatsink compound.

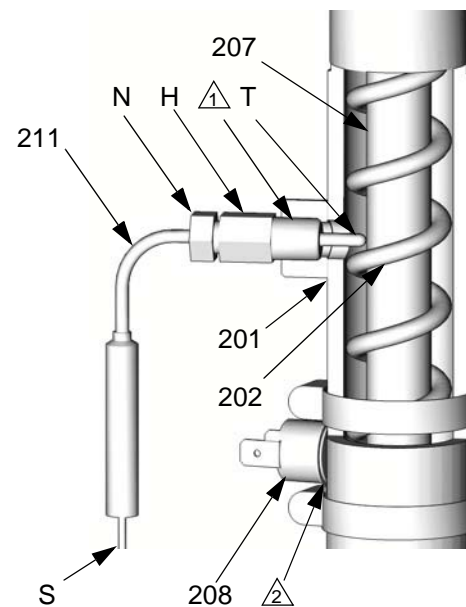

TI3249a

FIG. 15. Thermocouple

Overtemperature Switch

1. Turn main power OFF . Disconnect power supply.

2. Relieve pressure, page 9.

 **WARNING**



Read warnings, page 7. Wait for heaters to cool before repairing.

3. Wait for heaters to cool.
4. Disconnect one leadwire from overtemperature switch (208), FIG. 15. Test across switch with ohmmeter. Resistance must be approximately 0 ohms.
5. If switch fails test, cut off clamps with wire clippers. Remove switch. Install new switch in same location on tube (201) and secure with hose clamps (203). Reconnect wires.

 If wires need replacement, disconnect from temperature control board. See TABLE 4, page 38 and FIG. 13, page 39.

Heated Hose

 Refer to the heated hose manual 309572 for hose replacement parts.

Check Hose Connectors

1. Turn main power OFF . Disconnect power supply.

2. Relieve pressure, page 9.

 Whip hose must be connected.

3. Disconnect hose electrical connector (D) at Reactor, FIG. 16.

4. Using an ohmmeter, check between the two terminals of hose connector (D). There should be continuity.

5. If hose fails test, retest at each length of hose, including whip hose, until failure is isolated.

Check FTS Cables

1. Turn main power OFF . Disconnect power supply.

2. Relieve pressure, page 9.

3. Disconnect FTS cable (F) at Reactor, FIG. 16.

4. Test with ohmmeter between pins of cable connector.

Pins	Result
1 to 2	approximately 35 ohms per 50 ft (15.2 m) of hose, plus approximately 10 ohms for FTS
1 to 3	infinity (∞)

5. If cable fails test, retest at FTS, page 44.

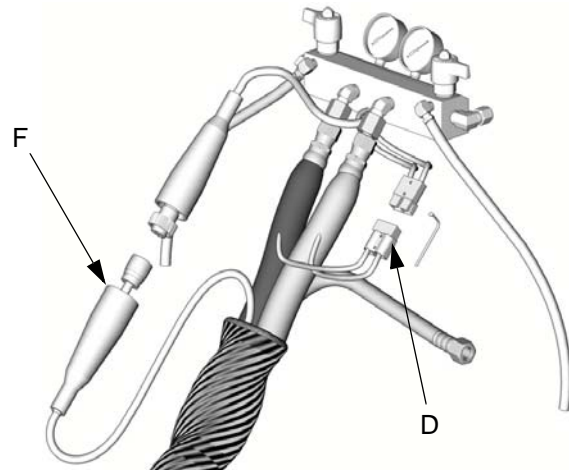

T12726a

FIG. 16. Heated Hose

 When inserting contact into connector (D) ensure that notch of contact snaps over edge of spring clip as shown in the cutaway drawing. See FIG. 17.

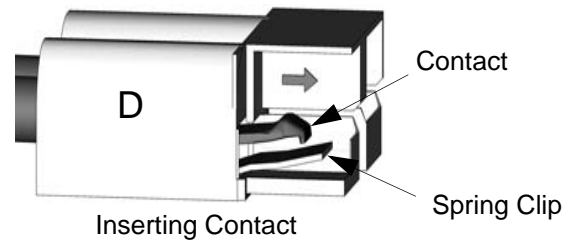

T18367

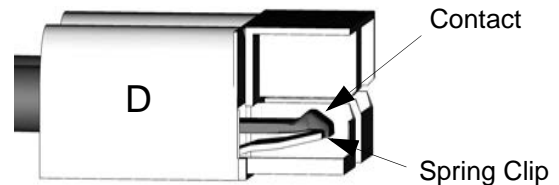

Contact fully inserted and correctly snapped onto spring clip.

T18368A

FIG. 17 Connector

Fluid Temperature Sensor (FTS)

Test/Removal

1. Turn main power OFF . Disconnect power supply.
2. Relieve pressure, page 9.
3. Remove tape and protective covering from FTS (X), FIG. 18. Disconnect hose cable (F). Test with ohmmeter between pins of cable connector.

Pins	Result
1 to 2	approximately 10 ohms
1 to 3	infinity (∞)
3 to FTS groundscrew	0 ohms
1 to FTS component A fitting (ISO)	infinity (∞)

4. If FTS fails test, replace FTS.
5. Disconnect air hoses (C, L), and electrical connectors (D).
6. Disconnect FTS from whip hose (W) and fluid hoses (A, B).
7. Remove ground wire (K) from ground screw on underside of FTS.
8. Remove FTS probe (H) from component A (ISO) side of hose.

Installation



CAUTION

To prevent damage to probe, do not kink or excessively bend whip hose. Do not coil hose tighter than the minimum bend radius of 3 ft (0.9 m). Do not subject hose to excessive weight, impact, or other abuse.

1. Carefully extend FTS probe (H). Do not bend or kink probe. Insert in component A (ISO) side of main hose.

2. Connect whip hose ground wire (K) to ground screw on underside of FTS.
3. Install FTS in reverse order of removal. Leave slack (G) in cables as stress relief, to prevent cable failure.
4. Secure hose and cable connections with tape and install protective covering.

SCR Circuit check – ON position:

1. Ensure that all harnesses, cables, and connectors are properly connected. Connect hose.
2. Connect power supply. Turn main power ON .
3. Set hose heat target temperature above ambient hose temperature
4. Turn on heat zone by pressing .

WARNING



Read warnings, page 6. Step 5 measures line voltage and should be done by a qualified electrician. If work is not performed properly it may cause electric shock or other serious injury.

5. Carefully measure the voltage at the white Anderson connector for the hose.

You should read:

- 50' = 20 VAC
- 100' = 34 VAC
- 150' = 48 VAC
- 200' = 62 VAC
- 250' = 76 VAC
- 300' = 90 VAC

SCR Circuit check - OFF position

1. Ensure that all harnesses, cables, and connectors are properly connected. Connect hose.
2. Connect power supply. Turn main power ON .
3. Set hose heat target temperature below ambient hose temperature.

4. Turn on heat zone by pressing .

 **WARNING**



Read warnings, page 6. Step 5 measures line voltage and should be done by a qualified electrician. If work is not performed properly it may cause electric shock or other serious injury.

5. Carefully measure the voltage at the white Anderson connector for the hose. You should not get a voltage reading. If you do get a voltage reading, the SCR on the circuit board has been damaged and the board needs to be replaced.

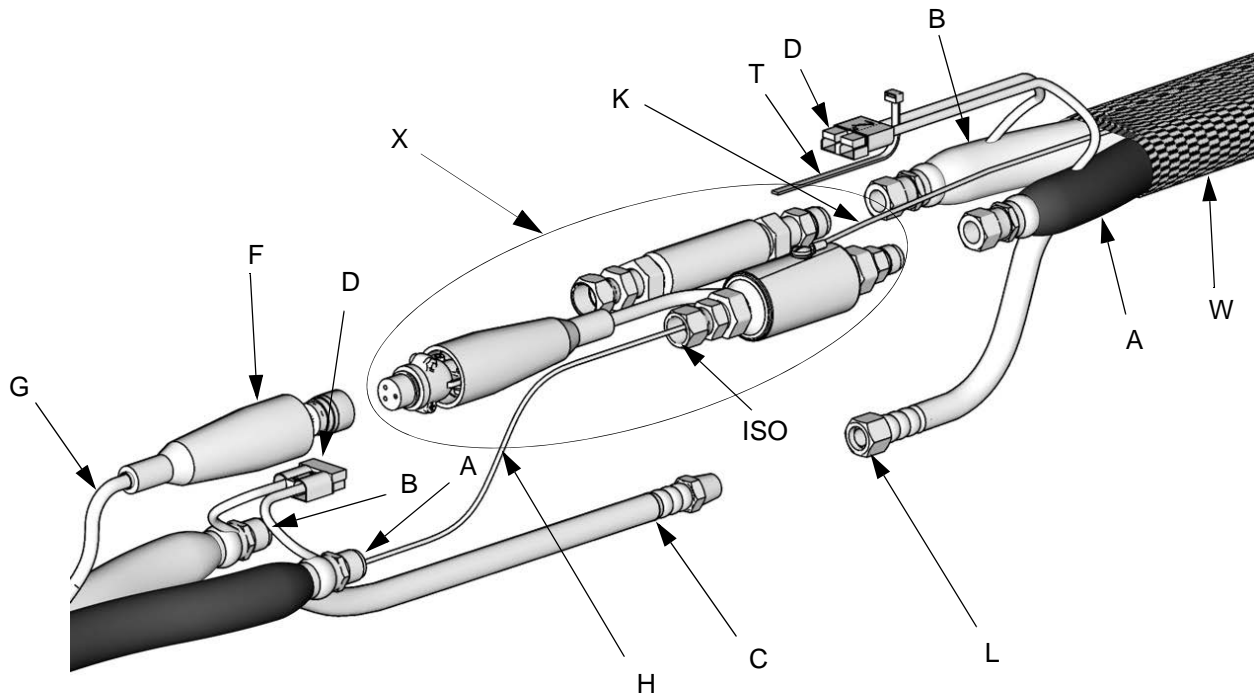

TI9582a1

FIG. 18. Fluid Temperature Sensor and Heated Hoses

Wire Harness Check

Test Hose Continuity

1. Turn main power OFF . Disconnect power supply. Leave hose plugged in.
2. See FIG. 19. Disconnect 6-pin transformer connector (P) from J13 at temperature control board. Remove red wire from transformer hose length tap you are using (R).
3. Using an ohmmeter, check between pin 6 (P6) of connector (not board) and red wire (R). There should be continuity.
4. If test fails, trace wires until failure is located.

Test Temperature Control Board to Transformer Wire Harness Continuity

1. Turn main power OFF . Disconnect power supply. Leave hose plugged in.
2. See FIG. 19. Disconnect 6-pin transformer connector (P) from J13 at temperature control board.
3. Check for continuity between:
 - a. Connector pin 1 (P1) and T1 on 20A hose circuit breaker (817A).
 - b. Connector pin 3 (P3) and T2 on 20A hose circuit breaker (817A).
 - c. Connector pin 5 (P5) and T3 on 50A hose circuit breaker (806).

(380 V Only) In-rush Current Limiter Test

1. Ensure all harnesses, cables and connectors are properly connected. Connect hose.
2. Connect main power supply. Turn main power on.
3. Turn on hose heat by pressing hose heat button



4. Contactor in front of transformer should snap shut.
5. If contactor does not close, turn main power off and check fuse item 120614. If blown replace.
6. If contactor does not close when hose heat is turned on with new fuse move to transformer checks.
7. If fuse continually blows, replace In-rush limiter kit 288359.

Test Current Sensor Continuity

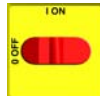
1. Turn main power OFF . Disconnect power supply.
2. Disconnect 14-pin connector from J1 on temperature control board, page 38.
3. Using an ohmmeter, test for continuity across pins 5 and 6 of connector (not board). Reading should be 20-25 ohms. If not, replace current sensor (32). See FIG. 19.

Detail B: Circuit Breaker Module and Hose Heat Wire Harness

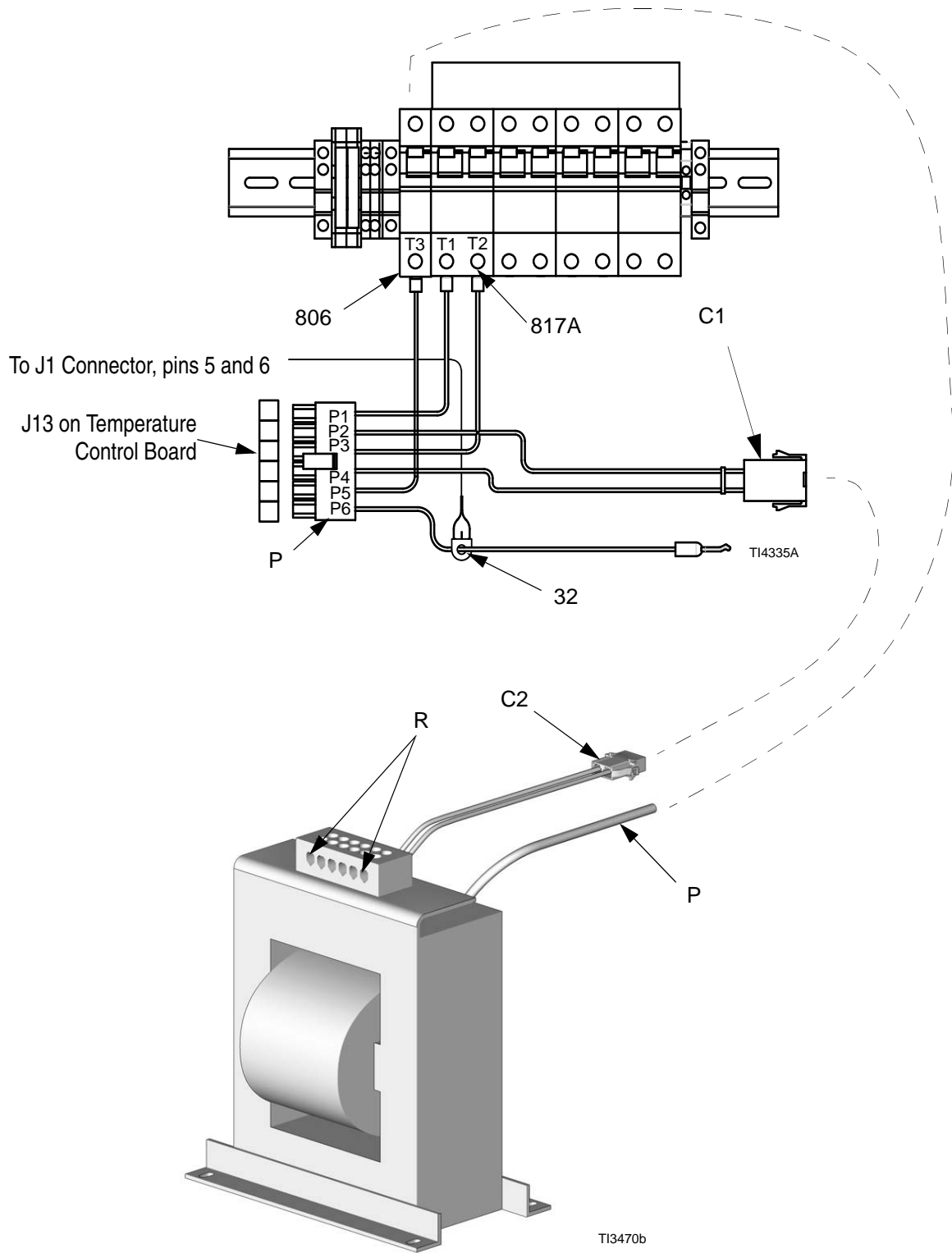

Part No. 15B352 Transformer (Models E-30 and E-XP2) shown



FIG. 19. Transformer Continuity Tests

Transformer Primary Check

1. Ensure that all harnesses, cables, and connectors are properly connected. Connect hose.
2. Disconnect wire harness (C1) from wire harness (C2).
3. Connect power supply. Turn main power ON



4. Set hose heat target temperature below current hose temperature.

5. Turn on  heat zone by pressing .

 **WARNING**



Read warnings, page 6. Step 6 measures line voltage and should be done by a qualified electrician. If work is not performed properly it may cause electric shock or other serious injury.



6. See FIG. 19, Detail B. Measure voltage across pins P2 and P4 of six-pin connector on temperature control board. Measurement should be line voltage. If not, replace temperature control board, page 38.

Transformer Secondary Check

1. Ensure that all harnesses, cables, and connectors are properly connected. Connect hose.
2. Connect power supply. Turn main power ON



3. Set hose heat target temperature below current hose temperature.

4. Turn on  heat zone by pressing .

 **WARNING**



Read warnings, page 6. Step 5 measures line voltage and should be done by a qualified electrician. If work is not performed properly it may cause electric shock or other serious injury.

5. See FIG. 20, Detail B. Measure voltage across transformer hose tap (R) currently in use and top terminal (T4) on 50A hose circuit breaker (806). See TABLE 5 for readings. If the reading is correct, the transformer is good. If the reading is wrong, conduct transformer primary check, page 48. If after doing primary check you have line voltage but not secondary voltage, then replace transformer, page 49.

Table 5: Transformer Voltage Readings

Transformer Tap	Reading (VAC)
50'	20
100'	34
150'	48
200'	62
250'	76
300'	90

Replace Transformer

 Use this procedure to replace transformer.

1. Turn main power OFF . Disconnect power supply.

WARNING



Read warnings, page 6. Wait 5 min for stored voltage to discharge (E-30 and E-XP2 models only).

2. Open Reactor cabinet.
3. Remove bolts holding transformer to cabinet floor. Slide transformer forward.
4. Unplug 2-pin wire harness connector (C) from wire harness coming from temperature control board.
5. Disconnect the transformer's secondary common wire (P) from T4 at 50 amp circuit breaker (806).
6. Remove transformer from cabinet.
7. Install new transformer in reverse order.

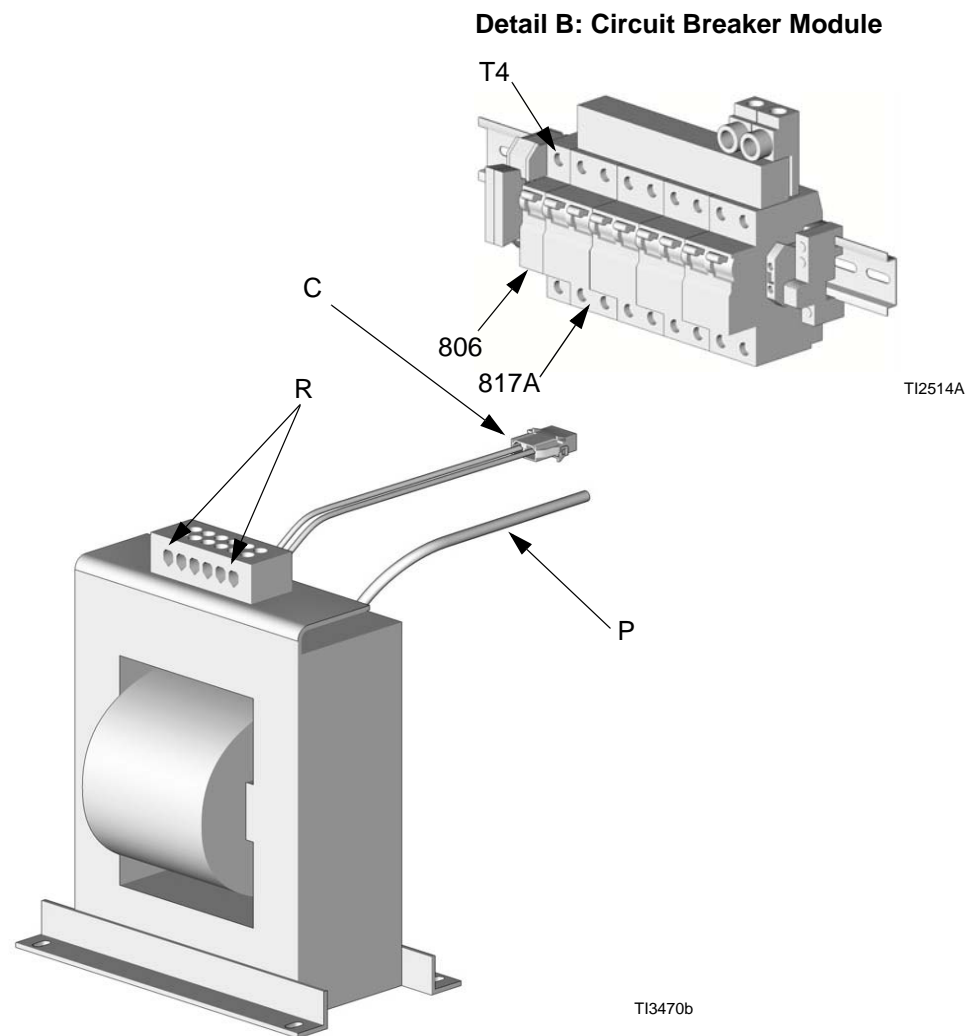

Part No. 15B352 Transformer (Models E-30 and E-XP2) shown

FIG. 20. Transformer

Display Module

Temperature and Pressure Displays

<p>⚠ CAUTION</p> <p>Before handling board, put on a static conductive wrist strap to protect against static discharge which can damage board. Follow instructions provided with wrist strap.</p>

1. Turn main power OFF  . Disconnect power supply.

<p>⚠ WARNING</p> <p></p> <p>Read warnings, page 6. Wait 5 min for stored voltage to discharge (E-30 and E-XP2 models only).</p>

2. Relieve pressure, page 9.
3. Refer to electrical diagrams.
4. Put on static conductive wrist strap.
5. Disconnect main display cable (20) at lower left corner of display module, FIG. 21.
6. Remove screws (409, 410) and cover (404).

 If replacing both displays, label temperature display cables TEMP and pressure display cables PUMP before disconnecting.

7. Disconnect cable connectors J1 and J13 from back of temperature display (401) or pressure display (402).
8. Disconnect ribbon cable(s) (R) from back of display.
9. Remove nuts (408) and plate (405).
10. Disassemble display, see detail in FIG. 21.
11. Replace board (401a or 402a) or membrane switch (401b or 402b) as necessary.
12. Reassemble in reverse order, see FIG. 21. Apply medium strength thread sealant where shown. Be sure display cable ground wire (G) is secured

between cable bushing and cover (404) with screws (412). Also check ground connection at rear of Reactor, see below.

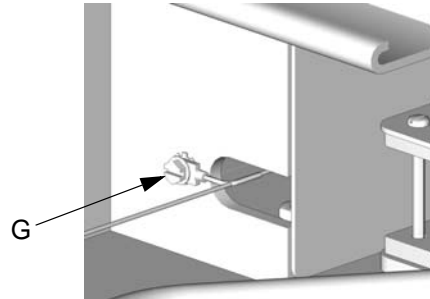

TI3743a

⚠ Apply medium strength thread sealant.

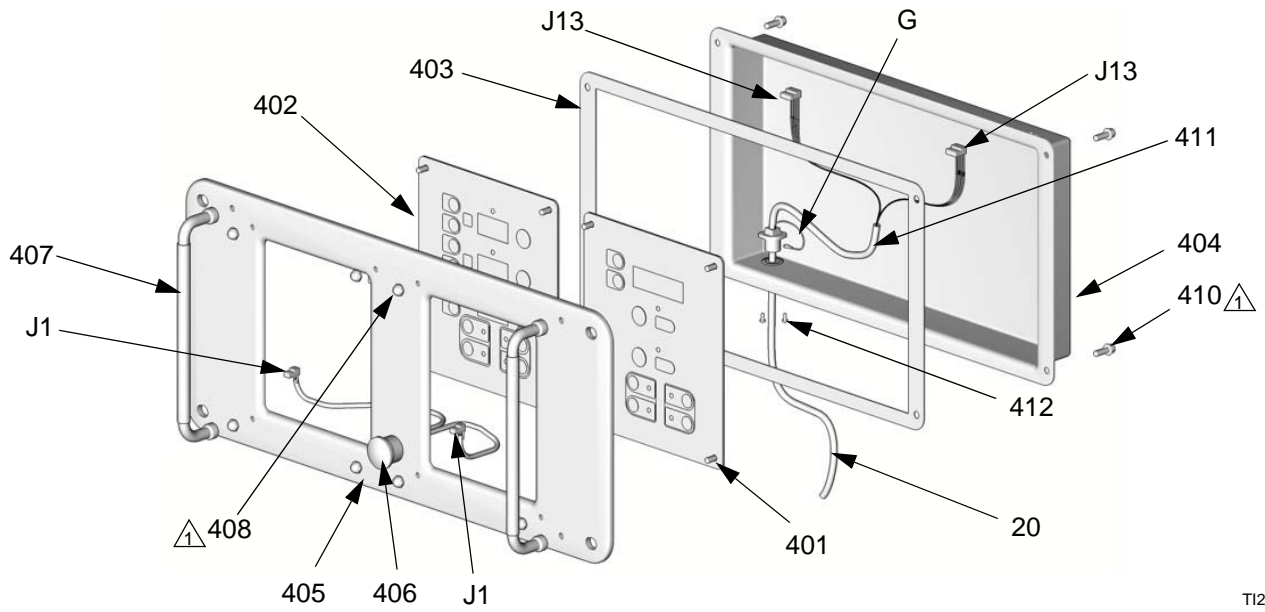

TI2574A

Detail of Membrane Switches and Display Boards

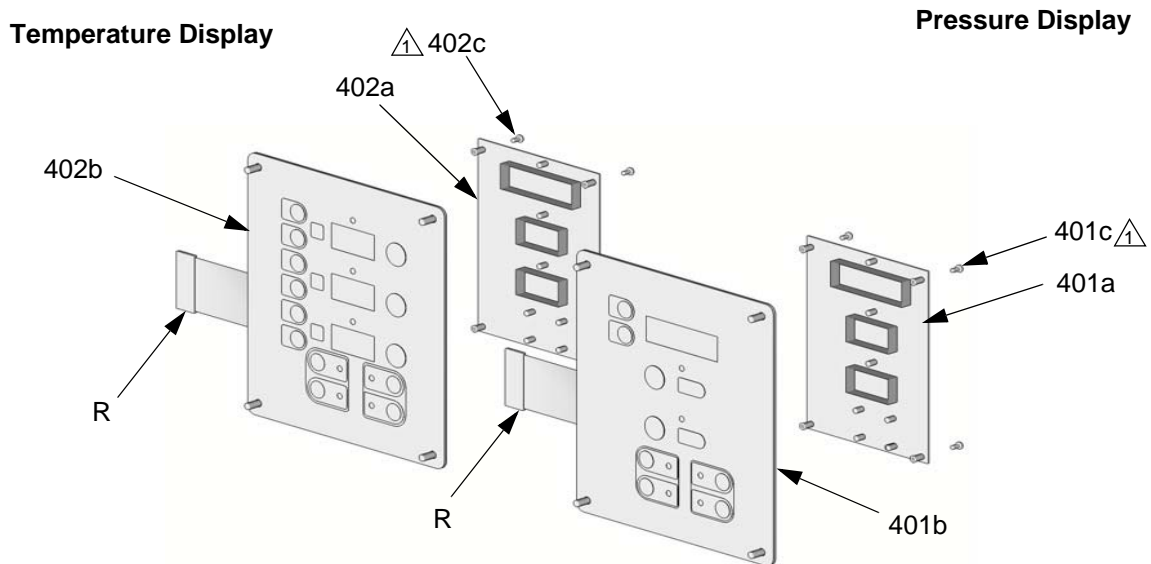

TI3172a

FIG. 21. Display Module

Red Stop Button

CAUTION

Before handling board, put on a static conductive wrist strap to protect against static discharge which can damage board. Follow instructions provided with wrist strap.

1. Turn main power OFF  . Disconnect power supply.

WARNING



Read warnings, page 6. Wait 5 min for stored voltage to discharge (E-30 and E-XP2 models only).

2. Relieve pressure, page 9.
3. Refer to electrical diagrams.
4. Put on static conductive wrist strap.
5. Remove screws (409, 410) and cover (404), FIG. 21.
6. Disconnect button cable connectors J1 from back of temperature display (401) and pressure display (402).
7. Remove red stop button (406).
8. Reassemble in reverse order. Be sure display cable ground wire (G) is secured between cable bushing and cover (404) with screws (412).

Parts

Reactor Assembly (Model E-XP1 Shown)

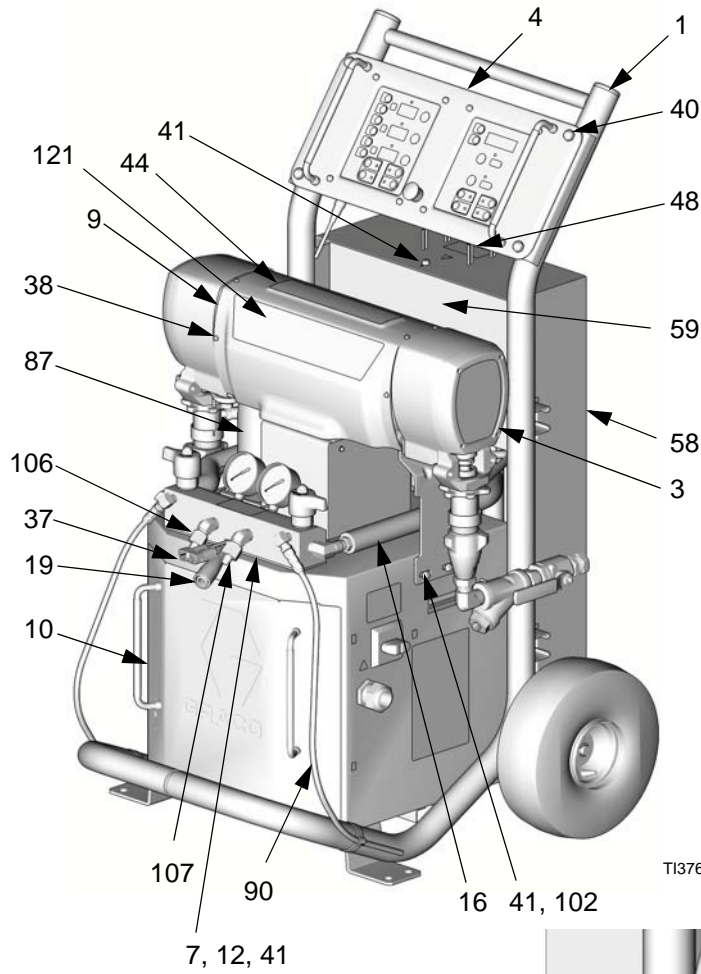

T13764a-1

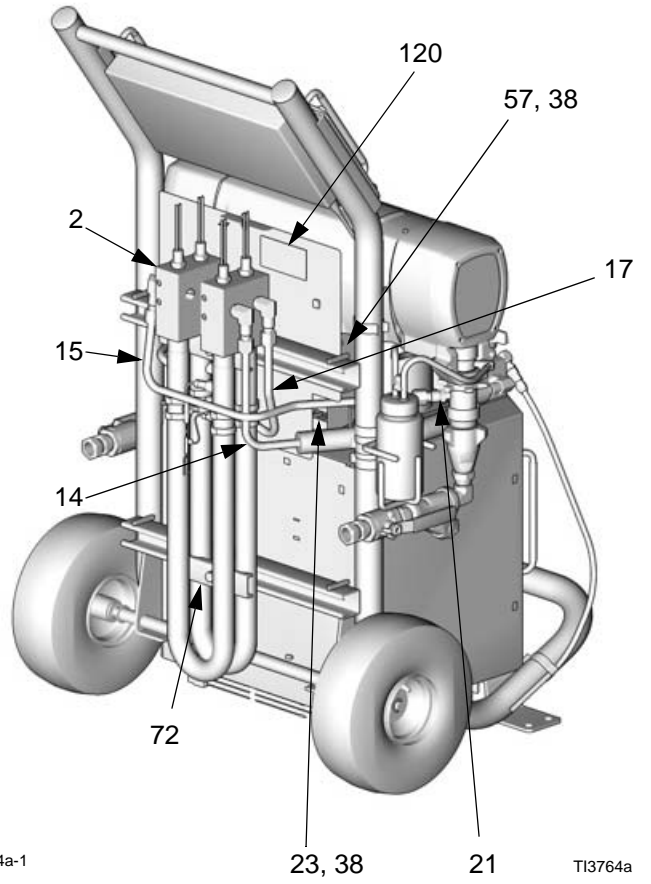

T13764a

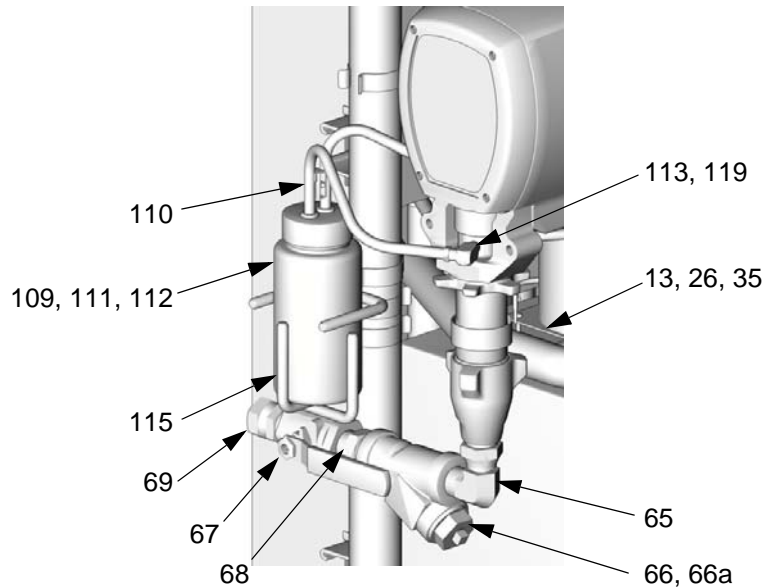

T13765a-2

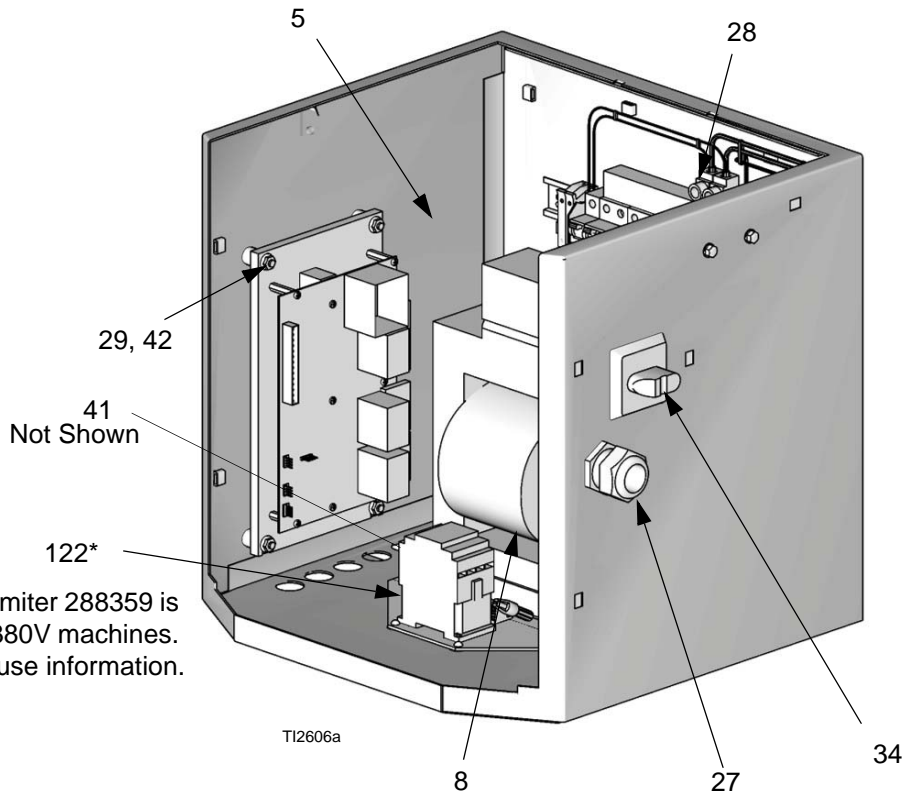

* In-rush current limiter 288359 is only included on 380V machines. See page 58 for fuse information.

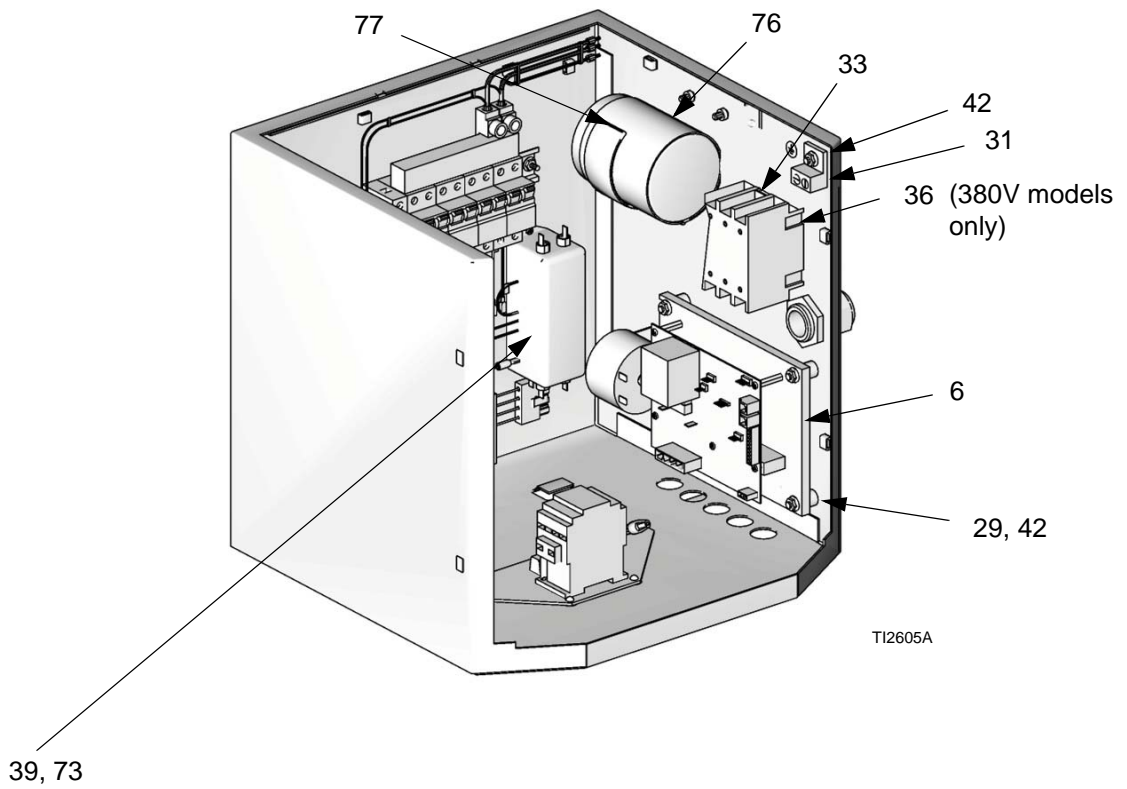

Reactor Assembly

Common Parts

See pages 56 through 58 for parts that vary by model.

Ref. No.	Part No.	Description	Qty	Ref. No.	Part No.	Description	Qty
1	245954	FRAME; page 59	1	58	15B797	COVER, heater, back	1
2		HEATER; page 56 and 58	*	59	15B798	COVER, heater, front	1
3		MODULE, proportioner; page 56 and 58	*	60▲	15B679	LABEL, warning	1
4	245974	DISPLAY; page 63	1	61	113505	NUT, hex, keps; 10-24	6
5	245979	CONTROL, temperature; page 64	1	62	112776	WASHER, plain; no. 10	2
6		CONTROL, motor; page 56 and 58	*	63	117722	CONNECTOR, wire; not shown, see electrical diagrams	4
7	246154	MANIFOLD, fluid; page 67	1	65		ELBOW, swivel; 3/4 npt(m) x 1" npt(f); 57 and 58	*
8		TRANSFORMER; page 56 and 58	*	66	101078	Y-STRAINER; includes 66a	2
9		SHIELD; page 56 and 58	*	66a	26A349	KIT, filter, replacement (2 pack)	1
10	246976	DOOR, cabinet	1		26A350	KIT, filter, replacement (10 pack)	1
11	261669	SENSOR, fluid temperature	1	67	109077	VALVE, ball; 3/4 npt (fbc)	2
12	15B456	GASKET, manifold	1	68	C20487	NIPPLE; 3/4 npt	2
13	115834	FAN	1	69	157785	UNION, swivel; 3/4 npt(m) x 3/4 npsm(f)	2
14		TUBE, heater component A; page 56 and 58	*	71		SCREW, machine; 6-32	2
15		TUBE, pump, component A; page 56 and 58	*	72		BRACKET, heater; page 57 and 58	*
16		TUBE, heater component B; page 56 and 58	*	73		WASHER, lock; page 57 and 58	*
17		TUBE, pump, component B; page 56 and 58	*	76		CAPACITOR; page 57 and 58	*
18	15B374	CABLE, overtemperature; not shown, see electrical diagrams	1	77		BRACKET; page 57 and 58	*
19	15B380	CABLE, hose control; not shown, see electrical diagrams	1	79	112512	FERRULE	2
20	15B383	CABLE, display	1	86		CABLE, overtemperature, jumper; page 57 and 58	*
21		CONNECTOR, tube; page 56 and 58	*	87	15B807	SHIELD, fan	1
22	116773	CONNECTOR, plug	1	88	186494	CLIP, spring	6
23	C38163	WASHER, lock, external tooth	1	89	205447	COUPLING, hose	2
24	15B361	BOOT, wire feed through	1	90	054826	TUBE, low pressure; 1/4 in. (6 mm) ID; 3/8 in. (16 mm) OD; 4 ft (1.2 m); PTFE	1
25	15B510	PLATE, cover, wire	1	92		CABLE, harness, power; 57 and 58	*
26	15B360	GASKET, fan	1	95		BOLT, hex hd; 3/8-16 (E-XP2 models) (all other models)	4
27	117682	STRAIN RELIEF	1	96		LOCKWASHER; 3/8; page 57 and 58	*
28		MODULE, breaker; page 56 and 58	*	97		NUT, channel; page 57 and 58	*
29	116149	SPACER	8	102		STRAP, motor; page 57 and 58	*
31	117666	TERMINAL, ground	1	106	117502	REDUCER; #5 x #8 JIC	1
32	15B388	SENSOR, current, hose; not shown, see electrical diagrams	1	107	117677	REDUCER; #6 x #10 JIC	1
33	117564	SWITCH, disconnect	1	109	246928	RESERVOIR; includes 110-119; see 309911	1
34	117545	SWITCH, main power	1	110	054826	TUBE; PTFE; 1/4 in. (6 mm) ID; 2 ft (0.6 m)	2
35	117723	SCREW, machine; 6-32 x 2 in. (51 mm)	4	111	118433	VALVE, check	1
36		SWITCH, added pole; 380V; page 56 and 58	*	112	118432	VALVE, check	1
37	15B396	WIRE, hose	1	113	116746	FITTING, barbed	2
38	115492	SCREW, machine; 8-32 x 0.345 in. (9 mm)	13	115	15C568	BRACKET, reservoir	1
39		FILTER; 230V; page 56 and 58	*	116	186494	CLIP, spring	1
40	117623	NUT, cap; 3/8-16	4	117	206995	THROAT SEAL LIQUID; 1 qt (1 liter)	1
41	113796	SCREW, flanged, hex hd; 1/4-20 x 3/4 in. (19 mm)	15	119	191892	ELBOW; 1/8 npt (m x f)	2
42	115942	NUT, hex flange; 1/4-20	15	120▲	171001	LABEL, warning	1
44	15B536	LABEL, diagnostic codes	1	121		LABEL; page 57 and 58	*
45	189930	LABEL, caution	3	122		In-rush Current Limiter; page 57 and 58	*
48▲	189285	LABEL, caution	3				
51▲		LABEL, warning; page 57 and 58	*				
52		CABLE, harness, filter; page 57 and 58	*				
53	15B593	SHIELD, membrane switch; pack of 10	1				
57	15B775	COVER, wire access	2				

▲Replacement Warning labels, signs, tags, and cards are available at no cost.

* See quantity on referenced pages.

Parts that Vary by Model

Use the tables on this and the next 2 pages to find parts that vary by model. Find the ref. no. of part in left column, and Reactor model in top row. Intersection is correct part no.

See page 55 for parts common to all models.

Ref. No.	Description	Reactor Models											Qty	
		246024 E-XP1	246025 E-20	246026 E-30	246028 E-XP2	246029 E-XP1	246030 E-20	246031 E-30	246032 E-XP2	246033 E-XP1	246034 E-20	246035 E-30		246036 E-XP2
2	HEATER; pages 59, 35	245962	245975	245962	245963 (qty: 2)	245962	245975	245962	245963 (qty: 2)	245962	245975	245962	245963 (qty: 2)	1
3	MODULE, proportioner; page 61	245956	245956	245957	245959	245956	245956	245957	245959	245956	245956	245957	245959	1
6	CONTROL, motor; page 65	245980	245980	245981	245981	245980	245980	245981	245981	245980	245980	245981	245981	1
8	TRANSFORMER;	15B351	15B351	15B352	15B352	15B351	15B351	15B352	15B352	15B351	15B351	15B352	15B352	1
9	SHIELD	276878	276878	276879	276879	276878	276878	276879	276879	276878	276878	276879	276879	1
14	TUBE, heater, component A	15B481	15B481	15B481	15B685	15B481	15B481	15B481	15B685	15B481	15B481	15B481	15B685	1
15	TUBE, pump, component A	15B367	15B367	15B480	15B686	15B367	15B367	15B480	15B686	15B367	15B367	15B480	15B686	1
16	TUBE, heater, component B	15B483	15B483	15B483	15B687	15B483	15B483	15B483	15B687	15B483	15B483	15B483	15B687	1
17	TUBE, pump, component B	15B369	15B369	15B482	15B688	15B369	15B369	15B482	15B688	15B369	15B369	15B482	15B688	1
21	CONNECTOR, tube	117555	117555	117594	117594	117555	117555	117594	117594	117555	117555	117594	117594	2
28	MODULE, breaker; page 68	246090	246090	246090	246092	246096	246096	246096	246098	246087	246087	246087	246089	1
36	SWITCH, added pole; 380V					117553	117553	117553	117553					1
39	FILTER; 230V			117667	117667			117667	117667			117667	117667	1

Ref. No.	Description	Reactor Models												Qty
		246024 E-XP1	246025 E-20	246026 E-30	246028 E-XP2	246029 E-XP1	246030 E-20	246031 E-30	246032 E-XP2	246033 E-XP1	246034 E-20	246035 E-30	246036 E-XP2	
51▲	LABEL, warning			198278	198278			198278	198278			198278	198278	1
52	CABLE, harness, filter			15B385	15B385			15B385	15B385			15B385	15B385	1
65	ELBOW, swivel; 3/4 npt(m) x 3/4 npt(f)	160327	160327		160327	160327	160327		160327	160327	160327		160327	2
	ELBOW, swivel; 3/4 npt(m) x 1" npt(f)			118463				118463				118463		2
72	BRACKET, heater	15C733	15C733	15C733		15C733	15C733	15C733		15C733	15C733	15C733		2
	BRACKET, heater				15C733				15C733				15C733	4
73	WASHER, lock			103181	103181			103181	103181			103181	103181	2
76	CAPACITOR			244733	244733			244733	244733			244733	244733	1
77	BRACKET			197999	197999			197999	197999			197999	197999	1
86	CABLE, overtemperature, jumper; see pages 59, 60)	15B769	15B769	15B769		15B769	15B769	15B769		15B769	15B769	15B769		2
	CABLE, overtemperature, jumper; see page 60)				15B769				15B769				15B769	4
92	CABLE, harness, power; see pages 68-70	15B511	15B511			15B511	15B511			15B511	15B511			1
	CABLE, harness, power; see pages 68-70			15B382	15B382			15B382	15B382			15B382	15B382	1
96	LOCKWASHER; 3/8	100133	100133	100133		100133	100133	100133		100133	100133	100133		2
	LOCKWASHER; 3/8				100133				100133				100133	4
97	NUT, channel	118446	118446	118446		118446	118446	118446		118446	118446	118446		2
	NUT, channel				118446				118446				118446	4
102	STRAP, motor	15B107	15B107	15B108	15B108	15B107	15B107	15B108	15B108	15B107	15B107	15B108	15B108	1
121	LABEL	15B811	15B537	15B538	15B544	15B811	15B537	15B538	15B544	15B811	15B537	15B538	15B544	1
122*	In-rush Current Limiter; page 54					288359	288359	288359	288359					

* Uses 1.6Amp, Slo-Blow Fuse 120614. **This fuse must be slow blow for In-rush Current Limiter to function properly.**

Reactor Assembly Parts Continued

Ref. No.	Description	Reactor Models			Qty
		248657 E-30 w/15.3 kW	248658 E-30 w/15.3 kW	248659 E-30 w/15.3 kW	
2	HEATER; pages 59, 35	245963	245962	245962	2
3	MODULE, proportioner; page 61	245957	245957	245957	1
6	CONTROL, motor; page 65	245981	245981	245981	1
8	TRANSFORMER;	15B352	15B352	15B352	1
9	SHIELD	276879	276879	276879	1
14	TUBE, heater, component A	15B685	15B685	15B685	1
15	TUBE, pump, component A	15B686	15B686	15B686	1
16	TUBE, heater, component B	15B687	15B687	15B687	1
17	TUBE, pump, component B	15B688	15B688	15B688	1
21	CONNECTOR, tube	117594	117594	117594	2
28	MODULE, breaker; page 68	246090	246089	246098	1
36	SWITCH, added pole; 380V			117553	1
39	FILTER; 230V	117667	117667	117667	1
51▲	LABEL, warning	198278	198278	198278	1
52	CABLE, harness, filter	15B385	15B385	15B385	1
65	ELBOW, swivel; 3/4 npt(m) x 3/4 npt(f)				
	ELBOW, swivel; 3/4 npt(m) x 1" npt(f)	118463	118463	118463	2
72	BRACKET, heater				
	BRACKET, heater	15C733	15C733	15C733	2
73	WASHER, lock	103181	103181	103181	2
76	CAPACITOR	244733	244733	244733	1
77	BRACKET	197999	197999	197999	1
86	CABLE, overtemperature, jumper; see pages 59, 60)				
	CABLE, overtemperature, jumper; see page 60)	15B769	15B769	15B769	4

Ref. No.	Description	Reactor Models			Qty
		248657 E-30 w/15.3 kW	248658 E-30 w/15.3 kW	248659 E-30 w/15.3 kW	
92	CABLE, harness, power; see pages 68-70				
	CABLE, harness, power; see pages 68-70	15B382	15B382	15B382	1
96	LOCKWASHER; 3/8				
	LOCKWASHER; 3/8	100133	100133	100133	4
97	NUT, channel				
	NUT, channel	118446	118446	118446	4
102	STRAP, motor	15B108	15B108	15B108	1
121	LABEL	15B538	15B538	15B538	1
122*	In-rush Current Limiter; page 54			288359	1

* Uses 1.6Amp, Slo-Blow Fuse 120614. **This fuse must be slow blow for In-rush Current Limiter to function properly.**

▲Additional warning labels are available at no cost.

Reactor Frame

245954 Frame

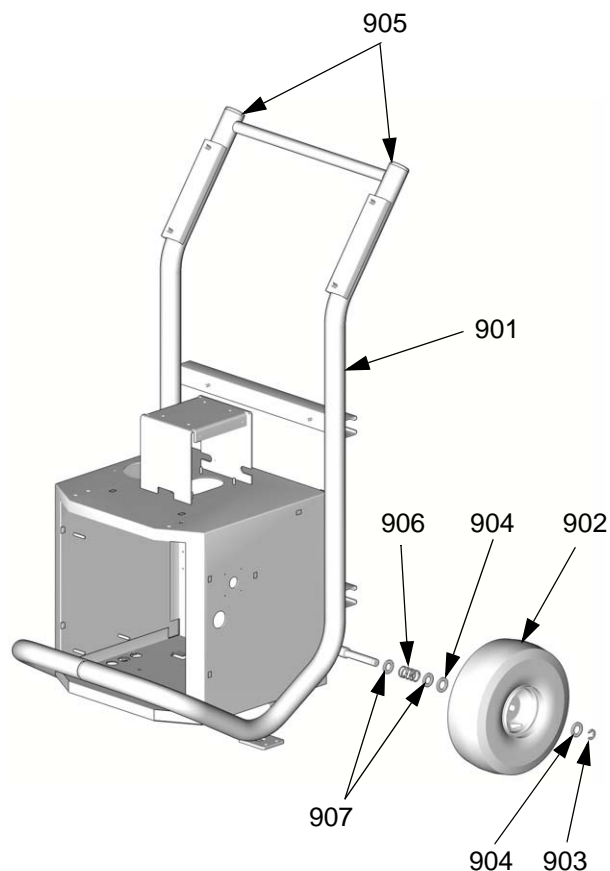

TI2513A

Ref. No.	Part No.	Description
901	246204	FRAME
902	116478	WHEEL
903	101242	RING, retaining
904	116477	WASHER, flat; nylon
905	112125	PLUG
906	116411	SPRING
907	154636	WASHER, flat

Fluid Heater

245962 10.2 kW Heater, for E-30 and E-XP1 Reactor

* Ref. No. 86 not included with heater. Order separately, see page 57.

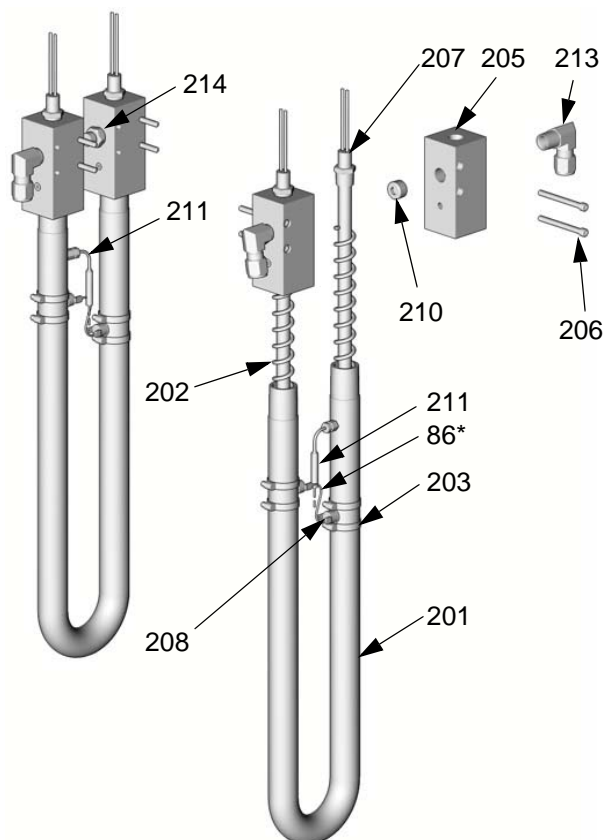

TI2512b

Ref. No.	Part No.	Description	Qty
201	15B134	HOUSING	2
202	15B135	MIXER	4
203	117464	CLAMP	8
205	15B132	MANIFOLD	4
206	107218	SCREW	8
207	15B138	HEATER, immersion; 2550 W; 230v	4
208	15B137	SWITCH, overtemperature	4
210	100361	PLUG	2
211	117484	THERMOCOUPLE	2
213	117532	ELBOW; 1/2 npt x 1/2 in. (13 mm) OD tube	4
214	248187	RUPTURE DISK KIT; see 309969	2

245963 7.65 kW Heater, for E-XP2 and E-30, with 15.3kW of heat, Reactor (2 required)

* Ref. No. 86 not included with heater. Order separately, see page 57.

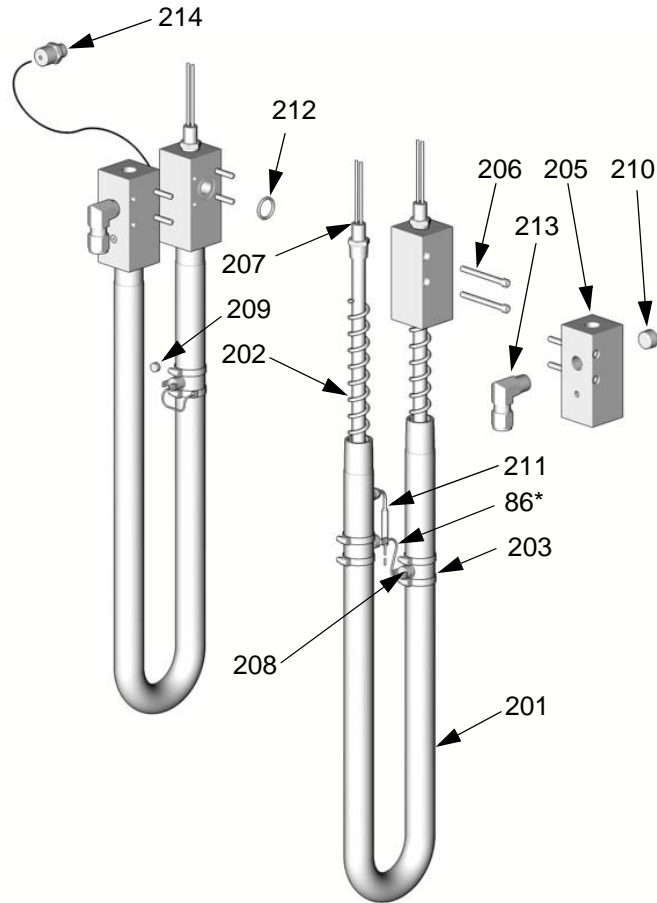

TI2578b

Ref. No.	Part No.	Description	Qty
201	15B134	HOUSING	2
202	15B135	MIXER	3
203	117464	CLAMP	6
204	15B133	CROSSOVER	2
205	15B132	MANIFOLD	2
206	107218	SCREW	8
207	15B138	HEATER, immersion; 2550 W; 230v	3
208	15B137	SWITCH, overtemperature	3
209	100139	PLUG	1
210	100361	PLUG	2
211	117484	THERMOCOUPLE	1
212	117466	O-RING	1
213	117532	ELBOW; 1/2 npt x 1/2 in. (13 mm) OD tube	2
214	248187	RUPTURE DISK KIT; see 309969	1

245975 6 kW Heater, for E-20 Reactor

* Ref. No. 86 not included with heater. Order separately, see page 57.

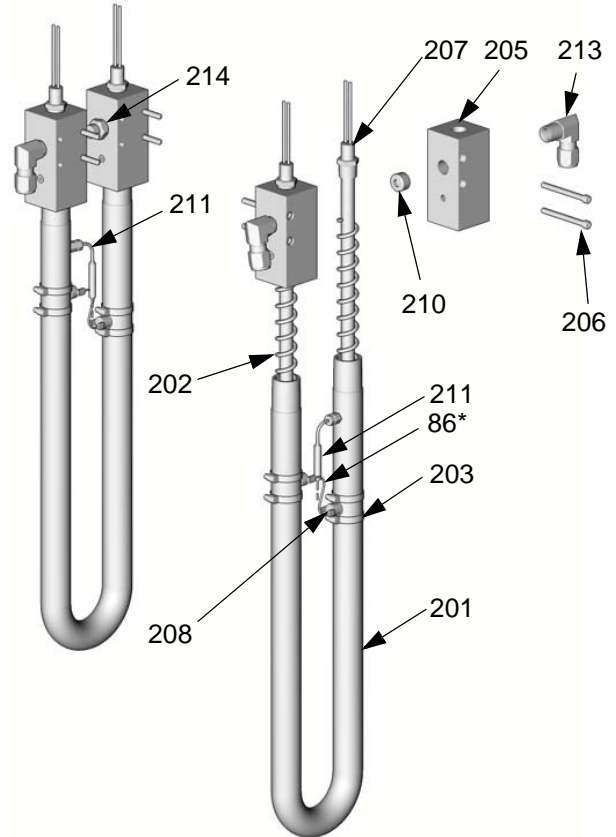

TI2512b

Ref. No.	Part No.	Description	Qty
201	15B134	HOUSING	2
202	15B135	MIXER	4
203	117464	CLAMP	8
205	15B132	MANIFOLD	4
206	107218	SCREW	8
207	15B140	HEATER, immersion; 1500 W; 230v	4
208	15B137	SWITCH, overtemperature	4
210	100361	PLUG	2
211	117484	THERMOCOUPLE	2
213	117532	ELBOW; 1/2 npt x 1/2 in. (13 mm) OD tube	4
214	248187	RUPTURE DISK KIT; see 309969	2

Proportioner Module

245956 Module, for E-20 and E-XP1

245957 Module, for E-30

245959 Module, for E-XP2

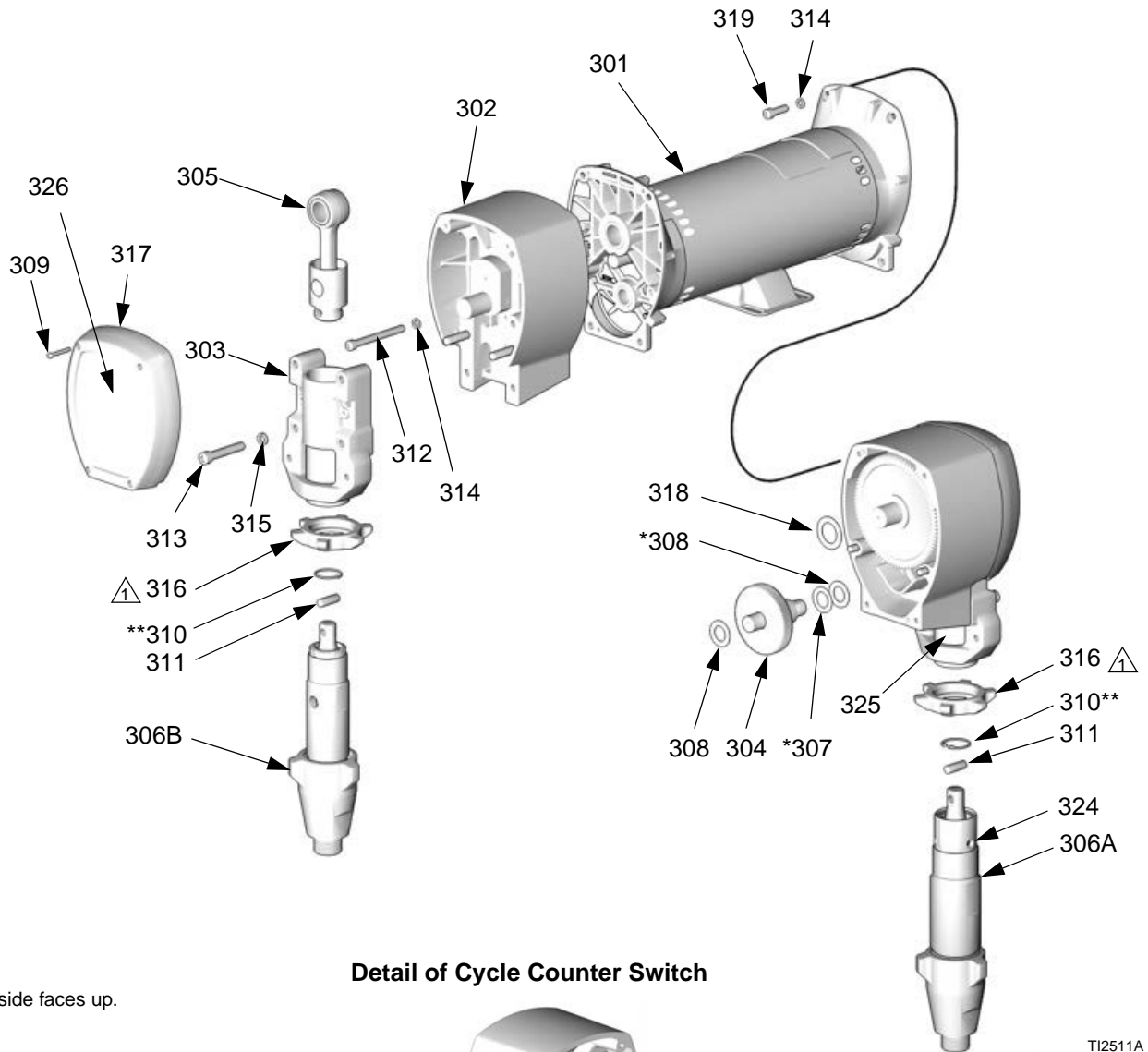

△ Flat side faces up.

Detail of Cycle Counter Switch

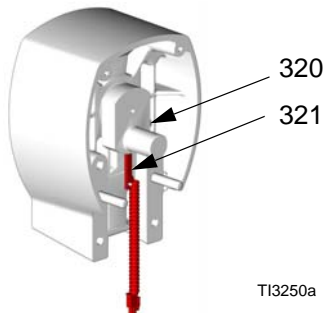

TI3250a

TI2511A

245956 Module, for E-20 and E-XP1**245957 Module, for E-30****245959 Module, for E-XP2**

Ref. No.	Part No.	Description	Qty	Ref. No.	Part No.	Description	Qty
301	245965	MOTOR; 245956	1	323	100643	SCREW, cap, socket-hd; 1/4-20 x 1 in. (25 mm); 245956	4
	245966	MOTOR; 245957, 245959	1		102962	SCREW, cap, socket-hd; 5/16-18 x 1-1/4 in. (31 mm); 245957, 245959	4
302	245968	HOUSING, drive; 245956	2	324	104765	PLUG	2
	245969	HOUSING, drive; 245957, 245959	2	325	15C587	GUARD, finger; 245956	1
303	240523	HOUSING, bearing; 245956	2		15C588	GUARD, finger; 245959	1
	241015	HOUSING, bearing; 245959	2	326	15B532	LABEL; 245956	1
	245927	HOUSING, bearing; 245957	2		15B534	LABEL; 245957, 245959	1
304	244264	GEAR; includes items 307, 308; 245956	2				
	244265	GEAR; includes items 307, 308; 245957, 245959	2	*		<i>Parts included in Gear Kit 244264 (245956) or 244265 (245957, 245959).</i>	
305	241008	ROD, connecting; includes item 310; 245956	2	**		<i>Parts included in Connecting Rod Kit 241008 (245956) or 241279 (245957, 245959).</i>	
	241279	ROD, connecting; includes item 310; 245957, 245959	2				
306A	246830	PUMP, displacement, component A; 245956; see 309577	1				
	246831	PUMP, displacement, component A; 245959; see 309577	1				
	246832	PUMP, displacement, component A; 245957; see 309577	1				
306B	245970	PUMP, displacement, component B; 245956; see 309577	1				
	245971	PUMP, displacement, component B; 245959; see 309577	1				
	245972	PUMP, displacement, component B; 245957; see 309577	1				
307*	114699	WASHER, thrust; steel	2				
308*	114672	WASHER, thrust; bronze	4				
309	114418	SCREW, self-tapping; 8-32 x 1 in. (25 mm); 245956	8				
	114818	SCREW, self-tapping; 8-32 x 1-1/4 in. (31 mm); 245957, 245959	8				
310**	176817	CLIP, wire; 245956	2				
	183169	CLIP, wire; 245957, 245959	2				
311	176818	PIN; 245956	2				
	183210	PIN; 245957, 245959	2				
312	107218	SCREW, cap, socket-hd; 1/4-20 x 2-3/4 in. (70 mm); 245956	4				
	114686	SCREW, cap, socket-hd; 5/16-18 x 3-1/4 in. (83 mm); 245957, 245959	4				
313	107210	SCREW, cap, socket-hd; 3/8-16 x 1-1/2 in. (38 mm); 245956	8				
	114666	SCREW, cap, socket-hd; 3/8-16 x 2-1/4 in. (57 mm); 245957, 245959	8				
314	105510	WASHER, lock; 1/4; 245956	12				
	104008	WASHER, lock; 5/16; 245957, 245959	12				
315	106115	WASHER, lock; 3/8 size	8				
316	192723	NUT, retaining; 245956	2				
	193031	NUT, retaining; 245959	2				
	193394	NUT, retaining; 245957	2				
317	179899	COVER; 245956	2				
	241308	COVER; 245957, 245959	2				
318	116191	WASHER, thrust; 245956	2				
	116192	WASHER, thrust; 245957, 245959	2				
319	100644	SCREW, cap, socket-hd; 1/4-20 x 3/4 in. (19 mm); 245956	4				
	101864	SCREW, cap, socket-hd; 5/16-18 x 1 in. (25 mm); 245957, 245959	4				
320	116618	MAGNET	1				
321	117770	SWITCH, cycle counter	1				

Display

245974 Display

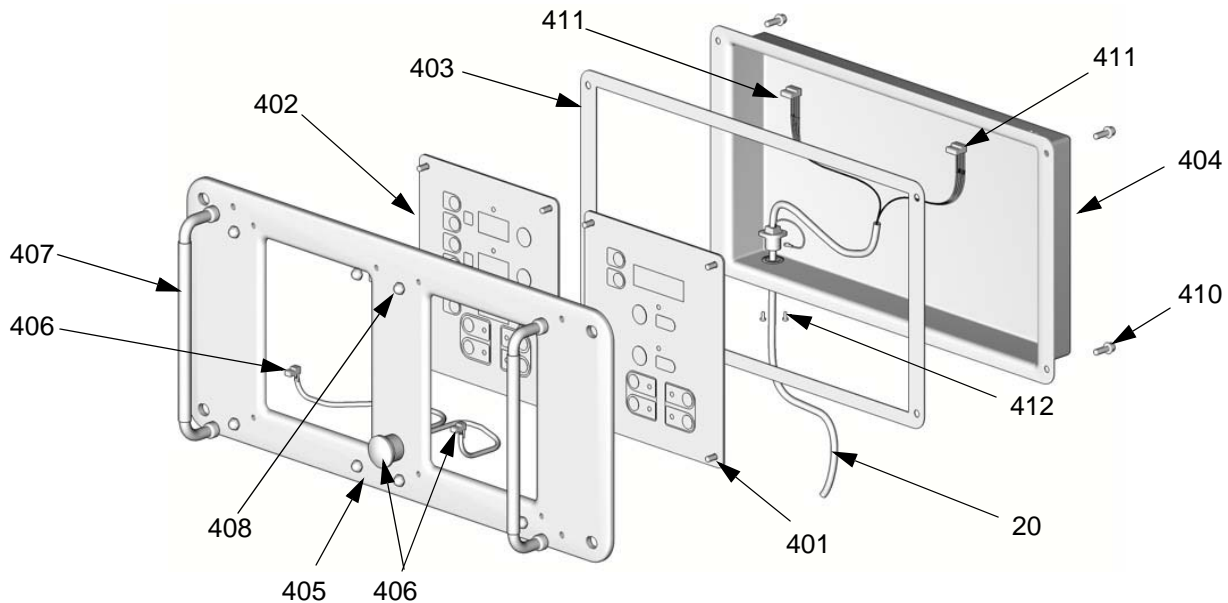

TI2574A

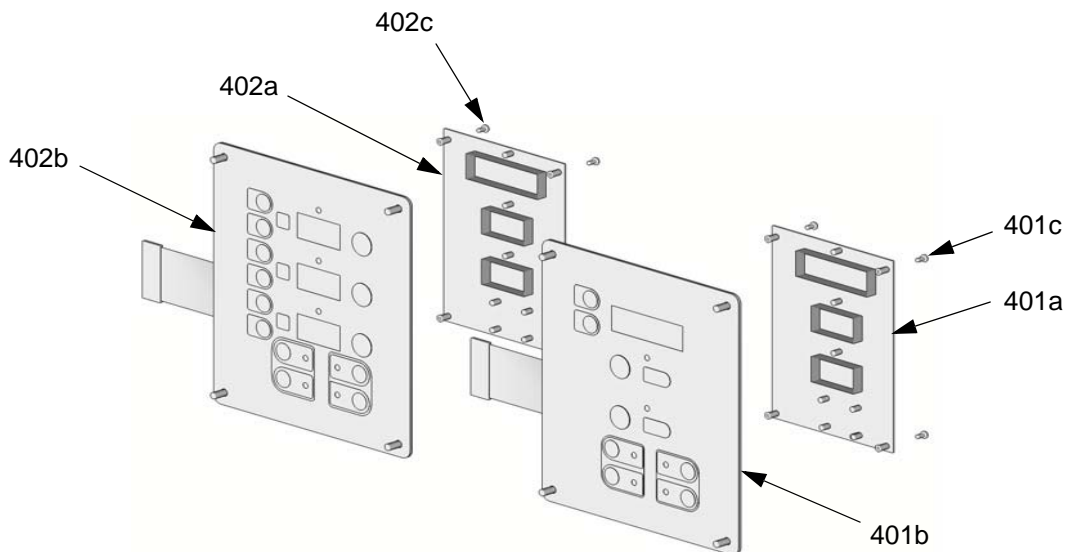

TI3172a

Ref. No.	Part No.	Description	Qty	Ref. No.	Part No.	Description	Qty
401	245978	DISPLAY, pressure; includes 401a-401c	1	406	246287	HARNESS, wire, red stop button	1
401a	246130	. BOARD, circuit	1	407	117499	HANDLE	2
401b	246478	. SWITCH, membrane	1	408	117523	NUT, cap; 10-24	8
401c	112324	. SCREW	4	410		SCREW, machine, pan-hd; M5 x 0.8; 16 mm	4
402	245977	DISPLAY, temperature; includes 402a-402c	1	411	15B386	CABLE, display	1
402a	246130	. BOARD, circuit	1	412	195853	SCREW, machine; M2.5 x 6	2
402b	246479	. SWITCH, membrane	1				
402c	112324	. SCREW	4				
403	15B293	GASKET	1				
404	15B292	COVER	1				
405	15B291	PLATE	1				

Temperature Control

245979 Temperature Control

 Apply 110009 thermal heatsink compound to mating surfaces.

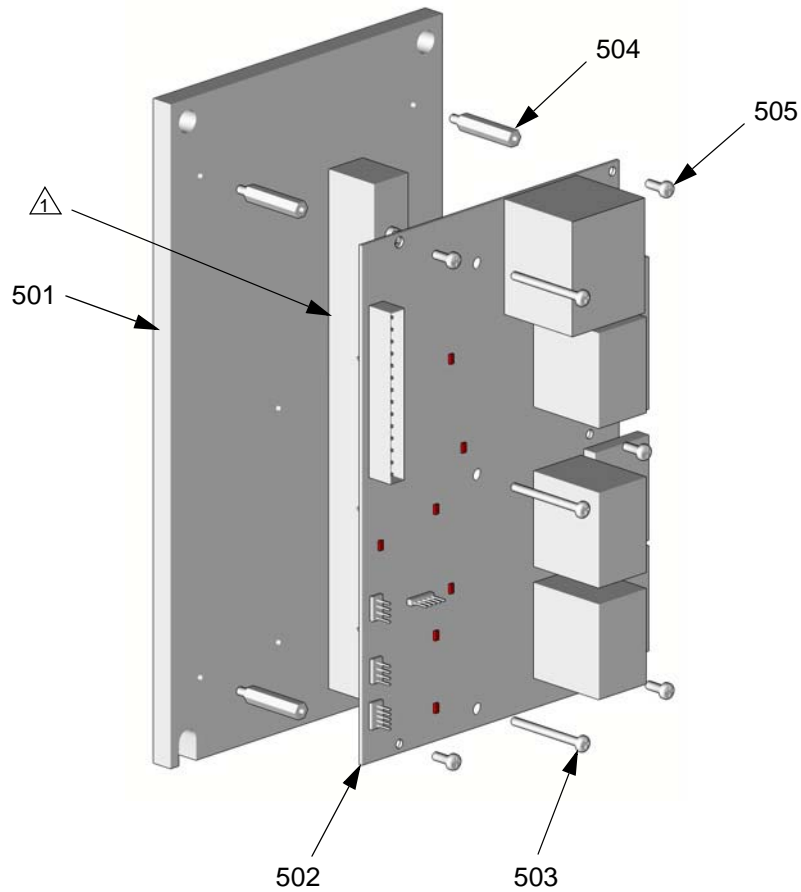

TI2575A-1

Ref. No.	Part No.	Description	Qty
501	15B779	HEAT SINK	1
502	246194	BOARD, temperature control	1
503	117683	SCREW, 6-32 x 1-1/2 in. (38 mm)	2
504	117526	SPACER	5
505		SCREW, machine; 6-32 x 3/8 in. (10 mm)	5

Motor Control

245980 Motor Control, for E-20 and E-XP1

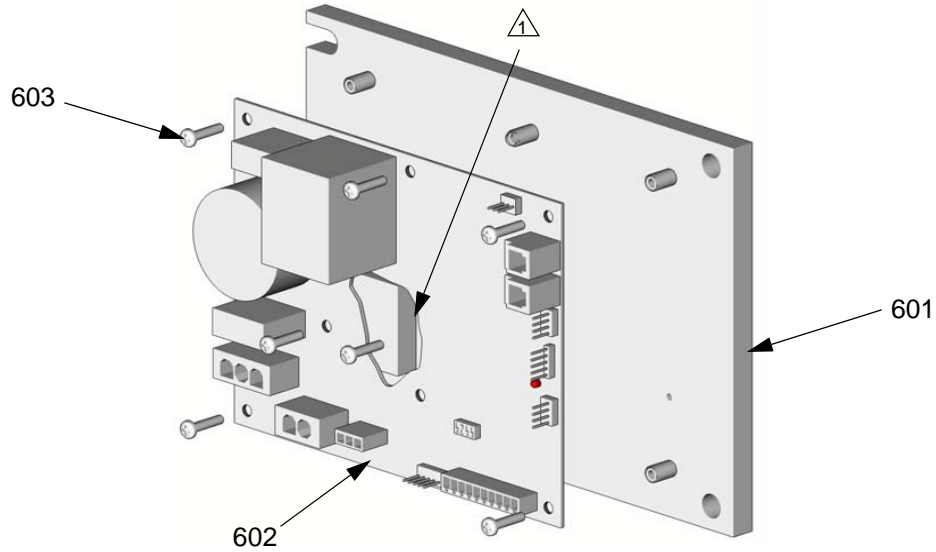

 Apply 110009 thermal heatsink compound to mating surfaces.

TI3153A

Ref. No.	Part No.	Description	Qty
601	15B297	HEAT SINK	1
602	246195	BOARD, motor control	1
603	107156	SCREW, machine; 6-32	7

245981 Motor Control, for E-30 and E-XP2

 Apply 110009 thermal heatsink compound to mating surfaces.

 Motor harness (609) plugs in here.

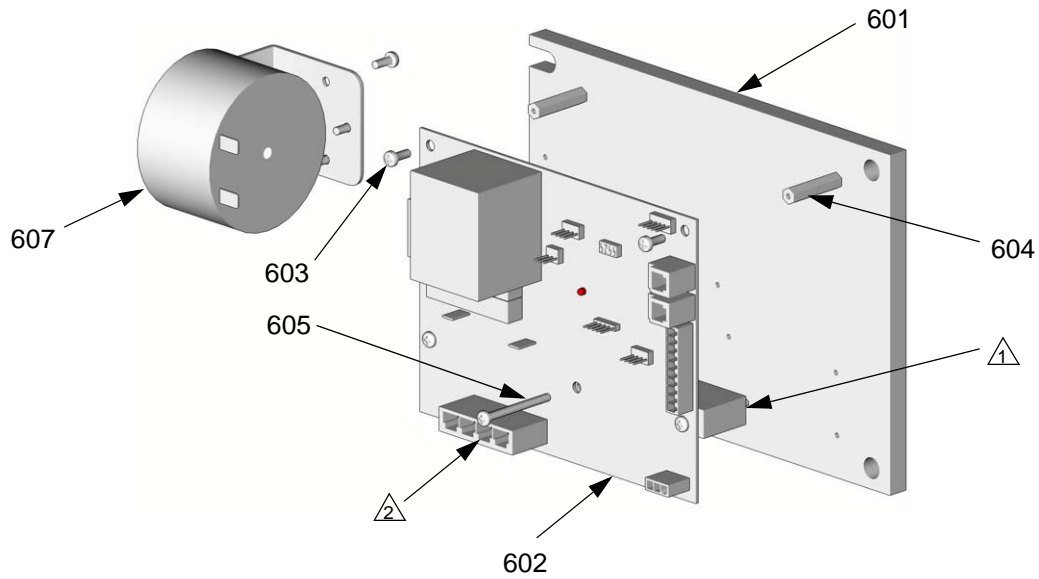

TI2576A

Ref. No.	Part No.	Description	Qty
601	15B297	HEAT SINK	1
602	246196	BOARD, motor control	1
603		SCREW, machine; 6-32 x 3/8 in. (10 mm)	6
604	117526	SPACER	3
605	117683	SCREW, 6-32 x 1-1/2 in. (38 mm)	2
607	15C007	INDUCTOR	1
609	15B408	CABLE, harness, motor	1

Fluid Manifold

246154 Fluid Manifold

- ① Apply 113500 thread lock (blue).
- ② Torque to 355-395 in-lb (40.1-44.6 N•m).
- ③ Apply PTFE tape or thread sealant to tapered threads.
- ④ Torque to 175-195 in-lb (19.8-22.0 N•m).
- ⑤ Lubricate ends of spring when assembling.
- ⑥ Assemble valves (702) and handles (709) with handles facing away from each other.
- ⑦ Assemble seat (707) with lapped seat facing valve (702).
- ⑧ Apply grease (118665) to seat (707) and seal (708) prior to inserting into valve (702) to aid retention during assembly to manifold (701).

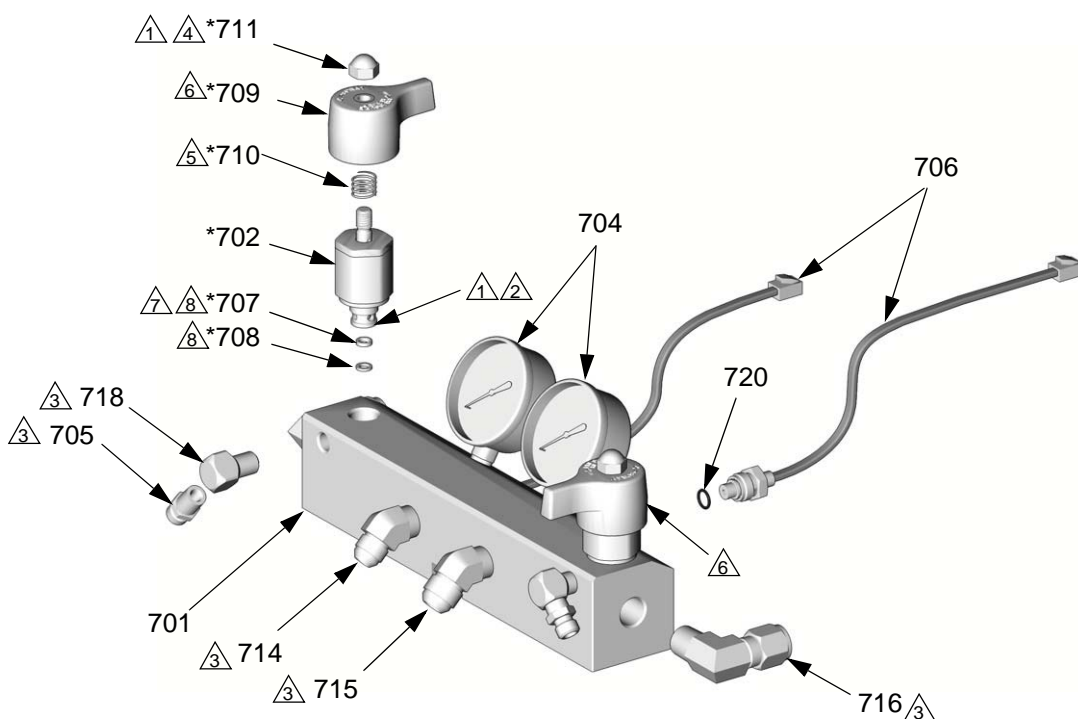

TI2573A

Ref. No.	Part No.	Description	Qty
701	15B332	MANIFOLD; aluminum	1
702*	246161	VALVE, pressure relief/spray	2
704	102814	GAUGE; 5000 psi (35 MPa, 350 bar)	2
705	162453	NIPPLE; 1/4 npt x 1/4 npsm	2
706	24K999	TRANSDUCER, pressure control	2
707*	193709	SEAT, valve; carbide	2
708*	193710	SEAL, seat; nylon	2
709*	15B287	HANDLE, valve	2
710*	114708	SPRING	2
711*	117623	NUT, cap; 3/8-16	2
714	117556	ELBOW, 45°; #8 JIC x 1/2 npt	1

Ref. No.	Part No.	Description	Qty
715	117557	ELBOW, 45°; #10 JIC x 1/2 npt	1
716	117532	ELBOW; 1/2 npt(m) x 1/2 in. (13 mm) OD tube	2
718	100840	ELBOW, street; 1/4 npsm x 1/4 npt	2
720	111457	O-RING; PTFE	2
721▲	189285	LABEL, caution	1

* Included in Repair Kit 246842 (purchase separately).

▲ Replacement Warning labels, signs, tags, and cards are available at no cost.

Circuit Breaker Modules

230V, 3 Phase Circuit Breaker Modules

 For wiring and cable connections, refer to electrical diagrams supplied. See page 71 for parts list.

Part No. 246087 (E-20, E-30, E-XP1)

* Ref. No. 92 not included with module. Order separately, see page 57.

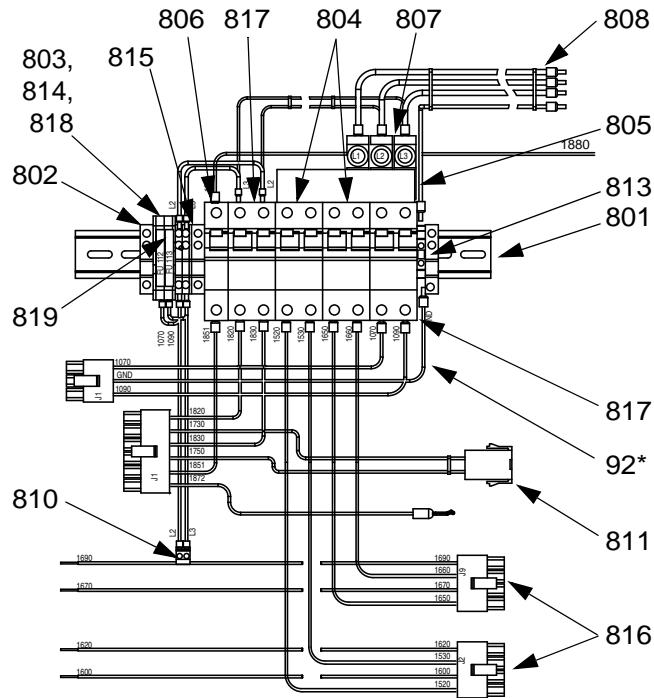

Part No. 246089 (E-XP2)

* Ref. No. 92 not included with module. Order separately, see page 57.

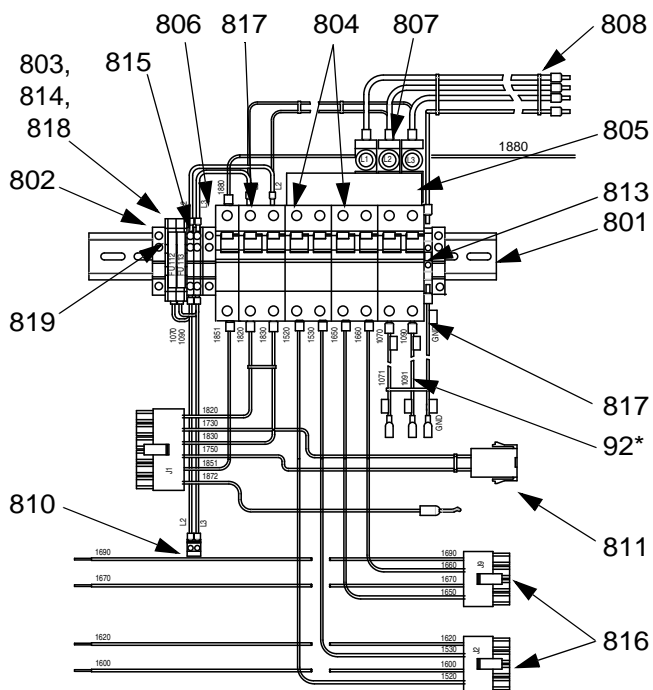

230V, 1 Phase Circuit Breaker Modules

 For wiring and cable connections, refer to electrical diagrams supplied. See page 71 for parts list.

Part No. 246090 (E-20, E-30, E-XP1)

* Ref. No. 92 not included with module.
Order separately, see page 57.

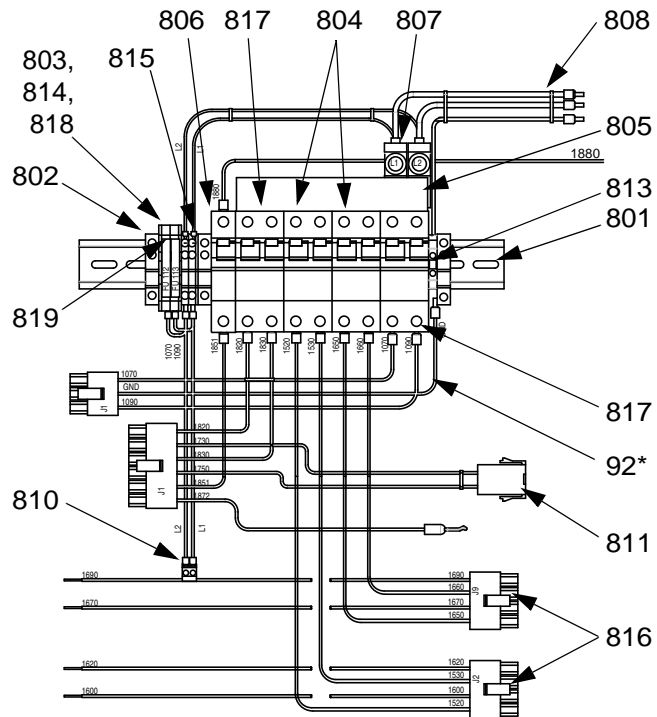

Part No. 246092 (E-XP2)

* Ref. No. 92 not included with module.
Order separately, see page 57.

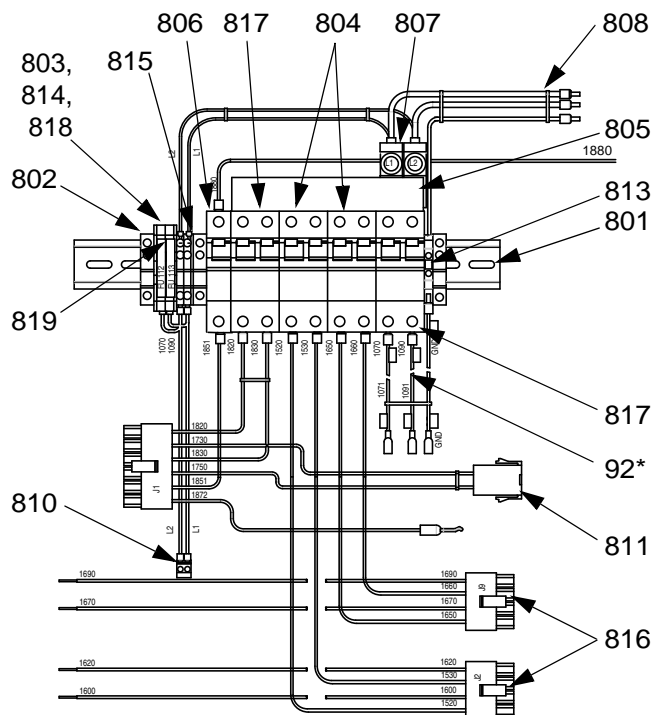

380V, 3 Phase Circuit Breaker Modules

 For wiring and cable connections, refer to electrical diagrams supplied. See page 71 for parts list.

Part No. 246096 (E-20, E-30, E-XP1)

* Ref. No. 92 not included with module.
Order separately, see page 57.

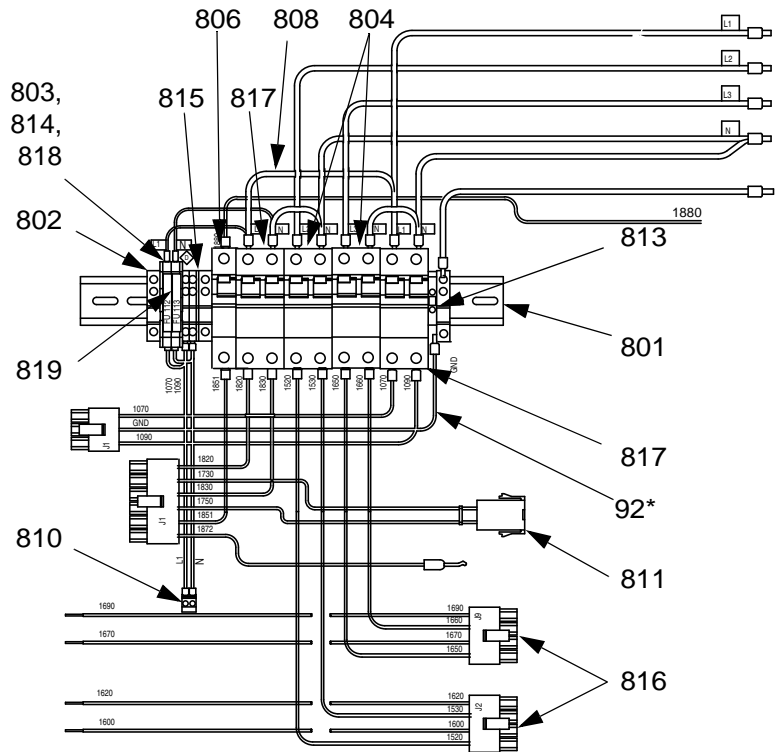

Part No. 246098 (E-XP2)

* Ref. No. 92 not included with module.
Order separately, see page 57.

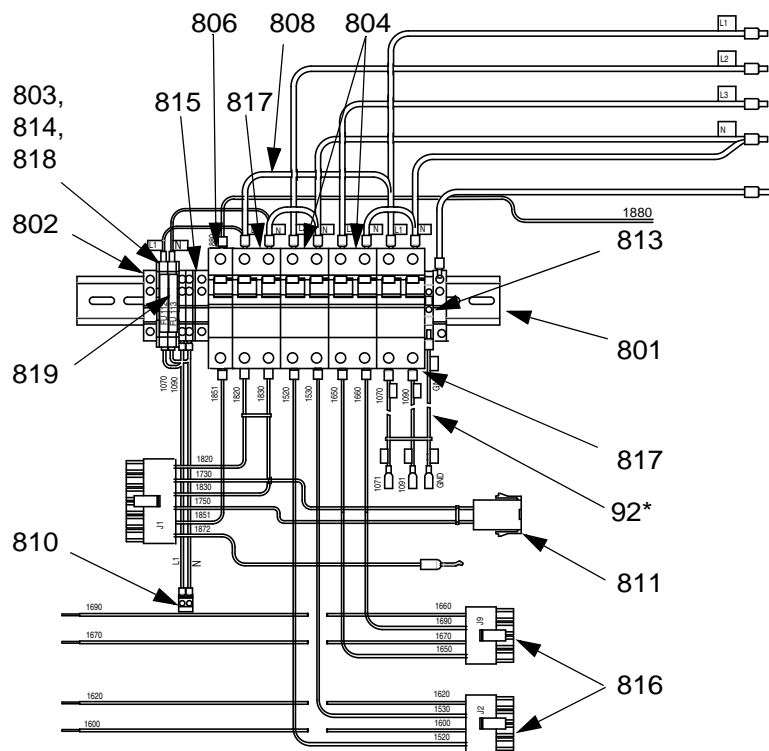

Circuit Breaker Modules Parts List

Ref. No.	Description	Breaker Modules									Qty
		246087 230V, 3 θ	246087 230V, 3 θ (E-30 only)	246089 230V, 3 θ	246090 230V, 1 θ	246090 230V, 1 θ (E-30 only)	246092 230V, 1 θ	246096 380V, 3 θ	246096 380V, 3 θ (E-30 only)	246098 380V, 3 θ	
801	RAIL, mounting	buy locally	buy locally	buy locally	buy locally	buy locally	buy locally	buy locally	buy locally	buy locally	1
802	CLAMP, end	112446	112446	112446	112446	112446	112446	112446	112446	112446	3
803	TERMINAL, base, fuse plug	117798	117798	117798	117798	117798	117798	117798	117798	117798	2
804	BREAKER, dual; 25A	117591	117591		117591	117591		117591	117591		2
	BREAKER, dual; 40A			117505			117505			117505	2
805	BAR, power buss, 3 θ	117805	117805	117805							1
	BAR, power buss, 1 θ				117678	117678	117678				1
806	BREAKER, single; 50A	117503	117503	117503	117503	117503	117503	117503	117503	117503	1
807	CONNECTOR, power lug	117679	117679	117679							3
	CONNECTOR, power lug				117679	117679	117679				2
808	CABLE, harness; 230V, 3 θ	15B387	15B387	15B387							1
	CABLE, harness; 230V, 1 θ				117674	117674	117674				1
	CABLE, harness; 380V, 3 θ							15B377	15B377	15B377	1
810	CABLE, harness, power temp	15B375	15B375	15B375	15B375	15B375	15B375	15B375	15B375	15B375	1
811	CABLE, hose, heat	15B378	15B378	15B378	15B378	15B378	15B378	15B378	15B378	15B378	1
813	BLOCK, terminal ground	112443	112443	112443	112443	112443	112443	112443	112443	112443	1
814	FUSE, fan; 5 x 20 mm Bussman GDA-2A or equivalent	115216	115216	115216	115216	115216	115216	115216	115216	115216	2
815	TERMINAL, end cover	117807	117807	117807	117807	117807	117807	117807	117807	117807	1
816	CABLE, harness, heat A/B	15B376	15B376	15B376	15B376	15B376	15B376	15B376	15B376	15B376	2
817	BREAKER, dual; 20A	117711	117711	117711	117711	117711	117711	117711	117711	117711	2
818	TERMINAL, end cover	117797	117797	117797	117797	117797	117797	117797	117797	117797	1
819	FUSE, plug	117799	117799	117799	117799	117799	117799	117799	117799	117799	2

* Not included with module. Order separately.

248669 Conversion Kit

Convert and phase E-XP2 to an E-30 with 15.3kW of heat by changing pump lowers, bearings, and changing the Motor Control DIP settings to that of an E-30. For removal and installation of pump lowers and bearings, see **Pump Removal**, page 24. For changing Motor Control DIP settings, see **Motor Control Board**, page 34.

Ref. No.	Part No.	Description	Qty
65	118463	ELBOW, swivel; 3/4 npt(m) x 1 in. npt(f)	2
303	245927	HOUSING, bearing	2
306A	246832	PUMP, displacement, component A; see 309557	1
306B	245972	PUMP, displacement, component B; see 309577	1
316	193394	NUT, retaining	2

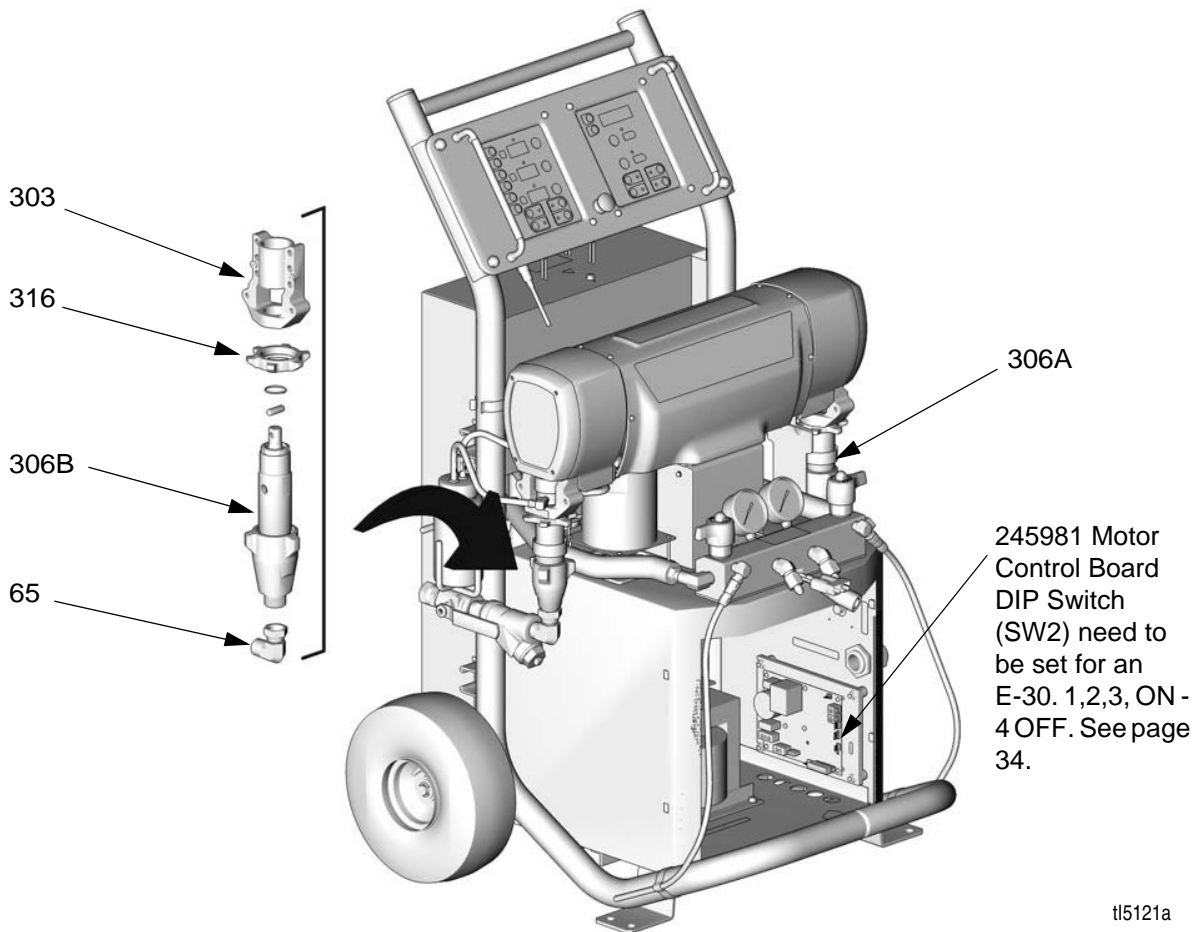

Technical Data

Category	Data
Maximum Fluid Working Pressure	Models E-20 and E-30: 2000 psi (14 MPa, 140 bar) Model E-XP1: 2500 psi (17.2 MPa, 172 bar) Model E-XP2: 3500 psi (24.1 MPa, 241 bar)
Maximum Fluid Temperature	190°F (88°C)
Maximum Output	Model E-20: 20 lb/min (9 kg/min) Model E-30: 30 lb/min (13.5 kg/min) Model E-XP1: 1 gpm (3.8 liter/min) Model E-XP2: 2 gpm (7.6 liter/min)
Output per Cycle (A and B)	Model E-20 and E-XP1: .0104 gal. (.0395 liter) Model E-30: .0272 gal. (0.1034 liter) Model E-XP2: .0203 gal. (.0771 liter)
Line Voltage Requirement	Part Nos. 246024, 246025, 246026, 246028, 248657: 195-264 Vac, 50/60 Hz Part Nos. 246029, 246030, 246031, 246032, 248659: 338-457 Vac, 50/60 Hz Part Nos. 246033, 246034, 246035, 246036, 248658: 195-264 Vac, 50/60 Hz
Amperage Requirement	See page 3.
Heater Power	Model E-20: 6000 Watts Model E-30 and E-XP1: 10200 Watts Models E-XP2 and E-30 with 15.3kW of heat: 15300 Watts
Sound Power, per ISO 9614-2	Model E-20: 80 dB(A) at 2000 psi (14 MPa, 140 bar), 0.5 gpm (1.9 lpm) Model E-30: 93.5 dB(A) at 1000 psi (7 MPa, 70 bar), 3.0 gpm (11.4 lpm) Model E-XP1: 80 dB(A) at 2000 psi (14 MPa, 140 bar), 0.5 gpm (1.9 lpm) Model E-XP2: 83.5 dB(A) at 3000 psi (21 MPa, 210 bar), 1.0 gpm (3.8 lpm)
Sound Pressure, 1 m from equipment	Model E-20: 70.2 dB(A) at 2000 psi (14 MPa, 140 bar), 0.5 gpm (1.9 lpm) Model E-30: 83.6 dB(A) at 1000 psi (7 MPa, 70 bar), 3.0 gpm (11.4 lpm) Model E-XP1: 70.2 dB(A) at 2000 psi (14 MPa, 140 bar), 0.5 gpm (1.9 lpm) Model E-XP2: 73.6 dB(A) at 3000 psi (21 MPa, 210 bar), 1.0 gpm (3.8 lpm)
Fluid Inlets	3/4 npt(f), with 3/4 npsm(f) union
Fluid Outlets	Component A (ISO): #8 JIC (3/4-16 unf), with #5 JIC adapter Component B (RES): #10 JIC (7/8-14 unf), with #6 JIC adapter
Fluid Circulation Ports	1/4 npsm(m), with plastic tubing
Weight	Model E-20 and E-XP1: 342 lb (155 kg) Model E-30: 400 lb (181 kg) Models E-XP2 and E-30 with 15.3kW of heat: 438 lb (198 kg)
Wetted Parts	Aluminum, stainless steel, carbon steel, brass, carbide, chrome, chemically resistant o-rings, PTFE, ultra-high molecular weight polyethylene

Loctite® is a registered trademark of the Loctite Corporation.

Graco Standard Warranty

Graco warrants all equipment referenced in this document which is manufactured by Graco and bearing its name to be free from defects in material and workmanship on the date of sale to the original purchaser for use. With the exception of any special, extended, or limited warranty published by Graco, Graco will, for a period of twelve months from the date of sale, repair or replace any part of the equipment determined by Graco to be defective. This warranty applies only when the equipment is installed, operated and maintained in accordance with Graco's written recommendations.

This warranty does not cover, and Graco shall not be liable for general wear and tear, or any malfunction, damage or wear caused by faulty installation, misapplication, abrasion, corrosion, inadequate or improper maintenance, negligence, accident, tampering, or substitution of non-Graco component parts. Nor shall Graco be liable for malfunction, damage or wear caused by the incompatibility of Graco equipment with structures, accessories, equipment or materials not supplied by Graco, or the improper design, manufacture, installation, operation or maintenance of structures, accessories, equipment or materials not supplied by Graco.

This warranty is conditioned upon the prepaid return of the equipment claimed to be defective to an authorized Graco distributor for verification of the claimed defect. If the claimed defect is verified, Graco will repair or replace free of charge any defective parts. The equipment will be returned to the original purchaser transportation prepaid. If inspection of the equipment does not disclose any defect in material or workmanship, repairs will be made at a reasonable charge, which charges may include the costs of parts, labor, and transportation.

THIS WARRANTY IS EXCLUSIVE, AND IS IN LIEU OF ANY OTHER WARRANTIES, EXPRESS OR IMPLIED, INCLUDING BUT NOT LIMITED TO WARRANTY OF MERCHANTABILITY OR WARRANTY OF FITNESS FOR A PARTICULAR PURPOSE.

Graco's sole obligation and buyer's sole remedy for any breach of warranty shall be as set forth above. The buyer agrees that no other remedy (including, but not limited to, incidental or consequential damages for lost profits, lost sales, injury to person or property, or any other incidental or consequential loss) shall be available. Any action for breach of warranty must be brought within two (2) years of the date of sale.

GRACO MAKES NO WARRANTY, AND DISCLAIMS ALL IMPLIED WARRANTIES OF MERCHANTABILITY AND FITNESS FOR A PARTICULAR PURPOSE, IN CONNECTION WITH ACCESSORIES, EQUIPMENT, MATERIALS OR COMPONENTS SOLD BUT NOT MANUFACTURED BY GRACO. These items sold, but not manufactured by Graco (such as electric motors, switches, hose, etc.), are subject to the warranty, if any, of their manufacturer. Graco will provide purchaser with reasonable assistance in making any claim for breach of these warranties.

In no event will Graco be liable for indirect, incidental, special or consequential damages resulting from Graco supplying equipment hereunder, or the furnishing, performance, or use of any products or other goods sold hereto, whether due to a breach of contract, breach of warranty, the negligence of Graco, or otherwise.

FOR GRACO CANADA CUSTOMERS

The Parties acknowledge that they have required that the present document, as well as all documents, notices and legal proceedings entered into, given or instituted pursuant hereto or relating directly or indirectly hereto, be drawn up in English. Les parties reconnaissent avoir convenu que la rédaction du présente document sera en Anglais, ainsi que tous documents, avis et procédures judiciaires exécutés, donnés ou intentés, à la suite de ou en rapport, directement ou indirectement, avec les procédures concernées.

Graco Information

For the latest information about Graco products, visit www.graco.com.

TO PLACE AN ORDER, contact your Graco distributor or call to identify the nearest distributor.

Phone: 612-623-6921 **or Toll Free:** 1-800-328-0211 **Fax:** 612-378-3505

*All written and visual data contained in this document reflects the latest product information available at the time of publication.
Graco reserves the right to make changes at any time without notice.*

Original instructions. This manual contains English. MM 309574

Graco Headquarters: Minneapolis

International Offices: Belgium, China, Japan, Korea

GRACO INC. AND SUBSIDIARIES • P.O. BOX 1441 • MINNEAPOLIS MN 55440-1441 • USA

Copyright 2003, Graco Inc. All Graco manufacturing locations are registered to ISO 9001.

www.graco.com

Revision P, July 2017