

# RTX 1500 Electric Texture Sprayer

310645E

## - For Water-Based Materials Only -

(Consult your Material Supplier for Warnings and Application Requirements)

### Models: *Page 3*

*Maximum Working Air Pressure: 45 psi (3.1 bar)*

*Maximum Working Fluid Pressure: 100 psi (6.9 bar)*



Read all warnings and instructions.

<b>CAUTION</b>
Use RTX 1500 non-bleeder texture gun (model 248091) only. All other guns will damage sprayer.

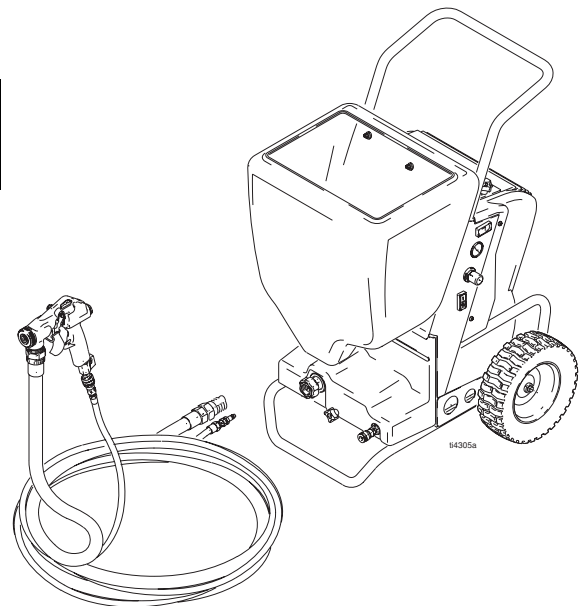

Graco Inc. P.O. Box 1441 Minneapolis, MN 55440-1441

[www.graco.com](http://www.graco.com)

Copyright 2004



Graco Inc. is registered to I.S. EN ISO 9001

PROVEN QUALITY. LEADING TECHNOLOGY.







## Models

Model	Electric Requirements	Country	Manual			Languages
			 Operation	287328*	 Gun	
248201	120V, 60 Hz, 15 A	N. America	310624	310694	310616	English
248370 / 248315	230V, 50 Hz, 10 A	Europe	310624		310616	French
248370	230V, 50 Hz, 10 A	Europe	310624			Dutch
248370	230V, 50 Hz, 10 A	Europe	310625		310616	Spanish
248370 / 248315	230V, 50 Hz, 10 A	Europe	310625			Italian
248370	230V, 50 Hz, 10 A	Europe	310625			Portuguese
248370 / 248315	230V, 50 Hz, 10 A	Europe	310625			German
248315	230V, 50 Hz, 10 A	Europe	310697			Swiss
248315	230V, 50 Hz, 10 A	Europe	310697			Danish
248370	230V, 50 Hz, 10 A	Europe	310697			Norwegian
248370	230V, 50 Hz, 10 A	Europe	310697			Swedish
248370	230V, 50 Hz, 10 A	Europe	310698			Polish
248370	230V, 50 Hz, 10 A	Europe	310698			Russian
248370	230V, 50 Hz, 10 A	Europe	310698			Greek
248315	230V, 50 Hz, 10 A	Asia	310699			Chinese
248315	230V, 50 Hz, 10 A	Asia	310699			Japanese
248315	230V, 50 Hz, 10 A	Asia	310699			Korean
248315	230V, 50 Hz, 10 A	Australia	310699	310694	310616	English

\*Auxiliary Air Hookup Kit

## RELATED MANUALS

Model	Country		Manual	Languages
ALL	ALL		310645	English





The following are general Warnings related to the safe setup, use, maintenance and repair of this equipment. Additional, more specific warnings may be found throughout the text of this manual where applicable.





**Warning**

 <b>WARNING</b>
<p>This symbol alerts you to the possibility of serious injury or death if you do not follow the instructions.</p>

**Caution**

<b>CAUTION</b>
<p>Alerts you to the possibility of damage or destruction of equipment if you do not follow the instructions.</p>

 <b>Warnings</b>	
	<p><b>Fire and Explosion Hazard</b> Flammable fumes, such as solvent and paint fumes, in work area can ignite or explode. To help prevent fire and explosion:</p> <ul style="list-style-type: none"> <li>• Use equipment only in well ventilated area.</li> <li>• Keep work area free of debris, including solvent, rags, and gasoline.</li> <li>• Ground equipment in the work area. See <b>Grounding</b> instructions.</li> <li>• If there is static sparking or you feel a shock, <b>stop operation immediately</b>. Do not use equipment until you identify and correct the problem.</li> </ul>
	<p><b>Equipment Misuse Hazard</b> Equipment misuse can cause death or serious injury.</p> <ul style="list-style-type: none"> <li>• Do not exceed maximum working pressure or temperature rating of lowest rated system component. See <b>Technical Data</b>, in all equipment manuals.</li> <li>• Use fluids and solvents that are compatible with equipment wetted parts. See <b>Technical Data</b> in all equipment manuals. Read fluid and solvent manufacturer’s warnings.</li> <li>• Check equipment daily. Repair or replace worn or damaged parts immediately.</li> <li>• Do not alter or modify this equipment.</li> <li>• Use the equipment only for its intended purpose. Call your Graco distributor for information.</li> <li>• For professional use only.</li> <li>• Route hoses away from traffic areas, sharp edges, moving parts and hot surfaces.</li> <li>• Do not use hoses to pull equipment.’</li> <li>• <a href="#">Keep children and animals away from work area.</a></li> <li>• Comply with all applicable safety regulations.</li> </ul>
	<p><b>Electric Shock Hazard</b> Improper grounding, setup, or usage of the system can cause electric shock.</p> <ul style="list-style-type: none"> <li>• Turn off and disconnect power cord before servicing equipment.</li> <li>• Use only grounded electrical outlets.</li> <li>• Use only 3-wire extension cords.</li> <li>• Ensure ground prongs are intact on sprayer and extension cords.</li> </ul>

<b>WARNINGS</b>	
 	<p><b>Pressurized Equipment Hazard</b> Compressed air can inject in skin. Air tubing rupture can cause injury if disconnected while under pressure. To reduce risk of injury:</p> <ul style="list-style-type: none"> <li>• Never exceed maximum working pressure of any attachment.</li> <li>• Do not direct airstream at body.</li> <li>• Follow <b>Pressure Relief Procedure</b>, page 8 whenever you are instructed to relieve pressure, stop spraying, service equipment, install or clean spray nozzle or disconnect or connect hose.</li> </ul>
	<p><b>Cleaning Solvent Hazard with Plastic Parts</b> Use only compatible water-based solvents to clean plastic structural or pressure-containing parts. Many solvents can degrade plastic parts to the point where they could fail. Such failure could cause serious injury or property damage. See <b>Technical Data</b> on page 35 of this instruction manual and in all other equipment manuals. Read fluid and solvent manufacturer's warnings.</p>
	<p><b>Moving Parts Hazard</b> Moving parts can pinch or amputate fingers and other body parts.</p> <ul style="list-style-type: none"> <li>• Keep clear of moving parts.</li> <li>• Do not operate equipment with protective guards or covers removed.</li> <li>• Pressurized equipment can start without warning. Before checking, moving, or servicing equipment, follow the <b>Pressure Relief Procedure</b> in this manual. Disconnect power or air supply.</li> </ul>
	<p><b>Personal Protective Equipment</b> Wear appropriate protective equipment when operating, servicing or when in the operating area of this equipment to help protect yourself from serious injury, including eye injury, inhalation of toxic fumes, burns and hearing loss. This equipment includes, but is not limited to:</p> <ul style="list-style-type: none"> <li>• protective eye wear</li> <li>• clothing and respirator as recommended by fluid and solvent manufacturer</li> <li>• hearing protection</li> <li>• gloves</li> </ul>

<b>CAUTION</b>
<p>Water or material remaining in unit when temperatures are <b>below freezing</b> can damage pump and/or delay startup.</p> <p>To insure water and material are completely drained out of unit:</p> <ul style="list-style-type: none"> <li>• remove hose from material outlet,</li> <li>• tip sprayer forward 45° to allow material (water) to flow out of pump inlet.</li> </ul> <p>Before adding material or starting unit in cold weather, circulate warm water through pump.</p>

# Component Identification

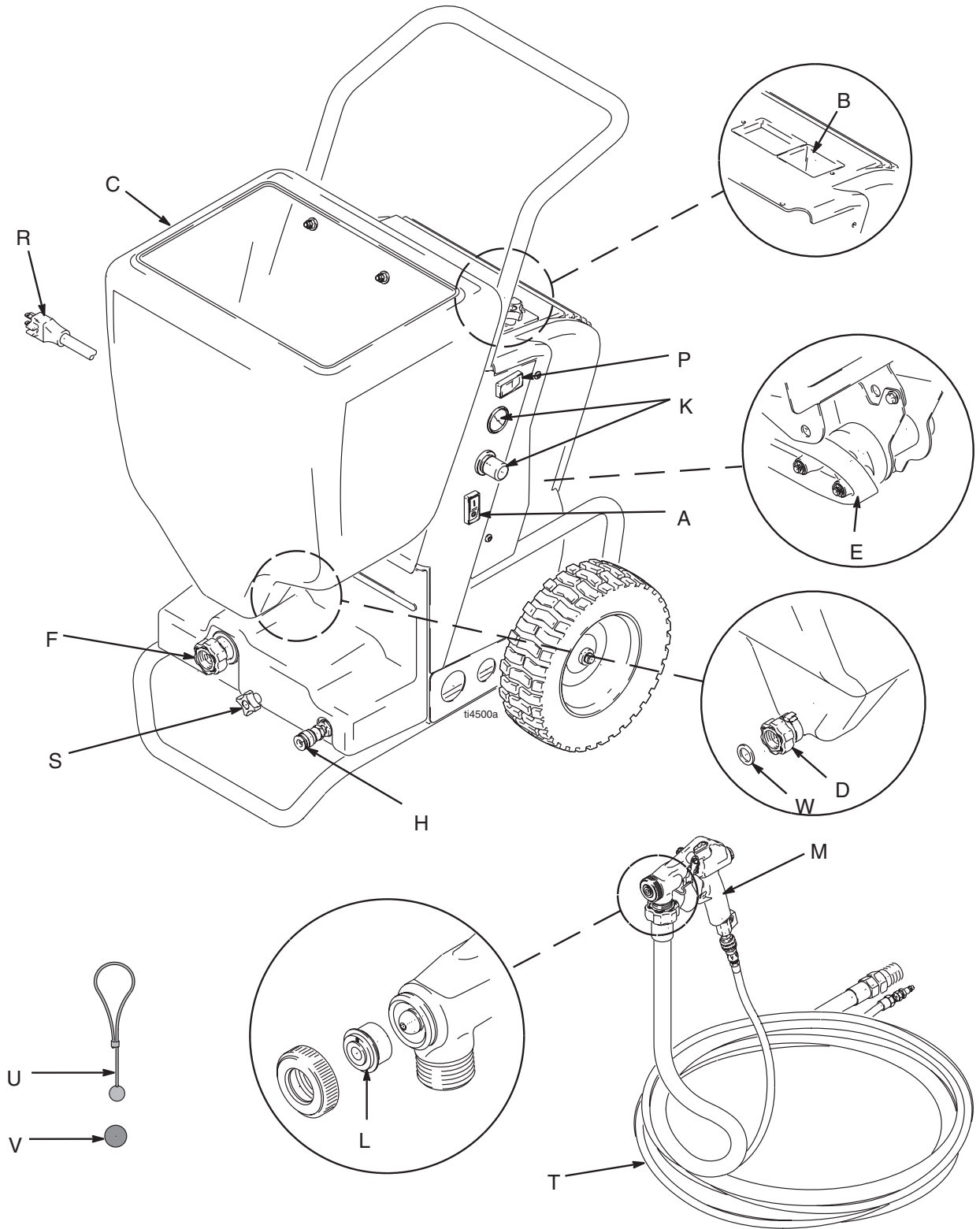

## Component Identification

ITEM	COMPONENT
A	Main Power Switch
B	Nozzle Storage
C	Hopper
D	Hopper Connect/Disconnect
E	Graco RotoFlex™ HD Pump
F	Material Outlet
H	Air Outlet
K	Fluid Flow Regulator and Pressure Gauge
L	Gun Nozzle (5 sizes)
M	Gun (see manual 310616)*
P	Prime Switch
R	Power Cord
S	Pump Access Screw
T	Hose - 25-ft.
U	Material Thickness Gauge
V	Cleaning Ball
W	Spare Hose Gaskets

# Preparation

## Pressure Relief Procedure

- 1 Turn Main Power Switch (A) OFF.

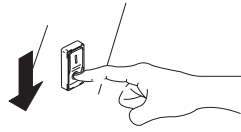

ti4292a

- 2 Turn fluid flow regulator (K) all the way down to reduce pressure.

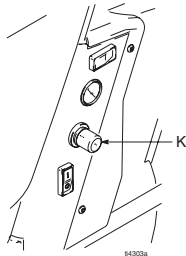

ti4303a

- 3 Open gun air valve (aa).

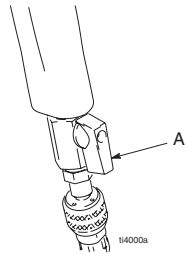

ti4000a

- 4 Trigger gun, spraying material back into hopper (C).

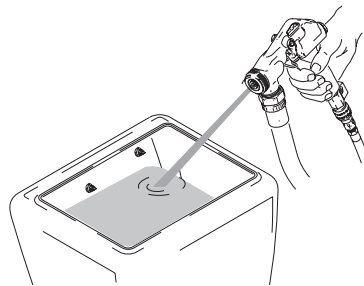

ti4294a

## Grounding and Electric Requirements

The sprayer must be grounded. Grounding reduces the risk of electrical shock by providing an escape wire for the electrical current.

**⚠ WARNING**



Read warnings, page 4.

- The sprayer cord includes a grounding wire with an appropriate grounding prong.

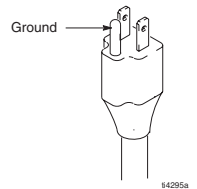

ti4295a

- The plug must be plugged into an outlet that is properly installed and grounded in accordance with all local codes and ordinances.

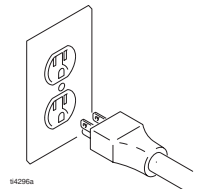

ti4296a

- Do not modify plug! If it will not fit in outlet, have grounded outlet installed by a qualified electrician.

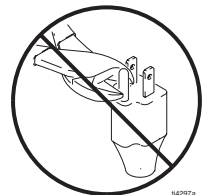

ti4297a

- Sprayer model electric requirements are provided on page 3.

### Extension Cords

- Only use an extension cord with an undamaged 3-prong plug.

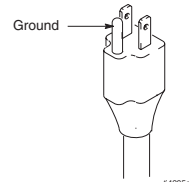

ti4295a

- For up to 100 ft (30.48 m) cord, use 3-wire, 12 AWG (2.5 mm<sup>2</sup>) minimum.



## Auxiliary Air Compressor

- Use Auxiliary Air Hookup Kit 287328 when additional atomization air is necessary.

<b>CAUTION</b>
----------------

Attaching auxiliary air to sprayer without using the Auxiliary Air Hookup Kit will damage sprayer.
--

## Generators

7500 W (7.5 KW) minimum.

### Tips for Using Generators

- Before running sprayer, make sure it is at room temperature. This will reduce startup current.
- Run generator at full throttle.

## Hose Lengths

- The system comes with a twin line hose set consisting of a 1 in. ID x 25 ft (25 mm x 7.6 m) material hose and a 3/8 in. ID air hose. Additional hose sections can be added. Total final length of hose used should not exceed 100 feet in length.

<b>CAUTION</b>
----------------

Sprayer air hose fitting can get hot! Allow sprayer to cool down 5 minutes before removing air hose.
--

# Removing and Replacing Hopper, Front and Back Covers

**Before performing any service on sprayer always:**

- Read all warnings, page 4.
- Read operating instructions manual, page 3.
- **Relieve Pressure**, page 8.
- Turn main power switch (A) OFF.
- Unplug sprayer from outlet.
- Remove air and material hoses.
- Clean sprayer. See Operation Manual 310624 or 310625.

## Hopper

### Removing Hopper

- 1 To remove hopper loosen fitting. Fittings are hand-tightened and should not require tools to loosen.

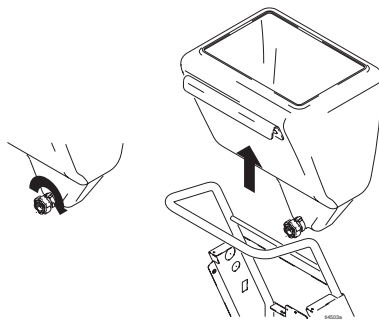

- 2 Lift hopper straight up, off frame.

### Replacing Hopper

- 1 To replace hopper, position drain over fitting as far as it will go, making sure identification label faces out.
- 2 Hand tighten fitting.

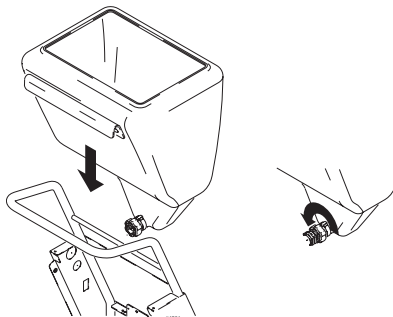

## Front Cover

### Removing Cover

- 1 Remove hopper.

- 2 Unscrew and remove knob (S).

- 3 Place your hand under front, bottom edge of cover. **(3a)** Lift cover up, **(3b)** then pull bottom toward you and out to remove cover.

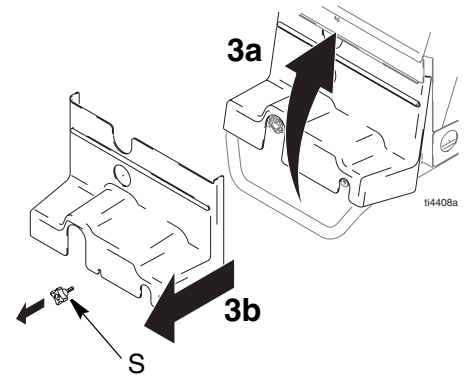

### Replacing Cover

- 1 Place your hand under front, bottom edge of cover. **(1a)** Position top edge of cover under top metal lip on sprayer frame. **(1b)** Then push up on cover so lower plastic edge of cover has room to clear front metal frame and slide cover into place. To position cover correctly, it will go in at an angle.

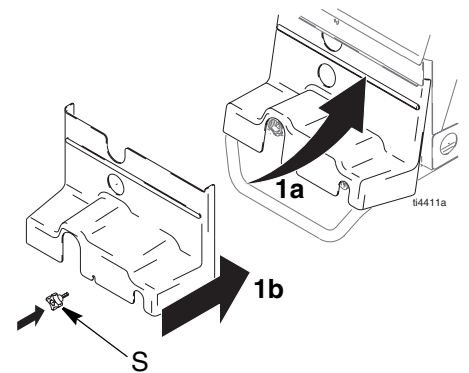

- 2 Replace knob (S). Hand tighten fitting.

- 3 Replace hopper.

## Back Cover

To access the motor and all other components, it is necessary to remove the hopper, front and back covers.

### Removing Cover

- 1 Completely remove 6 screws (2 on top and each side) from cover.

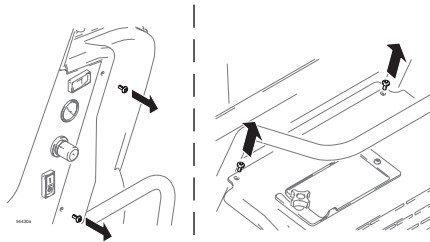

- 2 Lift cover up and then tilt it back and off sprayer frame.

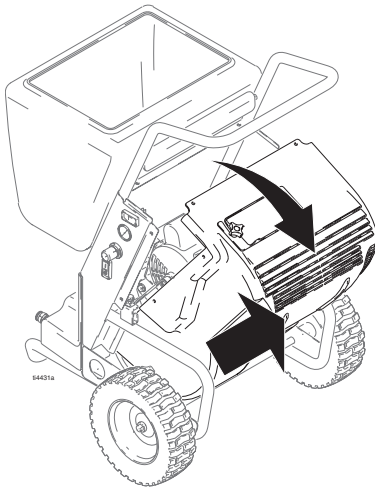

### Replacing Cover

- 1 To reposition cover on sprayer frame, tip the cover back, toward you and slide it down, into place in the base of the frame. Then push the top back into place. Align screw holes in side and top of cover with holes in frame.

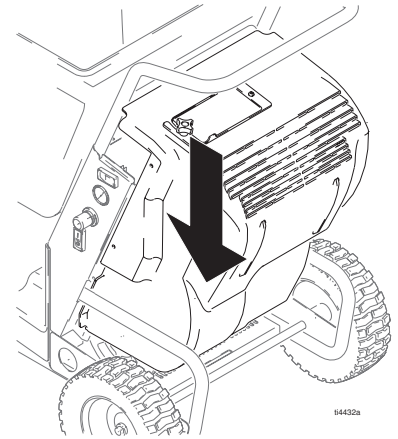

- 2 Replace and tighten screws.

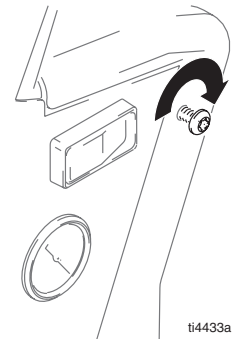

# RotoFlex™ HD Pump

Use RotoFlex HD Pump Replacement Kit 287314.



## IMPORTANT

- After replacing RotoFlex HD Pump hose, always follow Hose Break-In Procedure, page 14, before operating sprayer.

## Disassembly

First read and follow instructions in the **Before performing any service on sprayer** section, page 10.

Then remove hopper and front cover, page 10.

- 1 Loosen and remove hose extension.



- 2 Loosen and remove knob.

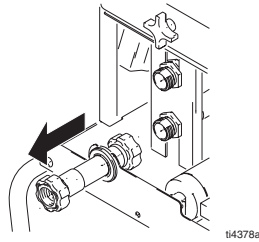

- 3 Slide RotoFlex HD hose off rollers.

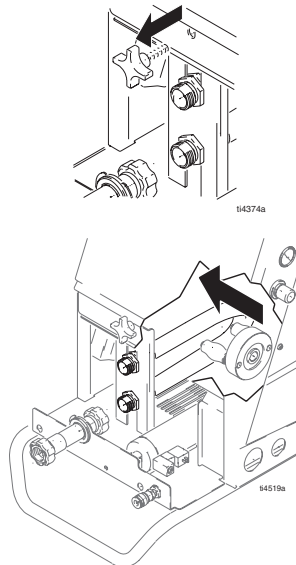

- 4 Rotate pump assembly sideways. Pull entire assembly out of front of sprayer frame.

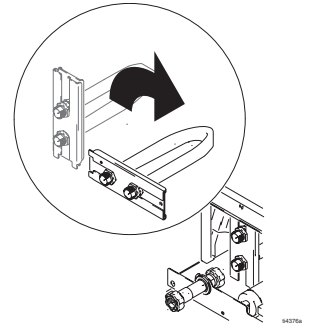

- 5 Separate the inner and outer hose brackets.

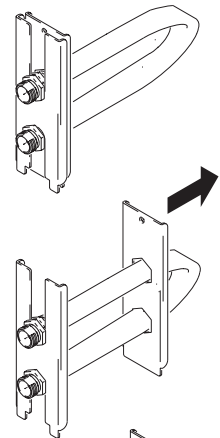

- 6 Slide hose ends out of slots in outer hose bracket.

- Slide out of short slot first.

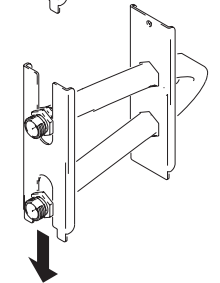

- 7 Pull hose out of inner hose bracket.

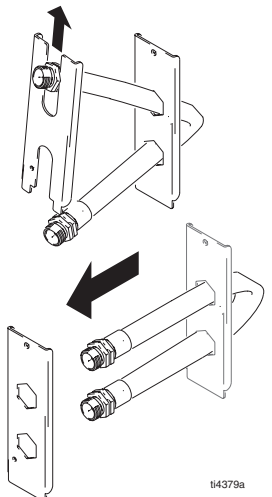

- 8 Discard pump hose.

## Reassembly

- 1 Bend and kink new pump hose from kit in the middle as shown, making sure dots on hose fittings face each other.

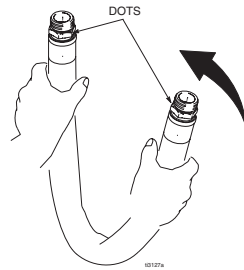

- 2 Insert hose ends through holes in inner hose bracket, keeping dots on fittings facing each other and kinked portion of hose horizontal to the underside of bracket.

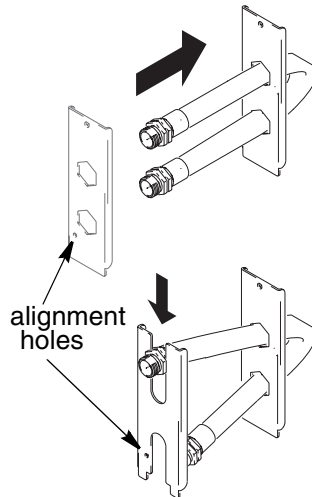

- 3 Slide hose ends into outer hose bracket, making sure dots on fittings face each other and alignment holes are together.

- Slide into long slot first.

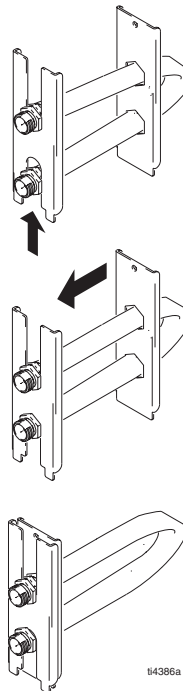

- 4 Slide plates together, inserting inner plate in outer plate, matching alignment holes.

- 5 Replace bracket assembly in housing making sure the mounting screw hole, located in the top center of the inner plate, faces up.

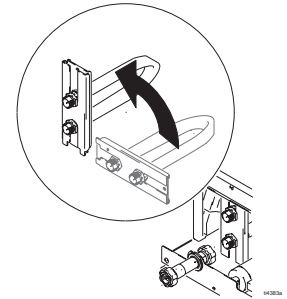

- 6 Slide pump hose around rollers. Make sure the rollers are horizontally parallel to each other.

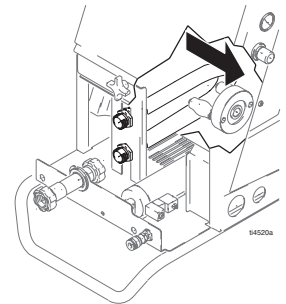

- 7 Slide feet on the bottom of hose bracket, into the slot on the bottom of sprayer.

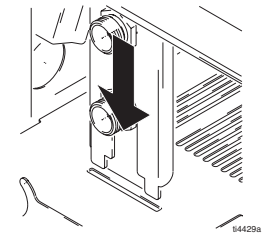

- 8 Replace knob. Hand tighten.

- 9 Reattach hose extension.

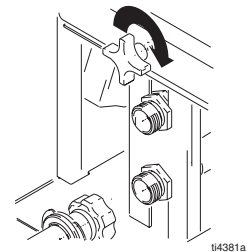

- 10 Replace front cover and hopper. See Removing and Replacing Hopper, Front and Back Cover, page 10.

## Hose Break-In Procedure

1 Make sure fluid flow regulator (K) is turned all the way down.

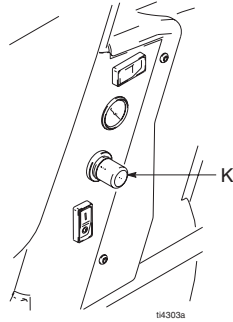

2 Pour approximately 1 gallon **hot** water in sprayer hopper to lubricate the pump.

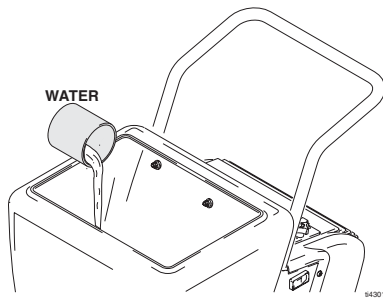

3 Turn power switch (A) on.

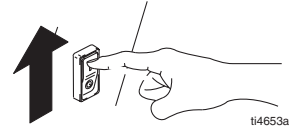

4 Hold in prime switch (P).

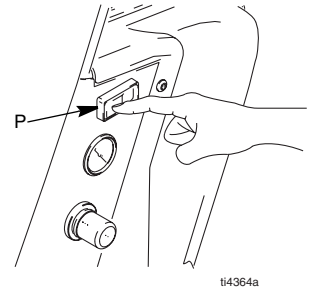

5 Turn fluid flow regulator (K) up to full pressure.

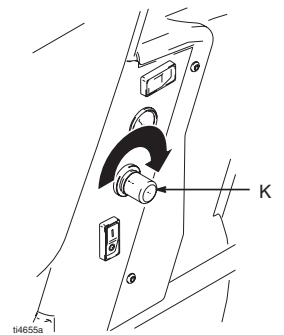

6 Run sprayer dry for 1 to 1-1/2 minutes.

# Compressor and Motor Repair

For 120 V sprayer use Compressor and Motor Replacement Kit, 287315.

For 230 V sprayer use Compressor and Motor Replacement Kit, 287344.

Kits include motor/compressor and mounting hardware.

## Disassembly

First read and follow instructions in the **Before performing any service on sprayer** section, page 10.

Then remove hopper, front and back covers, page 10.

Remove hose extension and RotoFlex HD Pump assembly from frame, page 12.

- 1 Remove two screws and access cover on the left side of the motor.

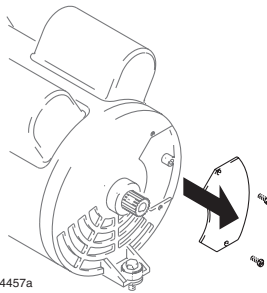

- 2 Remove ground nut and disconnect green ground wire.

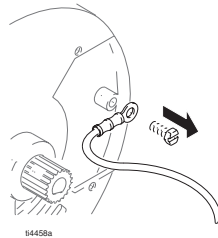

- 3 Disconnect black and white wires to motor.

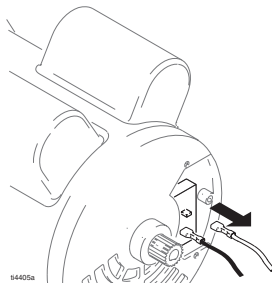

- 4 Loosen 4 bolts (2 each side) to loosen tension on belt.

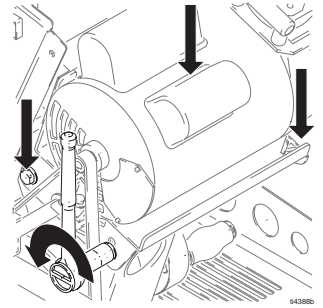

- 5 Slide belt off motor pulley.

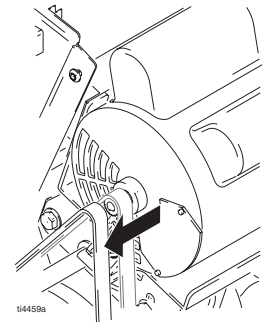

- 6 Disconnect air line from compressor to cooler and remove.

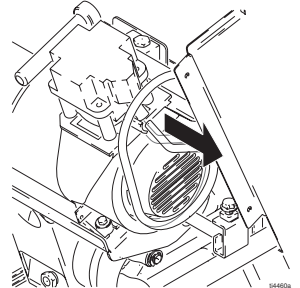

- 7 Remove 3 screws on right side of cover and remove cover.

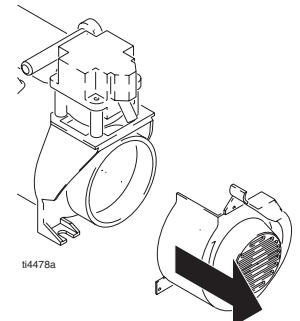
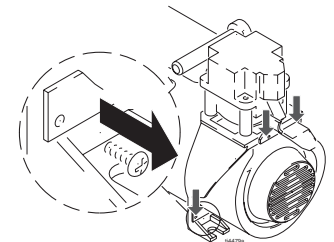

- 8 Loosen 2 shoulder bolts about 2-3 turns. Do not remove them.

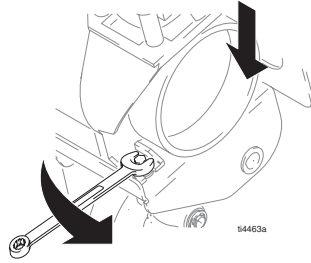

- 9 Remove single shoulder bolt on other side of motor completely.

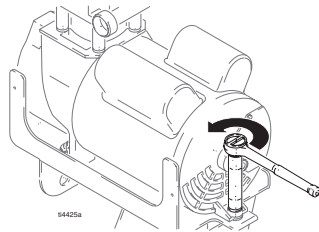

- 10 Slide out motor assembly.

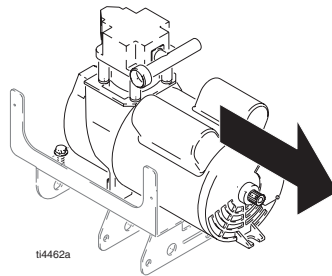

- 11 Completely remove old shoulder bolts and rubber mounts.

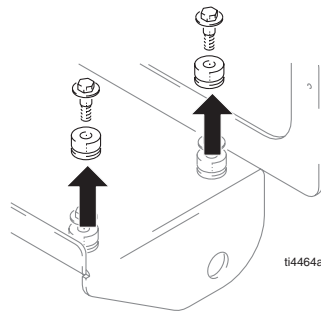

- 12 Thoroughly clean inside housing to remove dust and debris.

## Reassembly

- 1 Using two new shoulder bolts and rubber mounts included in your kit, insert bolts into openings until they start to snug up on rubber mounts.

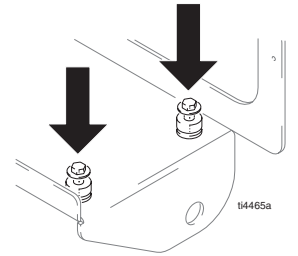

- 2 Slide new motor into sprayer frame, aligning motor frame opening under bolts. Tighten bolts.

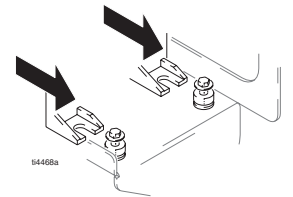

- 3 Replace shoulder bolt on left side with new bolt from your kit. Tighten bolt.

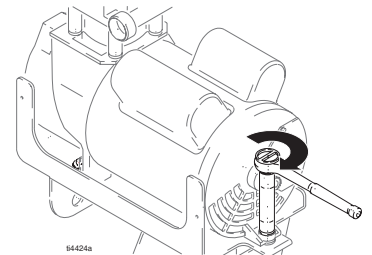

- 4 Replace end cover. Replace and tighten 3 screws.

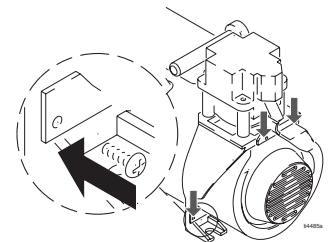
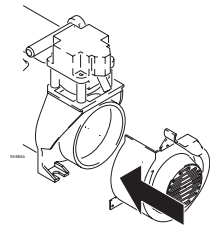

- 5 Reattach air line to cooler and compressor. Tighten fitting.

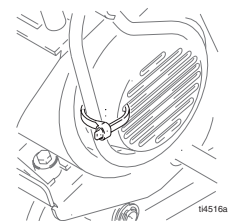



6 Slide belt over pulleys and set tension. See Replacing Belt, page 20.

7 Reattach black and white wires to motor.



Wires are not polarity sensitive.

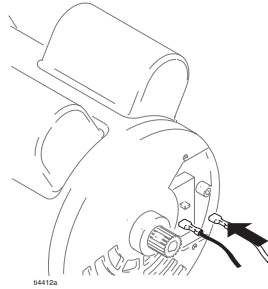

8 Replace reattach green ground wire and grounding nut.

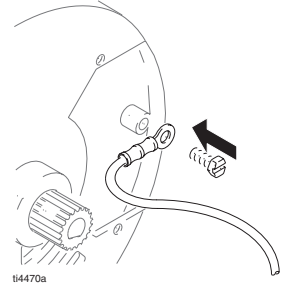

9 Replace cover plate and screws.

10 Replace RotoFlex HD Pump and hose extension, page 13.

11 Replace front and back covers and hopper. See Removing and Replacing Hopper, Front and Back Cover, page 10.

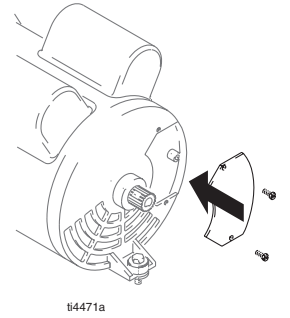

# Compressor Rebuild Kit

To replace piston, seals and sleeve.

For 120 V sprayer use Compressor Rebuild Kit 287330.

For 230 V sprayer use Compressor Rebuild Kit 287331.

## Disassembly

First read and follow instructions in the **Before performing any service on sprayer** section, page 10.

Then remove back cover, page 10.

- 1 Disconnect air line to motor.

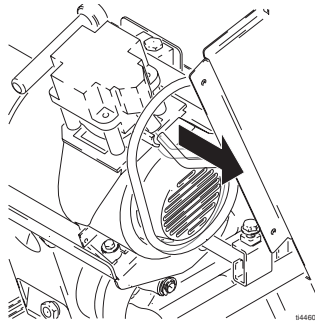

- 2 Remove 3 screws in side of motor cover. Remove cover.

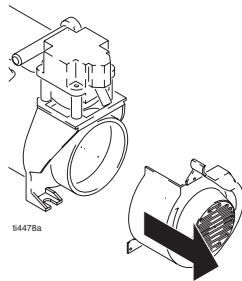
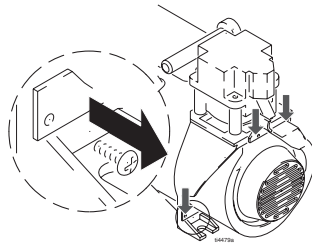

- 3 Remove fan bolt from center of fan and remove fan from housing.

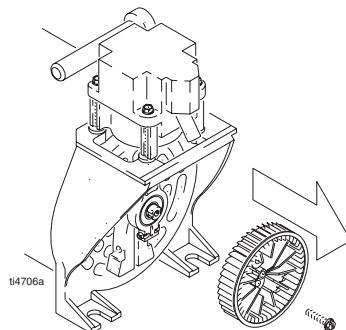

- 4 Remove 3/8 in. bolt holding piston to motor shaft.

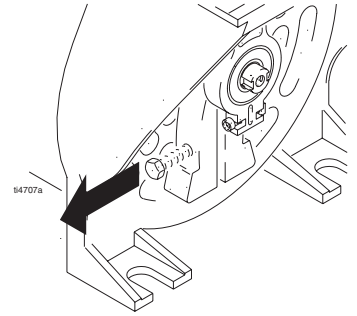

- 5 Loosen 4 bolts on top of motor housing.

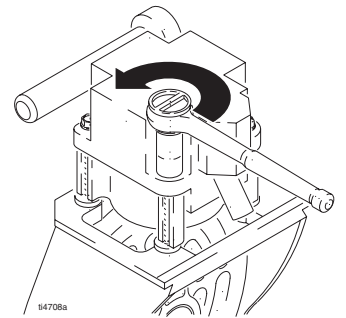

- 6 Remove bolts and housing from motor.

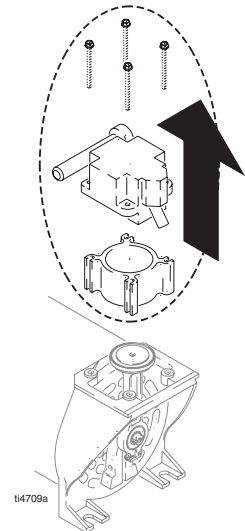

- 7 Remove piston rod from motor.

- 8 Using parts in kit replace piston, seals and sleeve.

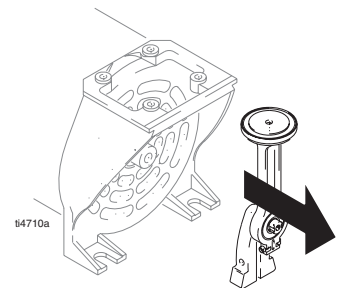

## Reassembly

- 1 Insert new piston rod from kit in motor housing.

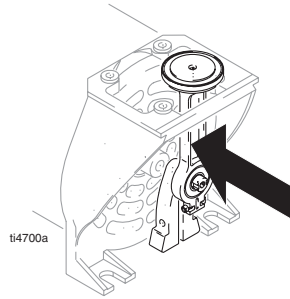

- 2 Replace and tighten piston bolt.

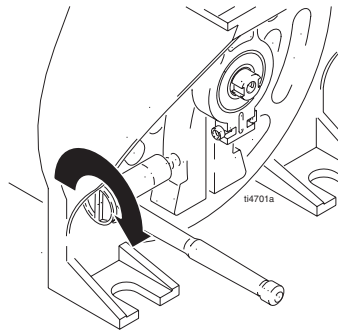

- 3 Replace top motor hosing and 4 bolts.

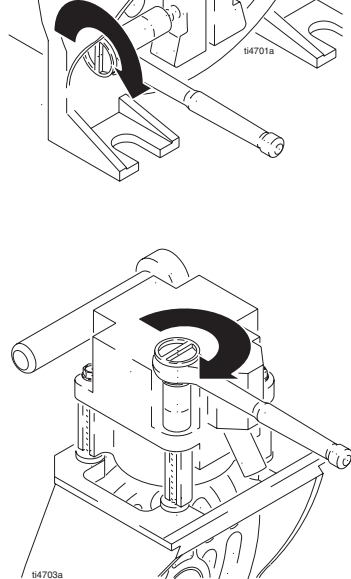

- 4 Tighten bolts.

- 5 Replace motor fan and center fan bolt.

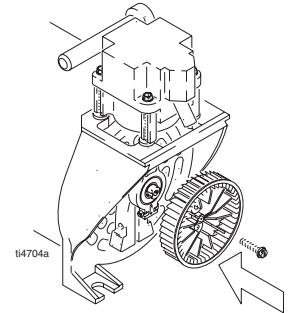

- 6 Tighten bolt.

- 7 Replace motor cover and screws.

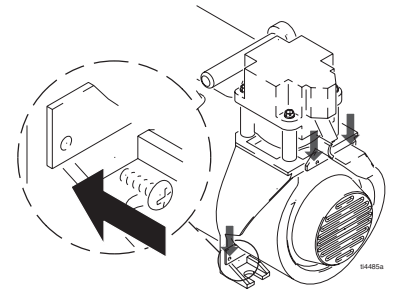

- 8 Reconnect air line from motor to cooler.

- 9 Replace back cover. See Removing and Replacing Hopper, Front and Back Cover, page 10.

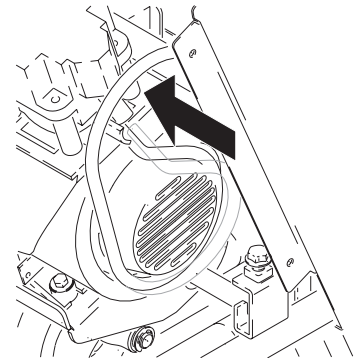

# Removing and Replacing Belt

Use Belt Replacement Kits 118845.

First read and follow instructions in the **Before performing any service on sprayer** section, page 10.

Then remove hopper, front and back covers, page 10.

Remove hose extension and RotoFlex HD Pump assembly from frame, page 12.

## Removing Belt

- 1 Loosen 4 bolts (2 each side) to loosen tension on belt.

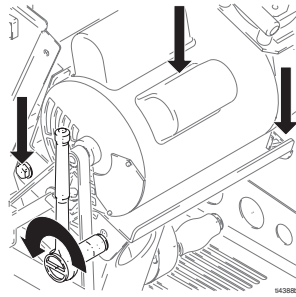

- 2 Loosen 2 bolts (1 each side) holding down support rod.

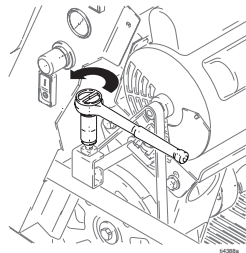

- 3 Using a screw driver for leverage, lift up on motor support rod on one side of motor and ease it out of the holding bracket far enough to remove old belt. Discard old belt.

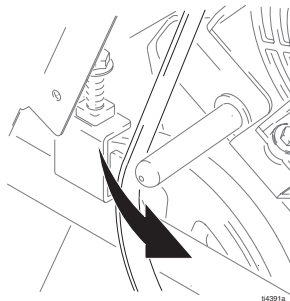

At the same time, slide in the new belt.

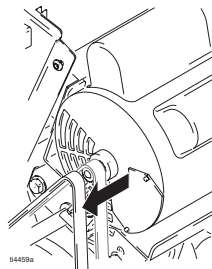

## Replacing Belt

- 1 Using new belt from Kit, position new belt around pulleys making sure the teeth in the belt are properly engaged with teeth on pulleys.

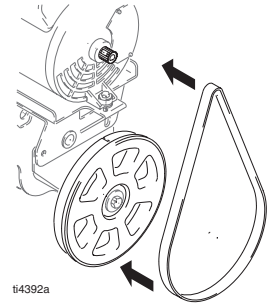

- 2 Replace support rod. Tighten 2 bolts (1 each side) to secure supporting rod.

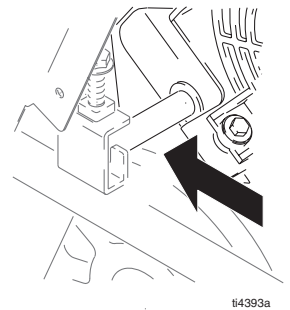

- 3 Insert crow bar under assembly as shown and raise motor assembly until desired belt tension is achieved.

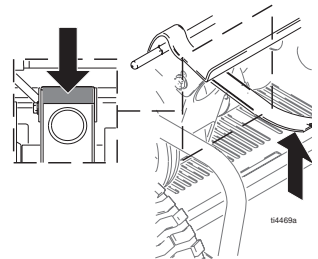

- 4 While holding motor assembly in place with crow bar. Spin pulley to assure proper belt engagement. Adjust motor assembly position as necessary.

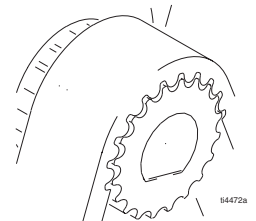



A correctly tensioned belt will feel very tight. To measure correct tension, apply 4-5 lbs pressure at belt midpoint with thumb. Belt should have approximately 1/8 in. (3.175 mm) deflection.

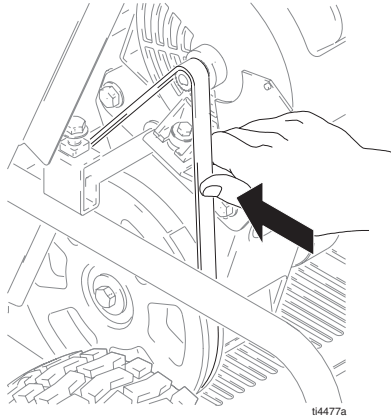

A loose belt will not last long. If in doubt, tighten more.

5 Tighten all 4 bolts.

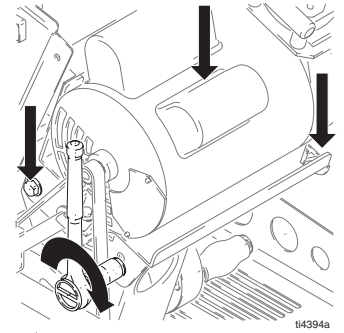

6 Turn belt one more time with your hand to make sure teeth are properly engaged and tension is correct.

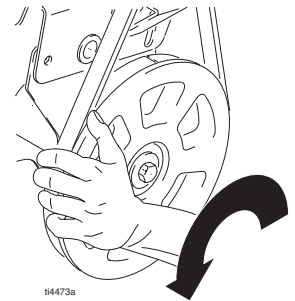

7 Replace RotoFlex HD Pump and hose extension, page 13.

8 Replace back and front covers and hopper. See Removing and Replacing Hopper, Front and Back Cover, page 10.

# Roller Replacement

Use Roller Replacement Kit 287321.

Kit includes 2 rollers, 4 nylon washer, and 2 retaining rings.

## Disassembly

First read and follow instructions in the **Before performing any service on sprayer** section, page 10.

Then remove hopper, front and back covers, page 10.

Remove hose extension and RotoFlex HD Pump assembly from frame, page 12.

- 1 Remove snap ring.



- 2 Remove roller assembly from rotor pins (a).

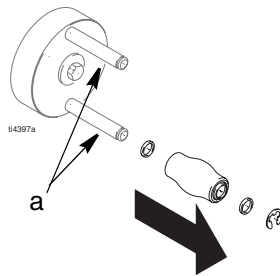

- 3 Clean rotor pins (a) and check for damage. If pins are worn or damaged, replace rotor assembly, (Rotor Assembly Replacement, page 23).

## Reassembly

- 1 Replace roller assembly.

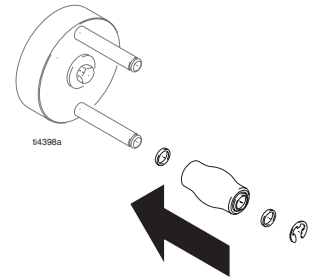

- 2 Reinstall snap ring.

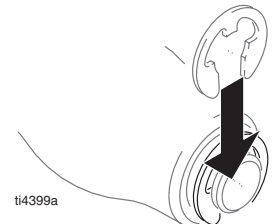

- 3 Replace RotoFlex HD Pump and hose extension, page 13.

- 4 Replace back and front covers and hopper. See Removing and Replacing Hopper, Front and Back Cover, page 10.

# Rotor Assembly Replacement

Use Pump Assembly Replacement Kit 287255.

## Disassembly

First read and follow instructions in the **Before performing any service on sprayer** section, page 10.

Then remove hopper, front and back covers, page 10.

Remove hose extension and RotoFlex HD Pump assembly from frame, page 12.

- 1 To prevent rotor assembly from moving, insert a long screw driver or pry bar in the pulley.

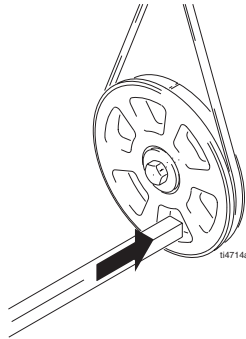

- 2 Remove large bolt and washer in center of rotor assembly.

- 3 Pull rotor assembly off shaft.

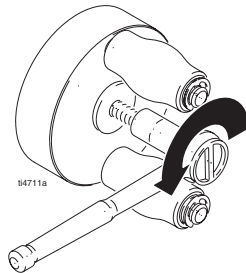

## Reassembly

- 1 Put new rotor assembly from kit on shaft.

- 2 Insert a wrench in the pulley to prevent it from moving..

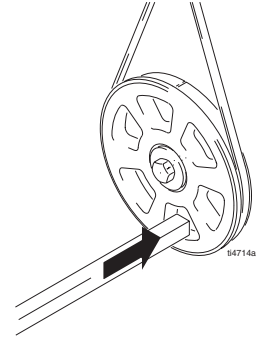

- 3 Replace bolt. Torque to 40 ft. lbs.

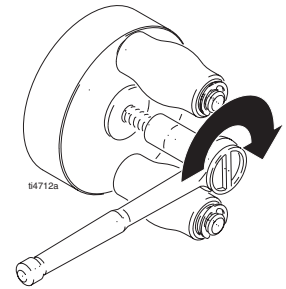

- 4 Replace RotoFlex HD Pump and hose extension, page 13.

- 5 Replace back and front covers and hopper. See Removing and Replacing Hopper, Front and Back Cover, page 10.

# Air Cylinder and Solenoid Valve

Use Cylinder Replacement Kit, 287323.

For 120 V sprayer use Solenoid Replacement Kit 287324.

For 230V sprayer use Solenoid Replacement Kit 287351.

## Disassembly

First read and follow instructions in the **Before performing any service on sprayer** section, page 10.

Then remove hopper, front and back covers, page 10.

Remove hose extension and RotoFlex HD Pump assembly from frame, page 12.

- 1 Remove hose from quick release fitting by using your fingers on one hand to push in on ring while at the same time, using the other hand, gently pull the hose out of the fitting.

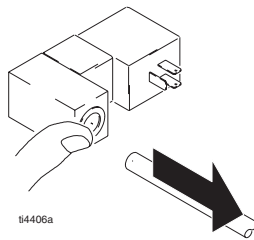

- 2 Remove electric wire terminal connections.

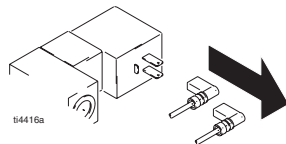

- 3 Remove cotter key located on the end of the cylinder pin, by using a pliers to straighten the ends and pull it out of the hole.

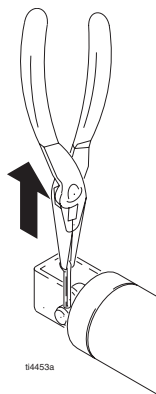

- 4 Gently push cylinder forward, relieving tension on pin. Pull out pin.

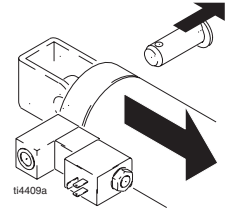

-  If replacing solenoid valve only, it can be done at this time.
- a Using an adjustable wrench, rotate entire solenoid valve assembly counter clockwise from cylinder.
  - b Replace solenoid valve and continue with step 4 of reassembly.

- 5 Lift cylinder up and pull it back.

- 6 Remove dampening grommet.

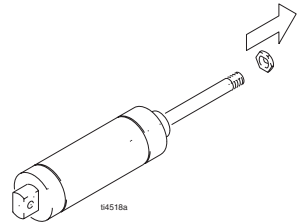

- 7 Using a 15/16 in. wrench, loosen nut, located inside sprayer frame at the end of the air cylinder.

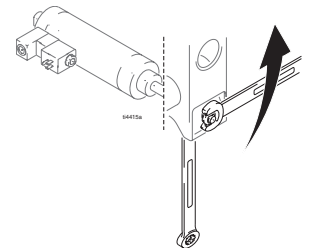

- 8 Using a 15/16 in. wrench, loosen nut on the other side of the sprayer frame.

- 9 Pull cylinder out of sprayer frame.

If replacing cylinder only, remove solenoid valve (see a and b above) and reinstall on new cylinder.

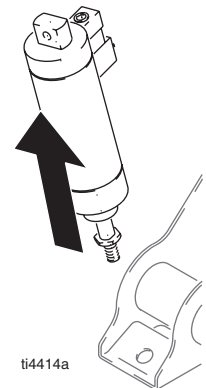



## Reassembly

1 Insert crowned backing nut on shaft of cylinder.

2 Using new cylinder from kit, position cylinder in sprayer frame, inserting end of cylinder through pump bracket mounting hole.

3 Install locking nut flush to end of shaft.

4 Install dampening grommet.

5 Align hole in end of air cylinder and replace pin.

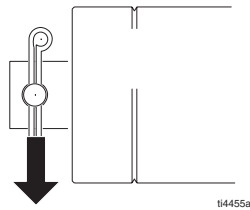
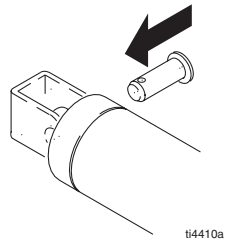
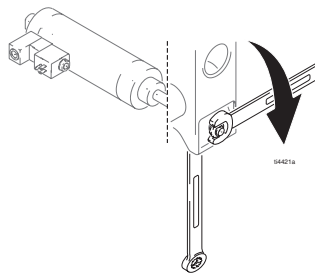

6 Replace cotter pin through hole in pin, bending ends to secure.

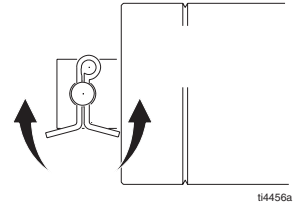

7 Reattach electric wire terminals. Terminals are not polarity sensitive and can be connected to either post.

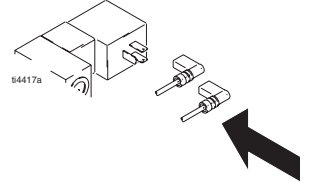

8 Gently push hose in quick release fitting.

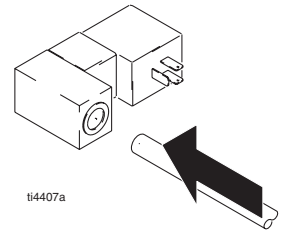

9 Replace RotoFlex HD Pump and hose extension, page 13.

10 Replace front cover and hopper. See Removing and Replacing Hopper, Front and Back Cover, page 10.

# Relief Valve and Flow Sensor Manifold

For 120 V sprayer use Relief Valve Replacement Kit 287325.

For 230 V sprayer use Relief Valve Replacement Kit 287350.

## Disassembly

First read and follow instructions in the **Before performing any service on sprayer** section, page 10.

Then remove hopper, front and back covers, page 10.

1 Remove air line to regulator.

2 Remove air line from cooler to manifold.

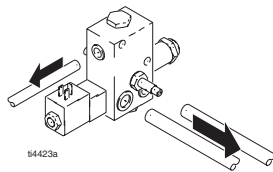

3 Disconnect wires to Relief Valve. Pay attention to their location to insure they are reattached correctly.

4 Remove 2 nuts securing Relief Valve to sprayer.

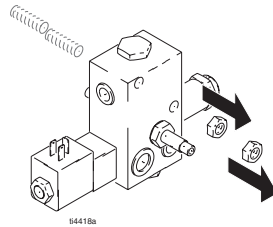

5 Remove Relief Valve from sprayer frame.

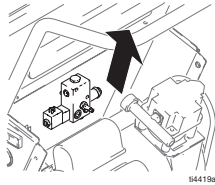

## Reassembly

1 Position new relief valve from Kit in back of sprayer.

2 Replace and tighten screws.

3 Reattach wires to Relief Valve.

4 Reattach air line from cooler to manifold.

5 Reattach air line to regulator. Replace RotoFlex HD Pump and hose extension, page 13.

6 Replace front cover and hopper. See Removing and Replacing Hopper, Front and Back Cover, page 10.

# Air Flow Sensor Replacement

For 120 V sprayer use Sensor Replacement Kit 287326.

For 230 V sprayer use Sensor Replacement Kit 287345.

 If you are just replacing the sensor, you do not have to remove the motor first.

## Disassembly

First read and follow instructions in the **Before performing any service on sprayer** section, page 10.

Then remove hopper, front and back covers, page 10.

Remove hose extension and RotoFlex HD Pump assembly from frame, page 12.

- 1 Disconnect all wire connections.

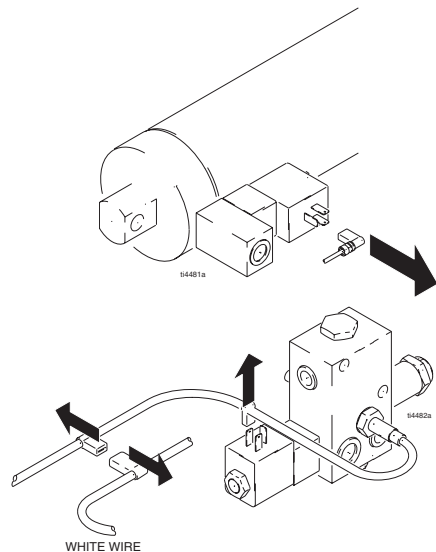

- 2 Rotate counter-clockwise to remove sensor from manifold.

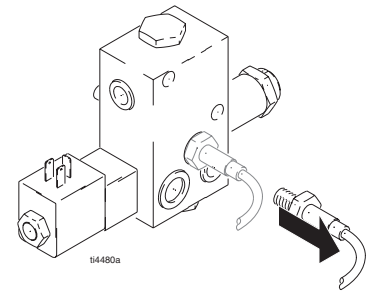

## Reassembly

- 1 Rotate new sensor from kit clockwise, all the way into opening in Relief Valve housing. Lightly tighten nut.

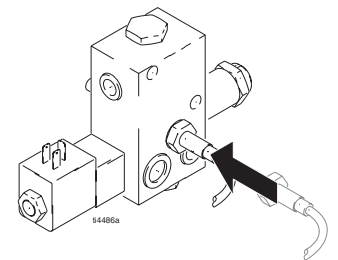

- 2 Reconnect all wires.

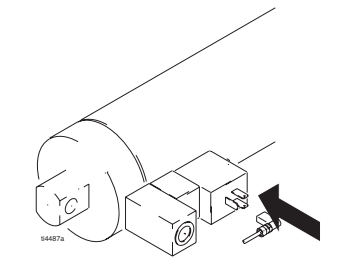

- 3 Replace RotoFlex HD Pump and hose extension, page 13.

- 4 Replace back and front covers and hopper. See Removing and Replacing Hopper, Front and Back Cover, page 10.

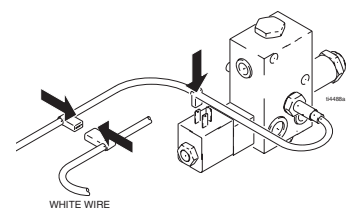

# Troubleshooting



## Pressure Relief, page 8

Problem	Cause	Solution
Sprayer won't run or stops intermittently	Power switch not on	Turn switch on.
	No power at wall outlet	Check outlet by plugging in another appliance. If appliance does not work, try another outlet.
	Wrong size generator	Use a 7500 watt or larger generator. Refer to Generator Requirements, page 9.
	Temperature too cold	Allow unit to warm up.
	Too many items on same circuit	Unplug other items from circuit.
	Internal thermal switch tripped	Self-resetting. Allow unit to cool down 15 minutes and restart. Usually occurs when wrong size extension cord is used.
	Extension cord too long or wrong gauge	Use a 12 gage extension cord or remove extension cord. Refer to Grounding and Electric Requirements, page 8.
	Breaker tripped	Reset breaker.
Pump won't pump material or low output	Air lock	Open air valve on gun.
	Mix too thick	Add water to thin material. Use Material Thickness Gauge.
	Loose fittings	Check and retighten all fittings.
	Plugged gun	<b>Relieve Pressure</b> , page 8. Remove gun from hose. Clean gun.
	RotoFlex HD Pump worn out	Replace hose.
	Pump cold or material frozen in pump	Move pump to warm room and allow it to warm up or run hot water through sprayer.
	Sensor is bad	Replace, page 27
	Check air system for leaks	Remove shroud and examine for air leaks
	Loose wire	Remove shroud and examine wiring
	No air pressure	Rebuild compressor
Soft start won't work/pump, always loaded	Sensor is bad	Change sensor, page 27
	Air leak due to bad seal keeps valve open	Replace seal
	Normal soft start system delay	Release trigger for 10-15 seconds. Retry.
	Switch is not operating properly	Replace switch
	Damaged solenoid valve on cylinder	Check gun supply, hose and sprayer for leaks
	Air leak	

<b>Problem</b>	<b>Cause</b>	<b>Solution</b>
Material runs out of bottom of sprayer	RotoFlex HD Pump worn out	Replace hose.
	Loose fittings	Check and retighten all fittings.
No air from compressor	Gun air valve closed	Open gun air valve.
	Gun needle plugged	Clean needle and retry.
	Lines not connected	Check all quick disconnect connections to gun and hoses.
	Damaged hose	Replace hose.
	Worn compressor	Service compressor. Contact a qualified Graco Service Center.
Speed of application too slow	Material too thick	Thin material.
	Nozzle too small	Change nozzles to a larger size. See Operation Manual, Recommended Nozzle Selection Chart, page 20.
Speed of application too slow (cont.)	Flow control set too low	Increase flow control setting
	Plugged or dirty gun	<b>Relieve Pressure</b> , page 8. Clean gun.
	Kinked hose	Unkink hose.
	Gun fluid flow adjustment set too low	Increase flow adjustment with flow adjustment nut.
Intermittent flow/sputtering or air in material	Hopper connection not tight	Check gasket. Tighten connection.
	Debris in system	Clean
Air quick disconnect does not stay connected.	Dirty or corroded fitting	Clean thoroughly. Soak in oil. Apply a few drops of light oil.
Gun will not shut off	Worn nozzle or needle.	<b>Relieve Pressure</b> , page 8. Replace worn parts.
	Debris in needle passage	<b>Relieve Pressure</b> , page 8. Clean.
Fluid leaking at Flow Adjustment Nut	Damaged seal.	<b>Relieve Pressure</b> , page 8. Replace seal.
Needle adjustment won't adjust	Dirty threads	Clean threads
	Nozzle not on gun	Put nozzle on gun
	Flow nut set to maximum adjustment	Turn flow nut adjustment the other way

# Air Diagram

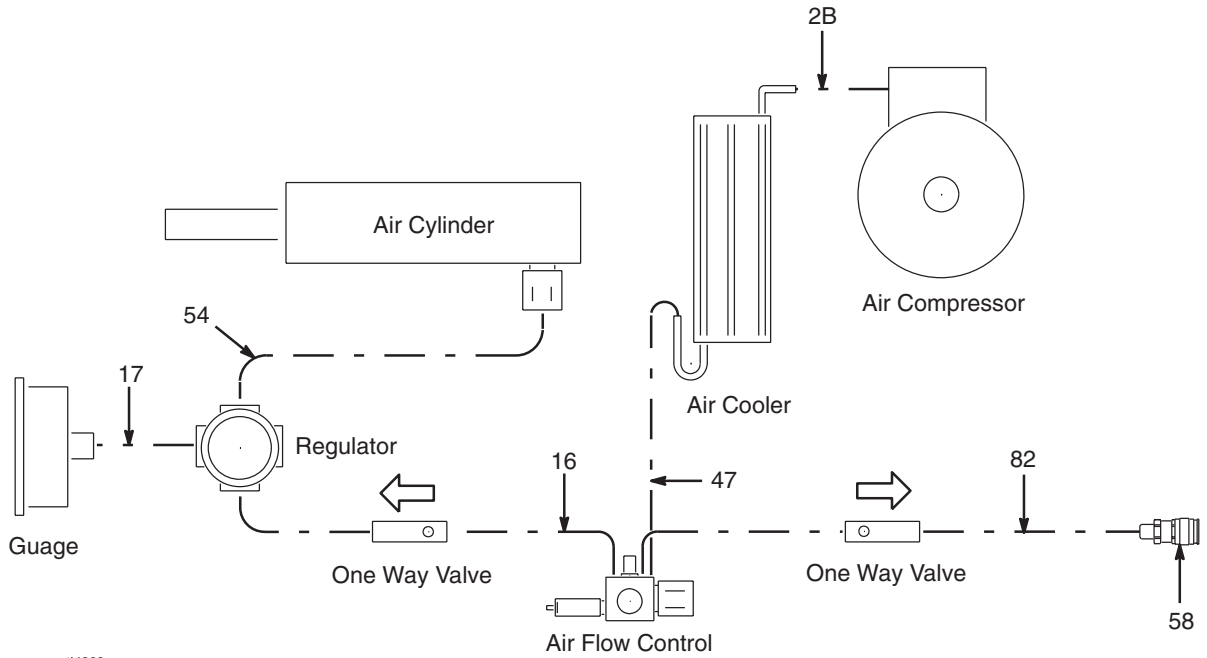

# Wiring Diagram

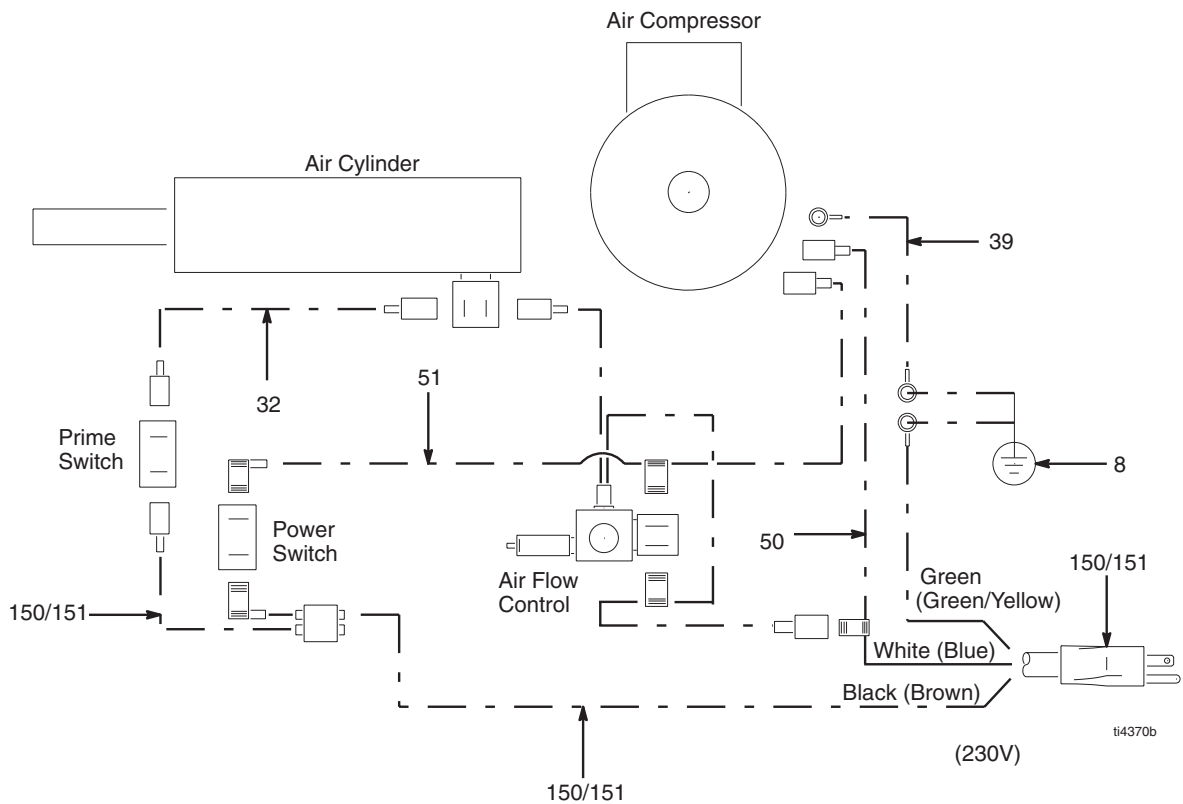

# Parts

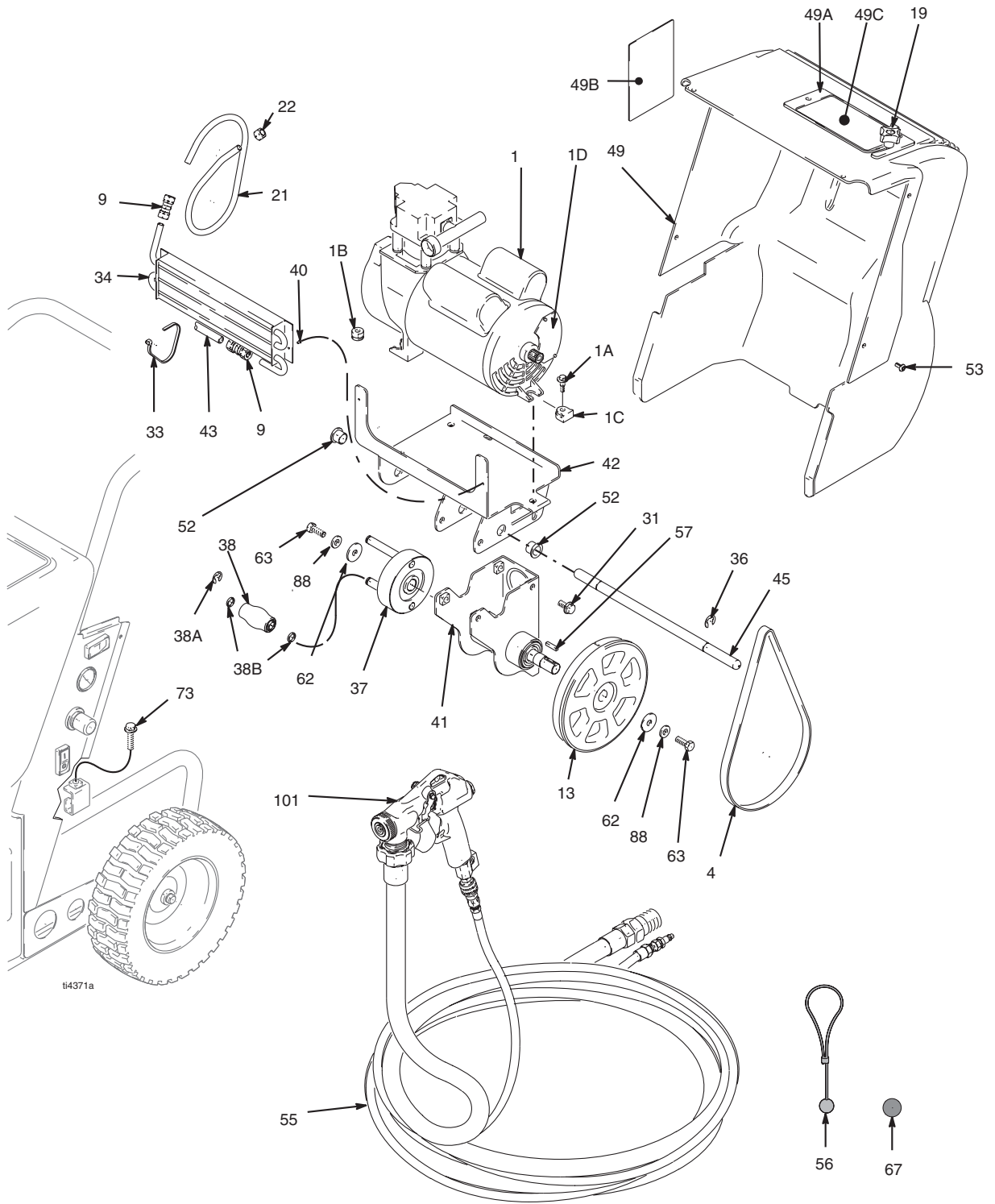

# Parts

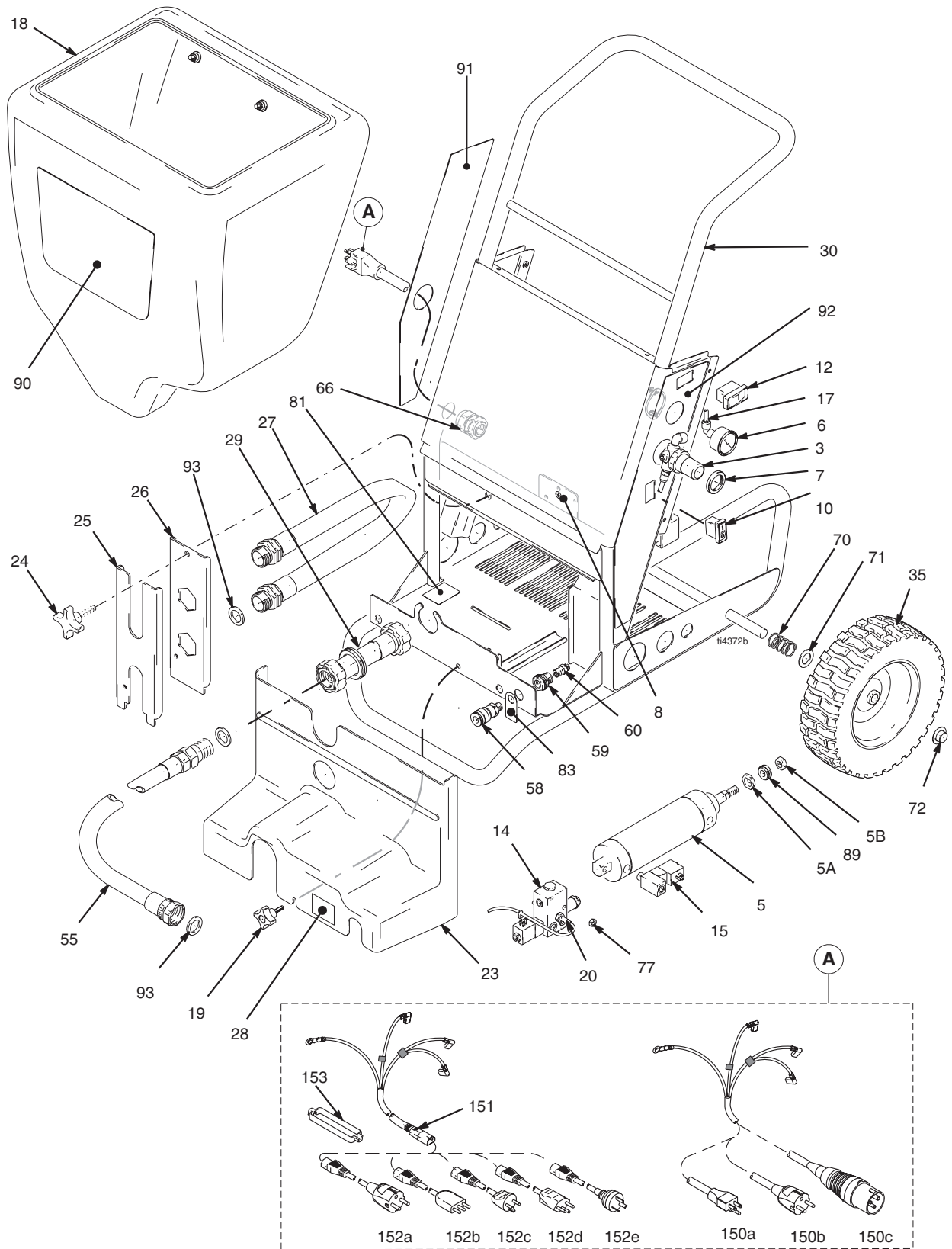



# Parts List

Item No.	Part No.	Description	Qty	Item No.	Part No.	Description	Qty
1	287315	KIT, compressor replacement (includes 1A and 1B-1D), 120V sprayers	1	34	15B815	COOLER	1
	287330	KIT, compressor rebuild, 120V sprayers		35	116478	WHEEL, pneumatic	2
	287344	KIT, compressor replacement (includes 1A, and 1B-1D), 230V sprayers		36	101242	RING, retaining, ext.	2
	287331	KIT, compressor rebuild, 230V sprayers		37	287255	ROTOR, pump, assbly (includes 38, 38A, 38B)	1
1A	119872	SCREW, shoulder	3	38	287321	KIT, roller replacement (includes 38A, 38B and two rollers)	2
1B	118886	GROMMET, isolator	2	38A	113983	RING, retaining, ext	2
1C	118889	GROMMET, isolator	1	38B	117726	WASHER, nylon	4
1D	119381	COVER, terminal	1	39	15D628	CONDUCTOR, ground	1
3	118844	REGULATOR, air, 1/8 in. NPT	1	40	103785	RIVET	2
4	118845	BELT	1	41	287327	KIT, repair, shaft, bracket, pump assbly.	1
5	287323	KIT, cylinder, replacement, (includes 5A, 5B, 89)	1	42	287256	BRACKET, compressor	1
5A	15D576	SPACER, crowned	1	43	118869	TUBE	1
5B	118871	NUT, lock, 1/2-20	1	45	15D610	SHAFT, motor, mount	1
6	117720	GAUGE, pressure	1	49	287346	SHIELD, rear, assbly (includes 19, 49A, 49B, 49C)	1
7	115244	NUT, regulator	1	49A	15D561	COVER, tool tray	1
8▲	186620	LABEL, ground, symbol	1	49B▲	15D939	LABEL, warning, English, French, Spanish	
9	117728	FITTING, compression, union	2		287336	KIT, label, warning, all languages except those included in 15D939	
10	117693	SWITCH, power	1	49C▲	15D940	LABEL, identification	
12	119064	SWITCH, power	1	51	15D634	WIRE, jumper	1
13	15D156	PULLEY, rotor	1	52	116937	BEARING, flanged, bronze	2
14	15D599	VALVE, assembly, 120V (includes sensor) sprayer	1	53	117630	SCREW, torx, tri lob	8
	287350	VALVE, assembly, 230V (includes sensor) sprayer		54	116666	TUBE, air	1
15	15D560	VALVE, cylinder, 120V sprayer	1	55	287304	HOSE SET, twin line, 1 in. x 25-ft	1
	287351	VALVE, cylinder, 230V sprayer	1	56	15C090	GAUGE, thickness, fluid	1
16	118888	HOSE, air (includes 1/4 in. tubing and one-way valve)	1	57	183401	KEY, parallel	2
17	15C968	TUBE, air	1	58	116720	COUPLER, air, quick disconnect	1
18	287347	HOPPER, texture (includes bracket)	1	59	104641	FITTING, bulkhead	1
19	15D862	NUT, hand	1	60	116658	FITTING, tube, male, 1/4 NPT	1
20	287326	KIT, sensor only, 120V	1	62	108851	WASHER, plain	2
	287345	KIT, sensor only, 230V		63	106276	SCREW, cap, hex head	2
21	118876	TUBE, air, aluminum	1	66	116171	BUSHING, strain relief	1
22	117637	NUT, compression	1	67	113397	BALL, sponge, 30 mm	2
23	287348	SHIELD, front (includes 28)	1	70	116411	SPRING, compression	2
24	108471	KNOB, pronged	1	71	116477	WASHER, flat, nylon	2
25	15D589	BRACKET, hose, outer	1	72	116342	CAP, end	2
26	15D588	BRACKET, hose, inner	1	73	112785	SCREW, flanged, hex head	2
27	287314	KIT, RotoFlex HD Pump	1	74	115498	SCREW, mach, slot, hex, wash hd	1
28▲	189286	LABEL, warning	1	77	102040	NUT, lock, hex	2
29	118885	HOSE, coupled (includes grommet)	1	81▲	198492	LABEL, warning	2
30	287254	FRAME, texture, blue	1	82	118887	HOSE, air (includes 1/4 in. tubing and one-way valve)	1
31	112395	SCREW, cap	4	83▲	15D089	LABEL, warning, hot surface	1
32	15D633	WIRE, jumper	1	88	118866	WASHER, flat	1
33	103473	STRAP, tie, wire	2	89	801012	GROMMET	1
				90▲	15D951	LABEL, identification	1
				91▲	15D953	LABEL, identification	1
				92▲	15D952	LABEL, identification	1
				93	118872	GASKET	4
				101	248091	GUN, non-bleeder	1

Item				Item			
No.	Part No.	Description	Qty	No.	Part No.	Description	Qty
150		CORD, power		152c	242002	Italy	1
150a	15D630	Americas/Canada, 120V, 60 Hz	1	152d	242003	Denmark	1
150b	15E056	Europe/Asia, 230V, 50 Hz (hardwired, rubber cord)	1	152d	242004	Switzerland	1
150c	15E061	United Kingdom, 110V, 60, Hz	1	152e	242005	Australia/China	1
151	15D902	CORD, power, Europe/Australia/China, 230V, 50 Hz (requires cordset adapter, 152, following)	1	153	195551	RETAINER, (for 15D902)	1
152		ADAPTER, cordset, (for 15D902),		▲ Replacement Danger and Warning labels, tags and cards are available at no cost.			
152a	242001	Europe	1				

## Technical Data

Maximum working fluid pressure	100 psi (6.9 bar)
Maximum working air pressure	45 psi (3.1 bar)
Material pressure operating range	0-100 psi (0 to 6.9 bar)
Compressor	
Type	Oilless
Air delivery	6.5 CFM @ 40 psi (184.1 lpm @ 2.8 bar)
Motor	
	120V, 60 Hz 15A
	230V, 50 Hz 10A
Hopper capacity	15 US gallons (57 liters)
Maximum delivery with texture material	2.0 gpm (7.57 lpm)
Dimensions	
Length	27 in. (685.8 mm) with handles
Width	26 in. (660.4 mm)
Height	40 in. (1016 mm)
Weight	
With hoses and gun	147 lb (66.68 kg)
Without hoses and gun	131 lb (59.47 kg)
Wetted parts	PVC, Buna-N, anodized aluminum, powder coat aluminum, brass, polyethylene, SST, UHMW
Sound data	
Sound pressure level*	85.8 db(A)
Sound power level#	100.1 db(A)
Generator (minimum size requirement)	7500W (7.5 kw)
Maximum external working air pressure (must use <i>External Air Hookup Kit 287328 ONLY</i> )	120 psi (8.3 bar)

\*Measured while spraying at 1 m.

#Measured per ISO-3744



# Warranty

Graco warrants all equipment referenced in this document which is manufactured by Graco and bearing its name to be free from defects in material and workmanship on the date of sale to the original purchaser for use. With the exception of any special, extended, or limited warranty published by Graco, Graco will, for a period of twelve months from the date of sale, repair or replace any part of the equipment determined by Graco to be defective. This warranty applies only when the equipment is installed, operated and maintained in accordance with Graco's written recommendations.

This warranty does not cover, and Graco shall not be liable for general wear and tear, or any malfunction, damage or wear caused by faulty installation, misapplication, abrasion, corrosion, inadequate or improper maintenance, negligence, accident, tampering, or substitution of non-Graco component parts. Nor shall Graco be liable for malfunction, damage or wear caused by the incompatibility of Graco equipment with structures, accessories, equipment or materials not supplied by Graco, or the improper design, manufacture, installation, operation or maintenance of structures, accessories, equipment or materials not supplied by Graco.

This warranty is conditioned upon the prepaid return of the equipment claimed to be defective to an authorized Graco distributor for verification of the claimed defect. If the claimed defect is verified, Graco will repair or replace free of charge any defective parts. The equipment will be returned to the original purchaser transportation prepaid. If inspection of the equipment does not disclose any defect in material or workmanship, repairs will be made at a reasonable charge, which charges may include the costs of parts, labor, and transportation.

**THIS WARRANTY IS EXCLUSIVE, AND IS IN LIEU OF ANY OTHER WARRANTIES, EXPRESS OR IMPLIED, INCLUDING BUT NOT LIMITED TO WARRANTY OF MERCHANTABILITY OR WARRANTY OF FITNESS FOR A PARTICULAR PURPOSE.**

Graco's sole obligation and buyer's sole remedy for any breach of warranty shall be as set forth above. The buyer agrees that no other remedy (including, but not limited to, incidental or consequential damages for lost profits, lost sales, injury to person or property, or any other incidental or consequential loss) shall be available. Any action for breach of warranty must be brought within two (2) years of the date of sale.

**GRACO MAKES NO WARRANTY, AND DISCLAIMS ALL IMPLIED WARRANTIES OF MERCHANTABILITY AND FITNESS FOR A PARTICULAR PURPOSE, IN CONNECTION WITH ACCESSORIES, EQUIPMENT, MATERIALS OR COMPONENTS SOLD BUT NOT MANUFACTURED BY GRACO.** These items sold, but not manufactured by Graco (such as electric motors, switches, hose, etc.), are subject to the warranty, if any, of their manufacturer. Graco will provide purchaser with reasonable assistance in making any claim for breach of these warranties.

In no event will Graco be liable for indirect, incidental, special or consequential damages resulting from Graco supplying equipment hereunder, or the furnishing, performance, or use of any products or other goods sold hereto, whether due to a breach of contract, breach of warranty, the negligence of Graco, or otherwise.

## **POUR LES CLIENTS DE GRACO PARLANT FRANCAIS**

Les parties reconnaissent avoir convenu que la rédaction du présent document ainsi que de tous les documents, avis et procédures judiciaires exécutés, donnés ou intentés à la suite de ou en rapport, directement ou indirectement, avec les procédures concernées, sera en anglais.

## **PARA LOS CLIENTES DE GRACO QUE HABLAN ESPAÑOL**

Las partes reconocen haber convenido que el presente documento, así como todos los documentos, notificaciones y procedimientos judiciales emprendidos, presentados o establecidos que tengan que ver con estas garantías directa o indirectamente, estarán redactados en inglés.

## **PER I CLIENTI GRACO ITALIANI**

Le controparti riconoscono di aver richiesto che il presente documento, e tutti gli altri documenti, avvisi e informazioni di natura legale sottoscritti, conferiti o istituiti direttamente o indirettamente, siano redatti in lingua inglese.

## **PARA CLIENTES PORTUGUESES DA GRACO**

As partes confirmam que solicitaram que o presente documento, assim como todos os demais documentos, notas e processos legais inseridos, atribuídos ou instituídos de acordo com o mesmo ou relacionados directa ou indirectamente com este documento, fossem redigidos em inglês.

## **VOOR GRACO-KLANTEN IN NEDERLAND**

De partijen zijn zich ervan bewust dat zij hebben geëist dat het onderhavige document, evenals alle documenten, berichtgevingen en wettelijke procedures die worden aangegaan, overhandigd of in gang gezet hetzij als gevolg van hetzij rechtstreeks hetzij indirect in relatie tot het onderhavige worden opgesteld in de Engelse taal.

## **ADDITIONAL WARRANTY COVERAGE**

Graco does provide extended warranty and wear warranty for products described in the "Graco Contractor Equipment Warranty Program".

*TO PLACE AN ORDER*, contact your Graco distributor, or call **1-800-690-2894** to identify the nearest distributor.

All written and visual data contained in this document reflects the latest product information available at the time of publication.  
Graco reserves the right to make changes at any time without notice.

MM 310645

**Graco Headquarters:** Minneapolis  
**International Offices:** Belgium, China, Japan, Korea  
GRACO INC. P.O. BOX 1441 MINNEAPOLIS, MN 55440-1441  
[www.graco.com](http://www.graco.com)  
PRINTED IN U.S.A. 310645E  
3/2004 Rev. 6/2005