

Air Actuated Fluid Valve

310655C

EN

5000 psi (34.5 MPa, 345 bar) Maximum Fluid Working Pressure

100 psi (0.7 MPa, 7 bar) Maximum Air Working Pressure

Model No. 287222, 287787

See wetted fluid parts on page 13 to determine fluid compatibility.



Important Safety Instructions

Read all warnings and instructions in this manual.
Save these instructions.

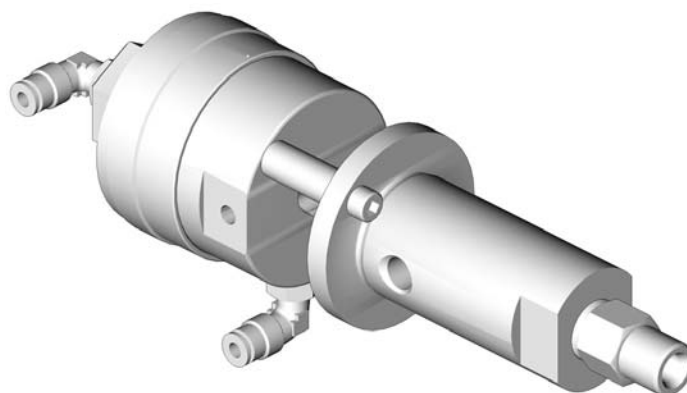

Contents

Manual Conventions	2	Troubleshooting	8
Warnings	3	Repair	9
Installation	5	Reassembly	11
Grounding	5	Parts	12
Operation	6	Technical Data	13
Settings and Adjustments	6	Dimensions	13
Pressure Relief Procedure	6	Graco Standard Warranty	14
Maintenance	7	Graco Information	14

Manual Conventions

 **WARNING**



WARNING: a potentially hazardous situation which, if not avoided, could result in death or serious injury.

CAUTION

CAUTION: a potentially hazardous situation which, if not avoided, may result in property damage or destruction of equipment.

Note

 Additional helpful information.

Warnings generally include a symbol indicating the hazard. Follow the instructions and read the indicated hazard section in the general warning pages for additional information.

Example:



 **WARNING**



Your system must be grounded. Read warnings, page 3, and follow instructions below.

Warnings

The following warnings include general safety information for this equipment. More specific warnings are included in the text where applicable.

 WARNING	
	<p>FIRE AND EXPLOSION HAZARD</p> <p>Flammable fumes, such as solvent and paint fumes, in work area can ignite or explode. To help prevent fire and explosion:</p> <ul style="list-style-type: none"> • Use equipment only in well ventilated area. • Eliminate all ignition sources; such as pilot lights, cigarettes, portable electric lamps, and plastic drop cloths (potential static arc). • Keep work area free of debris, including solvent, rags and gasoline. • Do not plug or unplug power cords, or turn power or light switches on or off when flammable fumes are present. • Ground equipment and conductive objects in work area. See Grounding instructions. • Use only grounded hoses. • Hold gun firmly to side of grounded pail when triggering into pail. • If there is static sparking or you feel a shock, stop operation immediately. Do not use equipment until you identify and correct the problem.
	<p>SKIN INJECTION HAZARD</p> <p>High-pressure fluid from dispense valve, hose leaks, or ruptured components will pierce skin. This may look like just a cut, but it is a serious injury that can result in amputation. Get immediate surgical treatment.</p> <ul style="list-style-type: none"> • Do not point dispense valve at anyone or at any part of the body. • Do not put your hand over the end of the dispense nozzle. • Do not stop or deflect leaks with your hand, body, glove, or rag. • Follow Pressure Relief Procedure in this manual, when you stop spraying and before cleaning, checking, or servicing equipment.

 **WARNING**

	<p>EQUIPMENT MISUSE HAZARD Misuse can cause death or serious injury.</p> <ul style="list-style-type: none"> • Do not exceed the maximum working pressure or temperature rating of the lowest rated system component. See Technical Data in all equipment manuals. • Use fluids and solvents that are compatible with equipment wetted parts. See Technical Data in all equipment manuals. Read fluid and solvent manufacturer’s warnings. • Check equipment daily. Repair or replace worn or damaged parts immediately. • Do not alter or modify equipment. • For professional use only. • Use equipment only for its intended purpose. Call your Graco distributor for information. • Route hoses and cables away from traffic areas, sharp edges, moving parts, and hot surfaces. • Do not use hoses to pull equipment. • Comply with all applicable safety regulations.
	<p>TOXIC FLUID OR FUMES HAZARD Toxic fluids or fumes can cause serious injury or death if splashed in the eyes or on skin, inhaled, or swallowed.</p> <ul style="list-style-type: none"> • Read MSDS’s to know the specific hazards of the fluids you are using. • Store hazardous fluid in approved containers, and dispose of it according to applicable guidelines.
	<p>PERSONAL PROTECTIVE EQUIPMENT You must wear appropriate protective equipment when operating, servicing, or when in the operating area of the equipment to help protect you from serious injury, including eye injury, inhalation of toxic fumes, burns, and hearing loss. This equipment includes but is not limited to:</p> <ul style="list-style-type: none"> • Protective eyewear • Clothing and respirator as recommended by the fluid and solvent manufacturer • Gloves

Installation

See **Dimensions** on page 13 for diagram.

Grounding

 **WARNING**





Your system must be grounded. Read warnings, pages 3-4.

To reduce the risk of static sparking, ground the pump and all other components used or located in the dispensing area. Check your local electrical code for detailed instructions for your area and type of equipment and be sure to ground all of these components.

- *Fluid hoses:* use only electrically conductive hoses with a maximum of 500 feet (150 m) combined hose length to ensure grounding continuity.
- *Dispensing valve:* obtain grounding through connection to a properly grounded fluid hose and pump.

Connect the Air Lines

Clean all lines and connections of dirt, burrs, etc., and blow them out with clean air before connecting them to the system. The air supply line should contain an air filter to remove harmful dirt and moisture from the compressed air.



Use a normally closed 4-way air solenoid valve to control the dispensing valve. Attach the air supply lines from the 4-way valve to the 1/8 npt air inlets of the dispensing valve.

Connect the Fluid Lines

Connect a grounded fluid line from the pump to the fluid inlet of the dispensing valve. You should install a fluid pressure regulator to control fluid pressure to the dispensing valve. A regulator enables you to control fluid pressure more accurately than by regulating air pressure to the pump.

Install a fluid filter to remove particles and sediment which may clog the nozzle.

 **WARNING**

Two accessories are required in your system: a bleed-type master air valve and a fluid drain valve. These accessories help reduce the risk of serious injury including fluid injection, splashing in the eyes or on the skin, and injury from moving parts if you are adjusting or repairing the pump.

The bleed-type master air valve is required only with air-powered pumps. It relieves air trapped between this valve and the pump after the air regulator is shut off. Trapped air can cause the pump to cycle unexpectedly. Locate the valve close to the pump.

The fluid drain valve helps relieve fluid pressure in the displacement pump, hose, and dispensing valve; triggering the valve to relieve pressure may not be sufficient.

Operation

Settings and Adjustments

Set the actuating air to at least 75 psi (517 kPa, 5.17 bar) and start the pump. Adjust the pump speed and pressure to obtain the desired flow rate. Always use the lowest pump speed necessary to get the results you want.

To decrease needle travel, turn the cap (10) clockwise; to increase, turn counterclockwise. The valve is factory set at one open turn. **The maximum setting is four turns open.**

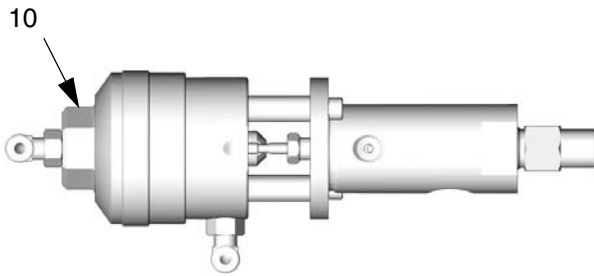



FIG. 1

5. Leave the drain valve(s) open until you are ready to dispense again.

If you suspect that the dispensing valve or hose is completely clogged, or that pressure has not been fully relieved after following the steps above, very slowly loosen the hose end coupling and relieve pressure gradually, then loosen completely. Now clear the valve or hose.

Pressure Relief Procedure

 **WARNING**

Follow **Pressure Relief Procedure** when you stop spraying and before cleaning, checking, servicing, or transporting equipment. Read warnings, page 3.

1. Shut off the power to the pump.
2. Close the bleed-type master air valve (required with air powered pumps).
3. Actuate the dispensing valve to relieve pressure.
4. Open the pump drain valve (required in your system) to help relieve fluid pressure in the displacement pump. Actuating the dispensing valve to relieve pressure may not be sufficient. Have a container ready to catch the drainage.

Maintenance

Clean the Dispensing Valve Daily

CAUTION

Be sure the solvent used is compatible with the fluid being dispensed, to avoid clogging the valve's fluid passages.

WARNING



To reduce the risk of serious injury whenever you are instructed to relieve pressure, always follow the Pressure Relief Procedure on page 6.

An important part of the care and maintenance of your automatic dispensing valve is proper flushing. Flush the valve daily with a compatible solvent until all traces of fluid are removed from the valve passages. **Relieve the pressure** before flushing.

Clean the outside surfaces of the valve by wiping with a soft cloth dampened with a compatible solvent.

CAUTION

Never immerse the entire dispensing valve in solvent. Immersing in solvent removes lubricants and may damage the o-rings.

Flushing

WARNING





To reduce the risk of serious injury whenever you are instructed to relieve pressure, always follow the **Pressure Relief Procedure** on page 6.

Before flushing, be sure the entire system and flushing pails are properly grounded. Refer to Grounding on page 5. **Relieve the pressure**. Always use the lowest possible fluid pressure, and maintain firm metal-to-metal contact between the dispensing valve and the pail during flushing to reduce the risk of fluid injection injury, static sparking, and splashing.

Start the pump and flush the system with a compatible solvent as explained in the instructions for your pump. Check the system under pressure for leaks; if any are found, **relieve the pressure** and repair the leaks. Pressurize the system again and make sure the leaking has stopped.

Troubleshooting

 **WARNING**

Follow **Pressure Relief Procedure** on page 6 when you stop spraying and before cleaning, checking, servicing, or transporting equipment. Read warnings, page 3.

Before servicing this equipment always make sure to **relieve the pressure**.

 Check all possible causes and solutions before disassembling.

Problem	Cause	Solution
Valve will not close.	Fluid needle binding.	Clean, repair.
	Piston o-rings binding.	Repair.
	Obstructed or worn needle or seat.	Clean or replace.
Valve will not open.	Fluid needle binding.	Clean or repair.
	Piston o-rings binding.	Repair.
	No trigger or actuator pressure.	Check, clean all lines.
	Worn or dry piston o-rings.	Replace.
Valve will not dispense.	Pump not operating.	Refer to separate pump manual.
	Fluid line clogged.	Clear.
	Fluid valve closed.	Open.
	Clogged orifice or needle seat.	Clean.

Repair

WARNING



To reduce the risk of serious injury whenever you are instructed to relieve pressure, always follow the **Pressure Relief Procedure** on page 6.

Separating the Air and Fluid Sections

1. Relieve the pressure.
2. Flush the valve with a compatible solvent.
3. Relieve the pressure after flushing and disconnect the fluid hoses.
4. Remove screws (24) and spacers (23). See FIG. 2.
5. Separate the air and fluid sections. See FIG. 3.

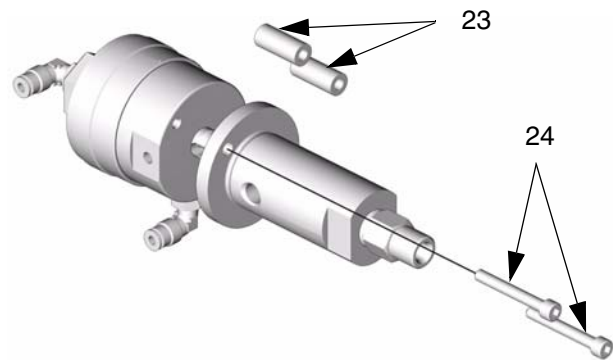

FIG. 2

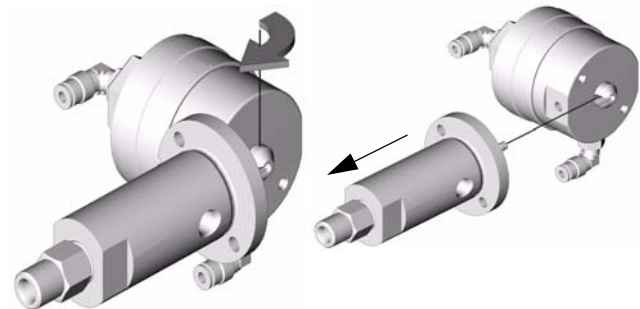



FIG. 3

Fluid Section Disassembly

1. Remove nut (12). See FIG. 4.
2. Remove the seat (20).

 Copper gasket (16) will probably remain in valve body (8). There is no need to remove copper gasket unless the valve is being rebuilt using kit 248429. See **Parts** on page 12.

3. Push the needle (19) from the top while pulling from the bottom.

 Needle may be hard to remove.

4. Push packings out of top of housing (11, 14, 15, 18).
5. Clean, inspect, and replace as needed.

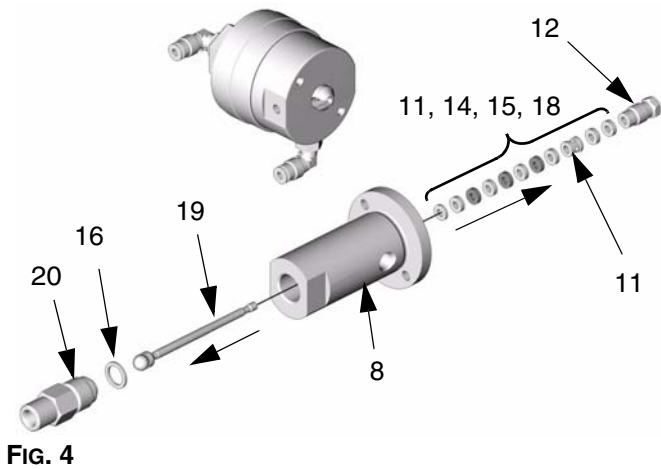

Air Section Disassembly

1. Unscrew the valve cap (10) from the housing (7) and separate. Inspect o-ring (4). See FIG. 5.
2. Push the pistons (9,13) up from the bottom of the housing (7) to inspect o-rings (5, 6). See FIG. 6.
3. Remove spring (22) from valve cap (10).
4. Clean, inspect, replace as needed.

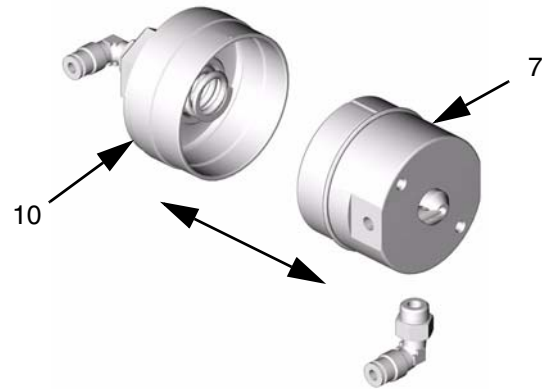

FIG. 5

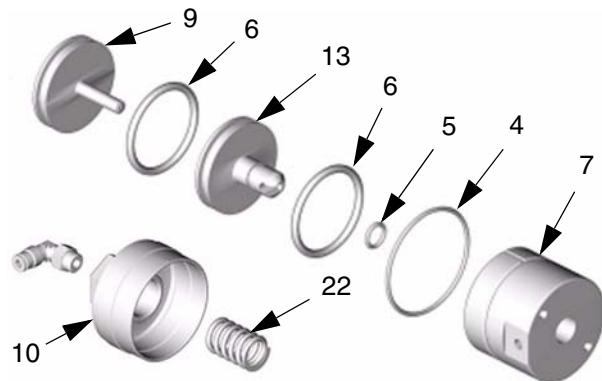

FIG. 6

Reassembly

Fluid Section

Reassemble the valve using new parts as necessary. Soak new leather packings (15) in oil for 24 hours prior to reassembly. The standard packing arrangement is six UHMWPE (18) and three leathers (15).

1. Insert the pin (19) through the valve body (8). See FIG. 7.
2. Assemble packings onto the pin (19) as shown in FIG. 7 and FIG. 8.
3. Screw the seat (20) onto the valve body (8) and torque seat (20) to 45 ± 5 ft - lbs.
4. Assemble the remaining parts of the valve in reverse order as shown in the **Fluid Section Disassembly** section on page 10.



When reassembling lubricate spring (22), o-rings (4, 5, 6, 18) and threads with water resistant grease. Torque the seat (20) to 45 ± 5 ft. - lbs., the screws (24) to 60 ± 10 in - lbs., and the packing nut (12) to 40 ± 10 in - lbs. See **Parts** on page 12.

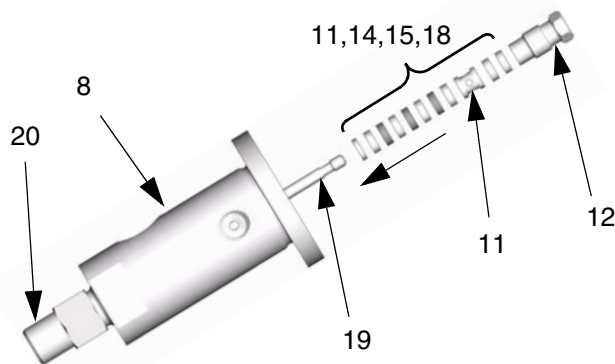

FIG. 7

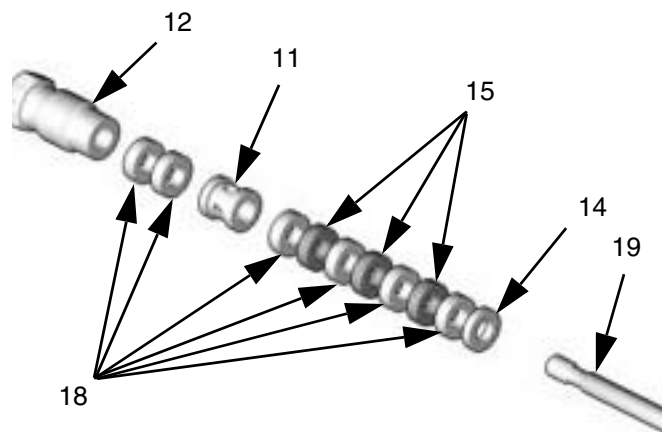

FIG. 8

Air Section

1. Insert spring (22) into valve cap (10). See FIG. 6.
2. Push the pistons (9,13) into the bottom of the housing (7).
3. Screw the valve cap (10) onto the housing (7) only until slight resistance is felt as the cap (10) contacts the o-ring (4) on the housing (7). **Do not tighten the valve cap (10) at this time.** See FIG. 5.

Connecting the Air and Fluid Sections

1. Join the air and fluid sections together. See FIG. 3.
2. Insert spacers(23) and screws (24) and torque to 60 ± 10 in. lbs (6.77 ± 1.1 N*m). See FIG. 2.
3. Screw the valve cap (10) down tight with the housing (7).
4. Unscrew the valve cap (10) one complete turn for the factory needle setting, or unscrew cap to setting prior to repair.



To decrease needle travel, turn the cap (10) clockwise; to increase, turn counterclockwise. The valve is factory set at one open turn. **The maximum setting is four turns open.**

Parts

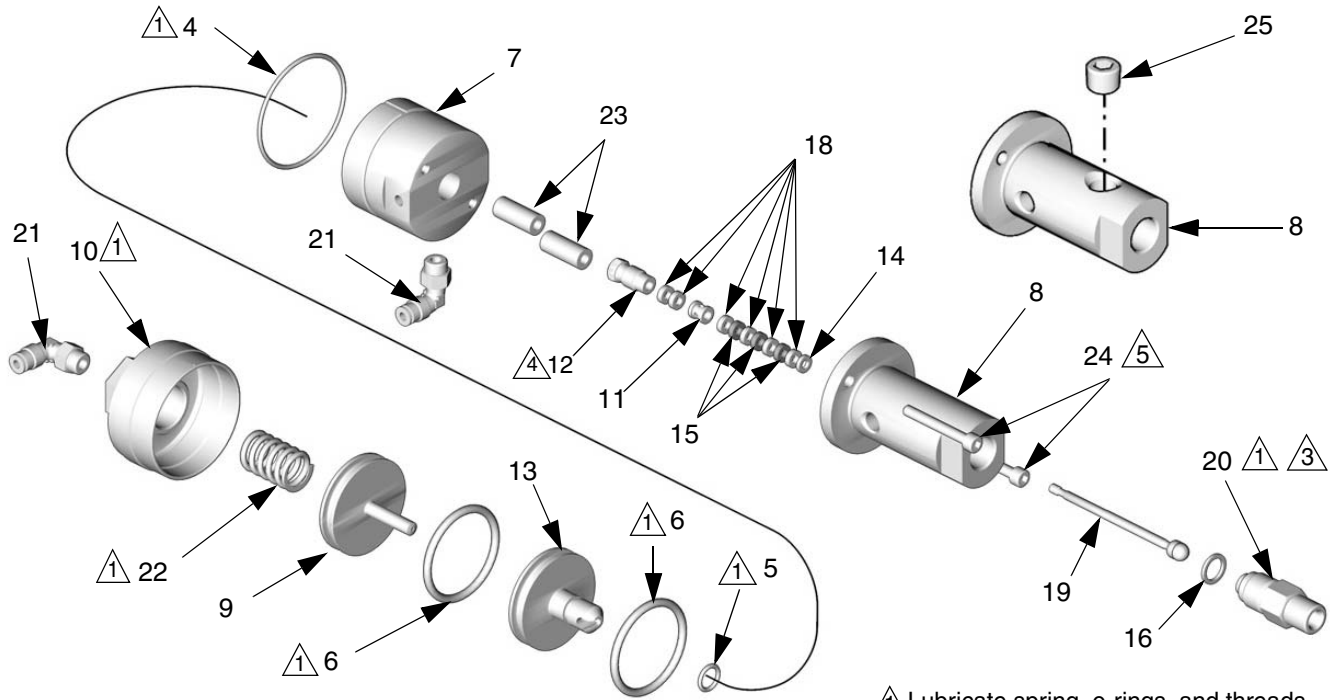

① Lubricate spring, o-rings, and threads with water resistant grease

③ Torque to 45 ± 5 ft. - lbs

④ Torque to 40 ± 10 in - lbs

⑤ Torque to 60 ± 10 in - lbs

Ref. No.	Part No.	Description	Qty.	Ref. No.	Part No.	Description	Qty.
4*	106274	O-Ring; buna-N	1	18*	181523	Packing; UHMWPE	6
5*	155685	O-Ring; buna-N	1	19*	287250	Needle Assembly	1
6*	156593	O-Ring; buna-N	2	20	287221	Seat	1
7	15D260	Housing	1	21	114151	Elbow, swivel; 1/8 npt x 5/32 OD tube	2
8	15D261	Body, valve (model 287222)	1	22	118695	Spring	1
	15G479	Body, valve (model 287787)	1	23	15D455	Spacer	2
9	15D262	Piston, valve	1	24	110420	Screw, 10-24 UNC x 1.5 in.	2
10	15D263	Cap, valve	1	25	101970	Plug, pipe, HDLS (model 287787 only)	1
11*	15D264	Spacer, valve	1				
12	15D955	Packing Nut	1				
13	15D453	Bottom Piston	1				
14*	166255	Gland, packing	1				
15*	166258	Packing; leather	3				
16*	167730	Gasket; copper	1				
17▲	172479	Warning Tag (not shown)	1				

▲ Replacement Danger and Warning labels, tags, and cards are available at no cost.

* Parts included in Kit 248429 (purchased separately).

Technical Data

Air Specifications

- Maximum Air Input Pressure 100 psi (0.7 MPa, 7 bar)
- Minimum Air Pressure 75 psi (0.5 MPa, 5.2 bar)

Fluid Specifications

- Maximum Fluid Working Pressure. 5000 psi (34.5 MPa, 345 bar) Maximum Working Pressure
- Fluid wetted parts 303 SST, 416 SST, Tungsten carbide (with nickel binder), copper, chrome, UHMWPE

Weight 2.3 lbs. (1.04 kg)

Dimensions

Measurements do not include air fittings.

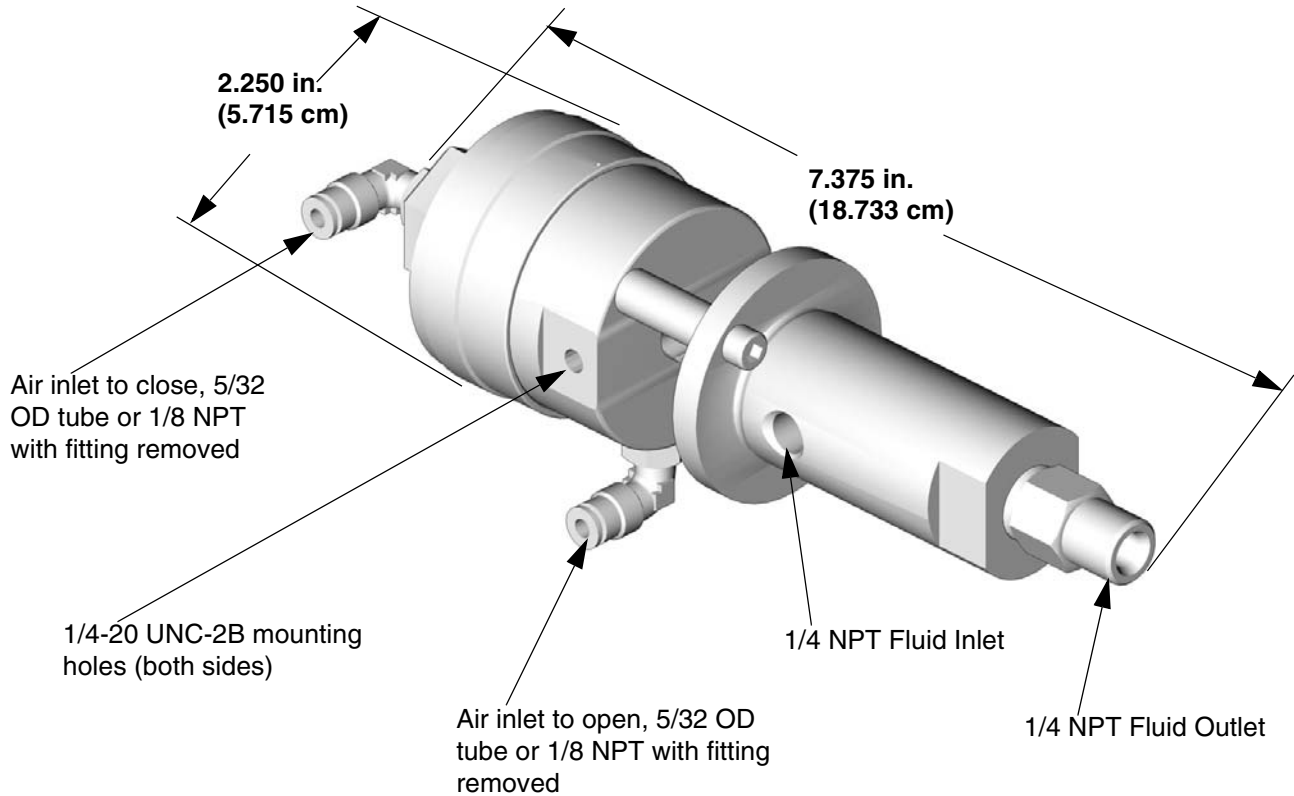

Graco Standard Warranty

Graco warrants all equipment referenced in this document which is manufactured by Graco and bearing its name to be free from defects in material and workmanship on the date of sale to the original purchaser for use. With the exception of any special, extended, or limited warranty published by Graco, Graco will, for a period of twelve months from the date of sale, repair or replace any part of the equipment determined by Graco to be defective. This warranty applies only when the equipment is installed, operated and maintained in accordance with Graco's written recommendations.

This warranty does not cover, and Graco shall not be liable for general wear and tear, or any malfunction, damage or wear caused by faulty installation, misapplication, abrasion, corrosion, inadequate or improper maintenance, negligence, accident, tampering, or substitution of non-Graco component parts. Nor shall Graco be liable for malfunction, damage or wear caused by the incompatibility of Graco equipment with structures, accessories, equipment or materials not supplied by Graco, or the improper design, manufacture, installation, operation or maintenance of structures, accessories, equipment or materials not supplied by Graco.

This warranty is conditioned upon the prepaid return of the equipment claimed to be defective to an authorized Graco distributor for verification of the claimed defect. If the claimed defect is verified, Graco will repair or replace free of charge any defective parts. The equipment will be returned to the original purchaser transportation prepaid. If inspection of the equipment does not disclose any defect in material or workmanship, repairs will be made at a reasonable charge, which charges may include the costs of parts, labor, and transportation.

THIS WARRANTY IS EXCLUSIVE, AND IS IN LIEU OF ANY OTHER WARRANTIES, EXPRESS OR IMPLIED, INCLUDING BUT NOT LIMITED TO WARRANTY OF MERCHANTABILITY OR WARRANTY OF FITNESS FOR A PARTICULAR PURPOSE.

Graco's sole obligation and buyer's sole remedy for any breach of warranty shall be as set forth above. The buyer agrees that no other remedy (including, but not limited to, incidental or consequential damages for lost profits, lost sales, injury to person or property, or any other incidental or consequential loss) shall be available. Any action for breach of warranty must be brought within two (2) years of the date of sale.

GRACO MAKES NO WARRANTY, AND DISCLAIMS ALL IMPLIED WARRANTIES OF MERCHANTABILITY AND FITNESS FOR A PARTICULAR PURPOSE, IN CONNECTION WITH ACCESSORIES, EQUIPMENT, MATERIALS OR COMPONENTS SOLD BUT NOT MANUFACTURED BY GRACO. These items sold, but not manufactured by Graco (such as electric motors, switches, hose, etc.), are subject to the warranty, if any, of their manufacturer. Graco will provide purchaser with reasonable assistance in making any claim for breach of these warranties.

In no event will Graco be liable for indirect, incidental, special or consequential damages resulting from Graco supplying equipment hereunder, or the furnishing, performance, or use of any products or other goods sold hereto, whether due to a breach of contract, breach of warranty, the negligence of Graco, or otherwise.

FOR GRACO CANADA CUSTOMERS

The Parties acknowledge that they have required that the present document, as well as all documents, notices and legal proceedings entered into, given or instituted pursuant hereto or relating directly or indirectly hereto, be drawn up in English. Les parties reconnaissent avoir convenu que la rédaction du présente document sera en Anglais, ainsi que tous documents, avis et procédures judiciaires exécutés, donnés ou intentés, à la suite de ou en rapport, directement ou indirectement, avec les procédures concernées.

Graco Information

For the latest information about Graco products, visit www.graco.com.

TO PLACE AN ORDER, contact your Graco distributor or call to identify the nearest distributor.

Phone: 612-623-6921 **or Toll Free:** 1-800-328-0211 **Fax:** 612-378-3505

*All written and visual data contained in this document reflects the latest product information available at the time of publication.
Graco reserves the right to make changes at any time without notice.*

Original instructions. This manual contains English. MM 310655

Graco Headquarters: Minneapolis

International Offices: Belgium, China, Japan, Korea

GRACO INC. AND SUBSIDIARIES • P.O. BOX 1441 • MINNEAPOLIS MN 55440-1441 • USA

Copyright 2003 Graco Inc. All Graco manufacturing locations are registered to ISO 9001.

www.graco.com

Revised 07/2011