

Accessory Hopper Kit

312184B

EN



Important Safety Instructions

Read all warnings and instructions in this manual. Save these instructions.

Pressure Relief Procedure



Follow the Pressure Relief Procedure whenever you see this symbol.



This equipment stays pressurized until pressure is manually relieved. To help prevent serious injury from pressurized fluid, such as skin injection, splashing fluid and moving parts, follow the Pressure Relief Procedure when you stop spraying and before cleaning, checking, or servicing the equipment.

1. Engage trigger lock.
2. Turn ON/OFF switch to OFF.
3. Unplug power cord.
4. Disengage trigger lock. Hold metal part of gun against grounded metal pail and trigger gun into pail to relieve pressure.
5. Engage the trigger lock.
6. Open all fluid drain valves in the system, having a waste container ready to catch drainage. Leave drain valve(s) open until you are ready to spray again.
7. If you suspect the spray tip or hose is clogged or that pressure has not been fully relieved after following the steps above, VERY SLOWLY loosen tip guard retaining nut or hose end coupling to relieve pressure gradually, then loosen completely. Clear hose or tip obstruction.

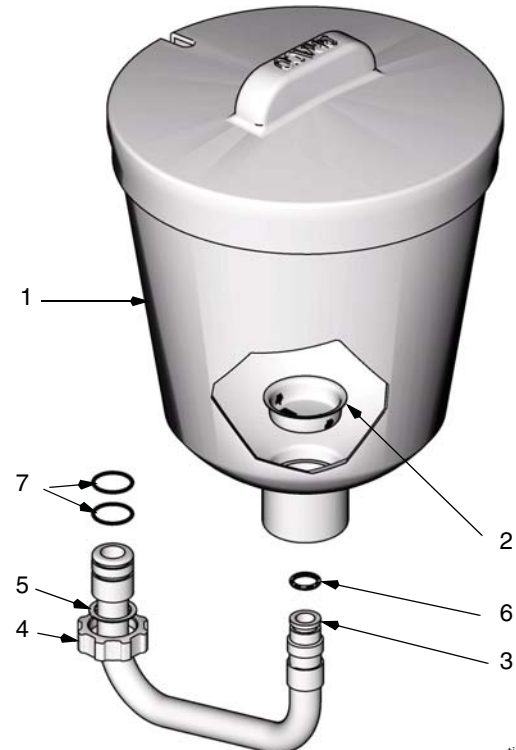

ti25586a

Ref.	Part	Description	Qty
1	188787	HOPPER, 1.5 gallon	1
2	112133	SCREEN, hopper	1
3	287049	TUBE, inlet, hopper	1
4	15E813	NUT, jam	1
5	15B652	WASHER, suction	1
6	104938	PACKING, o-ring	1
7	117559	O-RING	2

1. Follow **Pressure Relief Procedure**.

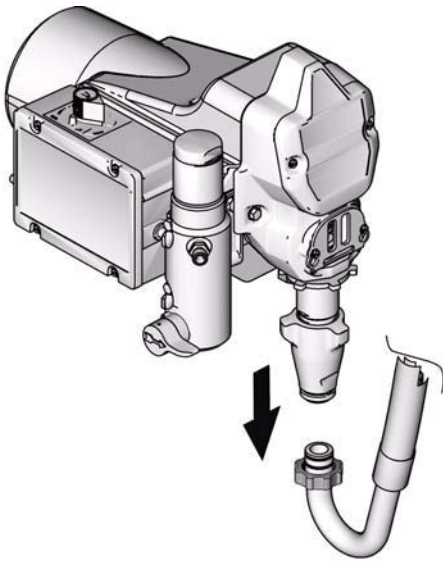

ti25587a

3. Remove hopper lid. Insert hopper tube into pump.

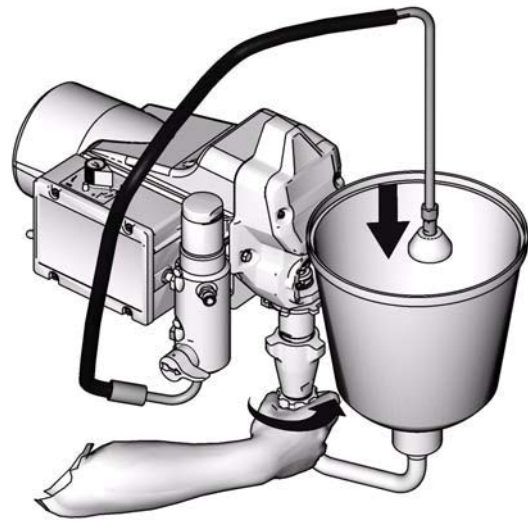

ti25588a

2. Remove suction set.

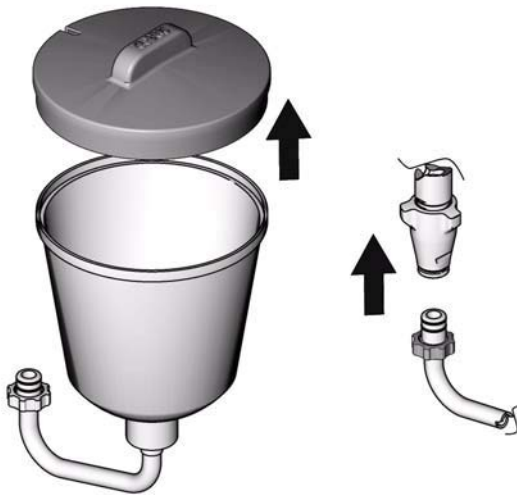

ti25589a

4. Hand-tighten jam nut. Place drain tube into hopper.

Graco Information

For the latest information about Graco products, visit www.graco.com.

For patent information, see www.graco.com/patents.

TO PLACE AN ORDER, contact your Graco distributor or call 1-800-690-2894 to identify the nearest distributor.

*All written and visual data contained in this document reflects the latest product information available at the time of publication.
Graco reserves the right to make changes at any time without notice.*

Original instructions. This manual contains English. MM 312184

Graco Headquarters: Minneapolis

International Offices: Belgium, China, Japan, Korea

GRACO INC. AND SUBSIDIARIES • P.O. BOX 1441 • MINNEAPOLIS MN 55440-1441 • USA

Copyright 2014, Graco Inc. All Graco manufacturing locations are registered to ISO 9001.

www.graco.com

Revision B, January 2015