

Color Change Module Kits

312787J

EN

Includes color change valve stack and control module to add or expand color change function on ProMix® 2KS and ProMix 3KS Electronic Proportioners.
For professional use only.

Approved for use in explosive atmospheres only when used in conjunction with ProMix 2KS or ProMix 3KS Electronic Proportioners.

See page 3 for model information, including maximum working pressure.



Important Safety Instructions

Read all warnings and instructions in this manual. For complete warnings and instructions see your proportioning system manual. Hazard symbols refer to specific procedure risks. Save all instructions.

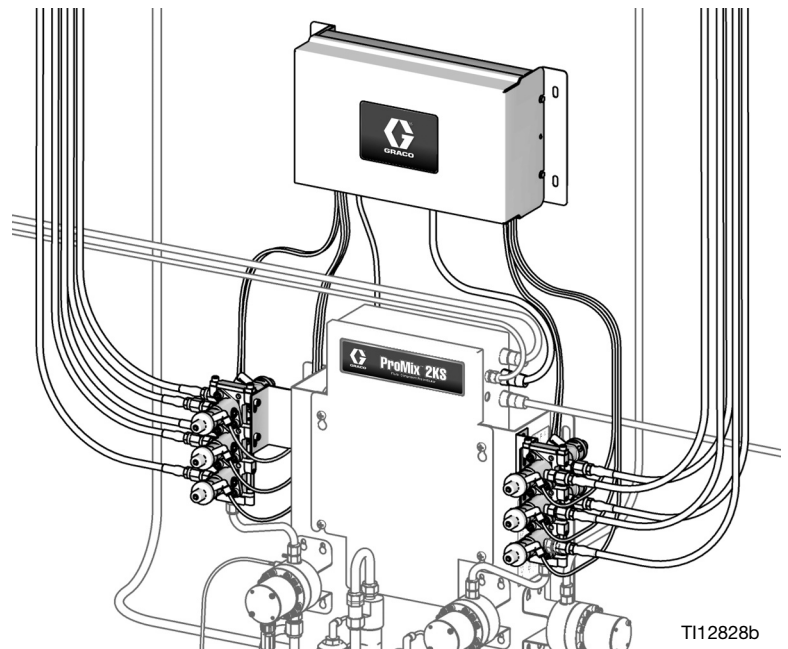

Color Change Kit shown installed in a ProMix 2KS Proportioning System

T112828b

Contents

- Related Manuals** **2**
- Models** **3**
 - Low Pressure Kits 3
 - High Pressure Kits 3
- Installation** **4**
 - Install Color Change Control Module 4
 - Install Color Valve Stacks 7
 - Connect Valve Air Lines 7
 - Connect Valve Fluid Lines 7
 - Color Change Board Switch Settings 7
 - Accessory Dump Valve Kit 7
- Troubleshooting** **10**
 - Color Change Solenoid Valves 10
 - Color Change Board Fuse 10
 - Replace a Solenoid 11
 - Replace the Color Change Board Fuse 11
 - Color Change Board Diagnostics 12
 - Replace the Color Change Board 13
- Schematic Diagrams** **14**
 - System Pneumatic Diagram 14
 - Color Change Module Electrical Schematic ... 15
 - System Electrical Schematic 16
- Parts** **18**
 - Low Pressure Color Change Kits 18
 - High Pressure Color Change Kits 18
 - Color Change Control Modules 20
 - 277752 2-Color Control Module 22
 - 278095 1 Catalyst/1 Flush Control Module (0 Color)
23
- Dimensions** **24**
- Technical Data** **25**
- Graco Standard Warranty** **26**
- Graco Information** **26**

Related Manuals

See the following manuals for additional information on the color change module and kits.

Manual	Description
312775	ProMix 2KS Manual System Installation
312776	ProMix 2KS Manual System Operation
312777	ProMix 2KS Manual System Repair-Parts
312778	ProMix 2KS Manual System Repair-Parts
312779	ProMix 2KS Automatic System Installation
312780	ProMix 2KS Automatic System Operation
313881	ProMix 2KS Automatic System Repair-Parts
313882	ProMix 3KS Installation
313883	ProMix 3KS Manual System Operation
313885	ProMix 3KS Repair-Parts
312782	ProMix 3KS Automatic System Operation
312783	Dispense Valve
312786	Color and Catalyst Change Valve Stacks

Models

Low Pressure Kits

100 psi (0.7 MPa, 7.0 bar) Maximum Air Inlet Pressure

300 psi (2.1 MPa, 21 bar) Maximum Fluid Working Pressure

Kit Part No.	Series	Description
256581	A	2 color
256582		4 color
256583		7 color
256584		12 color
256585		2 color/2 catalyst
256586		4 color/2 catalyst
256587		4 color/4 catalyst
256588		7 color/2 catalyst
256589		7 color/4 catalyst
256590		12 color/2 catalyst
256591		12 color/4 catalyst
256592		13-18 color
256593		13-24 color
256594		13-30 color
256595		1 catalyst/1 flush (0 color)

High Pressure Kits

100 psi (0.7 MPa, 7.0 bar) Maximum Air Inlet Pressure

3000 psi (21 MPa, 210 bar) Maximum Fluid Working Pressure

Kit Part No.	Series	Description
256596	A	2 color
256597		4 color
256598		7 color
256599		12 color
256600		2 color/2 catalyst
256601		4 color/2 catalyst
256602		4 color/4 catalyst
256603		7 color/2 catalyst
256604		7 color/4 catalyst
256605		12 color/2 catalyst
256606		12 color/4 catalyst
256607		13-18 color
256608		13-24 color
256609		13-30 color
256610		1 catalyst/1 flush (0 color)

Installation

<ul style="list-style-type: none"> • To avoid electric shock, turn off equipment power and shut off power at main circuit breaker before installing. • All electrical wiring must be done by a qualified electrician and comply with all local codes and regulations. • Do not substitute system components as this may impair intrinsic safety. 						

<p>To reduce the risk of serious injury, including fluid injection, relieve pressure before installing the kit. Follow the Pressure Relief Procedure in the ProMix 2KS Operation or Service manual.</p>						

Install Color Change Control Module

Location

Install the color change control module (101) near the fluid station. The module is approved for use in a hazardous location. Also see your system installation manual. See FIG. 1.

Mounting

1. See **Dimensions**, page 24.
2. Ensure that the wall and mounting hardware are strong enough to support the weight of the equipment, fluid, hoses, and stress caused during operation.
3. Using the equipment as a template, mark the mounting holes on the wall at a convenient height for the operator and so equipment is easily accessible for maintenance.
4. Drill mounting holes in the wall. Install anchors as needed.
5. Bolt equipment securely.

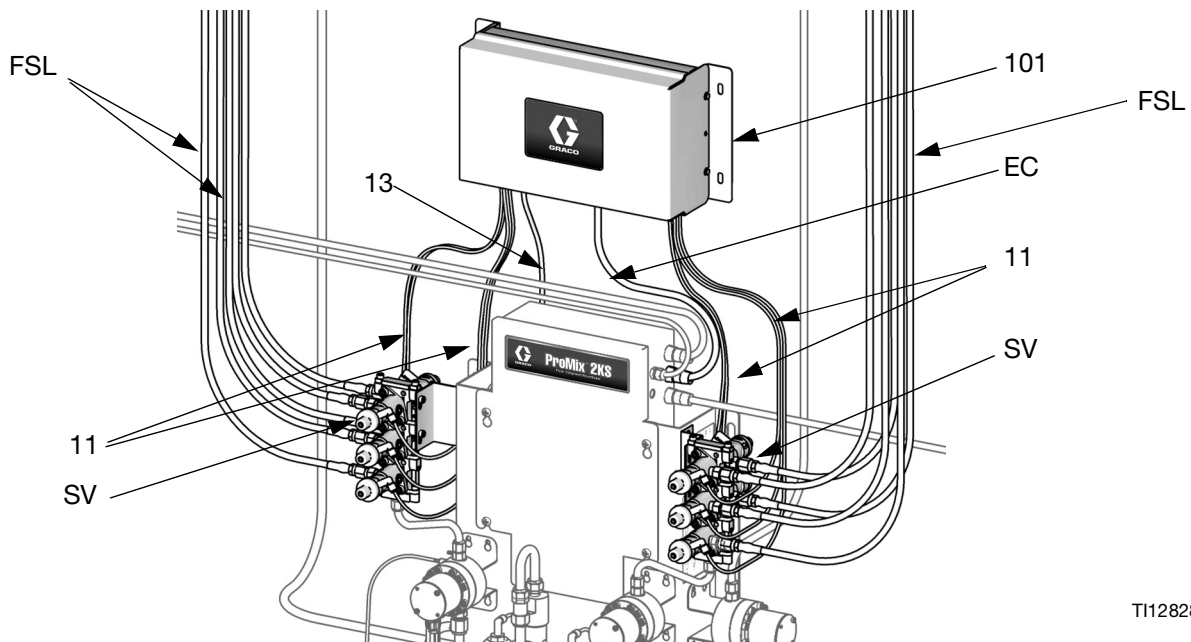

T112828b

FIG. 1: Control Module Installation

Connect Module to Fluid Station Board

NOTICE
To avoid damaging circuit board when servicing, wear grounding strap on wrist and ground appropriately.

1. Remove the Fluid Station cover.
2. See Fig. 1. Connect a 5-pin electrical cable (EC) from the labeled connection port **C.C.** (J11) on the fluid station input control board to the color change board. Also see FIG. 2 and FIG. 5.

NOTE: See Table 1 for a list of available cables to connect the color change control module and fluid station. Recommended length is 3 ft (1.0 m) or 6 ft (2.0 m).

Table 1: Intrinsically Safe CAN Cables

Part No.	Length in ft (m)
15U531	2 (0.6)
15U532	3 (1.0)
15V205	6 (2.0)
15V206	10 (3.0)
15V207	15 (5.0)
15V208	25 (8.0)
15U533	50 (16.0)
15V213	100 (32.0)

To Install a Second Control Module

If you are using two color change modules to add colors, connect a 5-pin electrical cable from the first color change board to the second color change board. See FIG. 5.

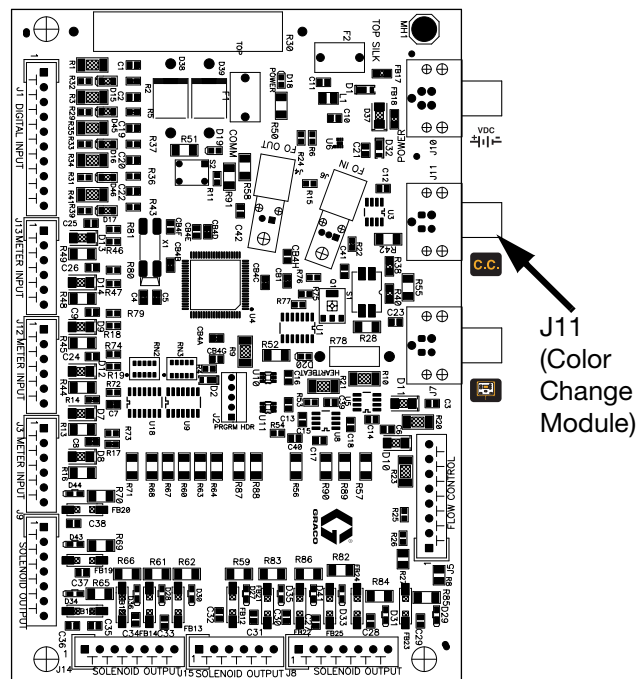
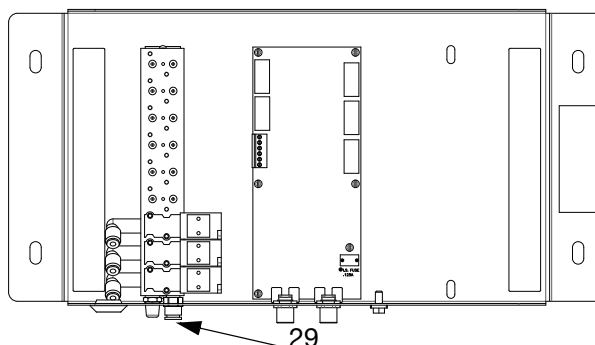

FIG. 2: Fluid Station Control Board Connection

Connect Air Supply to Control Module

Connect a 1/4 in. (6 mm) OD tube (13) between the system's air manifold (at the bottom rear of the fluid station) and the module air inlet fitting (29). See FIG. 3.

The air supply must be clean and dry. Use a 5 micron filter. Regulate the air pressure to 75-100 psi (0.52-0.70 MPa, 5.25-7.0 bar).



TI12824a

FIG. 3: Solenoid Air Connection

Install Color Valve Stacks

1. Install the bracket (17) on the fluid station (FS) with two screws (20). See FIG. 4.
2. Install the color or catalyst valve stack (VS) to the bracket (17) with two screws (20).

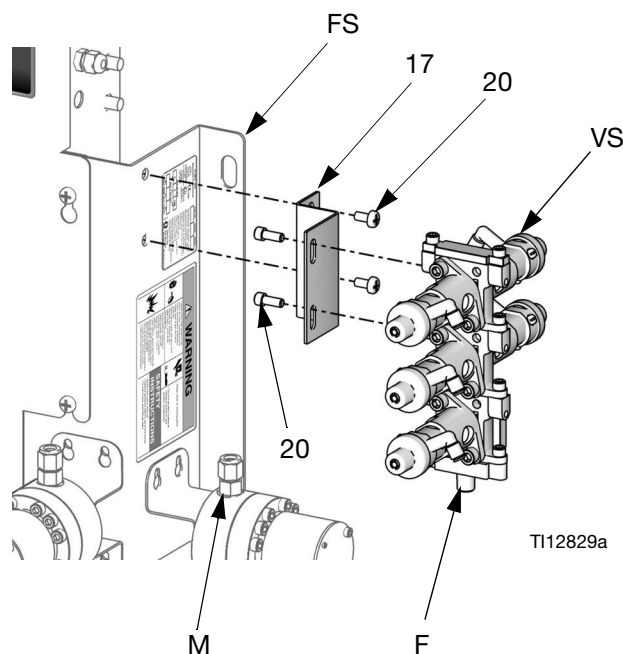

FIG. 4: Install Valve Stacks

Connect Valve Air Lines

See FIG. 1. Connect 5/32 in. (4 mm) OD air tubes (11) from the valve solenoids to the air inlets of each valve. Refer to the **System Pneumatic Diagram**, page 14, and the label inside the color control module.

NOTE: The high pressure color change valves use a spring-operated exhaust which does not require a second air line.

Connect Valve Fluid Lines

1. See FIG. 1. Connect fluid supply lines (FSL) to the 1/4 npt(f) inlet of each valve adapter. Supply solvent to one valve (SV) at the top of the stack,

NOTICE

Verify that all unused fluid ports on the color change valve stack are plugged before operation. An open port will leak fluid.

2. Connect the hose (19) from the manifold stack fluid outlet (F) to the flow meter inlet (M). FIG. 4.

NOTICE

A check valve is recommended on all dead head valves to prevent color crossover if two valves are open at the same time.

Color Change Board Switch Settings

Set switches S3-S6 on the color change board(s) as shown in Table 2 and FIG. 5, depending on the number of color change boards and color change modules being used in your system.

Accessory Dump Valve Kit

15V821 Dump Valve Kit, for Wall Panel Systems

15V822 Dump Valve Kit, for RoboMix Systems

Accessory Dump Valve Kits are available. The kits include one dump valve, one solenoid, all necessary parts for installation, and instruction manual 312786. Order one kit for each dump valve desired.

Table 2: Color Change Board Switch Settings for ProMix 2KS Systems

Two Color Change Boards								
Color Change Board 1				Color Change Board 2				Effect on System
S3	S6	S5	S4	S3	S6	S5	S4	
Termination Resistor	Board ID	Catalyst On/Off	Color On/Off	Termination Resistor	Board ID	Catalyst On/Off	Color On/Off	
OFF	ON	ON	ON	ON	OFF	NOT USED		4 catalyst/30 color valves
OFF	ON	OFF	ON	ON	OFF	NOT USED		0 catalyst/30 color valves
One Color Change Board								
ON	ON	ON	ON	NOT PRESENT				4 catalyst/12 color valves
ON	ON	ON	OFF	NOT PRESENT				4 catalyst/0 color valves
ON	ON	OFF	ON	NOT PRESENT				0 catalyst/12 color valves

Table 3: Color Change Board Switch Settings for ProMix 3KS Systems

Two Color Change Boards								
Color Change Board 1				Color Change Board 2				Effect on System
S3	S6	S5	S4	S3	S6	S5	S4	
Termination Resistor	Board ID	Catalyst On/Off	Color On/Off	Termination Resistor	Board ID	Component C On/Off	Color On/Off	
OFF	ON	ON	ON	ON	OFF	OFF	ON	4 catalyst valves, 25 color valves
OFF	ON	OFF	ON	ON	OFF	OFF	ON	0 catalyst valves, 25 color valves
OFF	ON	ON	ON	ON	OFF	ON	ON	4 catalyst valves, 4 component C valves, 25 color valves
OFF	ON	OFF	ON	ON	OFF	ON	ON	4 component C valves, 25 color valves
One Color Change Board								
ON	ON	ON	ON	NOT PRESENT				4 catalyst valves, 12 color valves
ON	ON	ON	OFF	NOT PRESENT				4 catalyst valves, 0 color valves
ON	ON	OFF	ON	NOT PRESENT				0 catalyst valves, 12 color valves

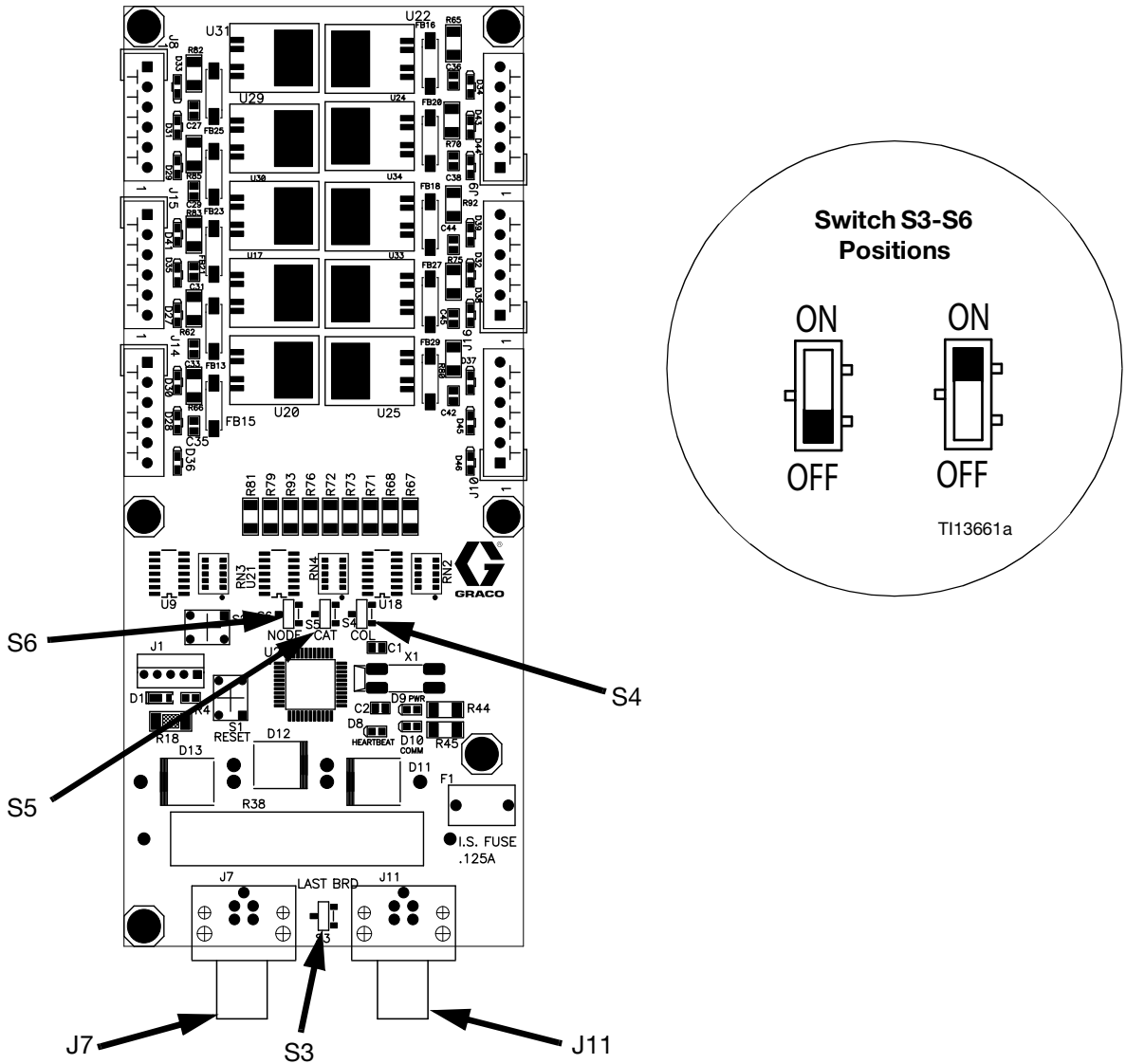

FIG. 5. 256172 Color Change Board Switch Settings

Troubleshooting

Color Change Solenoid Valves

NOTE: Refer to the **Schematic Diagrams**, page 14. If the color change valves are not turning on or off correctly, it could be caused by one of the following.

Cause	Solution
1. Air regulator pressure set too high or too low.	Check air pressure. 80-90 psi (550-630 kPa, 5.5-6.3 bar) is commonly used. Do not go below 75 psi (0.52 MPa, 5.2 bar) or above 100 psi (0.7 MPa, 7 bar).
2. Air or electrical lines damaged or connections loose.	Visually inspect air and electrical lines for kinks, damage, or loose connections. Service or replace as needed.
3. Solenoid failure.	<p>Check the applicable solenoid's LED (see FIG. 7 and Table 4). If lit, proceed with the following checks. If not lit, go to Cause 4.</p> <p>Remove the connector for the applicable solenoid and measure voltage across the pins on the board. If voltage is between 9-15 Vdc, replace the solenoid.</p> <p>Manually operate the valves by removing the color change module cover and pressing and releasing solenoid valve override buttons. FIG. 6.</p> <p>Valves should snap open and shut quickly. If the valves actuate slowly, it could be caused by:</p> <ul style="list-style-type: none"> • Air pressure to the valve actuators is too low. See Cause 1. • Solenoid is clogged. Make sure air supply has 10 micron filter installed. • Something is restricting the solenoid or tubing. Check for air output from air line for corresponding solenoid when valve is actuated. Clear restriction.
4. Fluid station control board or cable failure.	<p>If there is no voltage across the pins on the board or it is less than 9 Vdc, check LEDs D9 and D10 (see FIG. 7 and Table 4). If both are lit and functioning properly, or other solenoids in the module are working properly, replace the color change board.</p> <p>If D9 and D10 are not lit:</p> <ul style="list-style-type: none"> • Check if the cable is disconnected or damaged. • Check the fluid station control board (see the ProMix 2KS Repair-Parts Manual).

Color Change Board Fuse

Problem	Cause	Solution
No power to board. Communication between color change module and fluid station is interrupted.	Color change board fuse (F1) is blown.	Verify condition of fuse. Replace if necessary. See page 11.

Replace a Solenoid

1. Remove air supply pressure from the system. Remove the color change module cover (30).
2. Disconnect the 2 solenoid wires from the color change board (15). See FIG. 7, the **Color Change Module Electrical Schematic** on page 15, and the **System Electrical Schematic** on page 17.
3. Unscrew 2 screws (P) and remove the solenoid (4). See FIG. 6.
4. Install the new solenoid (4).
5. Connect the 2 solenoid wires to the color change board (15). Solenoid wires are polarized (red +12Vdc, black -). Refer to the **Color Change Module Electrical Schematic** on page 15 and the **System Electrical Schematic** on page 17.
6. Reinstall the cover (30).

Replace the Color Change Board Fuse

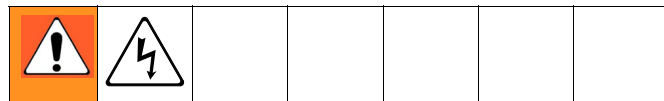

NOTE: Replacing the fuse with a non-Graco fuse voids the IS system safety approval.

Fuse	Part No.	Description
F1	123690	Fuse; 125 mA, intrinsically safe

1. Remove electrical power from the system. Remove the color change module cover (30).
2. Locate fuse (F1) on the color change board. See FIG. 7. Remove the screw and metal strap.
3. Pull the fuse away from the board.
4. Install new fuse (F1). Reinstall the strap over the fuse.
5. Reinstall the cover (30). Restore electrical power to the system.

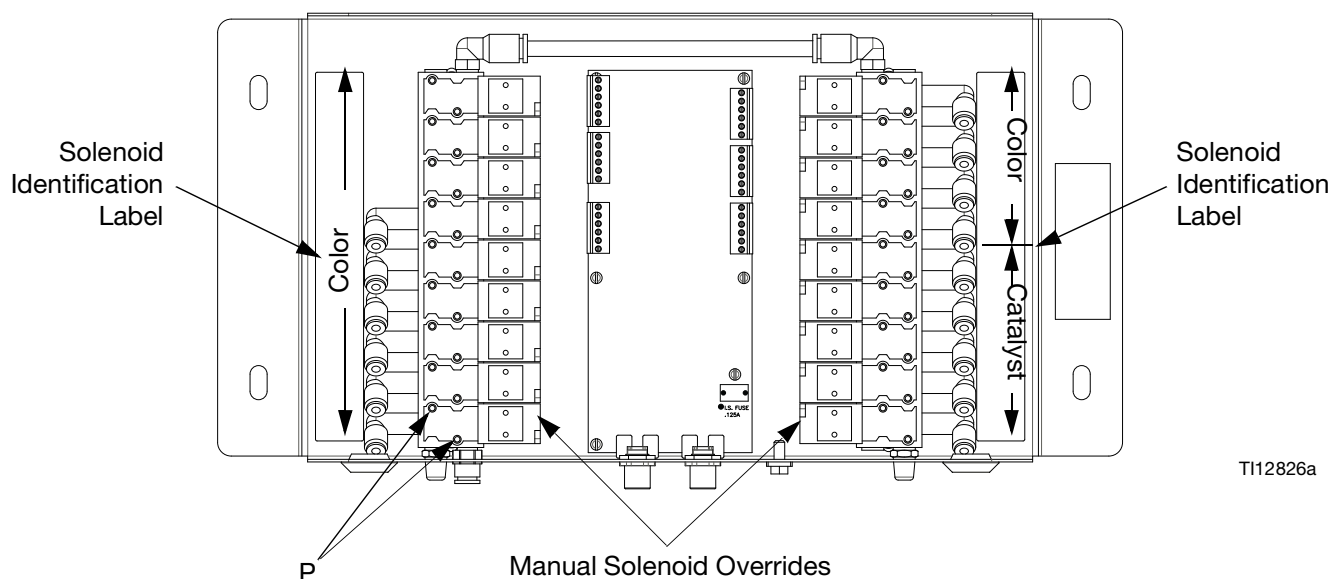

T112826a

FIG. 6: Color Change Solenoids

Color Change Board Diagnostics

See FIG. 7 and Table 4 to troubleshoot the color change board. Also see the **System Electrical Schematic** on pages 16 and 17.

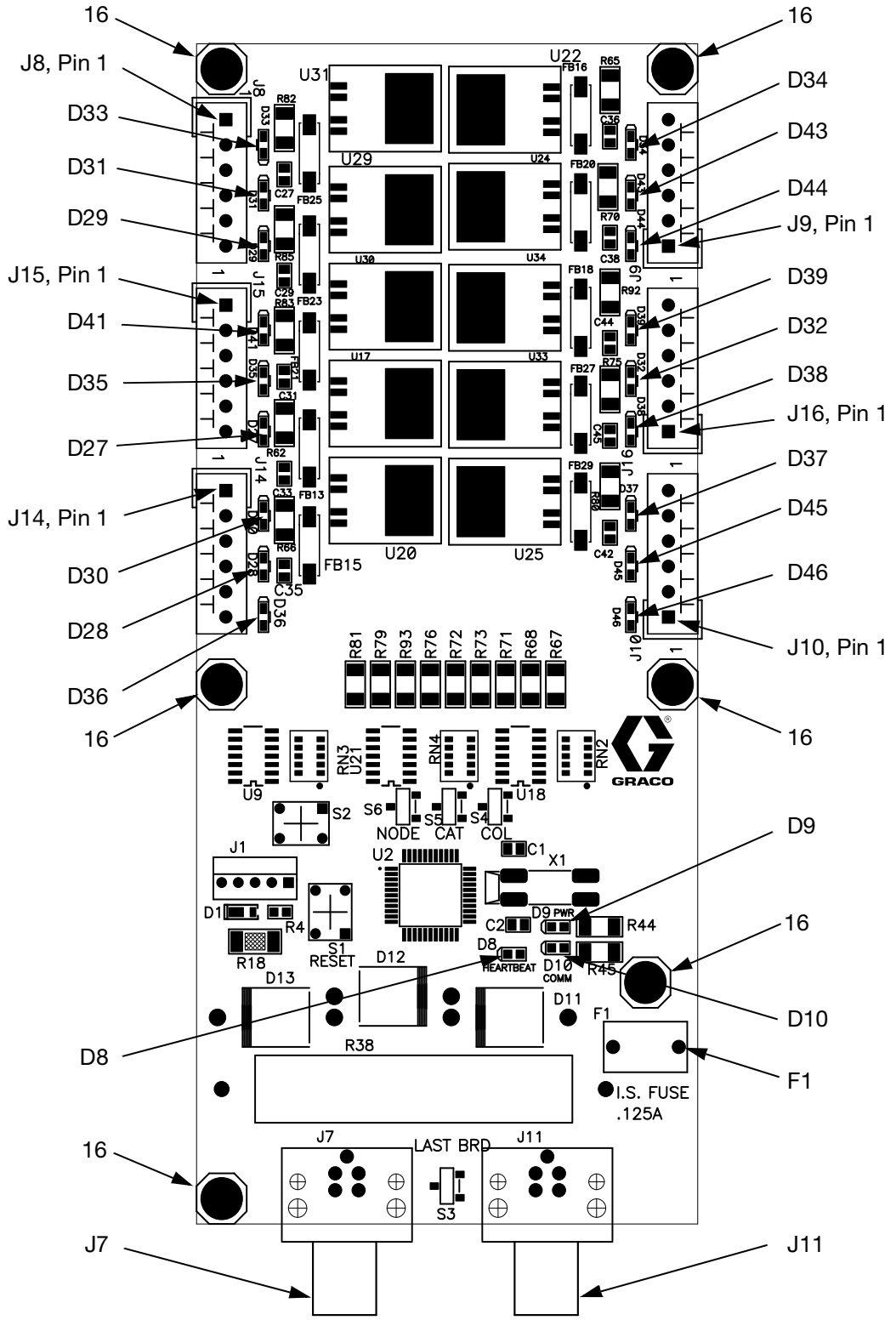
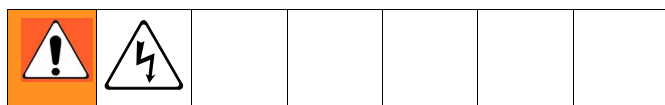

FIG. 7: 256172 Color Change Board

Table 4: Color Change Board Diagnostics

LED	Connector and Pin Nos.	Board 1 Signal Description	Board 2 Signal Description	Diagnosis
D8	n/a	Board OK	Board OK	Blinks (heartbeat) during normal operation.
D9	n/a	Communication (yellow)	Communication (yellow)	Turns on when board is communicating with ProMix 2KS.
D10	J7	Power	Power	Turns on when power is supplied to the board.
D27	J15, 5 & 6	Color 3	Color 16	D27 through D46 turn on when ProMix 2KS sends a signal to actuate the related solenoid valve.
D28	J14, 3 & 4	Color 1	Color 14	
D29	J8, 5 & 6	Color 6	Color 19	
D30	J14, 1 & 2	Color 2	Color 15	
D31	J8, 3 & 4	Color 7	Color 20	
D32	J16, 3 & 4	Catalyst 4	Color 26	
D33	J8, 1 & 2	Color 8	Color 21	
D34	J9, 5 & 6	Color 9	Color 22	
D35	J15, 3 & 4	Color 4	Color 17	
D36	J14, 5 & 6	Solvent (Color)	Color 13	
D37	J10, 5 & 6	Catalyst 2	Color 28	
D38	J16, 1 & 2	Catalyst 3	Color 27	
D39	J16, 5 & 6	Color 12	Color 25	
D41	J15, 1 & 2	Color 5	Color 18	
D43	J9, 3 & 4	Color 10	Color 23	
D44	J9, 1 & 2	Color 11	Color 24	
D45	J10, 3 & 4	Catalyst 1	Color 29	
D46	J10, 1 & 2	Solvent (Catalyst)	Color 30	

Replace the Color Change Board



1. Remove electrical power from the system. Remove the color change module cover (30).
2. See FIG. 7 on page 12. Note where each cable is connected, then disconnect all cables from the color change board connectors (J7, J8, J9, J10, J11, J14, J15, J16).
3. Remove the six mounting screws (16) and the board (15).
4. Install the new board (15). Reinstall the screws (16).
5. Reconnect the cables to the proper connectors, as noted in step 2.
6. Reinstall the cover (30). Restore electrical power to the system.

Schematic Diagrams

System Pneumatic Diagram

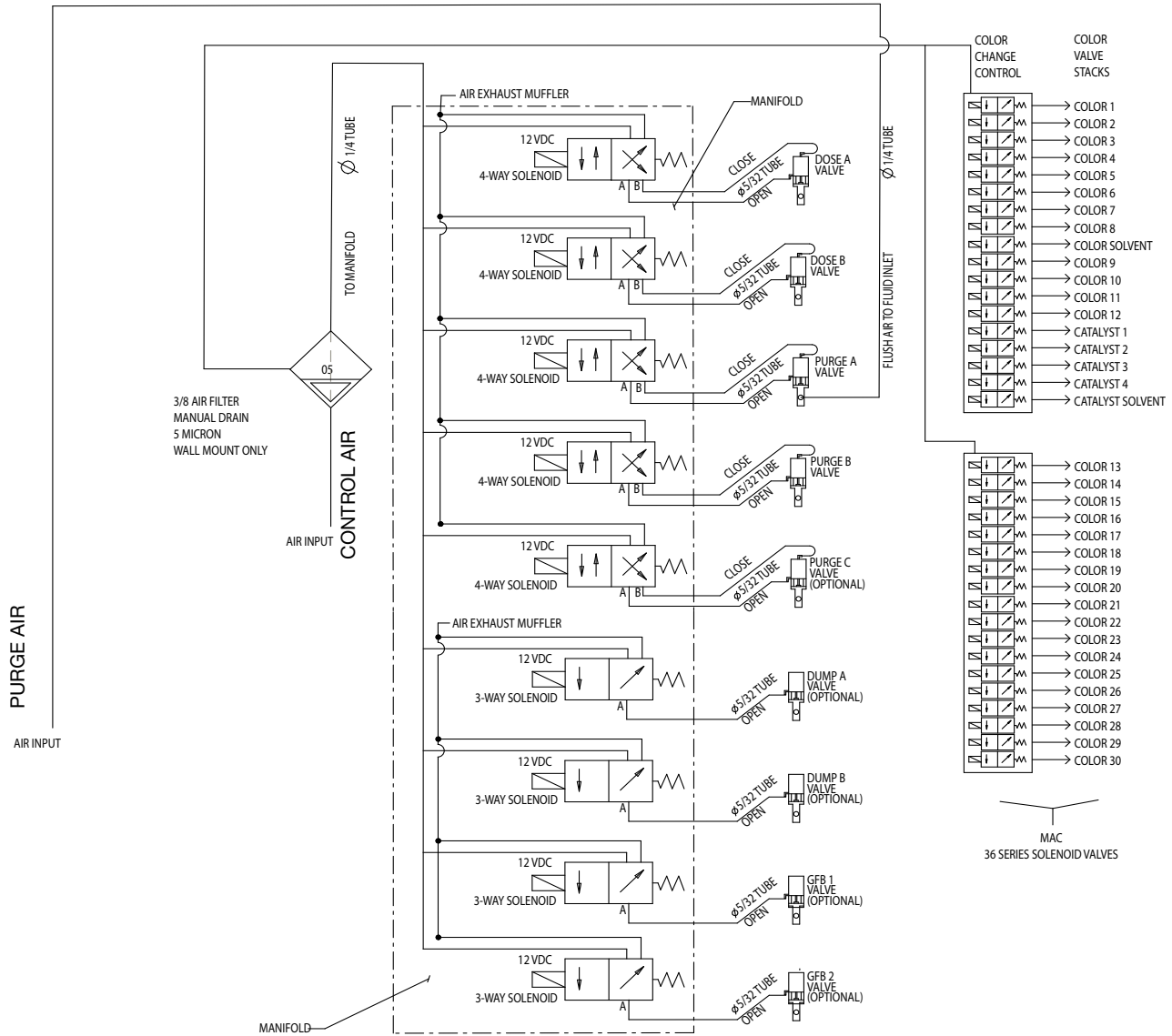

Color Change Module Electrical Schematic

WIRING DIAGRAM

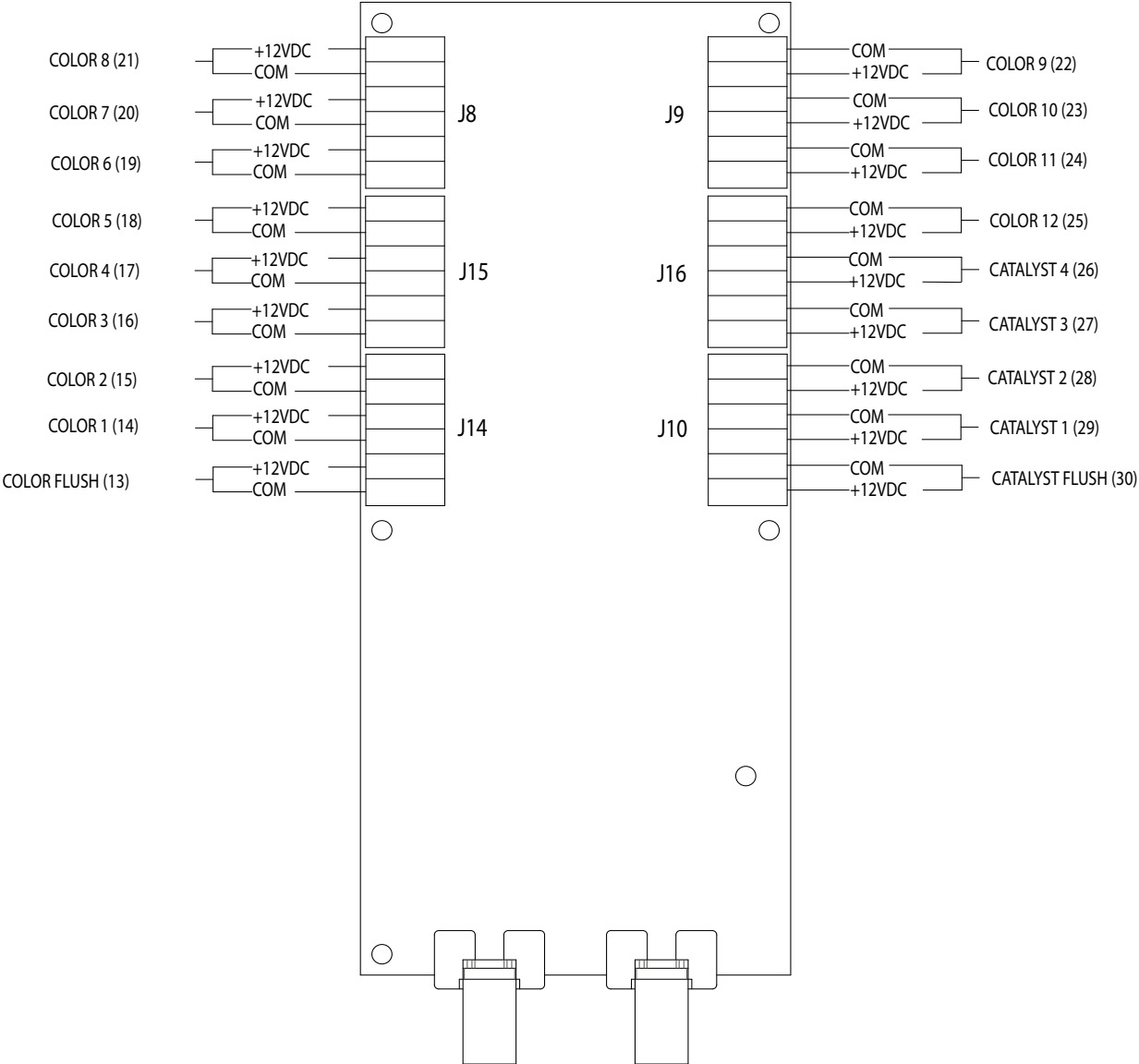

System Electrical Schematic

Non-Hazardous Area

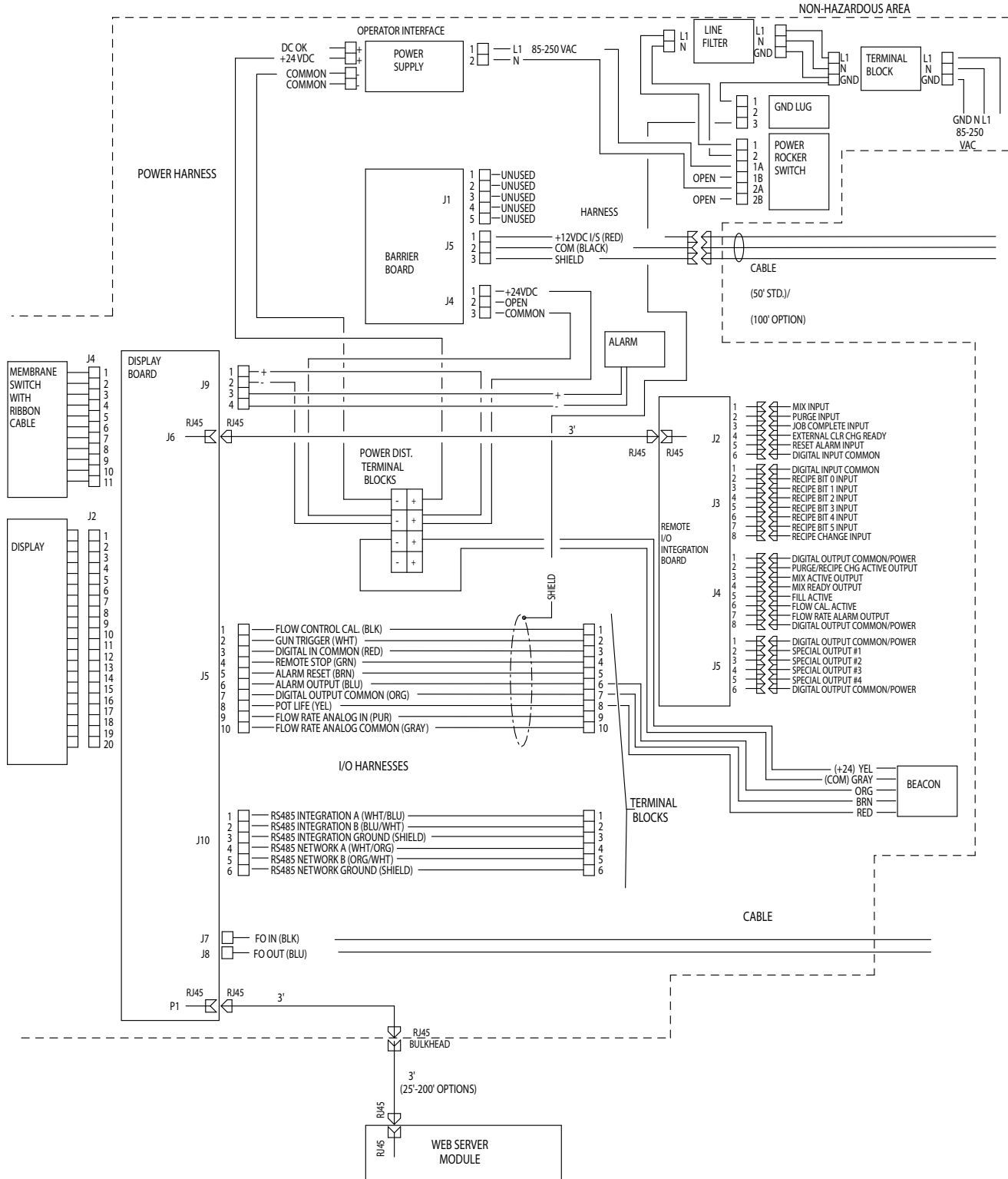

System Electrical Schematic

Hazardous Area

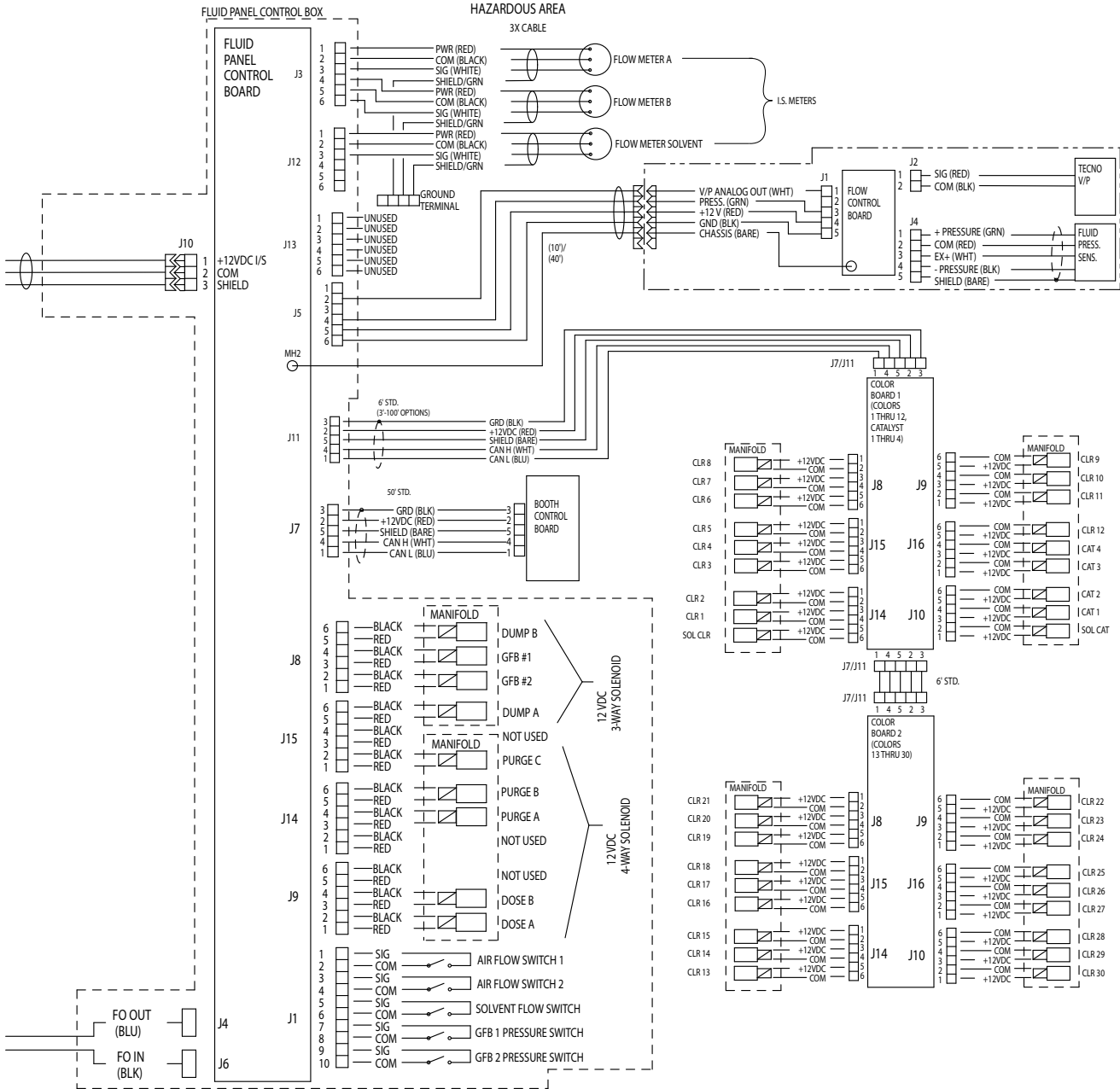

Parts

Low Pressure Color Change Kits

Kit Part No.	Series	Kit Description	Control Module (101; see page 20)	Color Valve Stack (102; see 312783)	Catalyst Valve Stack (103; see 312783)
256581	A	2 color	277752	15V812	none
256582		4 color	277753	15V813	none
256583		7 color	277754	15V814	none
256584		12 color	277755	15V815	none
256585		2 color/2 catalyst	277879	15V812	15V812
256586		4 color/2 catalyst	277880	15V813	15V812
256587		4 color/4 catalyst	277883	15V813	15V813
256588		7 color/2 catalyst	277881	15V814	15V812
256589		7 color/4 catalyst	277884	15V814	15V813
256590		12 color/2 catalyst	277882	15V815	15V812
256591		12 color/4 catalyst	277885	15V815	15V813
256592		13-18 color	278113	256293	none
256593		13-24 color	278114	15V815	none
256594		13-30 color	277885	256305	none
256595		1 catalyst/1 flush	278095	none	256994

High Pressure Color Change Kits

Kit Part No.	Series	Description	Control Module (101; see page 20)	Color Valve Stack (102; see 312783)	Catalyst Valve Stack (103; see 312783)
256596	A	2 color	277752	15V816	none
256597		4 color	277753	15V817	none
256598		7 color	277754	256343	none
256599		12 color	277755	256348	none
256600		2 color/2 catalyst	277879	15V816	15V816
256601		4 color/2 catalyst	277880	15V817	15V816
256602		4 color/4 catalyst	277881	15V817	15V817
256603		7 color/2 catalyst	277882	256343	15V816
256604		7 color/4 catalyst	277883	256343	15V817
256605		12 color/2 catalyst	277884	256348	15V816
256606		12 color/4 catalyst	277885	256348	15V817
256607		13-18 color	278113	256342	none
256608		13-24 color	278114	256348	none
256609		13-30 color	277885	256354	none
256610		1 catalyst/1 flush	278095	none	256995

Color Change Kits Parts

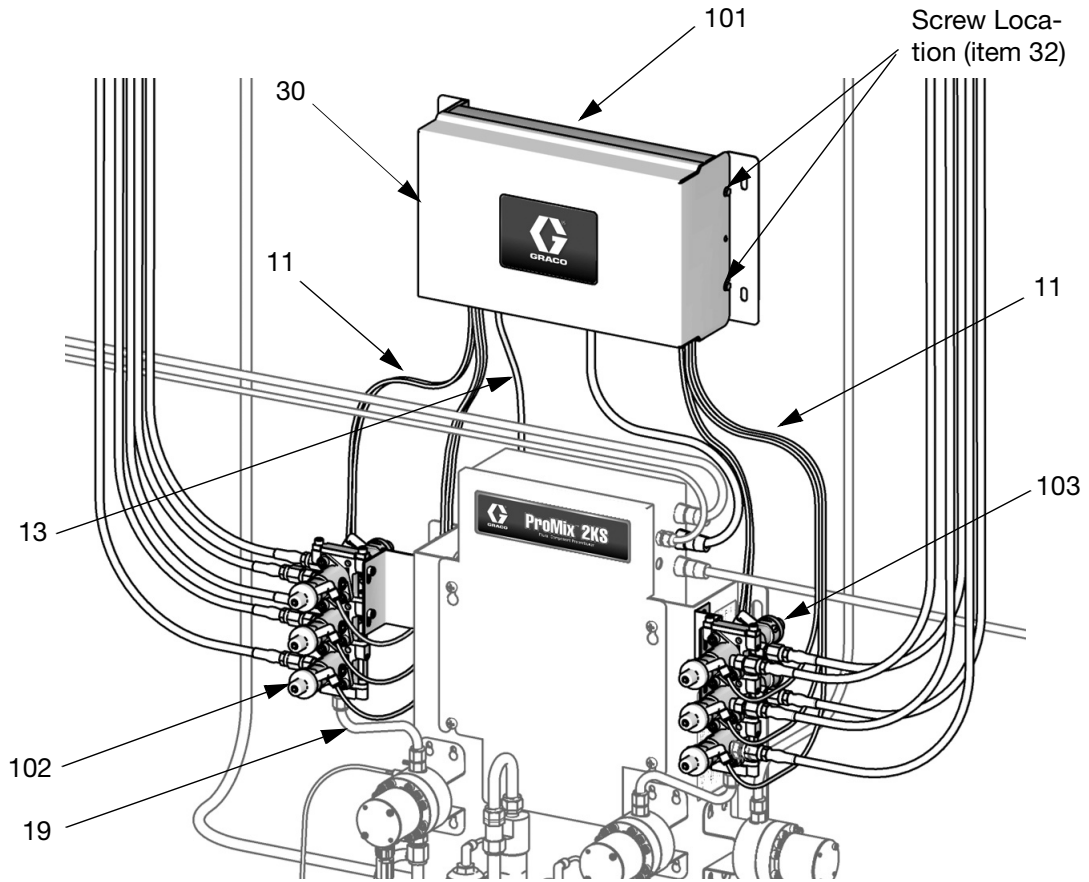

T112828b

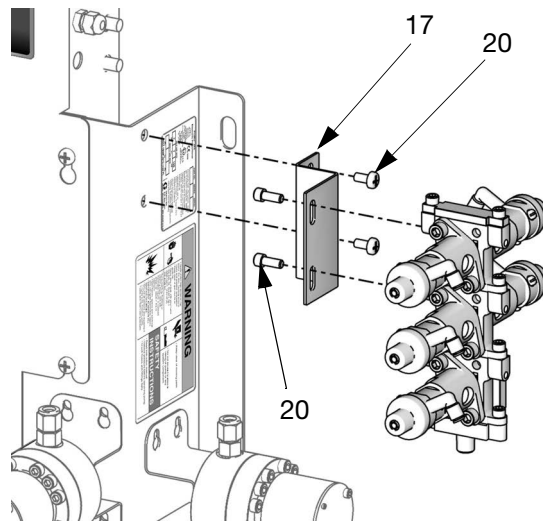

T112829a

Color Change Control Modules

(Ref. No. 101; see page 18)

Ref. No.	Part No.	Description	Qty
1	277752	MODULE, control, color change; see page 22	See Table Below
	278095	MODULE, control, 1 catalyst/1 flush change; see page 23	
2	15T636	MANIFOLD, color change control	
3	114669	SCREW, machine, phillips pan hd; M5 x 10 mm (behind panel 12 and manifold 2)	
4	121324	VALVE, solenoid	
5	121628	SCREW, self-sealing; 4-40 x 1/4 in. (6 mm)	
6	112698	ELBOW, tube; 1/8 npt(m) x 1/4 in. (6 mm) OD tube	
7	121487	GROMMET	
8	109193	ELBOW, tube; 10-32 x 5/32 in. (4 mm) OD tube	
9	100139	PLUG, pipe; 1/8 -27 npt	
10	15V821	KIT, dump valve; see 312786	
11	598095	TUBE; 5/32 in. (4 mm) OD; nylon; see page 19	
13	590332	TUBE; 1/4 in. (6 mm) OD	
14	119162	CONNECTOR, plug, 6 position	
17	15U927	BRACKET, color change; see page 19	
18	C06061	MUFFLER	
19	24N345	HOSE; ptfе; 1/4 npsm(fbe); 1/4 in. (6 mm) ID; 1.5 ft (0.46 m); see page 19	
20	C19798	SCREW, cap, socket-hd; 1/4-20 x 3/8 in. (10 mm); see page 19	

Control Module Part Quantities

Module No.	Ref. Nos.																
	1	2	3	4	5	6	7	8	9	10	11*	13*	14	17	18	19	20
277753	1	0	0	2	0	0	0	2	0	0	10 (3)	0	1	1	0	0	4
277754	1	0	0	5	0	0	0	5	0	0	25 (7.6)	0	2	1	0	0	4
277755	1	1	2	10	0	1	1	10	2	0	50 (15.2)	0.7 (0.2)	3	1	1	0	4
277879 277756‡	1	1	2	3	12	1	1	3	2	0	15 (4.6)	0.7 (0.2)	1	2	1	1	4
277880 277757‡	1	1	2	5	8	1	1	5	2	0	25 (7.6)	0.7 (0.2)	2	2	1	1	4
277882 277758‡	1	1	2	8	10	1	1	8	2	0	40 (12.2)	0.7 (0.2)	3	2	1	1	4
277884 277759‡	1	1	2	13	0	1	1	13	2	0	65 (19.8)	0.7 (0.2)	4	2	1	1	4
277881 277771‡	1	1	2	7	4	1	1	7	2	0	35 (10.7)	0.7 (0.2)	2	2	1	1	4
277883 277772‡	1	1	2	10	0	1	1	10	2	0	50 (15.2)	0.7 (0.2)	3	2	1	1	4
277885 277773‡	1	1	2	15	0	1	1	15	2	0	75 (22.9)	0.7 (0.2)	4	2	1	1	4
278113	1	0	0	3	0	0	0	3	0	0	15 (4.6)	0	1	1	0	0	4
278114	1	1	2	9	0	1	1	9	2	0	45 (13.7)	0.7 (0.2)	3	2	1	0	4

* Quantities for ref. nos. 11 and 13 are in feet (meters). ‡ These modules include two dump valve kits (10).

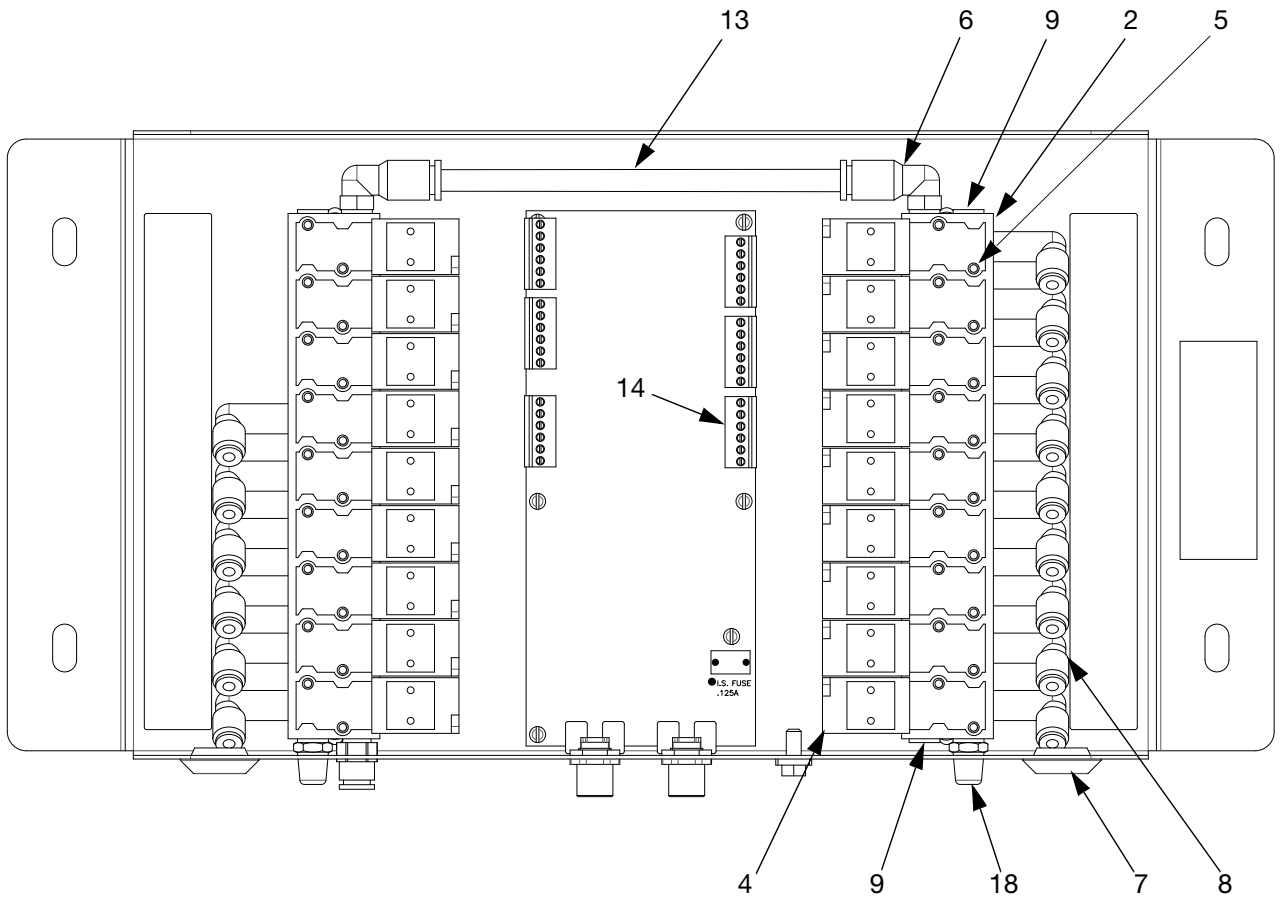

T112826a

277752 2-Color Control Module

Ref. No.	Part No.	Description	Qty
2	15T636	MANIFOLD, color change control	1
3	103833	SCREW, machine, pan hd; 10-32 x 3/8 in. (10 mm) (behind panel 12 and manifold 2)	2
4	121324	VALVE, solenoid	3
5	121628	SCREW, self-sealing; 4-40 x 1/4 in. (6 mm)	12
7	121487	GROMMET	1
8	109193	ELBOW, tube; 10-32 x 5/32 in. (4 mm) OD tube	3
9	100139	PLUG, pipe; 1/8 -27 npt	2
11	598095	TUBE; 5/32 in. (4 mm) OD; 15 ft (4.6 m); nylon; see page 19	1
12	15T635	PANEL	1
13	590332	TUBE; 1/4 in. (6 mm) OD; 5 ft (1.5 m); see page 19	1
14	119162	CONNECTOR, plug, 6 position	1
15	256172	BOARD, circuit	1
16	112324	SCREW, machine, pan-hd, 4-40 x 1/4 in. (6 mm)	6
17	15U927	BRACKET, color change; see page 19	1
18	C06061	MUFFLER	1
19	24N345	HOSE; ptfе; 1/4 npsm(fbe); 1/4 in. (6 mm) ID; 1.5 ft (0.46 m); see page 19	1
20	C19798	SCREW, cap, socket-hd; 1/4-20 x 3/8 in. (10 mm); see page 19	4
26	116343	SCREW, ground	1
29	115671	FITTING, connector; 1/8 npt(m) x 1/4 in. (6 mm) OD tube	1
30	15T752	COVER, color change control; see page 19	1
31	123690	FUSE; 125 mA	1
32	n/a	SCREW, machine, serrated hex-head (see page 19)	4

Parts labeled n/a are not available separately.

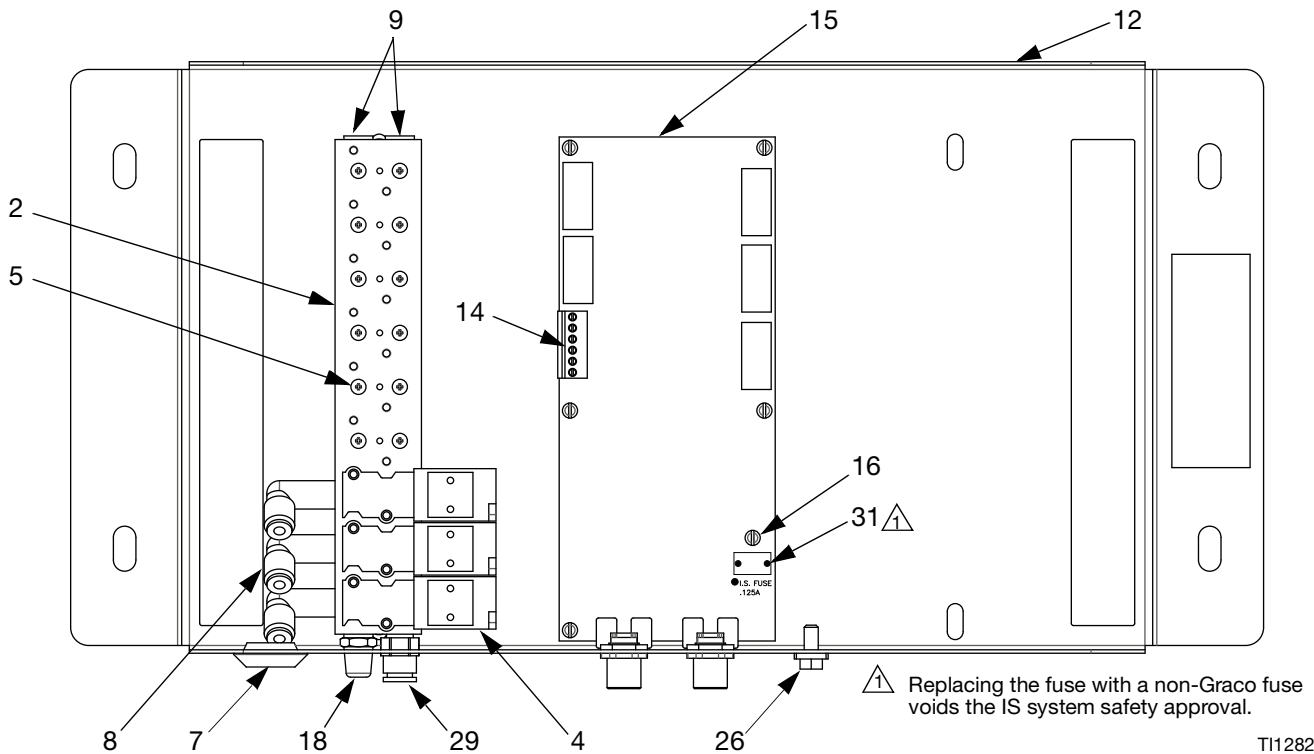

TI12824a

278095 1 Catalyst/1 Flush Control Module (0 Color)

Ref. No.	Part No.	Description	Qty
2	15T636	MANIFOLD, color change control	1
3	103833	SCREW, machine, pan hd; 10-32 x 3/8 in. (10 mm) (behind panel 12 and manifold 2)	2
4	121324	VALVE, solenoid	2
5	121628	SCREW, self-sealing; 4-40 x 1/4 in. (6 mm)	14
7	121487	GROMMET	1
8	109193	ELBOW, tube; 10-32 x 5/32 in. (4 mm) OD tube	2
9	100139	PLUG, pipe; 1/8 -27 npt	2
11	598095	TUBE; 5/32 in. (4 mm) OD; 15 ft (4.6 m); nylon; see page 19	1
12	15T635	PANEL	1
13	590332	TUBE; 1/4 in. (6 mm) OD; 5 ft (1.5 m); see page 19	1
14	119162	CONNECTOR, plug, 6 position	1
15	256172	BOARD, circuit	1
16	112324	SCREW, machine, pan-hd, 4-40 x 1/4 in. (6 mm)	6
17	15U927	BRACKET, color change; see page 19	1
18	C06061	MUFFLER	1
19	24N345	HOSE; ptfе; 1/4 npsm(fbe); 1/4 in. (6 mm) ID; 1.5 ft (0.46 m); see page 19	1
20	C19798	SCREW, cap, socket-hd; 1/4-20 x 3/8 in. (10 mm); see page 19	4
26	116343	SCREW, ground	1
29	115671	FITTING, connector; 1/8 npt(m) x 1/4 in. (6 mm) OD tube	1
30	15T752	COVER, color change control; see page 19	1
31	123690	FUSE; 125 mA	1
32	n/a	SCREW, machine, serrated hex-head (see page 19)	4

Parts labeled n/a are not available separately.

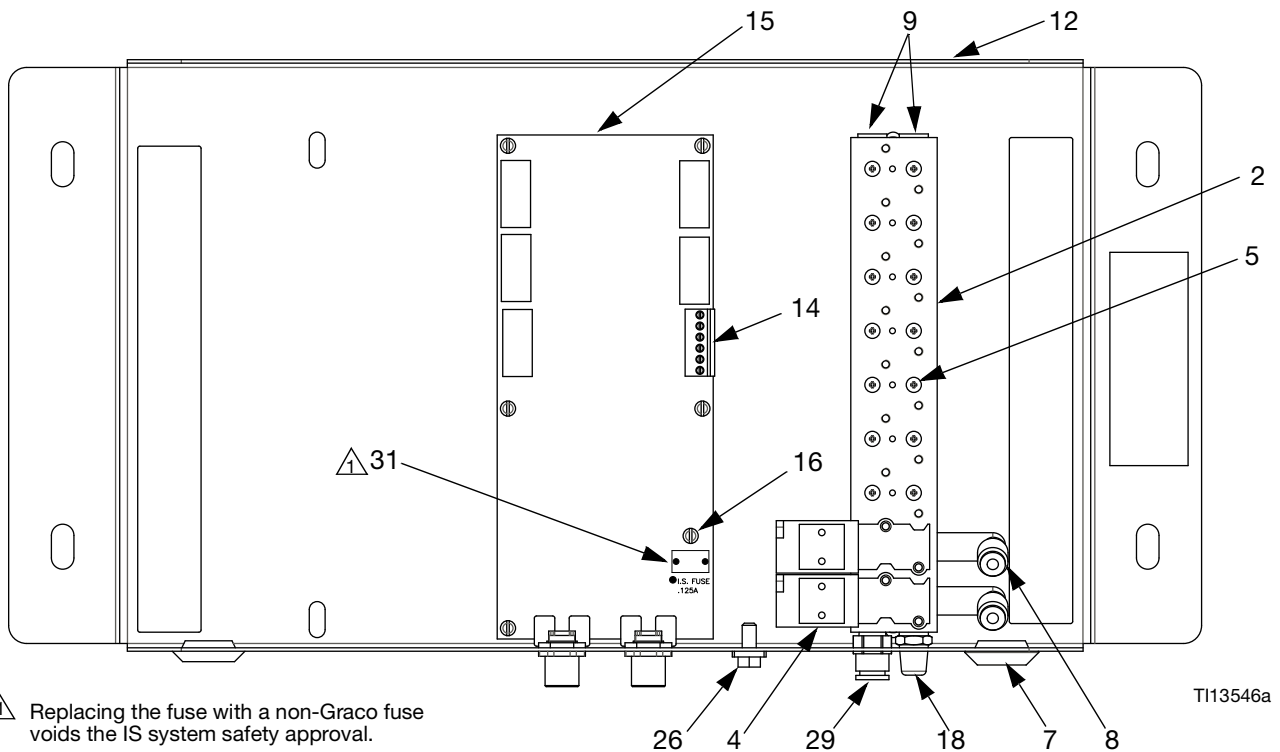

⚠ Replacing the fuse with a non-Graco fuse voids the IS system safety approval.

T113546a

Dimensions

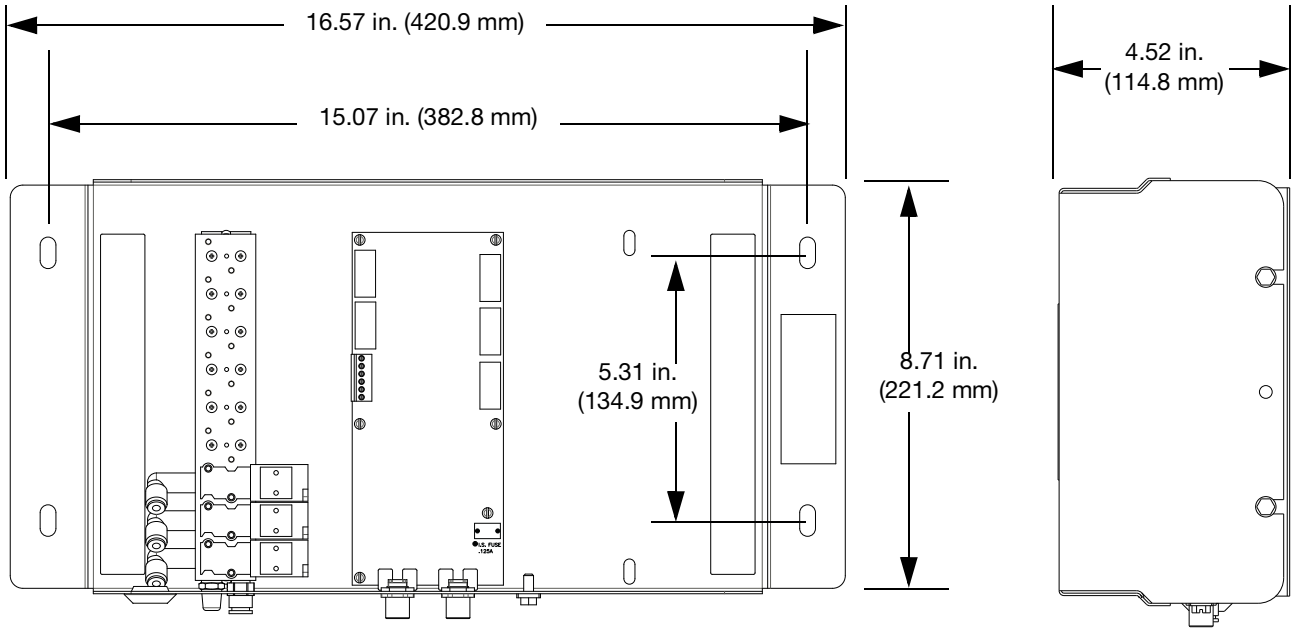

TI12824a

TI12825b

Technical Data

Air Specifications

Maximum Air Input Pressure 100 psi (0.7 MPa, 7.0 bar)
 Minimum Air Input Pressure. 75 psi (0.52 MPa, 5.2 bar)

Fluid Specifications

Maximum Fluid Working Pressure Low Pressure Valve Stacks: 300 psi (2.1 MPa, 21 bar)
 High Pressure Valve Stacks: 3000 psi (21 MPa, 210 bar)
 Fluid Wetted Parts 303 SST, Tungsten Carbide, ptfе
 Hose: ptfе
 Color Change Valves: see manual 312782

Weight see table below

Control Module	Weight, lb (kg)
2 color	6.10 (2.77)
4 color	6.50 (2.95)
7 color	7.10 (3.22)
12 color	7.95 (3.61)
2 color/2 catalyst	6.55 (2.97)
4 color/2 catalyst	6.95 (3.15)
4 color/4 catalyst	7.35 (3.33)

Control Module	Weight, lb (kg)
7 color/2 catalyst	7.55 (3.42)
7 color/4 catalyst	7.95 (3.61)
12 color/2 catalyst	8.30 (3.76)
12 color/4 catalyst	8.70 (3.95)

Graco Standard Warranty

Graco warrants all equipment referenced in this document which is manufactured by Graco and bearing its name to be free from defects in material and workmanship on the date of sale to the original purchaser for use. With the exception of any special, extended, or limited warranty published by Graco, Graco will, for a period of twelve months from the date of sale, repair or replace any part of the equipment determined by Graco to be defective. This warranty applies only when the equipment is installed, operated and maintained in accordance with Graco's written recommendations.

This warranty does not cover, and Graco shall not be liable for general wear and tear, or any malfunction, damage or wear caused by faulty installation, misapplication, abrasion, corrosion, inadequate or improper maintenance, negligence, accident, tampering, or substitution of non-Graco component parts. Nor shall Graco be liable for malfunction, damage or wear caused by the incompatibility of Graco equipment with structures, accessories, equipment or materials not supplied by Graco, or the improper design, manufacture, installation, operation or maintenance of structures, accessories, equipment or materials not supplied by Graco.

This warranty is conditioned upon the prepaid return of the equipment claimed to be defective to an authorized Graco distributor for verification of the claimed defect. If the claimed defect is verified, Graco will repair or replace free of charge any defective parts. The equipment will be returned to the original purchaser transportation prepaid. If inspection of the equipment does not disclose any defect in material or workmanship, repairs will be made at a reasonable charge, which charges may include the costs of parts, labor, and transportation.

THIS WARRANTY IS EXCLUSIVE, AND IS IN LIEU OF ANY OTHER WARRANTIES, EXPRESS OR IMPLIED, INCLUDING BUT NOT LIMITED TO WARRANTY OF MERCHANTABILITY OR WARRANTY OF FITNESS FOR A PARTICULAR PURPOSE.

Graco's sole obligation and buyer's sole remedy for any breach of warranty shall be as set forth above. The buyer agrees that no other remedy (including, but not limited to, incidental or consequential damages for lost profits, lost sales, injury to person or property, or any other incidental or consequential loss) shall be available. Any action for breach of warranty must be brought within two (2) years of the date of sale.

GRACO MAKES NO WARRANTY, AND DISCLAIMS ALL IMPLIED WARRANTIES OF MERCHANTABILITY AND FITNESS FOR A PARTICULAR PURPOSE, IN CONNECTION WITH ACCESSORIES, EQUIPMENT, MATERIALS OR COMPONENTS SOLD BUT NOT MANUFACTURED BY GRACO. These items sold, but not manufactured by Graco (such as electric motors, switches, hose, etc.), are subject to the warranty, if any, of their manufacturer. Graco will provide purchaser with reasonable assistance in making any claim for breach of these warranties.

In no event will Graco be liable for indirect, incidental, special or consequential damages resulting from Graco supplying equipment hereunder, or the furnishing, performance, or use of any products or other goods sold hereto, whether due to a breach of contract, breach of warranty, the negligence of Graco, or otherwise.

FOR GRACO CANADA CUSTOMERS

The Parties acknowledge that they have required that the present document, as well as all documents, notices and legal proceedings entered into, given or instituted pursuant hereto or relating directly or indirectly hereto, be drawn up in English. Les parties reconnaissent avoir convenu que la rédaction du présente document sera en Anglais, ainsi que tous documents, avis et procédures judiciaires exécutés, donnés ou intentés, à la suite de ou en rapport, directement ou indirectement, avec les procédures concernées.

Graco Information

For the latest information about Graco products, visit www.graco.com.

TO PLACE AN ORDER, contact your Graco distributor or call to identify the nearest distributor.

Toll Free Phone Number: 1-800-328-0211

*All written and visual data contained in this document reflects the latest product information available at the time of publication.
Graco reserves the right to make changes at any time without notice.*

Original instructions. This manual contains English. MM 312787

Graco Headquarters: Minneapolis

International Offices: Belgium, China, Japan, Korea

GRACO INC. AND SUBSIDIARIES • P.O. BOX 1441 • MINNEAPOLIS, MN 55440-1441 • USA

Copyright 2008, Graco Inc. All Graco manufacturing locations are registered to ISO 9001.

www.graco.com

Revision J, November 2024