



## Color/Catalyst Dispense Valves

332454E  
EN

---

To dispense color, catalyst, solvent, and acid in a ProMix® PD2K Electronic Proportioning System with the color change option.  
For professional use only.



### Important Safety Instructions

Read all warnings and instructions in your color change kit manual and PD2K proportioner manual. Save these instructions.

*See page 3 for model part numbers and maximum working pressures.*

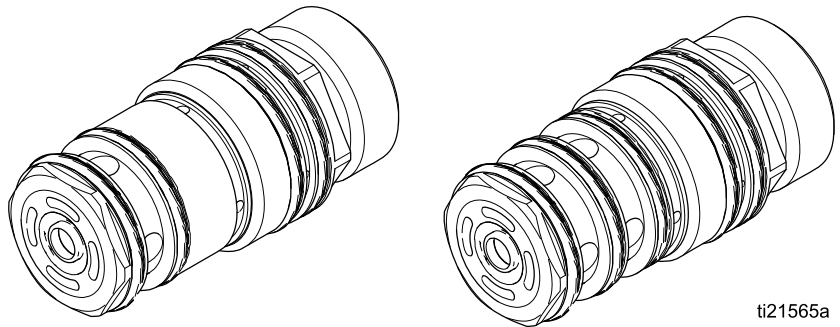

ti21565a

# Contents

Related Manuals .....	2	Parts .....	5
Models .....	2	Low Pressure Valve Parts .....	5
Repair .....	3	High Pressure Valve Parts .....	6
Disassembly .....	3	O-Ring Size Guide .....	7
Reassembly .....	4	Technical Data .....	9

## Related Manuals

Manual No.	Description
3A2800	PD2K Proportioner Repair-Parts Manual, Manual Systems
332457	PD2K Proportioner Installation Manual, Manual Systems
332562	PD2K Proportioner Operation Manual, Manual Systems
3A2801	Mix Manifold Instructions-Parts Manual

Manual No.	Description
332339	Pump Repair-Parts Manual
332455	Color Change Kits Instructions-Parts Manual
332456	3rd and 4th Pump Kits Instructions-Parts Manual

## Models

Kit No.	Series	Kit Description	Maximum Air Working Pressure	Maximum Fluid Working Pressure
<b>Low Pressure Valve Kits</b>				
24T441	A	non-circulating	100 psi (0.7 MPa, 7.0 bar)	300 psi (2.068 MPa, 20.68 bar)
24T442	A	circulating	100 psi (0.7 MPa, 7.0 bar)	300 psi (2.068 MPa, 20.68 bar)
26A362	A	non-circulating, solvent compatible	100 psi (0.7 MPa, 7.0 bar)	300 psi (2.068 MPa, 20.68 bar)
<b>High Pressure Valve Kits</b>				
24T581	A	non-circulating	100 psi (0.7 MPa, 7.0 bar)	1500 psi (10.34 MPa, 103.4 bar)
24T582	A	circulating	100 psi (0.7 MPa, 7.0 bar)	1500 psi (10.34 MPa, 103.4 bar)
25A289	A	non-circulating, solvent compatible	100 psi (0.7 MPa, 7.0 bar)	1500 psi (10.34 MPa, 103.4 bar)
24T583	A	non-circulating, acid compatible	100 psi (0.7 MPa, 7.0 bar)	1500 psi (10.34 MPa, 103.4 bar)

# Repair

## Disassembly

1. Relieve the pressure as described in your PD2K operation manual.
2. Remove the valve from the manifold as described in your color change kit manual. Inspect the 111450 or 106152 manifold o-ring.
3. Hold the seat body (2) steady with a box wrench. Use a wrench on the flats of the piston body (5) to unscrew it from the seat body.
4. Remove the spring (11).
 

**NOTE:** High pressure valves have two springs (11 and 21).
5. Remove the two outer o-rings (16) and the inner o-ring (20) from the piston body (5).
6. Using the 24U236 tool (111, supplied with the valve manifold kit) or tool kit 25D980, unscrew the valve seat (1) from the seat body (2).
7. Unscrew the ball (3) from the shaft (4), using a wrench on the flats of the ball.
8. Slide the piston and shaft assembly (4) out of the seat housing (2). Remove the piston o-ring (18).
9. Using the 24U236 tool (111) or tool kit 25D980, unscrew the backup seal and washer (9) from the seat body (2).
10. Remove the o-ring (19) from the seat body (2).
11. Using a small screwdriver, push the seal and retainer (7) out of the seat body (2) from the opposite end. Remove the o-ring (14) from the seat body (2).
12. Remove the o-rings (15) from the seat body (2).
 

**NOTE:** Circulating valves have three o-rings (15); non-circulating valves have two.

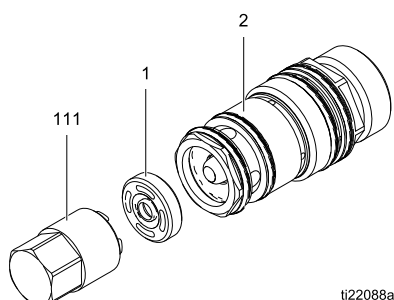

ti22088a

Figure 1 Remove Valve Seat

## Reassembly

1. Install the o-rings (15) on the seat body (2).  
**NOTE:** Circulating valves have three o-rings (15); non-circulating valves have two.
2. Lubricate the o-ring (14) and install it in the seat body (2).
3. Lubricate the u-cup in the seal and retainer assembly (7). Install in the seat body (2) with the lips of the u-cup facing into the seat body.
4. Install the o-ring (19) in the seat body (2).
5. Using the 24U236 tool (111) or tool kit 25D980, screw the backup seal and washer (9) into the seat body (2). Torque to 20 in-lb (2.2 N•m).
6. Install the piston o-ring (18) on the piston.
7. Lubricate the piston shaft (4) and slide it into the seat body (2).
8. Apply medium strength (blue) thread sealant to the ball (3). Using a wrench on the flats of the ball, screw it onto the shaft (4). Torque to 5 in-lb (0.5 N•m) **maximum**.
9. Lubricate the ball and inside surface of the seat body (2). Using the 24U236 tool (111) or tool kit 25D980, screw the valve seat (1) into the seat body (2). Torque to 20 in-lb (2.2 N•m).
10. Lubricate the o-ring (20) and install it in the piston body (5).
11. Install the o-rings (16) on the piston body (5).
12. Lubricate the inside of the piston body (5) and the piston o-ring (18).
13. Install the piston spring (11). On high pressure valves only, install the second piston spring (21).
14. Screw the seat body (2) into the piston body (5). Torque to 5 in-lb (0.5 N•m) **maximum**.
15. Lubricate the outer o-rings (15, 16).
16. Slide the assembled valve into the manifold, with the seat body (2) facing into the manifold.
17. Return the valve to service.

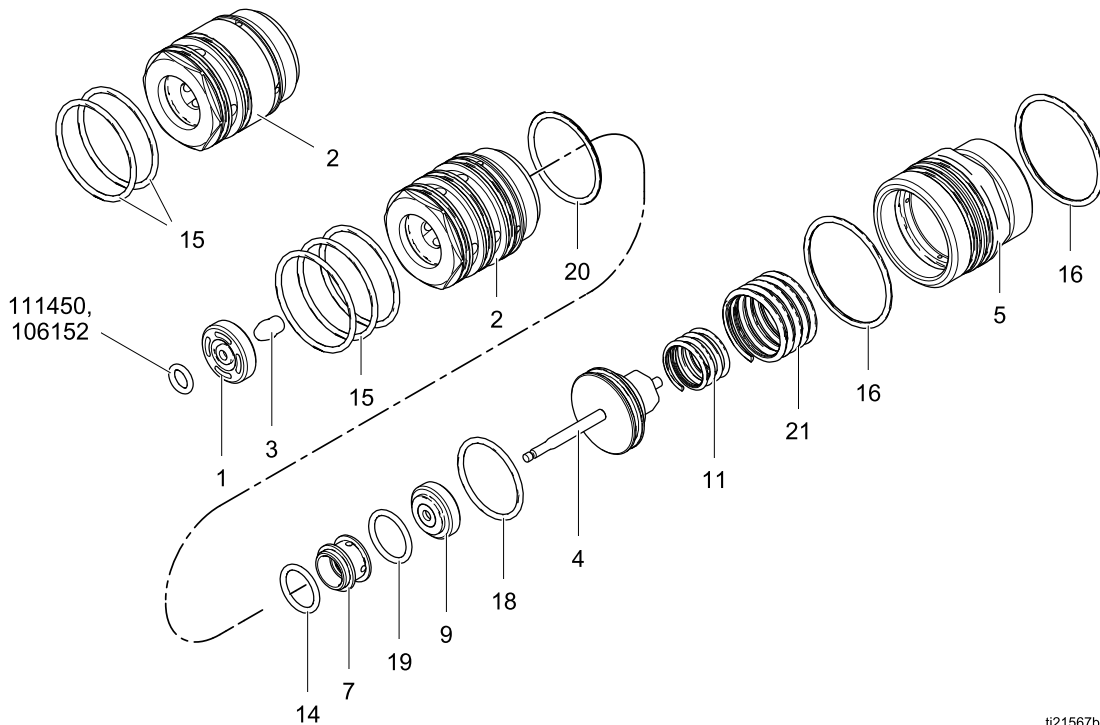

ti21567b

Figure 2 Valve Assembly (High Pressure Circulating Valve Shown)

# Parts

## Low Pressure Valve Parts

Part No. 24T442 Low Pressure Circulating Valve (shown)

Part No. 24T441 Low Pressure Non-Circulating Valve (see detail at upper left)

Part No. 26A362 Low Pressure Non-Circulating Solvent Compatible Valve (see detail at upper left)

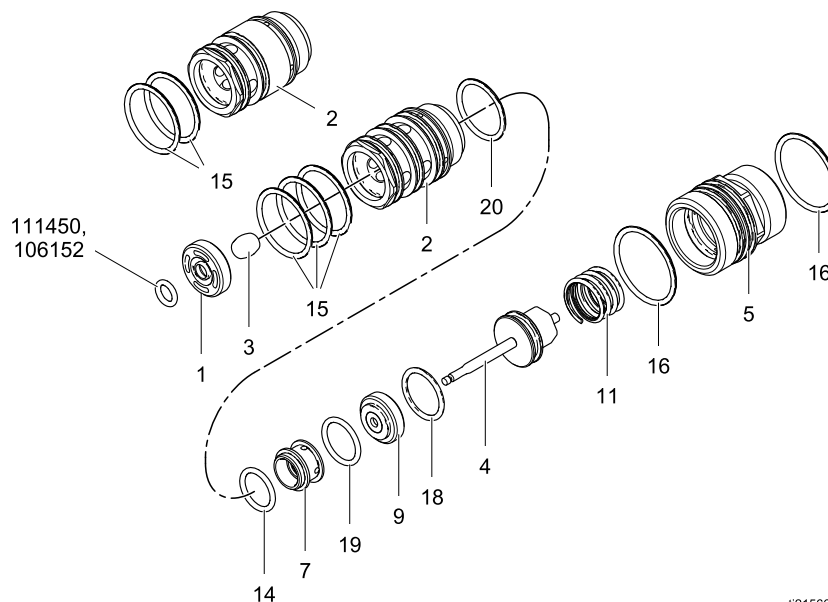

ti21566b

Ref. No.	Part No.	Description	Qty
1	16N244	SEAT, valve; PEEK	1
2	16N245	BODY, seat, circulating; PEEK; 24T442 only	1
	16N275	BODY, seat, non-circulating; PEEK; 24T441 and 26A362 only	1
3	16N247	BALL, valve; stainless steel	1
4	24T530	ASSEMBLY, piston and shaft; stainless steel, aluminum	1
5	16N252	BODY, piston; aluminum, clear; 24T441 only	1
	17Z249	BODY, piston; aluminum, black; 24T442 only	1
	17Z249	BODY, piston; aluminum, blue; 26A362 only	1
7	24T533	SEAL AND RETAINER; UHMWPE and PEEK	1
9	24T534	BACKUP SEAL AND WASHER; UHMWPE and aluminum	1
11	16W502	SPRING, piston	1
14*	113746	O-RING; chemically resistant	1
14+	110084	O-RING; FFKM; 26A362 only	1
15*	117559	O-RING; chemically resistant; 24T442 only	3
		O-RING; chemically resistant; 24T441 only	2
15+	128530	O-RING; FFKM; 26A362 only	2
16*+	121370	O-RING; chemically resistant	2
18*+	116768	O-RING; chemically resistant	1
19*+	117517	O-RING; chemically resistant	1
20*+	16D530	O-RING; chemically resistant	1

\* Parts included in O-ring Kit 24T847 (purchase separately). Kit includes 3 of item 15, and also includes a manifold o-ring 111450. See [O-Ring Kits for Low Pressure Valves, page 7](#).

+ Parts included in O-ring Kit 26A363 (purchase separately). Kit includes 3 of item 15, and also includes a manifold o-ring 106152. See [O-Ring Kits for Low Pressure Valves, page 7](#).

## High Pressure Valve Parts

Part No. 24T582 High Pressure Circulating Valve (shown)

Part No. 24T581 High Pressure Non-Circulating Valve (see detail at upper left)

Part No. 24T583 High Pressure Non-Circulating Acid Compatible Valve (see detail at upper left)

Part No. 25A289 High Pressure Non-Circulating Solvent Compatible Valve (see detail at upper left)

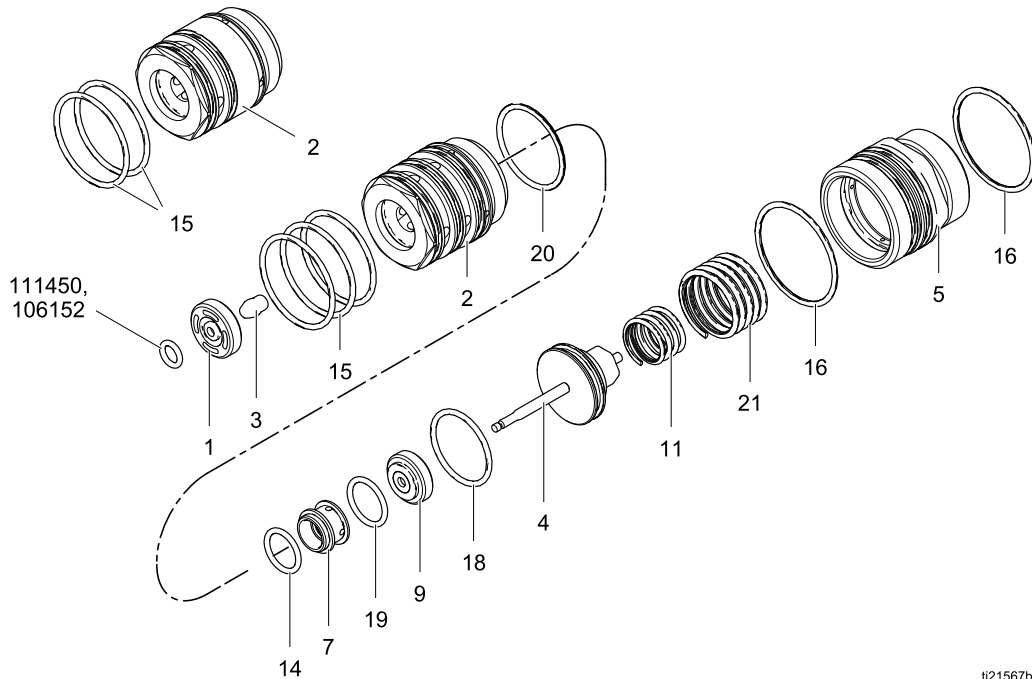

ti21567b

Ref. No.	Part No.	Description	Qty
1	16W158	SEAT, valve; stainless steel	1
2	16N266	BODY, seat, circulating; stainless steel; 24T582 only	1
	16N276	BODY, seat, non-circulating; stainless steel; 24T581, 24T583, and 25A289 only	1
3	24T205	BALL, valve; stainless steel; 24T583 only	1
	24T204	BALL, valve; carbide; 24T581, 24T582, and 25A289 only	1
4	24T735	ASSEMBLY, piston and shaft; stainless steel, aluminum	1
5	16N267	BODY, piston; aluminum	1
7	24T533	SEAL AND RETAINER; UHMWPE and PEEK	1
9	24T534	BACKUP SEAL AND WASHER; UHMWPE and aluminum	1
11	16N254	SPRING, piston, small	1
14*	113746	O-RING; chemically resistant; 25T581 and 25T582 only	1
14+	110084	O-RING; FFKM; 24T583 and 25A289 only	1
15*	16N901	O-RING; chemically resistant; 24T582 only	3
		O-RING; chemically resistant; 24T581 only	2
15+	17R987	O-RING; FFKM; 24T583 and 25A289 only	2
16*+	122134	O-RING; chemically resistant	2
18*+	16V699	O-RING; chemically resistant	1
19*+	117517	O-RING; chemically resistant	1
20*+	16D531	O-RING; chemically resistant	1
21	16N270	SPRING, piston, large	1

\* Parts included in O-ring Kit 24T848 (purchase separately). Kit includes 3 of item 15, and also includes a manifold o-ring 111450. See [O-Ring Kits for High Pressure Valves, page 8](#).

\* Parts included in O-ring Kit 24Y671 (purchase separately). Kit includes 3 of item 15, and also includes a manifold o-ring 106152. See [O-Ring Kits for High Pressure Valves, page 8](#).

## O-Ring Size Guide

The following illustrations show the valve o-rings at actual size. See the **Parts** drawings for locations of the o-rings.

**TIP:** Some o-rings are close in size. Stack on a bench to differentiate.

### O-Ring Kits for Low Pressure Valves

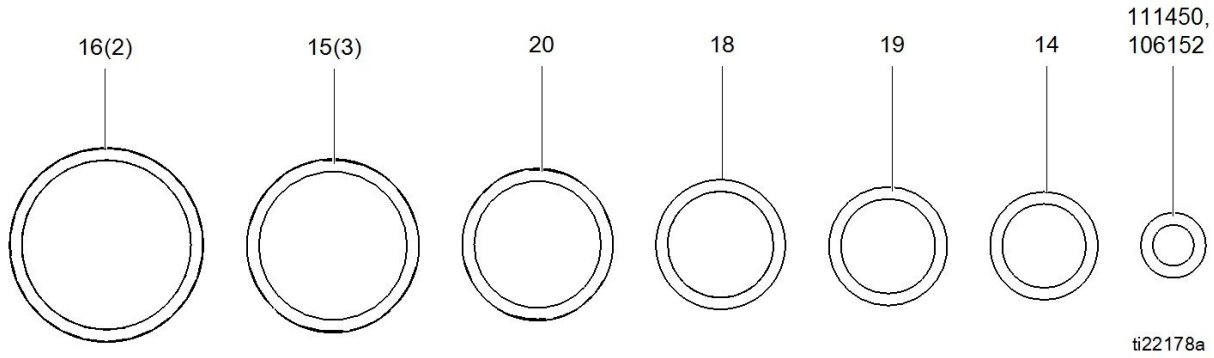
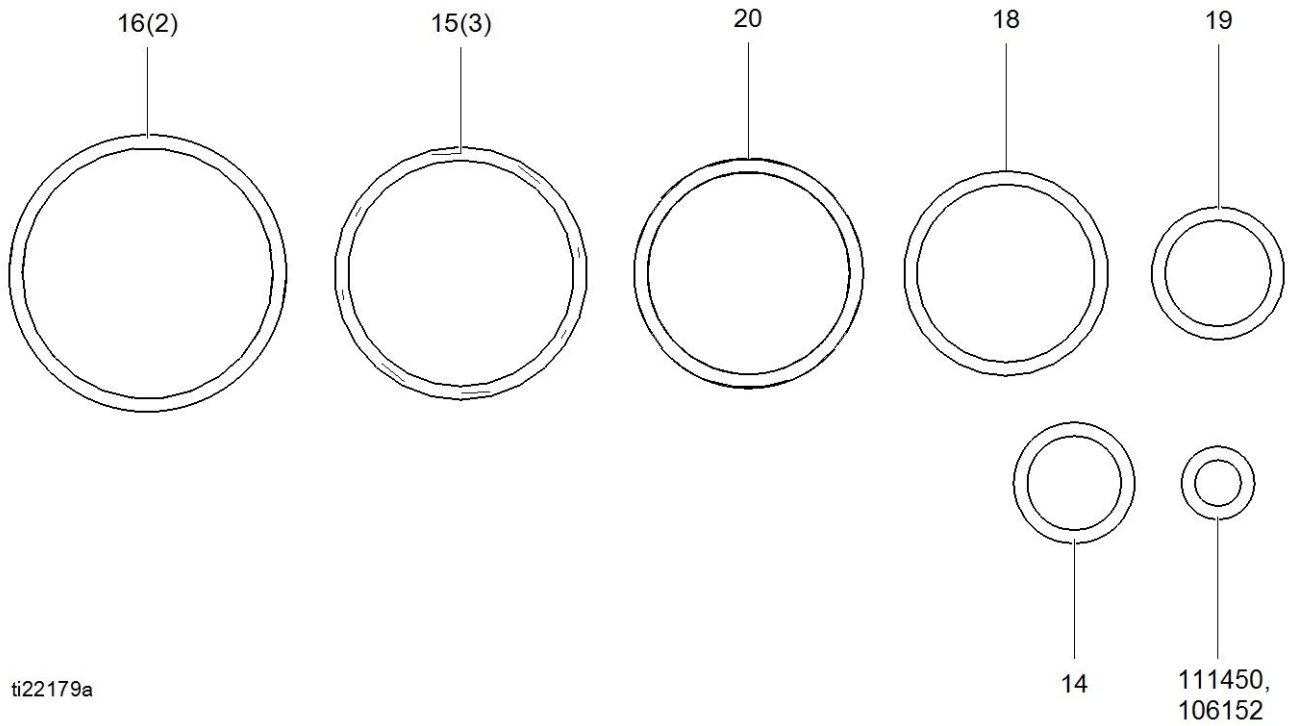

Figure 3 Kit 24T847 and Kit 26A363 O-Ring Sizes

Ref. No.	Part No.		Nominal Size	OD, in. (mm)	Qty
	Kit 24T847	Kit 26A363 (solvent compatible)			
---	111450	106152	010	0.4 (10)	1
14	113746	110084	014	0.6 (16)	1
15	117559	128530	020	1 (25)	3
16	121370	121370	022	1.1 (29)	2
18	116768	116768	016	0.75 (19)	1
19	117517	117517	015	0.7 (18)	1
20	16D530	16D530	018	0.9 (22)	1

O-Ring Kits for High Pressure Valves



ti22179a

Figure 4 Kit 24T848 and Kit 24Y671 O-Ring Sizes

Ref. No.	Part No.		Nominal Size	OD, in. (mm)	Qty
	Kit 24T848	Kit 24Y671 (solvent or acid compatible)			
---	111450	106152	010	0.4 (10)	1
14	113746	110084	014	0.6 (16)	1
15	16N901	17R987	025	1.3 (33)	3
16	122134	122134	027	1.4 (37)	2
18	16V699	16V699	021	1.06 (27)	1
19	117517	117517	015	0.7 (18)	1
20	16D531	16D531	023	1.2 (30)	1



# Technical Data

Color Change Kits	U.S.	Metric
Maximum fluid working pressure:		
Low pressure valves	300 psi	2.1 MPa, 21 bar
High pressure valves	1500 psi	10.5 MPa, 105 bar
Maximum working air pressure:	100 psi	0.7 MPa, 7.0 bar
Air supply:	85–100 psi	0.6–0.7 MPa, 6.0–7.0 bar
Viscosity range of fluid:	20–5000 centipoise	
Weight		
24T441 and 26A362 low pressure non-circulating valve	55 g	
24T442 low pressure circulating valve	53 g	
24T581, 24T583, and 25A289 high pressure non-circulating valves	248 g	
24T582 high pressure circulating valve	227 g	
Wetted parts:		
24T441 and 24T442 low pressure valves	PEEK, 301 and 17–4 stainless steel, UHMWPE, chemically resistant o-rings	
26A362 low pressure solvent compatible valve	PEEK, 301 and 17–4 stainless steel, UHMWPE, FFKM (Perfluoroelastomer) o-rings	
24T581 and 24T582 high pressure valves	PEEK, 301 and 17–4 stainless steel, UHMWPE, chemically resistant o-rings, carbide	
25A289 high pressure solvent compatible valve	PEEK, 301 and 17–4 stainless steel, UHMWPE, FFKM (Perfluoroelastomer) o-rings, carbide	
24T583 high pressure acid compatible valve	PEEK, 301, 316, and 17–4 stainless steel, UHMWPE, FFKM (Perfluoroelastomer) o-rings	

# Graco Standard Warranty

Graco warrants all equipment referenced in this document which is manufactured by Graco and bearing its name to be free from defects in material and workmanship on the date of sale to the original purchaser for use. With the exception of any special, extended, or limited warranty published by Graco, Graco will, for a period of twelve months from the date of sale, repair or replace any part of the equipment determined by Graco to be defective. This warranty applies only when the equipment is installed, operated and maintained in accordance with Graco's written recommendations.

This warranty does not cover, and Graco shall not be liable for general wear and tear, or any malfunction, damage or wear caused by faulty installation, misapplication, abrasion, corrosion, inadequate or improper maintenance, negligence, accident, tampering, or substitution of non-Graco component parts. Nor shall Graco be liable for malfunction, damage or wear caused by the incompatibility of Graco equipment with structures, accessories, equipment or materials not supplied by Graco, or the improper design, manufacture, installation, operation or maintenance of structures, accessories, equipment or materials not supplied by Graco.

This warranty is conditioned upon the prepaid return of the equipment claimed to be defective to an authorized Graco distributor for verification of the claimed defect. If the claimed defect is verified, Graco will repair or replace free of charge any defective parts. The equipment will be returned to the original purchaser transportation prepaid. If inspection of the equipment does not disclose any defect in material or workmanship, repairs will be made at a reasonable charge, which charges may include the costs of parts, labor, and transportation.

**THIS WARRANTY IS EXCLUSIVE, AND IS IN LIEU OF ANY OTHER WARRANTIES, EXPRESS OR IMPLIED, INCLUDING BUT NOT LIMITED TO WARRANTY OF MERCHANTABILITY OR WARRANTY OF FITNESS FOR A PARTICULAR PURPOSE.**

Graco's sole obligation and buyer's sole remedy for any breach of warranty shall be as set forth above. The buyer agrees that no other remedy (including, but not limited to, incidental or consequential damages for lost profits, lost sales, injury to person or property, or any other incidental or consequential loss) shall be available. Any action for breach of warranty must be brought within two (2) years of the date of sale.

**GRACO MAKES NO WARRANTY, AND DISCLAIMS ALL IMPLIED WARRANTIES OF MERCHANTABILITY AND FITNESS FOR A PARTICULAR PURPOSE, IN CONNECTION WITH ACCESSORIES, EQUIPMENT, MATERIALS OR COMPONENTS SOLD BUT NOT MANUFACTURED BY GRACO.** These items sold, but not manufactured by Graco (such as electric motors, switches, hose, etc.), are subject to the warranty, if any, of their manufacturer. Graco will provide purchaser with reasonable assistance in making any claim for breach of these warranties.

In no event will Graco be liable for indirect, incidental, special or consequential damages resulting from Graco supplying equipment hereunder, or the furnishing, performance, or use of any products or other goods sold hereto, whether due to a breach of contract, breach of warranty, the negligence of Graco, or otherwise.

## FOR GRACO CANADA CUSTOMERS

The Parties acknowledge that they have required that the present document, as well as all documents, notices and legal proceedings entered into, given or instituted pursuant hereto or relating directly or indirectly hereto, be drawn up in English. Les parties reconnaissent avoir convenu que la rédaction du présente document sera en Anglais, ainsi que tous documents, avis et procédures judiciaires exécutés, donnés ou intentés, à la suite de ou en rapport, directement ou indirectement, avec les procédures concernées.

## Graco Information

For the latest information about Graco products, visit [www.graco.com](http://www.graco.com).

**To place an order**, contact your Graco Distributor or call to identify the nearest distributor.

**Phone:** 612-623-6921 **or Toll Free:** 1-800-328-0211 **Fax:** 612-378-3505

All written and visual data contained in this document reflects the latest product information available at the time of publication.

Graco reserves the right to make changes at any time without notice.

For patent information, see [www.graco.com/patents](http://www.graco.com/patents).

Original Instructions. This manual contains English. MM 332454

**Graco Headquarters:** Minneapolis

**International Offices:** Belgium, China, Japan, Korea

**GRACO INC. AND SUBSIDIARIES • P.O. BOX 1441 • MINNEAPOLIS MN 55440-1441 • USA**

**Copyright 2013, Graco Inc. All Graco manufacturing locations are registered to ISO 9001.**

[www.graco.com](http://www.graco.com)  
Revision E, 2019-01