

Fill Valve

333393E

EN

Refill manifold for use with Graco Auto-Fill Shut Off Valve only. For professional use only.

Part No.:

77X542

132230

5000 psi (34.4 MPa, 344.7 bar) Maximum Working Pressure

Part No. 132230: 3000 psi (20.7 MPa, 206.8 bar)



Important Safety Instructions



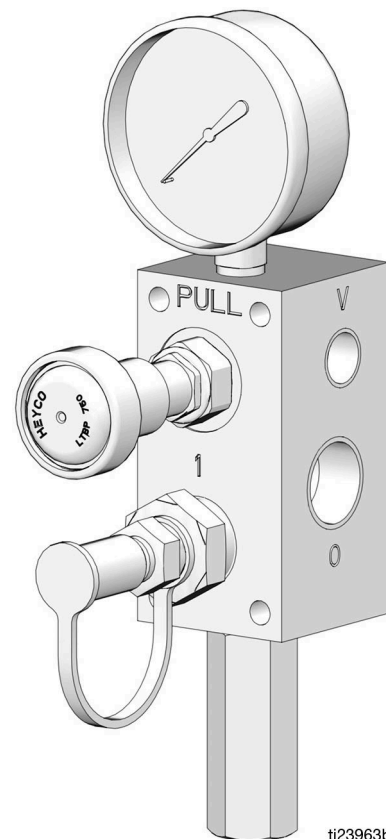



Read all warnings and instructions in this manual and in Electric DynaStar and Auto-Fill Shut Off Valve Instruction manuals. Save all instructions.



ti23963b

Warnings

The following warnings are for the setup, use, grounding, maintenance, and repair of this equipment. The exclamation point symbol alerts you to a general warning and the hazard symbols refer to procedure-specific risks. When these symbols appear in the body of this manual or on warning labels, refer back to these Warnings. Product-specific hazard symbols and warnings not covered in this section may appear throughout the body of this manual where applicable.

 WARNING	
  	<p>SKIN INJECTION HAZARD</p> <p>High-pressure fluid from dispensing device, hose leaks, or ruptured components will pierce skin. This may look like just a cut, but it is a serious injury that can result in amputation. Get immediate surgical treatment.</p> <ul style="list-style-type: none"> • Do not point dispensing device at anyone or at any part of the body. • Do not put your hand over the fluid outlet. • Do not stop or deflect leaks with your hand, body, glove, or rag. • Follow the Pressure Relief Procedure when you stop dispensing and before cleaning, checking, or servicing equipment. • Tighten all fluid connections before operating the equipment. • Check hoses and couplings daily. Replace worn or damaged parts immediately.
 	<p>EQUIPMENT MISUSE HAZARD</p> <p>Misuse can cause death or serious injury.</p> <ul style="list-style-type: none"> • Do not operate the unit when fatigued or under the influence of drugs or alcohol. • Do not exceed the maximum working pressure or temperature rating of the lowest rated system component. See Technical Specifications in all equipment manuals. • Use fluids and solvents that are compatible with equipment wetted parts. See Technical Specifications in all equipment manuals. Read fluid and solvent manufacturer's warnings. For complete information about your material, request MSDS from distributor or retailer. • Do not leave the work area while equipment is energized or under pressure. • Turn off all equipment and follow the Pressure Relief Procedure when equipment is not in use. • Check equipment daily. Repair or replace worn or damaged parts immediately with genuine manufacturer's replacement parts only. • Do not alter or modify equipment. Alterations or modifications may void agency approvals and create safety hazards. • Make sure all equipment is rated and approved for the environment in which you are using it. • Use equipment only for its intended purpose. Call your distributor for information. • Route hoses and cables away from traffic areas, sharp edges, moving parts, and hot surfaces. • Do not kink or over bend hoses or use hoses to pull equipment. • Keep children and animals away from work area. • Comply with all applicable safety regulations.
	<p>PERSONAL PROTECTIVE EQUIPMENT</p> <p>Wear appropriate protective equipment when in the work area to help prevent serious injury, including eye injury, hearing loss, inhalation of toxic fumes, and burns. This protective equipment includes but is not limited to:</p> <ul style="list-style-type: none"> • Protective eye wear, and hearing protection. • Respirators, protective clothing, and gloves as recommended by the fluid and solvent manufacturers.

Installation

Typical Installation

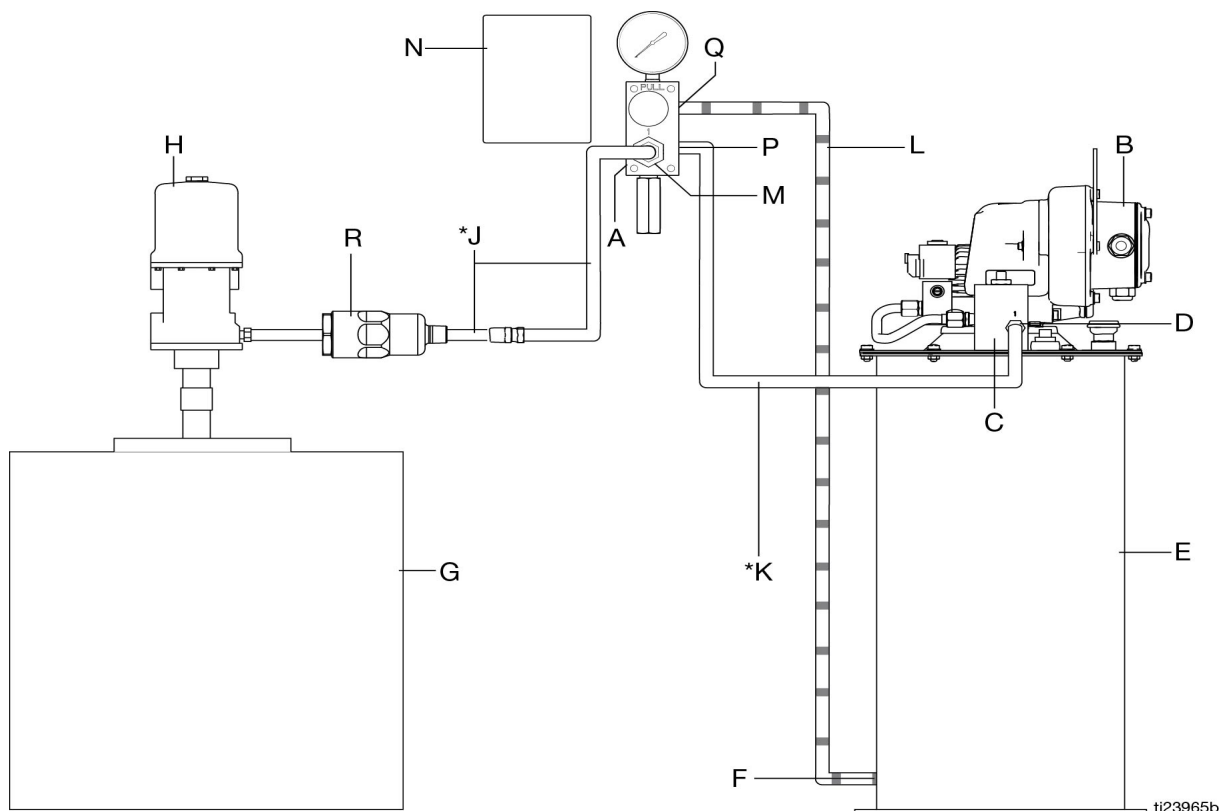

- | | | | |
|---|---|---|--|
| A | Fill Valve | K | Supply Hose (user supplied)* |
| B | Dyna-Star Pump | L | Drain Hose |
| C | Auto-Fill Shut Off Valve | M | Fill Stud |
| D | Auto-Fill Inlet | N | Operating Instructions Label |
| E | Reservoir | P | Fill Valve Outlet |
| F | Reservoir Port (vent line) | Q | Fill Valve Vent Port |
| G | Remote Filling Station Reservoir | R | Filter (recommended if grease/environment is contaminated) |
| H | Remote Filling Station Pump (pneumatic) | | |
| J | Supply Hose (user supplied)* | | |

*Supply hoses must be rated for a minimum 5000 psi (34.4 MPa, 344.7 bar) pressure. See Operation, page 5 for additional information.

Fill Valve Component Identification

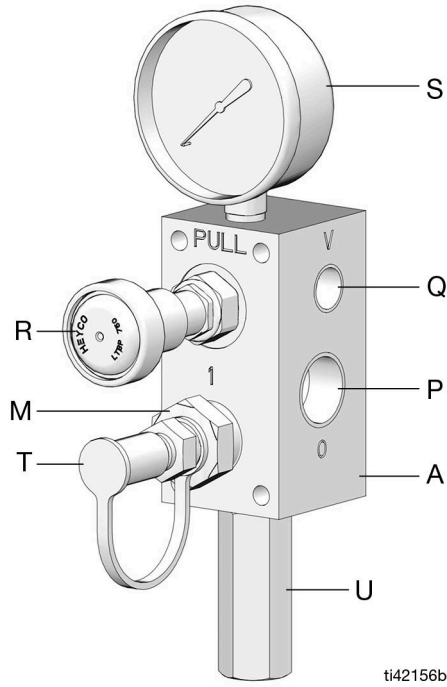

FIG. 1

- A Fill Valve
- M Fill Stud
- N Instruction Label (not shown, see Typical Installation, page 3)
- P Fill Valve Outlet
- Q Fill Valve Vent Port
- R Pressure Relief Plunger
- S Pressure Gauge
- T Dust Cover
- U Pressure Relief Valve

Installation

The reference letters used in the following instructions refer to the Typical Installation diagram provided on page 3 and the Component Identification illustration (FIG. 1).





1. Select the installation location. Be sure the installation location chosen is clean, flat and easily accessible
2. Orient the Fill Valve (A) as shown in FIG. 1. When the Fill Valve is correctly oriented the Pressure Gauge (S) will be located on the top of the Fill Valve block and the Pressure Relief Valve (U) will be located on the bottom of the block.

<p>To reduce the risk of serious injury from skin injection, the Fill Valve (A) must be installed with the pressure gauge (S) located on the top of the Fill Valve and the pressure relief valve (U) pointing down as shown in FIG. 1.</p>						

3. Use mounting dimensions provided on page 7 of this manual to drill 4 mounting holes in the installation surface
4. Secure Fill Valve (A) to installation surface using 4 1/4 inch bolts.
5. Select a convenient location close to the valve to adhere the Operating Instructions label (N) (included with your valve).

NOTE: Clean the surface prior to installing the label to remove contaminants such as dust, dirt, grease and oil residue which could weaken or prevent adhesion.
6. Connect Supply Hose (K) between the Auto-Fill Shut Off Valve (C) and Fill Valve Outlet (P) port marked with an "O".
7. Connect a Drain Hose (L) between the Fill Valve Vent Outlet (Q) port marked with a "V" and the Reservoir Port (E/F).

Operation

						
<p>The remote filling station pump stalls (dead-heads) when the reservoir is full, causing the supply system pressure to rise to the maximum output pressure of the filling station pump. To help prevent equipment damage or serious injury caused by pressurized fluid, such as skin injection or injury from splashing fluid, always use a remote filling station pump with a maximum output pressure of 5000 psi (34.4 MPa, 344.7 bar) and use supply hoses with a minimum pressure rating of 5000 psi (34.4 MPa, 344.7 bar).</p>						

The reference letters used in the following instructions refer to the Typical Installation diagram provided on page 3 and Component Identification on page 4.

1. Pull out and hold the Pressure Relief Plunger (R) long enough to relieve line pressure between Fill Valve (A) and Auto-Fill Shut Off Valve (C).
2. Verify that the Pressure Relief Plunger (R) is seated and returned to the original position.

NOTICE

Failure to reset the Pressure Relief Plunger (R) could lead to equipment damage.

3. Verify that the Auto-Fill Shut Off pin is down, indicating it is reset (FIG. 2). See the Auto-Fill Shut Off instruction manual.

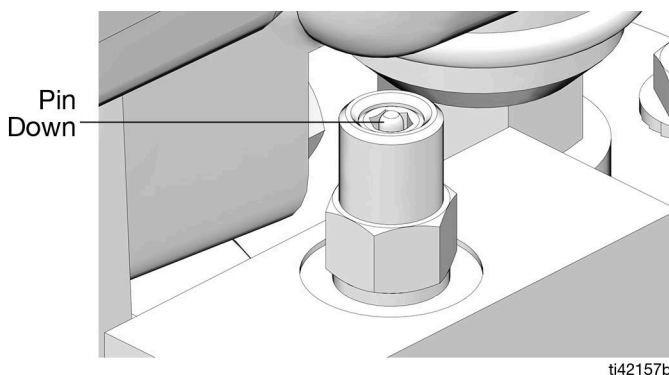

FIG. 2

4. Remove Dust Cover (T) from Fill Coupler (M).
5. Connect Supply Hose (J) between the Remote Filling Stations Pump (H) and Fill Coupler (M) port marked with an "I".
6. Start Remote Filling Station Pump (H).

7. When Reservoir (E) is filled:
 - the Remote Filling Station Pump (H) stalls (dead-heads),
 - the Auto-Fill Shut Off pin pops up as shown in FIG. 3,
 - the gauge pressure rises to the fill pump's set pressure.

NOTE: If the pump does not stall (dead-head) there is a leak in the system.

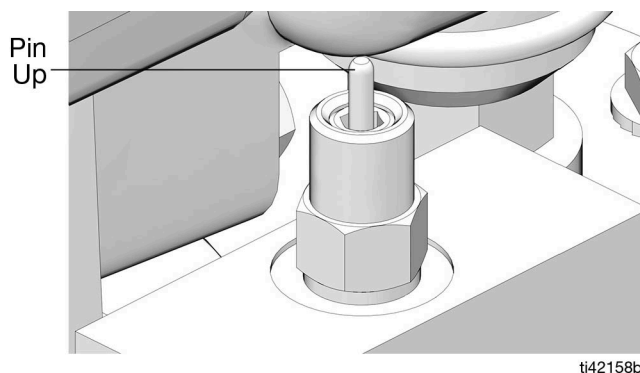

FIG. 3

8. Turn off the Remote Filling Station Pump (H).
9. Pull out and hold the Pressure Relief Plunger (R) long enough to relieve line pressure between Fill Valve (A) and Auto-Fill Shut Off Valve (C) and between Remote Filling Station Pump (H) and Fill Valve (A).
10. Verify that the Pressure Relief Plunger (R) is seated and returned to the original position.

NOTICE

Failure to reset the Pressure Relief Plunger (R) could lead to equipment damage.

NOTE: The length of time it takes to vent varies depending on the system design and installation. In some installations it may be necessary to repeat Step 9 to ensure pressure is relieved.

11. Disconnect Supply Hose (J) at Fill Coupler (M).
12. Replace Dust Cover (T) over Fill Coupler (M).

Troubleshooting

Pressure Relief Procedure



Follow the Pressure Relief Procedure whenever you see this symbol.



This equipment stays pressurized until pressure is manually relieved. To help prevent serious injury from pressurized fluid, such as skin injection, splashing fluid and moving parts, follow the Pressure Relief Procedure when you stop dispensing and before cleaning, checking, or servicing the equipment.

To relieve pressure in the system, use two wrenches working in opposite directions on valve outlet fitting to **slowly loosen fitting only** until fitting is loose and no more lubricant or air is leaking from fitting as shown in FIG. 4.

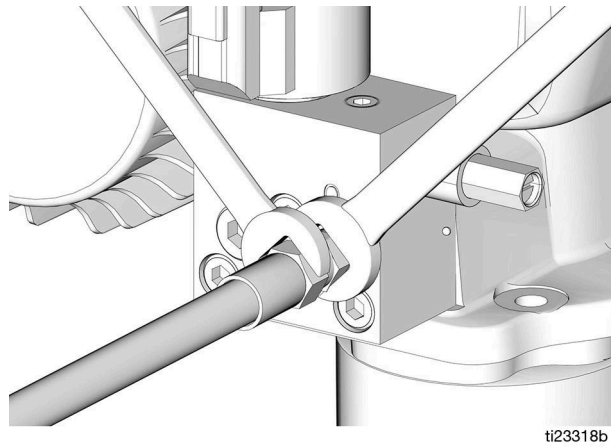

FIG. 4

Problem	Cause	Solution
Refill pump slows down or stalls and no output at the fill valve.	Auto-Fill Shut Off Valve has not reset	Be sure to relieve pressure by pulling the Pressure Relief Plunger (R) (see Component Identification, page 4).
		Make sure Auto-Fill Shut Off valve pin is down. See FIG. 2, page 5 and/or Auto-Fill Shut Off Valve manual.

Technical Specifications

Fill Valve		
	US	Metric
77X542		
Maximum fluid working pressure	5000 psi	34.4 MPa, 344.7 bar
Relief value	5000 psi \pm 10%	34.4 MPa, 344.7 bar \pm 10%
132230		
Maximum fluid working pressure	3000 psi	20.7 MPa, 206.8 bar
Relief value	3000 psi \pm 10%	20.7 MPa, 206.8 bar \pm 10%
Maximum fluid flow	2 gpm	7.57 lpm
Outlet port size		
Model 77X542, 132230	3/4 inch npt	
Vent port size		
Model 77X542, 132230	3/8 inch npt	
Inlet	ISO 7241-1, Series B standard hydraulic quick disconnect 1/4 inch coupling	
Wetted parts	zinc plated steel parts, seals: Buna-N	
Dimensions	See Dimensions and Mounting (below)	
Weight	5.06 lbs	2.3 kgs

Recommended hose to reduce pressure drop: 3/4 inch ID, 20 feet (6.1 m) length for all lines.

California Proposition 65

 **WARNING:** This product can expose you to chemicals known to the State of California to cause cancer and birth defects or other reproductive harm. For more information, go to www.P65warnings.ca.gov.

Dimensions and Mounting

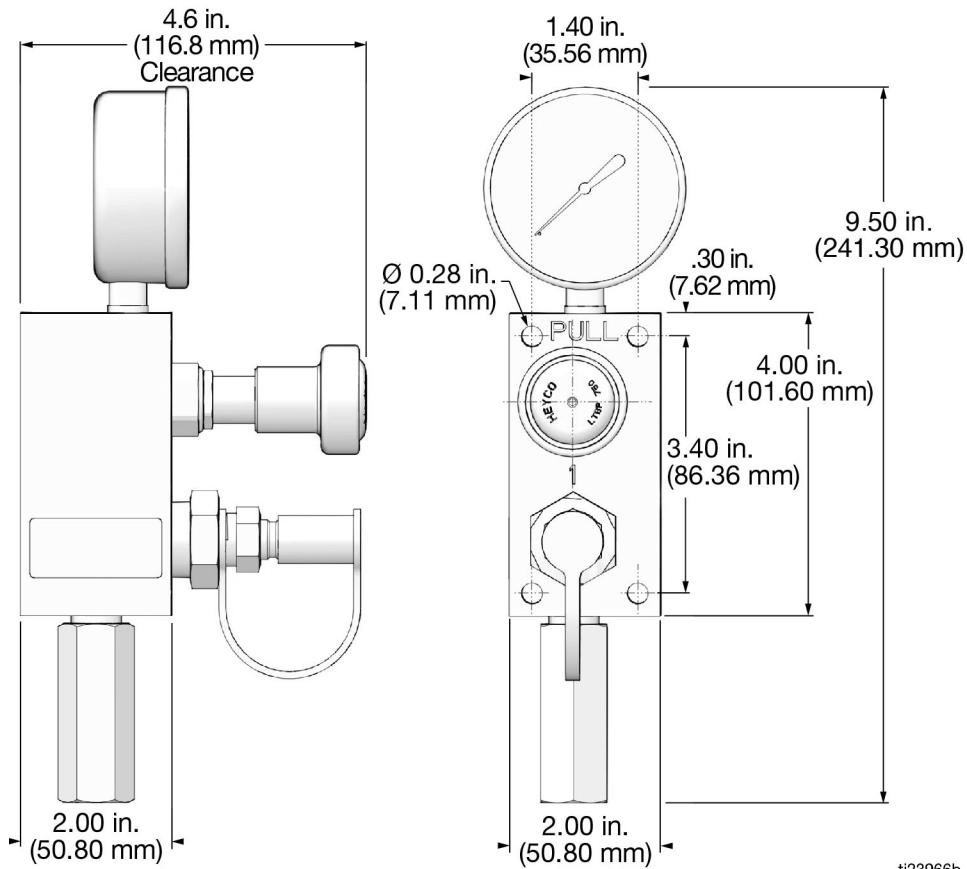

Graco Information

For the latest information about Graco products, visit www.graco.com.

For patent information, see www.graco.com/patents.

TO PLACE AN ORDER, contact your Graco distributor or call to identify the nearest distributor.

Phone: 612-623-6928 **or Toll Free:** 1-800-533-9655, **Fax:** 612-378-3590

All written and visual data contained in this document reflects the latest product information available at the time of publication. Graco reserves the right to make changes at any time without notice.

Original instructions. This manual contains English. MM 333393

Graco Headquarters: Minneapolis

International Offices: Belgium, China, Japan, Korea

GRACO INC. AND SUBSIDIARIES • P.O. BOX 1441 • MINNEAPOLIS MN 55440-1441 • USA

Copyright 2014, Graco Inc. All Graco manufacturing locations are registered to ISO 9001.

www.graco.com

Revision E, September 2022