

Air Controls

3A0293E

EN

Air controls for light and heavy duty Xtreme® Sprayer carts. For professional use only.

24E025, 24Y396

Air Controls for Light Duty Xtreme Package Carts

24W593

Air Controls for Xtreme XL Cart or Wall Mount Packages

24E013, 24Y101

Air Controls for Heavy Duty Xtreme Package Carts

244841

Accessory lubricator kit for Xtreme or Xtreme XL Packages

125 psi (0.86 MPa, 8.6 bar) Maximum Air Working Pressure depending on relief valve selected.



Important Safety Instructions

Read all warnings and instructions in this manual and the Xtreme Packages manual. Save these instructions.

24Y101

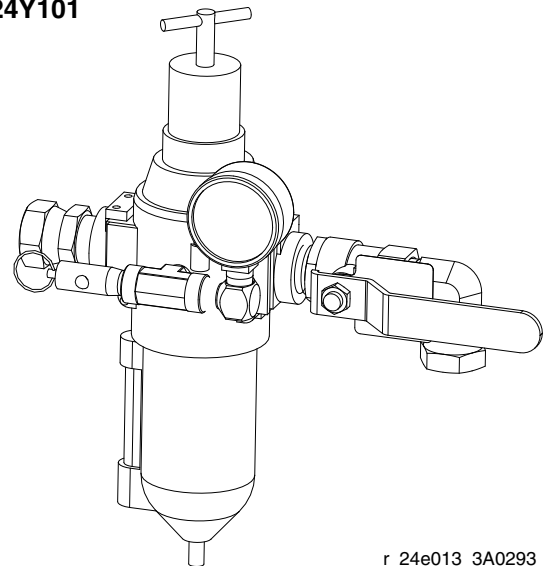

r_24e013_3A0293_1a

Installation



Prepare the Site

NOTE: Always use Genuine Graco Parts and Accessories, available from your Graco distributor. If you supply your own accessories, be sure they are adequately sized and pressure rated for your system.

Bring a compressed air supply line from the air compressor to the pump location. Be sure all air hoses are properly sized and pressure-rated for your system. Use only electrically conductive hoses. The air hose should have a 3/4 npsm(m) thread. Before installing any air line components, blow out the air lines to remove scale and other debris. Use pipe compound or tape sparingly and only on male threads.

Install a bleed-type shutoff valve in the air line upstream from all other air line components, to isolate them for servicing.

Kit Components (page 7)

						
<p>Use the bleed-type master air valve (3) to relieve air trapped between it and the pump when the valve is closed. This helps reduce the risk of serious injury, including fluid injection and splashing of fluid in the eyes or on the skin, and injury from moving parts if you are adjusting or repairing the pump.</p>						

Bleed-Type Master Air Valve (3)

Relieve air trapped between it and the air motor when the valve is closed. Be sure the bleed valve is easily accessible from the pump, and is located downstream from the air filter/regulator (1). FIG. 2

Air Filter/Regulator (1)

Controls pump speed and outlet pressure by adjusting the air pressure to the pump. It also removes harmful dirt and moisture from the compressed air supply. Locate the regulator as close as possible to the equipment it serves, but **upstream** from the bleed-type master air valve (3). Install the regulator in the air line so the air flow is in the direction of the arrow stamped on the body. FIG. 2.

Using the Pipe Port Inserts

To open the pipe port insert (A), remove the insert pin (S) and pull insert up in direction away from pin hole. Install new insert and reinsert pin.

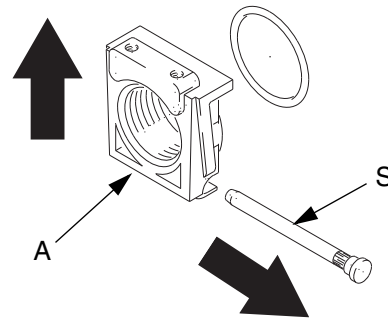

ti1249a

FIG. 1

Adding a Lubricator (Accessory)



To add an accessory air line lubricator to the kit, you must order Part No. 244841 Lubricator Accessory Kit.

1. Remove filter/regulator from mount bracket.
2. Remove the pin (B) from the outlet of the filter/regulator. FIG. 2.
3. Remove regulator cover.
4. Slide the threaded end insert off (13) with outlet fittings still attached.
5. Install the modular connector (2a) (with o-rings and grease provided) between the filter/regulator and the lubricator (L).
6. Install the threaded end insert (13) onto the outlet of the lubricator (L) with o-ring and grease.
7. Install the three retaining pins (B).

NOTE: On some configurations install the 3/4" npt fxf elbow with the 3/4" npt fxm elbow supplied with kit 244841, refer to instructions (form 406512) included with kit.

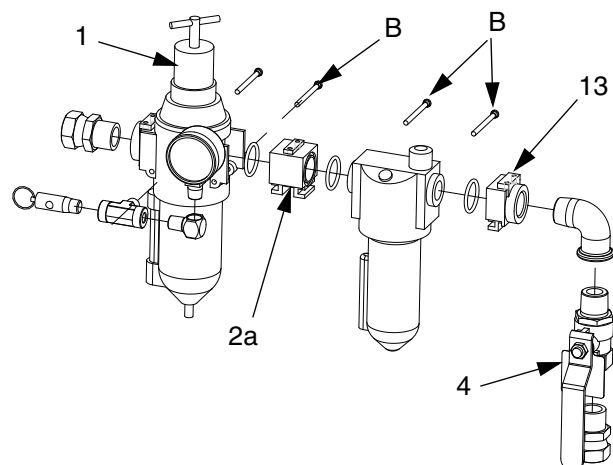

r_24e025_3A0293_4a

FIG. 2

The lubricator meters oil into the moving air stream to automatically lubricate air-operated motors. A manual adjustment in the housing (F), Fig. 2, sets the oil drip rate into the air stream, which can be monitored through a sight glass. One to two drops of oil per minute is common. Use an oil rated at 50 to 200 SUS (ISO grade 7 to 46) at 100°F (38°C), such as Graco motor oil, Part No. 202659.

Refill Lubricator

1. Unscrew the fill plug (L, FIG. 2) and pour in the oil. The lubricator's capacity is 7 oz. (0.2 liter).
2. Check the oil level with the side sight glass. The lubricator can be refilled with the system pressurized. However, always **relieve the system pressure** before removing the bowl for any reason.

Operation

Pressure Relief Procedure



1. Lock the gun trigger safety.
2. Close all bleed-type master air valves, including the bleed-type master air valve (3), supplied in your system. FIG. 2.
3. Turn the regulator T-handle all the way counterclockwise if you are removing the air filter/regulator (1) bowl, or servicing the air filter/regulator.
4. Open any fluid shutoff valves.
5. Unlock the gun trigger safety.
6. Hold a metal part of the gun firmly to the side of a grounded metal pail, and trigger the gun to relieve pressure.
7. Lock the gun trigger safety.
8. Open any fluid drain valves (required in your system), having a container ready to catch the drainage.
9. Leave the drain valve(s) open until you are ready to spray again.

*If you suspect that the spray tip or hose is completely clogged, or that pressure has not been fully relieved after following the steps above, **very slowly** loosen the tip guard retaining nut or hose end coupling and relieve pressure gradually, then loosen completely. Now clear the tip or hose.*

Adjusting the Air Regulator



Use the bleed-type master air valve (3) to relieve air trapped between it and the pump when the valve is closed. This helps reduce the risk of serious injury, including fluid injection and splashing of fluid in the eyes or on the skin, and injury from moving parts if you are adjusting or repairing the pump.

1. **To increase** the regulated air pressure, turn the T-handle **clockwise**.
2. **To decrease** the regulated air pressure, turn the T-handle **counterclockwise**.
3. To lock the regulator setting, tighten the jam nut.
4. Slowly open the air filter/regulator (1), FIG. 2. Use the filter/regulator to control pump speed and fluid pressure. Always use the lowest air pressure necessary to get the desired results. Higher pressures cause premature tip and pump wear.

Repair

Air Regulator

Repair Kits are available. Refer to page 6.

Every day, drain contaminants from the bowl before reaching the baffle level by opening the drain (D) at the bottom of the bowl (B). See FIG. 3.

Clean the air filter regularly to maximize filtering efficiency and to avoid excessive pressure drop. Fully **relieve pressure** to remove the bowl (B).

Clean the filter element and bowl using detergent and water or denatured alcohol. Use compressed air to blow out the filter body. Blow the filter element out from the inside.

Service the regulator, if the regulator fails to operate, operates roughly, or vibrates. Inspect all parts for wear or damage. Replace damaged parts. Refer to page 7.

Lubricate the bearing area, all o-rings, adjusting screw threads, and spring ends with no. 2 lithium-base grease. See. FIG. 3. Reassemble the regulator.

Lubricator Service (Accessory)

An accessory Lubricator Kit is available. Order Part No. 244841. Repair Kits are available (refer to page 7) for an accessory lubricator.

Clean the lubricator regularly to maximize efficiency. Fully **relieve pressure** and remove the lubricator from the air line.

Disassemble the lubricator.

Clean the parts with detergent and water or denatured alcohol. Wipe dry with a clean, soft cloth.

Use compressed air to blow dirt and contaminants out of the lubricator body. Inspect all parts for wear or damage. Replace damaged parts.

Clean the sight glass (S) thoroughly. See Fig. 4. Do not leave solvent residue in the sight glass as it may attack or weaken the glass. If the sight glass appears damaged, replace it immediately.

Reassemble the lubricator.

Repair Kits

116521, 17C498 Air Filter/Regulator

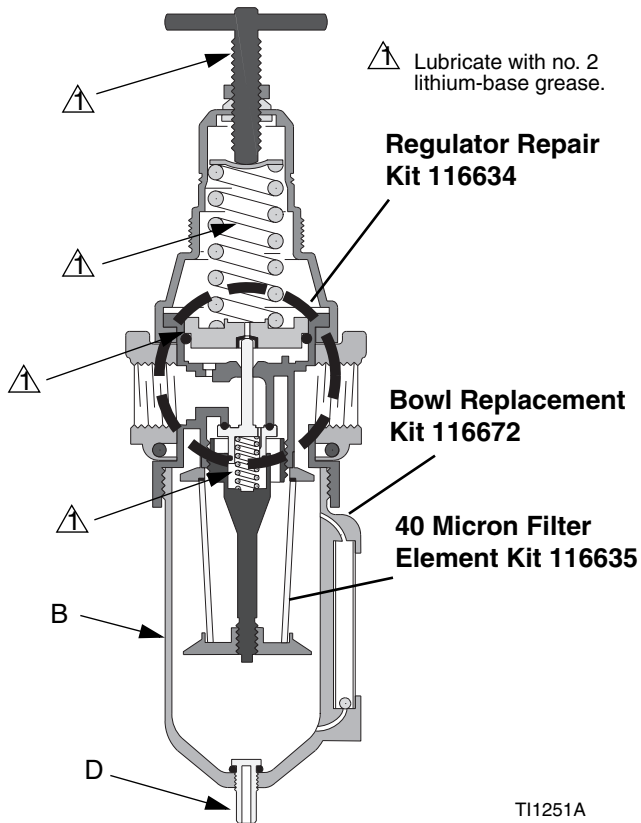

FIG. 3: 116521, 17C498 Repair Kits

C11034 Lubricator

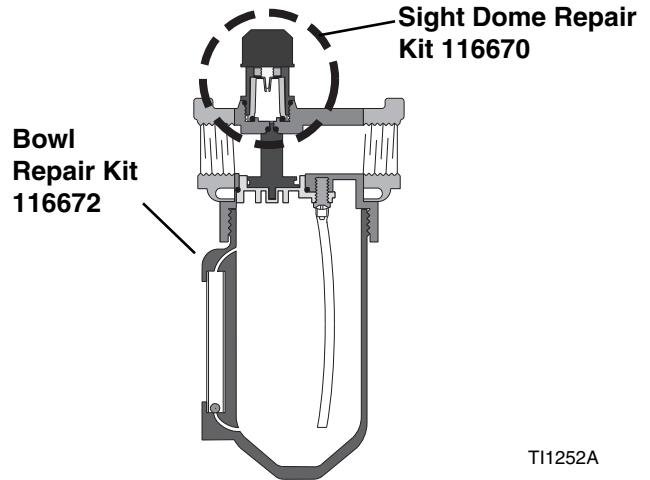
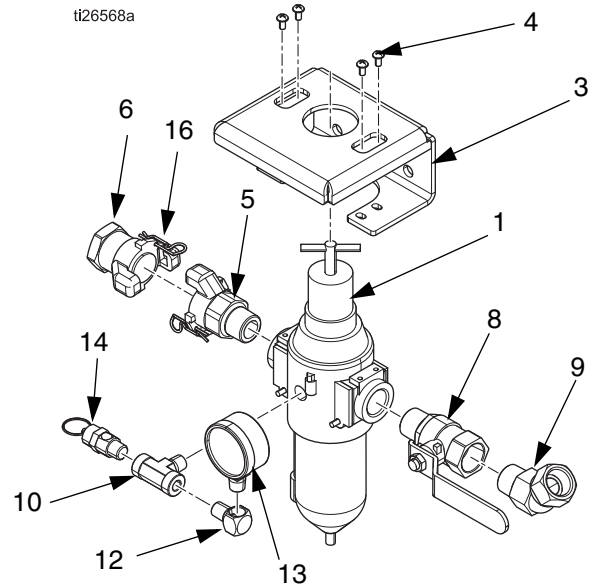

FIG. 4: C11034 Repair Kits

Parts

24Y101 Xtreme Heavy Duty Cart Air Controls, Series C

Ref. No.	Part No.	Description	Qty.
1	116521	REGULATOR, filter, air	1
3	17B747	BRACKET	1
4	106084	SCREW, mach, pan hd	4
5	113429	COUPLING	1
6	113430	COUPLING	1
8	113218	VALVE, ball, vented, 3/4	1
9	105281	FITTING, union, swivel, 45	1
10	108638	FITTING, pipe, tee	1
12	100840	FITTING, elbow, street	1
13	100960	GAUGE, press air	1
14*		VALVE, safety	1
16	16W586	CABLE, lanyard, whipcheck	1



24E013 Xtreme Heavy Duty Cart Air Controls, Series A and B

Ref. No.	Part No.	Description	Qty.
1	116521	REGULATOR, filter, air	1
3	113218	VALVE, ball, vented, 3/4	1
5	157785	FITTING, swivel	1
6	108638	FITTING, pipe, tee	1
7	100840	FITTING, elbow, street	1
8	100960	GAUGE, press air	1
9*		VALVE, safety	1
10	194545	CONNECTOR, bulkhead	1
11	160327	FITTING, union adapter, 90°	1

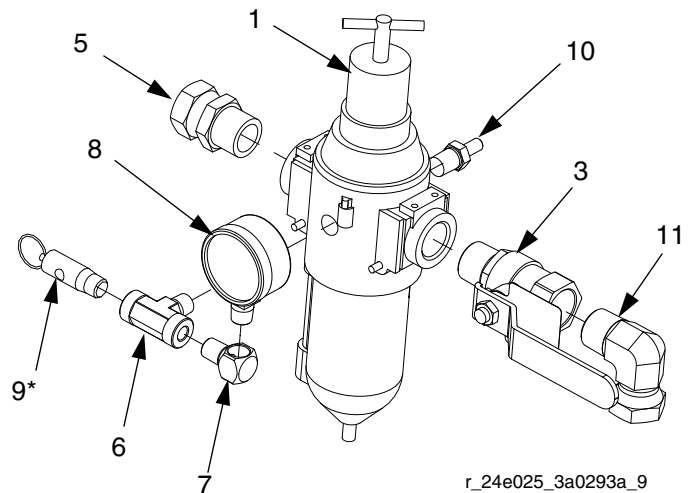

* Not included with air controls. Replace with appropriate part number from table below according to pump ratio.

Pump Ratio	Part No.	Pressure Relief
X25-X70, XL70	113498	110 psi (0.7 MPa, 7.6 bars)
XL45	114055	105 psi (0.7 MPa, 7.2 bars)
X80	103347	100 psi (0.7 MPa, 6.8 bars)
XL80	16M190	95 psi (0.6 MPa, 6.5 bars)
X90	116643	90 psi (0.6 MPa, 6.2 bars)
XL95	120306	85 psi (0.6 MPa, 5.9 bars)

24E025 Xtreme Lightweight Cart Air Controls, Series A and B

Ref. No.	Part No.	Description	Qty.
1	116521	REGULATOR, filter, air	1
2	160032	FITTING, nipple	1
3	113218	VALVE, ball, vented, 3/4	1
4	122327	ELBOW, street, pipe, 90°	1
5	157785	FITTING, swivel	2
6	108638	FITTING, pipe, tee	1
7	100840	FITTING, elbow, street	1
8	100960	GAUGE, press air	1
9*		VALVE, safety	1

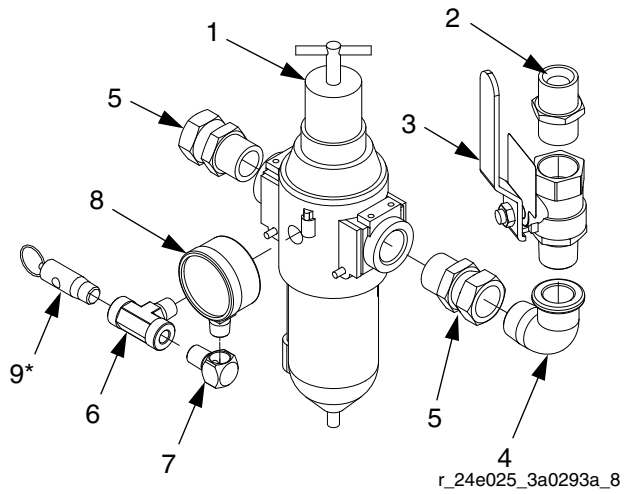

24Y396 Xtreme Lightweight Cart Air Controls, Series C

Ref. No.	Part No.	Description	Qty.
1	116521	REGULATOR, filter, air	1
3	17G536	BRACKET	1
4	106084	SCREW, mach, pan hd	4
5	113429	COUPLING	1
6	113430	COUPLING	1
8	113218	VALVE, ball, vented, 3/4	1
9	105281	FITTING, union, swivel, 45	1
10	108638	FITTING, pipe, tee	1
12	100840	FITTING, elbow, street	1
13	100960	GAUGE, press air	1
14*		VALVE, safety	1
16	16W586	CABLE, lanyard, whipcheck	1

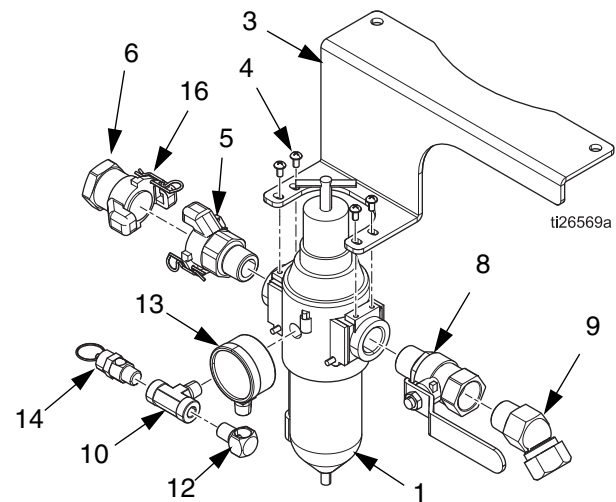

* Not included with air controls. Replace with appropriate part number from table below according to pump ratio.

Pump Ratio	Part No.	Pressure Relief
X25-X70, XL70	113498	110 psi (0.7 MPa, 7.6 bars)
XL45	114055	105 psi (0.7 MPa, 7.2 bars)
X80	103347	100 psi (0.7 MPa, 6.8 bars)
XL80	16M190	95 psi (0.6 MPa, 6.5 bars)
X90	116643	90 psi (0.6 MPa, 6.2 bars)
XL95	120306	85 psi (0.6 MPa, 5.9 bars)

24W593, For Xtreme XL Heavy Duty Cart or Wall Mount Packages

Ref. No.	Part No.	Description	Qty.
1	17C498	REGULATOR, filter, air, 1 in. npt	1
2	100467	ELBOW, street, pipe; wall mount only	1
3	17B747	BRACKET	1
4	106084	SCREW, mach, pan hd	4
5	127784	COUPLING, universal, 1 in. npt(m)	1
6	127785	COUPLING, universal, 1 in. npt(f)	1
7	158585	NIPPLE	1
8	113163	VALVE, ball, vented	1
9	127945	FITTING, swivel, 45°, 1 npt x 1 npsm	1
10	108638	FITTING, pipe, tee	1
12	100840	FITTING, elbow, street	1
13	100960	GAUGE, pressure, air	1
14*		VALVE, safety	1
16	16W586	CABLE, lanyard, whipcheck	1

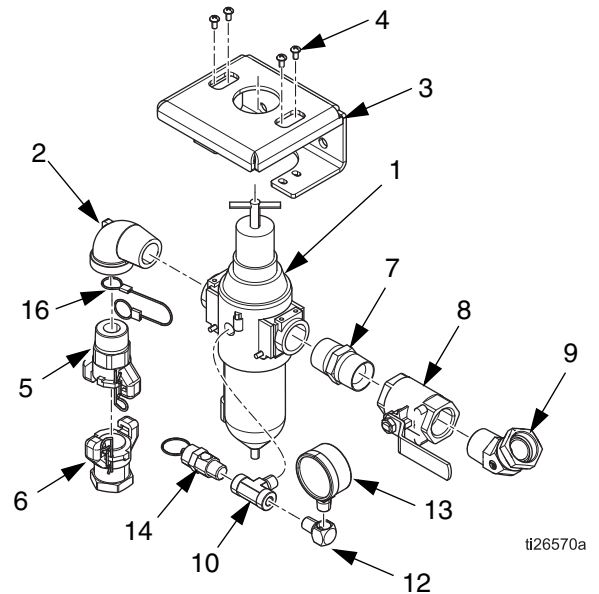

* Not included with air controls. Replace with appropriate part number from table below according to pump ratio.

Pump Ratio	Part No.	Pressure Relief
X25-S70, XL70	113498	110 psi (0.7 MPa, 7.6 bars)
XL45	114055	105 psi (0.7 MPa, 7.2 bars)
X80	103347	100 psi (0.7 MPa, 6.8 bars)
XL80	16M190	95 psi (0.6 MPa, 6.5 bars)
X90	116643	90 psi (0.6 MPa, 6.2 bars)
XL95	120306	85 psi (0.6 MPa, 5.9 bars)

244841 Lubricator Conversion Kit

Ref. No.	Part No.	Description	Qty.
1	C11034	LUBRICATOR, air	1
2	116522	AIR CONTROL, conversion kit (includes 2a-2c)	1
2a		ADAPTER	1
2b		PINS, retaining	2
2c		O-RING	2
4*	100549	ELBOW, street, 90°, 3/4 npt (m x f)	1

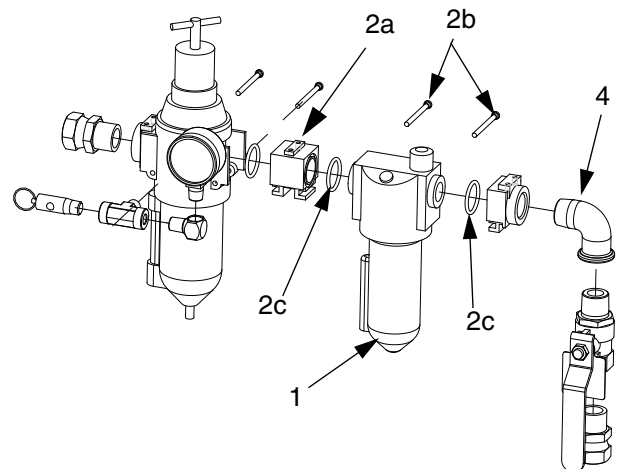

* Elbow not used in all configurations.

Technical Data

Air Controls		
	US	Metric
Maximum air input pressure	250 psi	1.7 MPa, 17.2 bar
Gauge Port Size (Air Regulator)	1/4 npt(f)	
Air Filter Element	40 micron polypropylene screen	
Maximum operating temperature	122°F	50°C
Air Inlet Size		
Xtreme	3/4 npsm(f)	
Xtreme XL	1 in. npt(f)	
Air Outlet Size		
Xtreme	3/4 npt(f)	
Xtreme XL	1 in. npsm(f)	

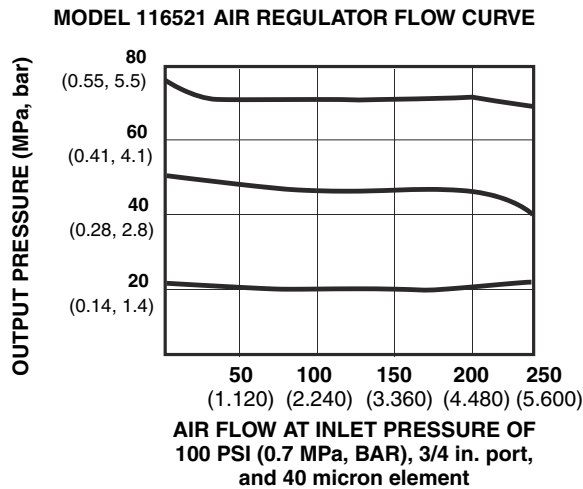

NOTE: 17C498 is the same regulator as 116521 except with 1 in. npt end fittings instead of 3/4 npt.

Graco Standard Warranty

Graco warrants all equipment referenced in this document which is manufactured by Graco and bearing its name to be free from defects in material and workmanship on the date of sale to the original purchaser for use. With the exception of any special, extended, or limited warranty published by Graco, Graco will, for a period of twelve months from the date of sale, repair or replace any part of the equipment determined by Graco to be defective. This warranty applies only when the equipment is installed, operated and maintained in accordance with Graco's written recommendations.

This warranty does not cover, and Graco shall not be liable for general wear and tear, or any malfunction, damage or wear caused by faulty installation, misapplication, abrasion, corrosion, inadequate or improper maintenance, negligence, accident, tampering, or substitution of non-Graco component parts. Nor shall Graco be liable for malfunction, damage or wear caused by the incompatibility of Graco equipment with structures, accessories, equipment or materials not supplied by Graco, or the improper design, manufacture, installation, operation or maintenance of structures, accessories, equipment or materials not supplied by Graco.

This warranty is conditioned upon the prepaid return of the equipment claimed to be defective to an authorized Graco distributor for verification of the claimed defect. If the claimed defect is verified, Graco will repair or replace free of charge any defective parts. The equipment will be returned to the original purchaser transportation prepaid. If inspection of the equipment does not disclose any defect in material or workmanship, repairs will be made at a reasonable charge, which charges may include the costs of parts, labor, and transportation.

THIS WARRANTY IS EXCLUSIVE, AND IS IN LIEU OF ANY OTHER WARRANTIES, EXPRESS OR IMPLIED, INCLUDING BUT NOT LIMITED TO WARRANTY OF MERCHANTABILITY OR WARRANTY OF FITNESS FOR A PARTICULAR PURPOSE.

Graco's sole obligation and buyer's sole remedy for any breach of warranty shall be as set forth above. The buyer agrees that no other remedy (including, but not limited to, incidental or consequential damages for lost profits, lost sales, injury to person or property, or any other incidental or consequential loss) shall be available. Any action for breach of warranty must be brought within two (2) years of the date of sale.

GRACO MAKES NO WARRANTY, AND DISCLAIMS ALL IMPLIED WARRANTIES OF MERCHANTABILITY AND FITNESS FOR A PARTICULAR PURPOSE, IN CONNECTION WITH ACCESSORIES, EQUIPMENT, MATERIALS OR COMPONENTS SOLD BUT NOT MANUFACTURED BY GRACO. These items sold, but not manufactured by Graco (such as electric motors, switches, hose, etc.), are subject to the warranty, if any, of their manufacturer. Graco will provide purchaser with reasonable assistance in making any claim for breach of these warranties.

In no event will Graco be liable for indirect, incidental, special or consequential damages resulting from Graco supplying equipment hereunder, or the furnishing, performance, or use of any products or other goods sold hereto, whether due to a breach of contract, breach of warranty, the negligence of Graco, or otherwise.

FOR GRACO CANADA CUSTOMERS

The Parties acknowledge that they have required that the present document, as well as all documents, notices and legal proceedings entered into, given or instituted pursuant hereto or relating directly or indirectly hereto, be drawn up in English. Les parties reconnaissent avoir convenu que la rédaction du présente document sera en Anglais, ainsi que tous documents, avis et procédures judiciaires exécutés, donnés ou intentés, à la suite de ou en rapport, directement ou indirectement, avec les procédures concernées.

Graco Information

For the latest information about Graco products, visit www.graco.com.

For patent information, see www.graco.com/patents.

TO PLACE AN ORDER, contact your Graco distributor or call to identify the nearest distributor.

Phone: 612-623-6921 **or Toll Free:** 1-800-328-0211 **Fax:** 612-378-3505

All written and visual data contained in this document reflects the latest product information available at the time of publication. Graco reserves the right to make changes at any time without notice.

For patent information, see www.graco.com/patents.

Original instructions. This manual contains English. MM 3A0293

Graco Headquarters: Minneapolis
International Offices: Belgium, China, Japan, Korea

GRACO INC. AND SUBSIDIARIES • P.O. BOX 1441 • MINNEAPOLIS MN 55440-1441 • USA
Copyright 2010, Graco Inc. All Graco manufacturing locations are registered to ISO 9001.

www.graco.com
Revision E, July 2015