

## Winch Kit for RoadLazer™ RoadPak™ Line Striping System

3A1307B

EN

### Model 24G773



#### Important Safety Instructions

For complete warnings and safety instructions see RoadLazer™ RoadPak™ Line Striper System manual. Save these instructions.



The RoadPak Winch Kit is to be used as a safety device for the operator to lift the gun arm off the ground and slowly and safely drive out of the way of traffic to a safe place where the gun arm can properly be stowed for transporting. When the operator is not spraying, the vehicle should not be operated unless the gun arm is stowed in the proper position. See RoadLazer™ RoadPak™ Line Striper System manual.

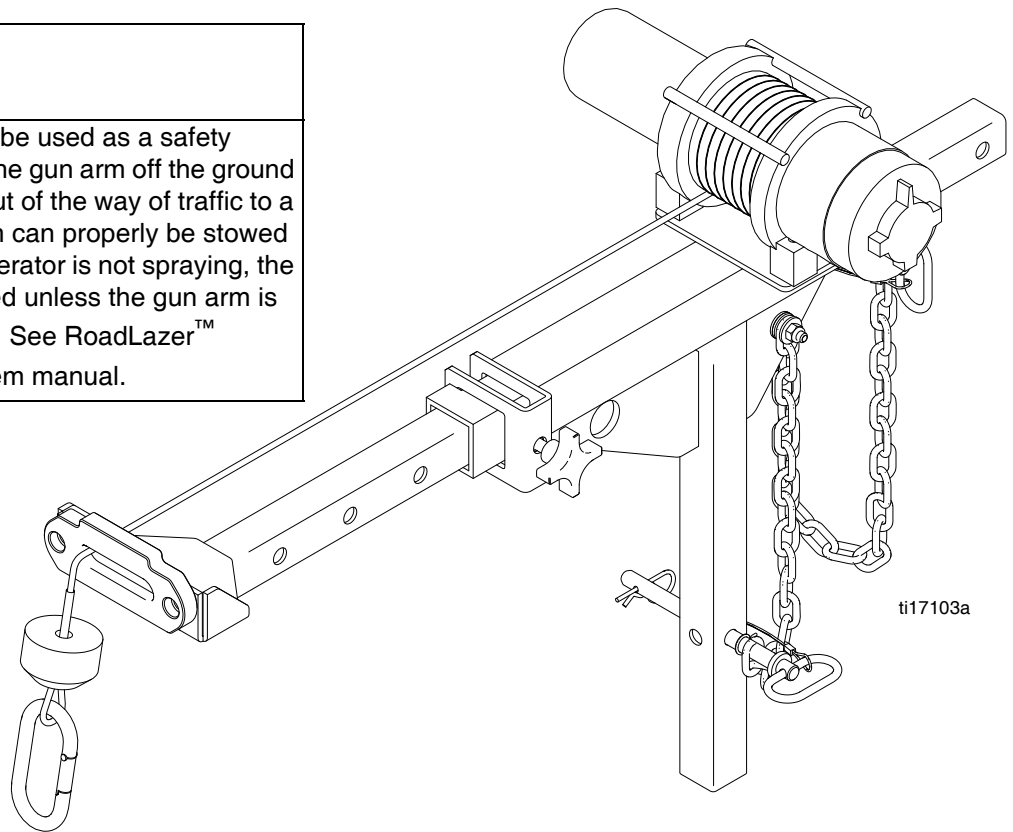

ti17103a

# Winch Kit Installation

1. Assemble adaptor bracket (1) to height adjustment bracket on both sides. Fasten with bolts (6), washers (7), and nuts (8). Torque to 28 ft-lb.

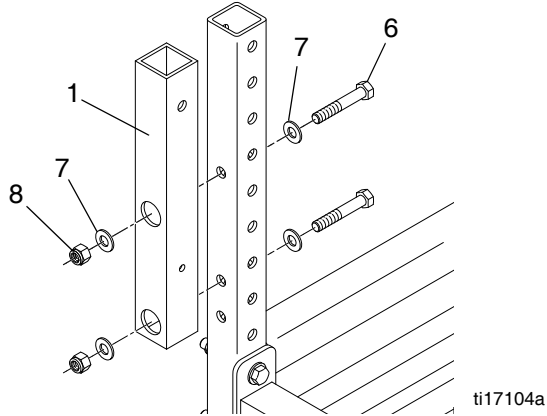

2. Use four bolts and lock washers (supplied) to assemble winch (5) onto winch arm (2).

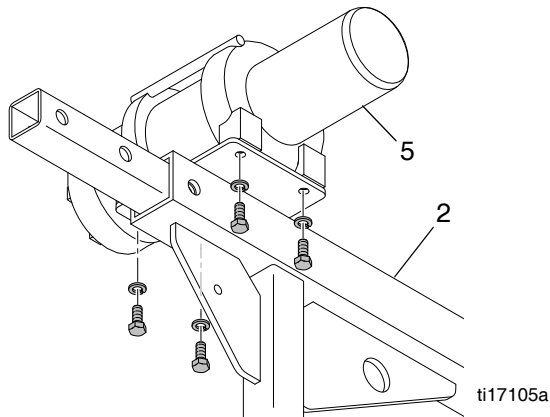

3. Use bolts, washers, and nuts (supplied) to assemble cable guide onto winch arm bracket (3).

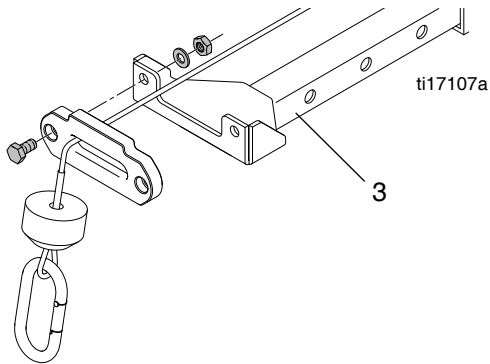

4. Slide winch arm bracket (3) into winch arm (2) and secure into place by tightening extension clamp (15) and inserting the safety pin.

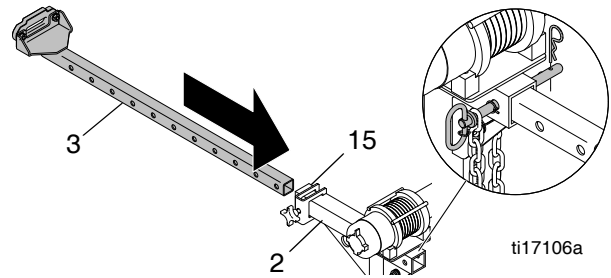

5. Insert winch assembly into one of the adapter brackets (1) and secure with pin (9).

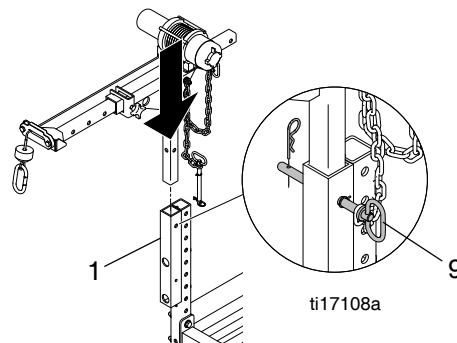

6. Install winch switch (20) and connector bracket (17) next to the battery on the RoadPak frame. Fasten with screws (16).

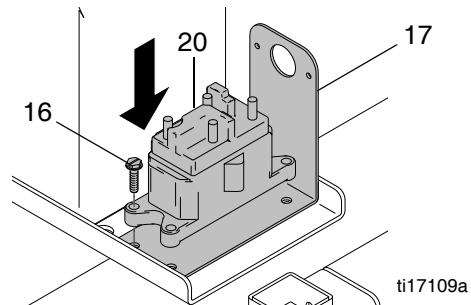

7. Pull the wires of the winch control connector (19) through the hole of the connector bracket and fasten the connector to the bracket with screws (18).

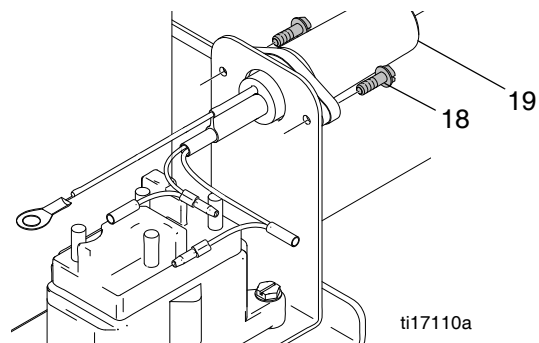

8. Connect blue and yellow cables (21) from the winch terminals to blue and yellow color-coded terminals on winch switch terminal.

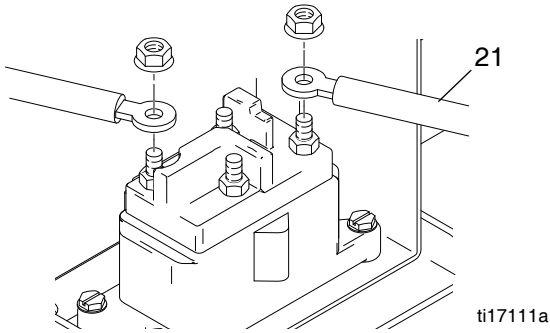

9. Disconnect ground terminal on battery. Connect red and black cables (21) to red and black color-coded winch switch terminals. Attach the red cable from the winch control connector and power cable from the winch switch to the positive terminal on the battery. Then connect the black cable to the ground terminal on the battery. See **Wiring Diagram**, page 4.

10. Connect the green plugs from the winch control connector and the winch switch as shown in **Wiring Diagram**, page 4.

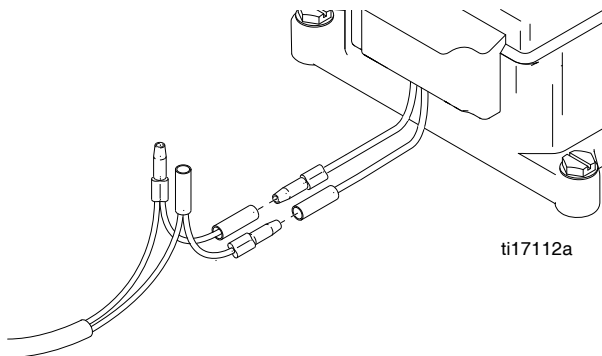

11. Plug in winch controller (19) to the connector and route to the cab of the vehicle. Properly protect and secure all wires to keep from damaging them during every day use.

12. Adjust the winch arm (3) so it is in line with the lifting point on the gun arm. Ensure the winch arm is secured by pinning it and tightening the extension clamp (15).

13. Use the buttons on the controller to lower the winch. Connect the winch hook (22) to the lifting point on the gun arm.

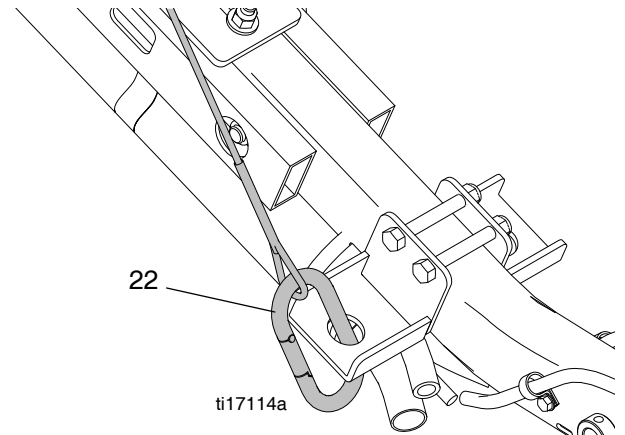

14. When transporting the RoadPak system, the gun arm must be properly stowed (see manual 3A1214) and the winch arm must be adjusted to fit within the width of the vehicle.

# Wiring Diagram

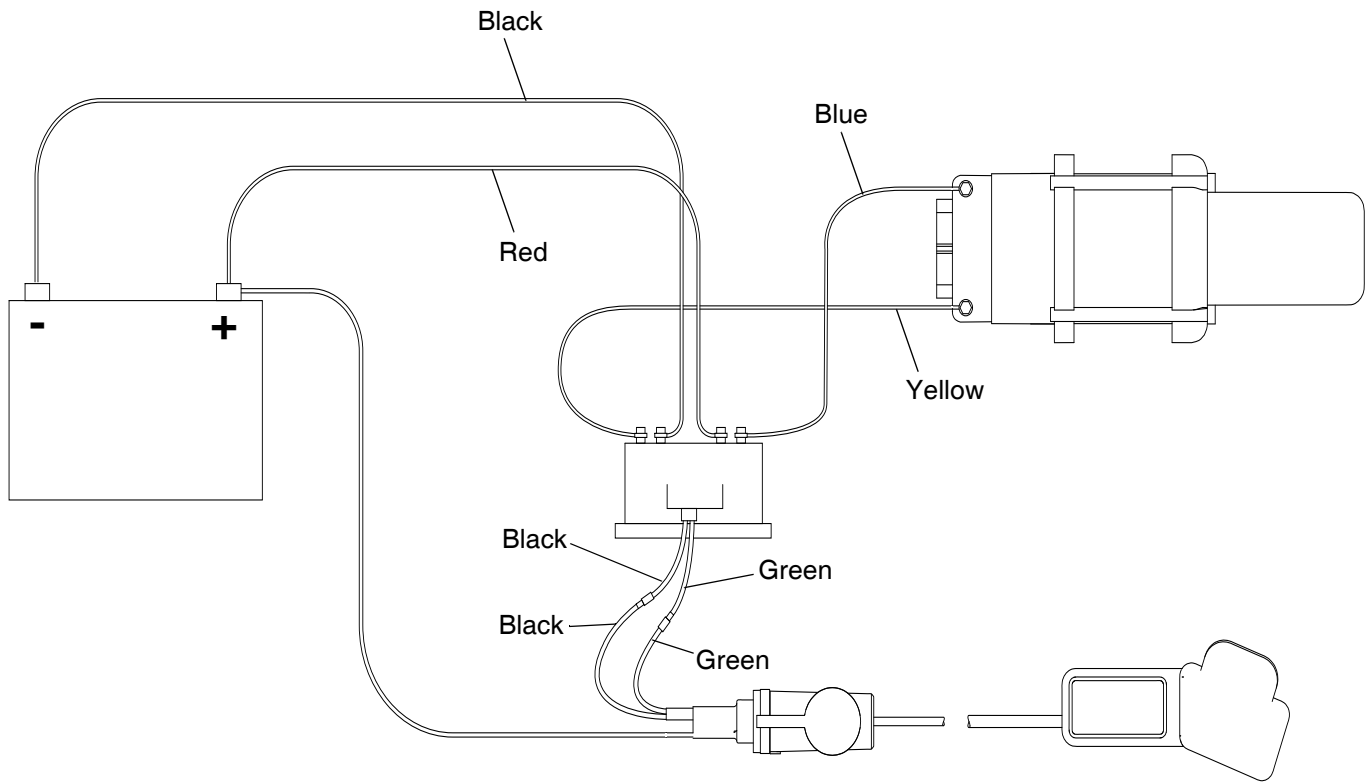

ti17113a

# Parts List

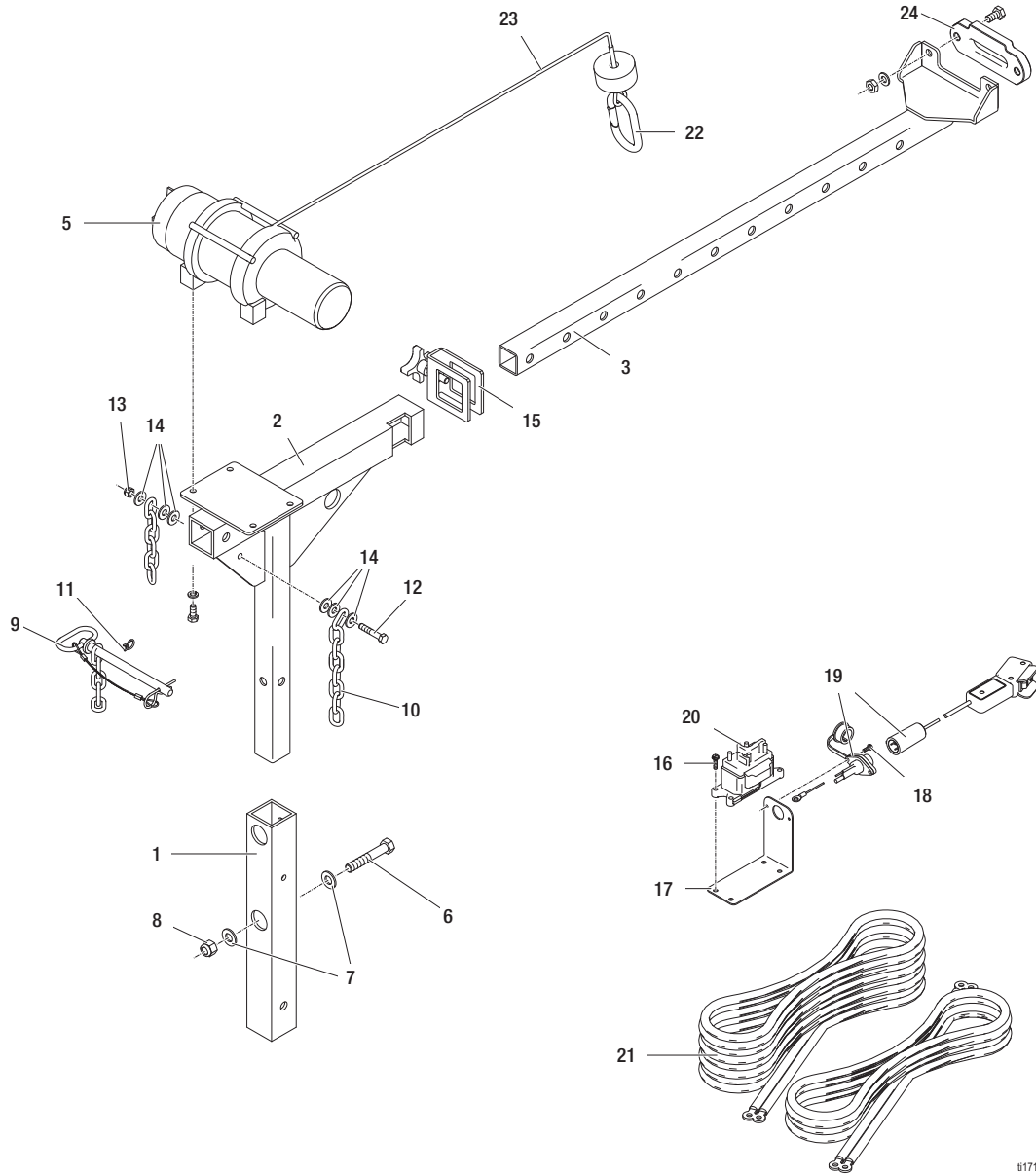

t17115b

Ref.	Part	Description	Qty.	Ref.	Part	Description	Qty.
1	16G688	BRACKET, adapter, winch, painted	2	15	238813	CLAMP, extension	1
2	24G839	ARM, winch, painted	1	16	107439	SCREW, mach, hex HD	4
3	24G841	BRACKET, arm, winch, painted	1	17	16H234	BRACKET, mtg., connector, winch ctrl	1
5	16G458	WINCH, RoadLazer	1	18	117501	SCREW, mach, slot hex wash HD	2
6	101147	SCREW, cap, hex HD	4	19	16H069	SWITCH, corded remote/plug in	1
7	109570	WASHER, plain	8	20	16F346	SWITCH, winch, contactor	1
8	801020	NUT, lock, hex	4	21	16H070	WIRE, assemblies, battery/winch	1
9	115473	PIN, hitch	2	22	16H068	CONNECTOR, 1-3/8 in. eye dia., carbiner	1
10	186812	CHAIN, ground 3.5 HP	2	23	16H067	CABLE, 3/16 in. dia., blue	1
11	M71635	CLAMP, hose	2	24	25R141	BRACKET, end, winch (includes mounting hardware)	1
12	100678	SCREW, cap hex HD	1				
13	111040	NUT, lock, insert, nylock, 5/16	1				
14	100023	WASHER, flat	6				

*All written and visual data contained in this document reflects the latest product information available at the time of publication.  
Graco reserves the right to make changes at any time without notice.*

Original instructions. This manual contains English. MM 3A1307

**Graco Headquarters:** Minneapolis

**International Offices:** Belgium, China, Japan, Korea

**GRACO INC. AND SUBSIDIARIES • P.O. BOX 1441 • MINNEAPOLIS MN 55440-1441 • USA**  
**Copyright 2010, Graco Inc. All Graco manufacturing locations are registered to ISO 9001.**

[www.graco.com](http://www.graco.com)

Revision B, March 2021