

# CleanShot Replacement Kit for Fine Finish Hand-Held Sprayers

3A1701B  
ENG



## IMPORTANT SAFETY INSTRUCTIONS

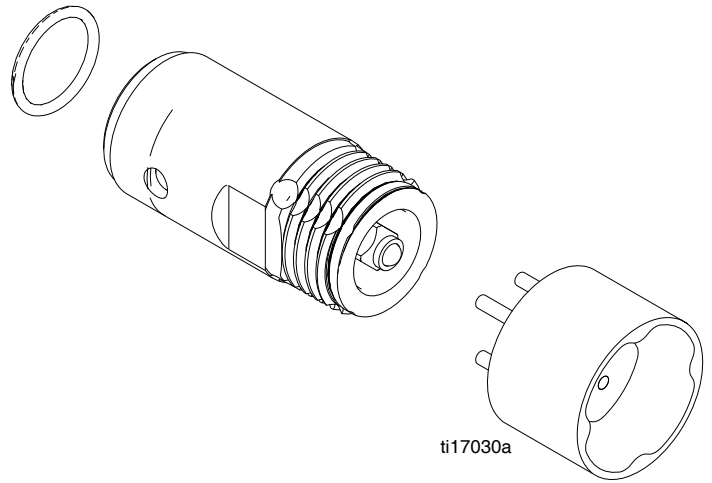

For complete warnings and safety instructions, see sprayer manual.

## CleanShot Replacement Kit 24J433



ti17030a

## Pressure Relief Procedure

			
<p>Do not operate or spray near children. Do not aim the sprayer at, or spray any person or animal. Keep hands and other body parts away from the front of the sprayer. For example, do not try to stop the paint flow with any part of the body.</p> <p>This sprayer builds up an internal pressure of 1700 psi during use. Follow this <b>Pressure Relief Procedure</b> whenever you stop spraying and before cleaning, checking, servicing, or transporting equipment to prevent serious injury.</p>			

1. Engage trigger lock.

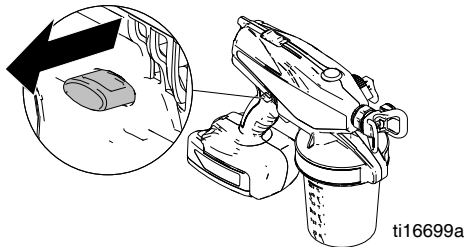

ti16699a

2. Put prime/relief valve UP to release pressure.

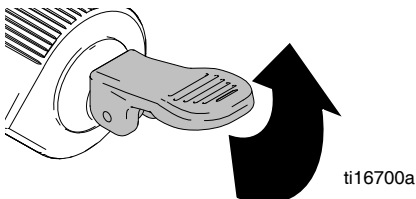

ti16700a

# Replacement Instructions



1. Perform **Pressure Relief Procedure**, page 1.
2. Remove Tip/Guard Assembly.

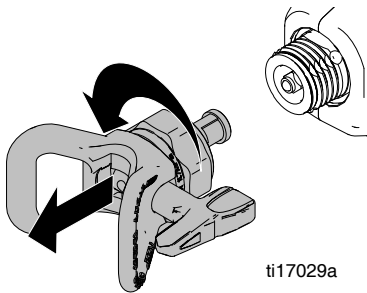

3. Place CleanShot tool onto socket wrench with 1/4 in. extension.

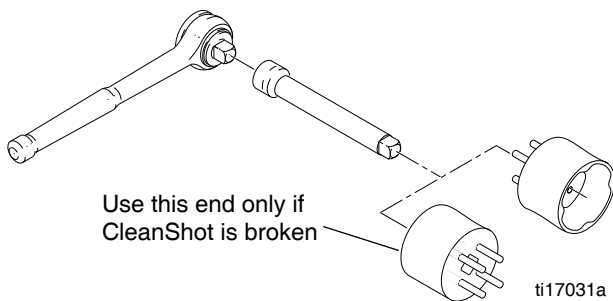

4. Use four-flute end of supplied tool to remove old CleanShot valve.

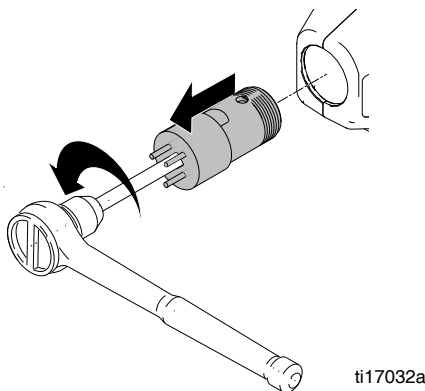

**NOTE:** If CleanShot valve has been broken, use four-pin end of supplied tool to remove old CleanShot.

**NOTICE**

**IT IS CRITICAL** that the four-pins of the socket be **FULLY** inserted into the four holes of the broken valve, and the ratchet be pushed into the valve as it is being removed. If the socket is not fully inserted, the pins may break and the tool will be destroyed.

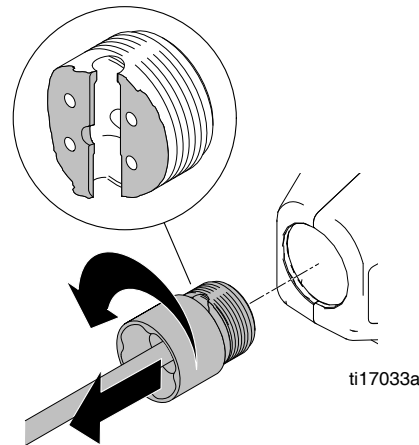

5. Install new CleanShot valve, make sure o-ring between pump and valve is installed. Torque valve to 150 in-lb.

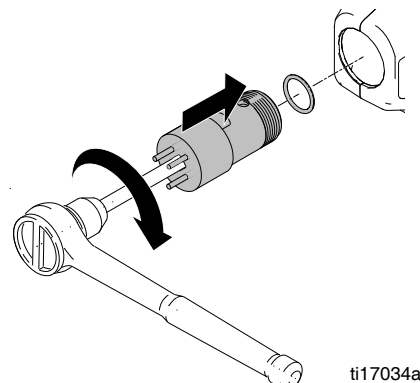

*All written and visual data contained in this document reflects the latest product information available at the time of publication. Graco reserves the right to make changes at any time without notice.*

Original instructions. **This manual contains English. MM 3A1701**  
**Graco Headquarters:** Minneapolis

**International Offices:** Belgium, China, Japan, Korea

**GRACO INC. P.O. BOX 1441 MINNEAPOLIS, MN 55440-1441**

**Copyright 2011, Graco Inc. is registered to ISO 9001**

www.graco.com

Revision B, May 2019