

24N319 Round Spray Kit

3A2499D
EN

To convert a Pro Xp™
Electrostatic Air-Assisted Spray Gun to a round spray pattern. For professional use only.



Important Safety Instructions

Read all warnings and instructions in this manual and in your Pro Xp Electrostatic Air-Assisted Spray Gun manual. Save these instructions.

*3000 psi (21 MPa, 210 bar) Maximum
Fluid Working Pressure
100 psi (0.7 MPa, 7.0 bar) Maximum Air
Working Pressure*

*See page 4 for part numbers. Gun is not
included.*

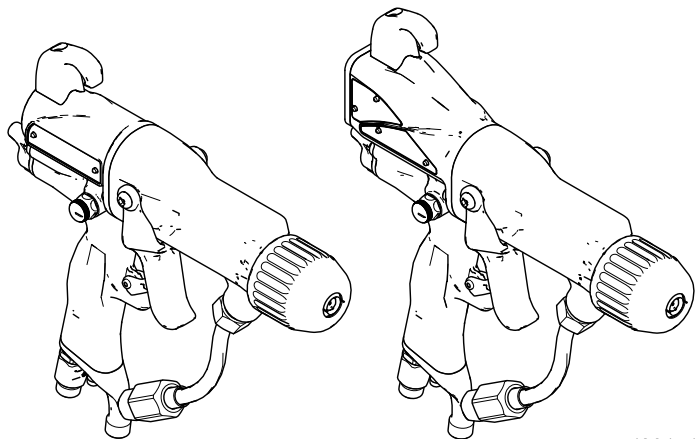

ti20151a

Installation

				
<p>To reduce the risk of injury, follow the Pressure Relief Procedure in your Pro Xp manual before installing this kit.</p>				

1. Relieve the pressure.
2. Remove the retaining ring, air cap/tip guard, and spray tip.

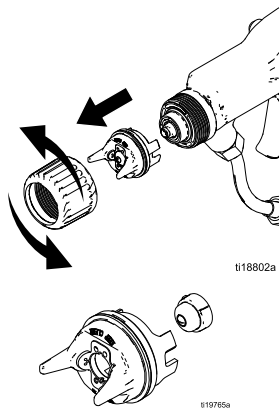

3. Flush the gun as instructed in your gun manual. Relieve the pressure.

NOTICE

Do not operate the gun with a damaged electrode (4a). Make sure the electrode is in place before installing the air cap/electrode assembly (4).

NOTE: The kit includes a large retainer (2) for a larger pattern, and a small retainer (3) for a smaller pattern.

4. Check that the electrode (4a) is in place in the air cap. The two ends of the electrode should be inserted in the two holes on the back of the air cap, and should protrude through the front of the air cap. Install the diffuser/seal assembly (1), air cap/electrode assembly (4), and desired retainer (2 or 3) onto the gun. Tighten the retainer firmly.

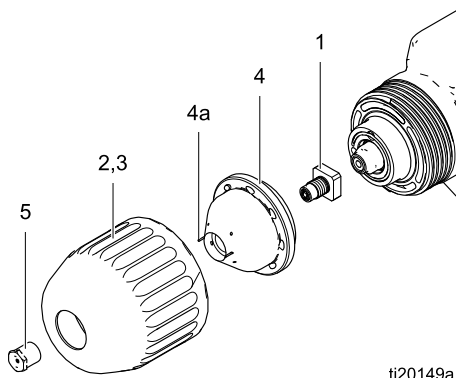

NOTICE

Overtightening the spray tip (5) can damage the tip and cause poor spray performance.

5. Install the spray tip (5) and tighten using the wrench (6). When tightening, only grip the end of the wrench with your fingers. Do not grip the wrench cross-arms (E).

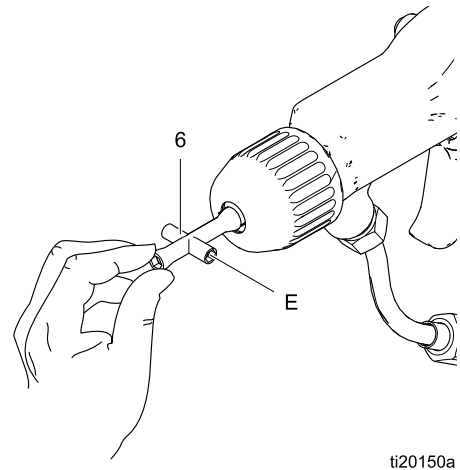

6. Adjust the spray pattern as explained in the Gun Setup Checklist of your Pro Xp gun manual.

NOTE: The recommended spraying distance from the front of the gun to the object being sprayed is 8–12 in. (203–305 mm). Round spray tips emit a soft pattern. If the gun is too far from the object, the floating charged particles may be attracted to the gun or operator instead of to the grounded object.

NOTE: See [Round Spray Tips, page 5](#), for fluid flow information. See [Spray Pattern Troubleshooting, page 4](#), to correct spray pattern problems.

NOTE: If the spray tip clogs, stop spraying immediately and relieve pressure. Clean the tip as explained in your Pro Xp gun manual. To help reduce spray tip clogging, clean or replace the fluid filter supplied with the gun.

Parts

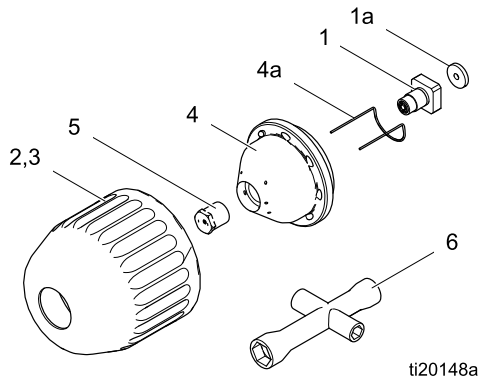

Ref. No.	Part No.	Description	Qty
1	236768	DIFFUSER/SEAL ASSEMBLY; includes item 1a	1
1a	183459	SEAL; UHMWPE	1
2	24R776	RETAINER, large (shown)	1
3	24R775	RETAINER, small (not shown)	1
4	245294	AIR CAP/ELECTRODE ASSEMBLY; includes item 4a	1
4a	198748	ELECTRODE	1
5	236xxx	TIP ASSEMBLY; customer's choice; see Round Spray Tips, page 5	1
6	189780	WRENCH	1

Spray Pattern Troubleshooting

NOTE: Some spray pattern problems are caused by the improper balance between air and fluid.

Problem	Cause	Solution
Spray is too forceful (high velocity).	Air flow too high.	Use gun atomizing air adjustment valve to reduce air flow.
	Spray tip worn.	Replace tip.
	Diffuser worn.	Replace diffuser.
	Fluid flow too high.	Use smaller tip or lower pressure
Spray gun spitting.	Air flow too low.	Use gun atomizing air adjustment valve to increase air flow.
	Tip size is too large.	Use smaller tip.
Tip clogging.	Paint not properly filtered.	Clean or replace the gun filter. Install inline filter or clean/replace inline filter.
	Tip size is too small.	Use larger tip.
Distorted spray pattern (heavy to one side).	Tip is clogged.	See "Tip clogging," above.
	Spray tip worn or damaged.	Replace tip.

Round Spray Tips

Part No.	Size No.	Approximate Flow Rates for Light to Medium Viscosity Coatings (20–40 centipoise)*		
		300 psi (2.1 MPa, 21 bar)	600 psi (4.2 MPa, 42 bar)	1200 psi (8.4 MPa, 84 bar)
236836	4A	2.5 oz/min (73 cc/min)	4.1 oz/min (120 cc/min)	5.7 oz/min (170 cc/min)
236837	6A	2.9 oz/min (86 cc/min)	5.1 oz/min (150 cc/min)	7.4 oz/min (220 cc/min)
236838	7A	3.2 oz/min (95 cc/min)	5.4 oz/min (160 cc/min)	7.8 oz/min (230 cc/min)
236839	5B	5.4 oz/min (160 cc/min)	7.8 oz/min (230 cc/min)	11.0 oz/min (330 cc/min)
236840	7B	7.1 oz/min (210 cc/min)	9.1 oz/min (270 cc/min)	14.2 oz/min (420 cc/min)
236841	9B	8.8 oz/min (260 cc/min)	11.8 oz/min (350 cc/min)	17.9 oz/min (530 cc/min)
236842	11B	11.8 oz/min (350 cc/min)	16.2 oz/min (480 cc/min)	23.7 oz/min (700 cc/min)

* Flows are based on white acrylic, enamel paint.

Recommended Filter Sizes for Round Spray Tips

Filter Size	Filter Part No.	Tip Part No.	Tip Size No.
200 mesh	25N893	236836	4A
		236837	6A
150 mesh	25N891	236837	6A
		236838	7A
100 mesh	238562	236839	5B
		236840	7B
		236841	9B
		236842	11B

Graco Standard Warranty

Graco warrants all equipment referenced in this document which is manufactured by Graco and bearing its name to be free from defects in material and workmanship on the date of sale to the original purchaser for use. With the exception of any special, extended, or limited warranty published by Graco, Graco will, for a period of twelve months from the date of sale, repair or replace any part of the equipment determined by Graco to be defective. However, any deficiency in the barrel, handle, trigger, hook, internal power supply, and alternator (excluding turbine bearings) will be repaired or replaced for thirty-six months from the date of sale. This warranty applies only when the equipment is installed, operated and maintained in accordance with Graco's written recommendations.

This warranty does not cover, and Graco shall not be liable for general wear and tear, or any malfunction, damage or wear caused by faulty installation, misapplication, abrasion, corrosion, inadequate or improper maintenance, negligence, accident, tampering, or substitution of non-Graco component parts. Nor shall Graco be liable for malfunction, damage or wear caused by the incompatibility of Graco equipment with structures, accessories, equipment or materials not supplied by Graco, or the improper design, manufacture, installation, operation or maintenance of structures, accessories, equipment or materials not supplied by Graco.

This warranty is conditioned upon the prepaid return of the equipment claimed to be defective to an authorized Graco distributor for verification of the claimed defect. If the claimed defect is verified, Graco will repair or replace free of charge any defective parts. The equipment will be returned to the original purchaser transportation prepaid. If inspection of the equipment does not disclose any defect in material or workmanship, repairs will be made at a reasonable charge, which charges may include the costs of parts, labor, and transportation.

THIS WARRANTY IS EXCLUSIVE, AND IS IN LIEU OF ANY OTHER WARRANTIES, EXPRESS OR IMPLIED, INCLUDING BUT NOT LIMITED TO WARRANTY OF MERCHANTABILITY OR WARRANTY OF FITNESS FOR A PARTICULAR PURPOSE.

Graco's sole obligation and buyer's sole remedy for any breach of warranty shall be as set forth above. The buyer agrees that no other remedy (including, but not limited to, incidental or consequential damages for lost profits, lost sales, injury to person or property, or any other incidental or consequential loss) shall be available. Any action for breach of warranty must be brought within two (2) years of the date of sale.

GRACO MAKES NO WARRANTY, AND DISCLAIMS ALL IMPLIED WARRANTIES OF MERCHANTABILITY AND FITNESS FOR A PARTICULAR PURPOSE, IN CONNECTION WITH ACCESSORIES, EQUIPMENT, MATERIALS OR COMPONENTS SOLD BUT NOT MANUFACTURED BY GRACO. These items sold, but not manufactured by Graco (such as electric motors, switches, hose, etc.), are subject to the warranty, if any, of their manufacturer. Graco will provide purchaser with reasonable assistance in making any claim for breach of these warranties.

In no event will Graco be liable for indirect, incidental, special or consequential damages resulting from Graco supplying equipment hereunder, or the furnishing, performance, or use of any products or other goods sold hereto, whether due to a breach of contract, breach of warranty, the negligence of Graco, or otherwise.

FOR GRACO CANADA CUSTOMERS

The Parties acknowledge that they have required that the present document, as well as all documents, notices and legal proceedings entered into, given or instituted pursuant hereto or relating directly or indirectly hereto, be drawn up in English. Les parties reconnaissent avoir convenu que la rédaction du présent document sera en Anglais, ainsi que tous documents, avis et procédures judiciaires exécutés, donnés ou intentés, à la suite de ou en rapport, directement ou indirectement, avec les procédures concernées.

Graco Information

For the latest information about Graco products, visit www.graco.com. For patent information, see www.graco.com/patents.

To place an order, contact your Graco Distributor or call to identify the nearest distributor.

Phone: 612-623-6921 **or Toll Free:** 1-800-328-0211 **Fax:** 612-378-3505

All written and visual data contained in this document reflects the latest product information available at the time of publication.

Graco reserves the right to make changes at any time without notice.

For patent information, see www.graco.com/patents.

Original Instructions. This manual contains English, MM 3A2499

Graco Headquarters: Minneapolis

International Offices: Belgium, China, Japan, Korea

GRACO INC. AND SUBSIDIARIES • P.O. BOX 1441 • MINNEAPOLIS, MN 55440-1441 • USA

Copyright 2019, Graco Inc. All Graco manufacturing locations are registered to ISO 9001.

www.graco.com

Revision D, October 2021