

RTX1400, RTX2000 & RTX2500 Interior Texture Sprayers

3A3258H

EN

For water-based materials only. For professional use only.

Models: RTX1400si, RTX2000pi & RTX2500pi

70 psi (4.8 bar, 0.48 MPa) Maximum Working Pressure

100 psi (6.9 bar, 0.69 MPa) Maximum Working Pressure (RTX2500pi)



Important Safety Instructions

Read all warnings and instructions in this manual and related manuals.
Be familiar with the controls and the proper usage of the equipment.
Save these instructions.

Related Manuals

RTX1400si 120V Gun – 311777

RTX1400si 230V, RTX2000pi & RTX2500pi Gun – 3A3373

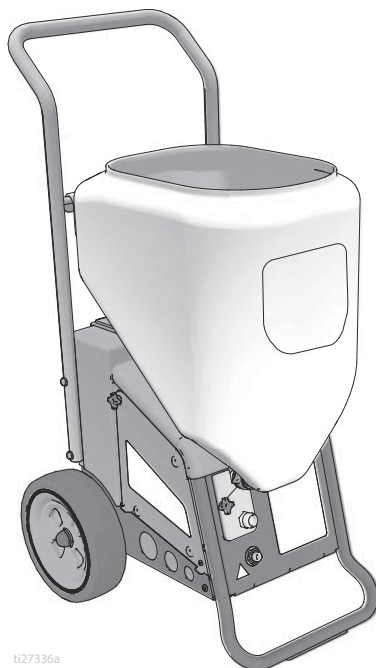

ti27336a





Use only genuine Graco replacement parts.

The use of non-Graco replacement parts may void warranty.

Contents

Models	3
Warnings	4
Component Identification	7
RTX1400si	7
RTX2000pi & RTX2500pi	8
Preparation	9
Pressure Relief Procedure	9
Grounding	9
Power Requirements	9
Extension Cords	9
Auxiliary Air Compressor	10
Generator Requirements	10
Soft Start/Smart Start™ System (RTX2000pi and RTX2500pi only)	10
Setup	11
Mixing Material	13
Operation	15
Texture Spraying	15
Recommended Nozzle Selection Charts	15
Adjusting the System	15
Shutdown and Cleanup	17
Clean Material Hopper	18
Transporting Sprayer	19
Maintenance	20
Texture Hoses	20
Tips	20
Caring for Sprayer	20
Troubleshooting	21
RTX1400si Sprayer	24
RTX1400si Sprayer Parts List	26
RTX2000pi Sprayer	27
RTX2000pi Sprayer Parts List	29
RTX2500pi Sprayer	30
RTX2500pi Sprayer Parts List	32
Compressor Parts	33
Compressor Parts List	34
Gun & Hose	35
RTX1400si 120V	35
RTX1400si 230V, RTX2000pi and RTX2500pi	35
Wiring Diagram	36
RTX1400si - 120V / RTX1400si - 230V	36
RTX2000pi and RTX2500pi	36
Wiring Diagram	37
RTX2500pi - 230V	37
Technical Specifications	38
Graco Standard Warranty	40
Graco Information	40

Models

	VAC	Model	
 Intertek 110474 Certified to CAN/CSA C22.2 No. 68 Conforms to UL 1450	120 USA	RTX1400si	17H572
		RTX1400si RentalHD	17P189
		RTX2000pi	17H573
	120 USA	RTX2000pi Rental	17H574
		RTX2000pi RentalHD	17K301
		RTX2500pi	17U219
230 AP	RTX2500pi Rental	17U220	
	RTX2500pi Rental HD	17U221	
	RTX1400pi	17X738	
	230 AP SCA Europe	RTX2500pi	17V582

Warnings

The following warnings are for the setup, use, grounding, maintenance, and repair of this equipment. The exclamation point symbol alerts you to a general warning and the hazard symbols refer to procedure-specific risks. When these symbols appear in the body of this manual or on warning labels, refer back to these Warnings. Product-specific hazard symbols and warnings not covered in this section may appear throughout the body of this manual where applicable.

WARNING



GROUNDING

This product must be grounded. In the event of an electrical short circuit, grounding reduces the risk of electric shock by providing an escape wire for the electric current. This product is equipped with a cord having a grounding wire with an appropriate grounding plug. The plug must be plugged into an outlet that is properly installed and grounded in accordance with all local codes and ordinances.

- Improper installation of the grounding plug is able to result in a risk of electric shock.
- When repair or replacement of the cord or plug is required, do not connect the grounding wire to either flat blade terminal.
- The wire with insulation having an outer surface that is green with or without yellow stripes is the grounding wire.
- Check with a qualified electrician or serviceman when the grounding instructions are not completely understood, or when in doubt as to whether the product is properly grounded.
- Do not modify the plug provided; if it does not fit the outlet, have the proper outlet installed by a qualified electrician.
- This product is for use on a nominal 120V or 230V circuit and has a grounding plug similar to the plugs illustrated below.

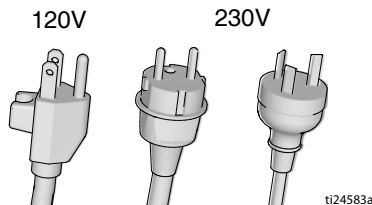









- Only connect the product to an outlet having the same configuration as the plug.
- Do not use an adapter with this product.

Extension Cords:

- Use only a 3-wire extension cord that has a grounding plug and a grounding receptacle that accepts the plug on the product.
- Make sure your extension cord is not damaged. If an extension cord is necessary use 12 AWG (2.5mm²) minimum to carry the current that the product draws.
- An undersized cord results in a drop in line voltage and loss of power and overheating.

WARNING

  	<p>FIRE AND EXPLOSION HAZARD</p> <p>Flammable fumes, such as solvent and paint fumes, in work area can ignite or explode. To help prevent fire and explosion:</p> <ul style="list-style-type: none"> • Do not spray or clean with flammable materials. Use water-based materials only. • Use equipment only in well ventilated area. • Sprayer generates sparks. When flammable liquids are used near the sprayer, keep sprayer at least 20 feet (6.1 meters) away from explosive vapors. • Keep work area free of debris, including solvent, rags and gasoline. • Ground all equipment in the work area. See Grounding instructions. • Keep a working fire extinguisher in the work area.
 	<p>EQUIPMENT MISUSE HAZARD</p> <p>Misuse can cause death or serious injury.</p> <ul style="list-style-type: none"> • Always wear appropriate gloves, eye protection, and a respirator or mask when painting. • Do not operate or spray near children. Keep children away from equipment at all times. • Do not overreach or stand on an unstable support. Keep effective footing and balance at all times. • Stay alert and watch what you are doing. • Do not operate the unit when fatigued or under the influence of drugs or alcohol. • Do not kink or over-bend the material or air hoses. • Do not expose the hose to temperatures or to pressures in excess of those specified by Graco. • Do not use the hose as a strength member to pull or lift the equipment. • Do not alter or modify equipment. Alterations or modifications may void agency approvals and create safety hazards. • Make sure all equipment is rated and approved for the environment in which you are using it.
	<p>BURN HAZARD</p> <p>Equipment surfaces and fluid that is heated can become very hot during operation. To avoid severe burns:</p> <ul style="list-style-type: none"> • Do not touch hot fluid or equipment.
 	<p>ELECTRIC SHOCK HAZARD</p> <p>This equipment must be grounded. Improper grounding, setup, or usage of the system can cause electric shock.</p> <ul style="list-style-type: none"> • Turn off and disconnect power cord before servicing equipment. • Connect only to grounded electrical outlets. • Use only 3-wire extension cords. • Ensure ground prongs are intact on power and extension cords. • Do not expose to rain. Store indoors.

Warnings

WARNING

PRESSURIZED EQUIPMENT HAZARD



Fluid from the equipment, leaks, or ruptured components can splash in the eyes or on skin and cause serious injury.



- Follow the **Pressure Relief Procedure** when you stop spraying/dispensing and before cleaning, checking, or servicing equipment.
- Tighten all fluid connections before operating the equipment.
- Check hoses, tubes, and couplings daily. Replace worn or damaged parts immediately.

MOVING PARTS HAZARD



Moving parts can pinch, cut, or amputate fingers and other body parts.



- Keep clear of moving parts.
- Do not operate equipment with protective guards or covers removed.
- Pressurized equipment can start without warning. Before checking, moving, or servicing equipment, follow the **Pressure Relief Procedure** and disconnect all power sources.

PLASTIC PARTS CLEANING SOLVENT HAZARD



Many solvents can degrade plastic parts and cause them to fail, which could cause serious injury or property damage.



- Use only compatible water-based solvents to clean plastic structural or pressure-containing parts.
- See **Technical Data** in this and all other equipment instruction manuals. Read fluid and solvent manufacturer's Safety Data Sheet (SDS) and recommendations.

PERSONAL PROTECTIVE EQUIPMENT



Wear appropriate protective equipment when in the work area to help prevent serious injury, including eye injury, hearing loss, inhalation of toxic fumes, and burns. This protective equipment includes but is not limited to:

- Protective eyewear, and hearing protection.
- Respirators, protective clothing, and gloves as recommended by the fluid and solvent manufacturer.

CALIFORNIA PROPOSITION 65

This product contains a chemical known to the State of California to cause cancer, birth defects or other reproductive harm. Wash hands after handling.

Component Identification

RTX1400si

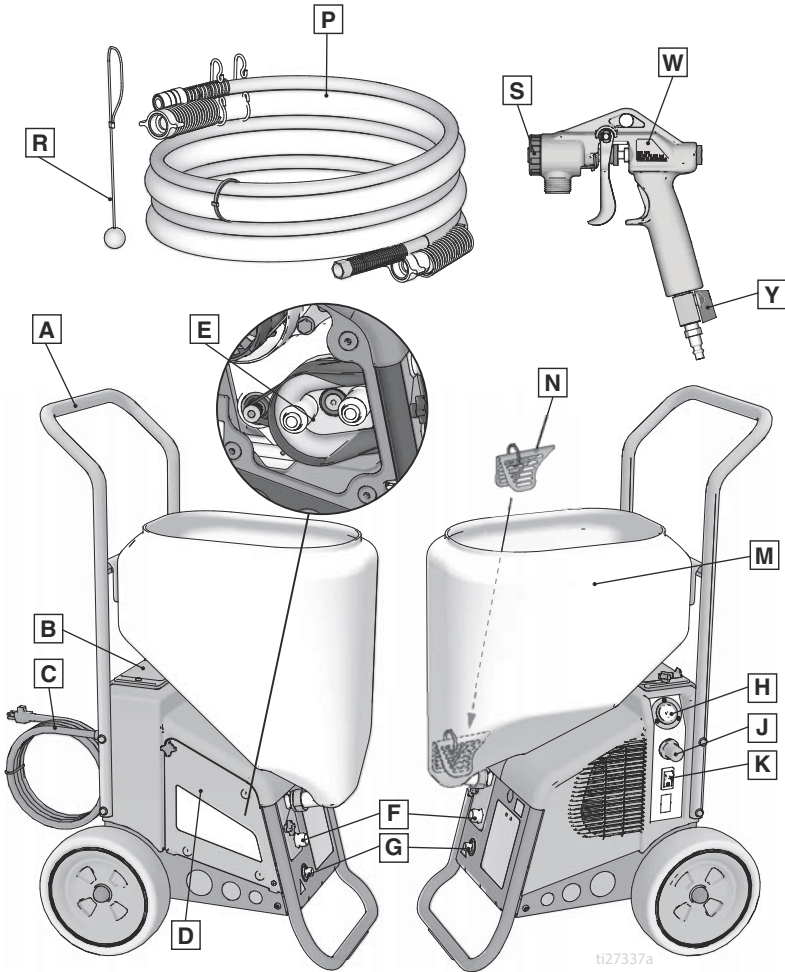

ti27337a

A	Handle
B	Toolbox
C	Power Cord
D	Pump Access Panel
E	RotoFlex™ II Pump
F	Pump Hose Outlet
G	Air Hose Outlet
H	Material Flow Gauge
J	Material Flow Control

K	ON/OFF Switch
M	Material Hopper
N	Burp Guard
P	Material/Air Hose
R	Material Thickness Gauge
S	Nozzle
W	Gun
Y	Air control valve
	Model/Serial Tag (Not shown, located on bottom of unit.)

Component Identification

RTX2000pi & RTX2500pi

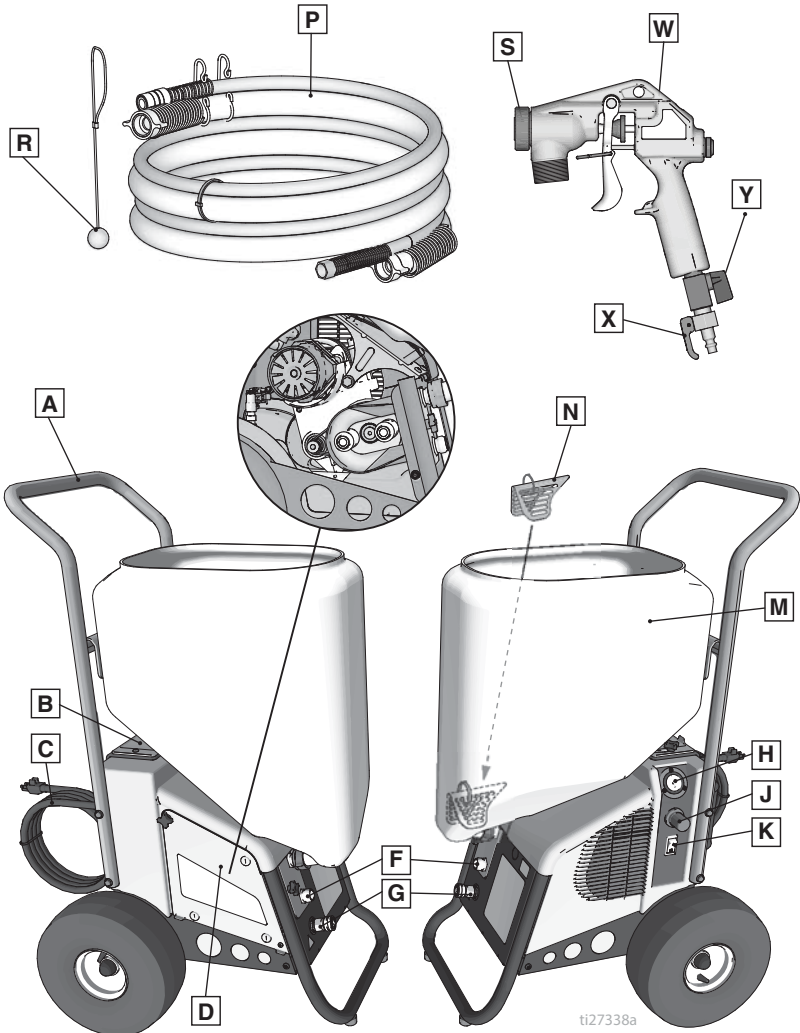

A	Handle
B	Toolbox
C	Power Cord
D	Pump Access Panel
E	RotoFlex™ II Pump
F	Pump Hose Outlet
G	Air Hose Outlet
H	Material Flow Gauge
J	Material Flow Control
K	ON/OFF Switch

M	Material Hopper
N	Burp Guard
P	Material/Air Hose
R	Material Thickness Gauge
S	Nozzle & retaining ring
W	Gun
X	Prime Valve
Y	Air control valve
	Model/Serial Tag (Not shown, located on bottom of unit.)

Preparation

Pressure Relief Procedure



Follow the Pressure Relief Procedure whenever you see this symbol.



This equipment stays pressurized until pressure is manually relieved. To help prevent serious injury from pressurized fluid or splashed fluid follow the **Pressure Relief Procedure** whenever sprayer is stopped and before sprayer is cleaned or checked, and before equipment is serviced.

1. Turn ON/OFF switch to the **OFF** position. Wait 7 seconds for power to dissipate.

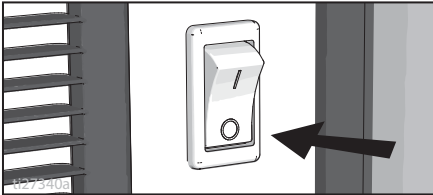

2. On the RTX1400si, trigger gun into material hopper.



3. Open air control valve.

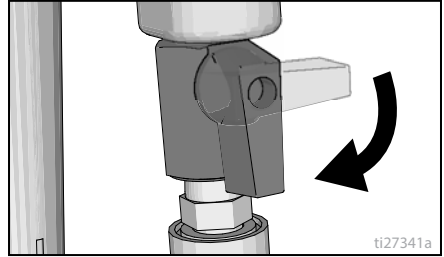

4. On the RTX2000pi and RTX2500pi, open gun prime valve.

Grounding



The equipment must be grounded to reduce the risk of static sparking and electric shock. An electric or static spark can cause fumes to ignite or explode. An improper ground can cause electric shock. A good ground provides an escape wire for the electric current.

This sprayer includes a ground wire with an appropriate ground contact. The plug must be plugged into an outlet that is properly installed and grounded in accordance with all local codes and ordinances.

Do not modify the plug provided; if it does not fit the outlet, have the proper outlet installed by a qualified electrician.

Power Requirements

100-120V units require 100-120 VAC, 50/60 Hz, 12 or 15A, 1 phase. 230V units require 220-240 VAC, 50/60 Hz, 10A

Extension Cords

Use an extension cord with an undamaged ground contact. If an extension cord is necessary, use a 3-wire, 12 AWG (2.5 mm²) minimum.

Preparation

NOTE: Lighter gauge or longer extension cords may reduce sprayer performance.

Auxiliary Air Compressor

Do not use an auxiliary air compressor with this spray system.

Generator Requirements

3500 W (3.5 kW) minimum.

Hose Size and Length

The system comes with a 25 ft (7.6m) hose set consisting of a 3/4 in. ID RTX1400si/1 in. ID RTX2000pi and RTX2500pi material hose and a 3/8 in-ID air hose.

Do not use more than 25 ft (7.6 m) of material hose.

Soft Start/Smart Start™ System (RTX2000pi and RTX2500pi only)

“Smart” vs. “Soft”

- “Smart” refers to the function where the motor starts and stops when the trigger is pulled and released. This keeps the sprayer at full operating pressure and allows the sprayer to spray immediately when the gun is triggered.

- “Soft” refers to the function where the sprayer slowly starts the pump. This prevents a large “splotch” of material from being discharged from the gun when trigger is pulled after the sprayer has sat idle for a period of time.

Smart Start

The Smart Start System is controlled by compressed air in the tanks and lines. When gun is triggered, air flows through the lines and opens a flow switch. There is also another pressure switch that senses when the compressed air system is at operating pressure. This second pressure switch allows the sprayer to start immediately when the sprayer is turned ON charging the compressed air system to full pressure. This method keeps the compressed air system at operating pressure if there is a small air leak in the system.

Soft Start

The Soft Start System is controlled by motor power and an air cylinder. When pressurized, the air cylinder pushes the rollers into the peristaltic pump pushing material through the pump. When the motor shuts off, a solenoid valve relieves the pressure in the air cylinder causing the rollers to disengage from the peristaltic pump. When the motor starts again there is a time delay while the air cylinders charge and move the rollers into the pump this is the “Soft Start”.

Setup

**NOTICE**

- Do not store sprayer under pressure.
- Do not allow material to dry inside pump, hoses, gun or spray system.
- When operating a RTX1400SI and you are going to stop spraying for more than five minutes turn sprayer OFF to prevent shortened pump life.

1. Connect air hose and material hose to sprayer air and material hose outlets.

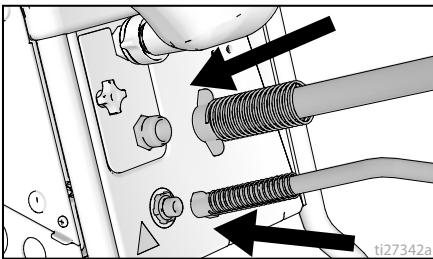

2. Open air valve.

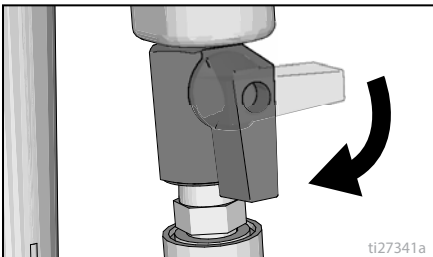

3. Connect air hose to gun.

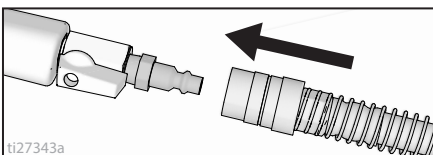

4. Connect material hose to gun.

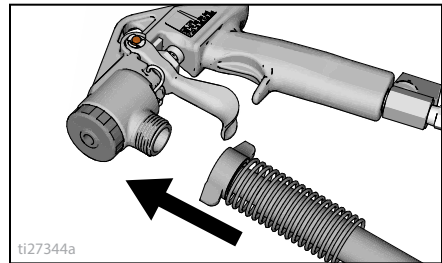

5. Make sure burp guard is installed.



Before adding material to the hopper, install the burp guard. When only a small amount of material remains in the hopper, the burp guard prevents material from shooting out when the unit is turned off. This material could splash in the operator's eyes or on skin, or into the air.

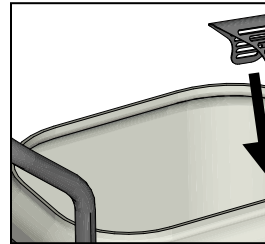

6. Install spray nozzle or wide spray disc. See **Recommended Nozzle Selection Charts**, page 15.

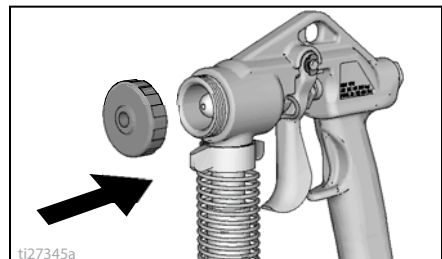

Setup

7. Pour one gallon (four liters) of water into the material hopper.

NOTICE

To prevent pump damage, before adding material or starting unit in cold weather, run warm water through the pump.

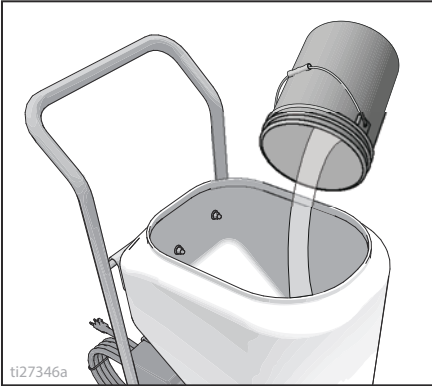

8. Turn ON/OFF switch to **ON** position.

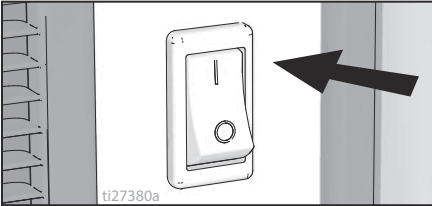

9. Close gun air valve. On the RTX2000pi and RTX2500pi, open the prime valve on the gun.

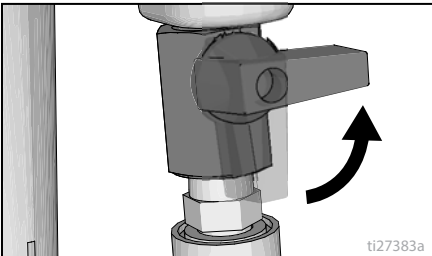

10. Point gun into waste bucket and pull trigger to pump water through the system. Continue to trigger gun until material hopper is empty.



11. Add pre-mixed texture mix to material hopper. See **Mixing Material**, page 13.

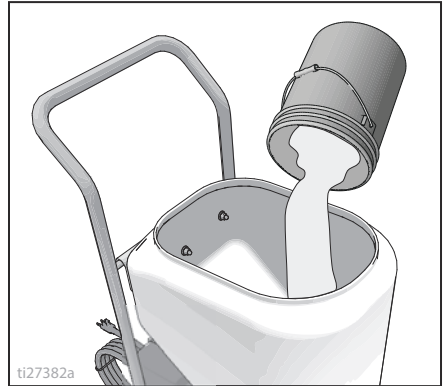

12. Continue to trigger gun and spray into waste bucket until a steady stream of material sprays out of gun.

13. Release trigger.

IMPORTANT! Fluid/air flow will be restricted if the material/air hoses are restricted or kinked.

Mixing Material



NOTE: Correct material mixture is essential. The pump will not operate if the mixture is too thick.

- Mix the material in a separate container before pouring it into hopper.
 - Use Material Thickness Gauge to determine if mixture is thin enough to spray.
 - The Material Thickness Gauge will only determine if the material is thin enough to pass through the pump. For some applications or for higher speed spraying, your mixture may need to be thinner.
 - For best results, do not use partial bags of material.
1. Mix the material and water in a separate container.

Dry Mix - 40 lb (18 kg) bag

Carefully mix texture material and water according to manufacturer instructions on bag.

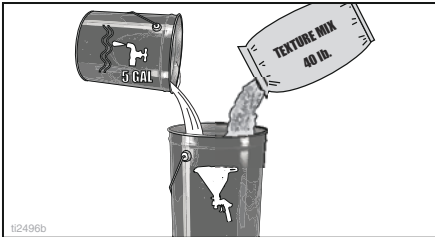

ti2496b

Premix

Slowly add approximately 2 to 4 quarts (1.9 to 3.8 liters) of water to a 5 gallon (18.9 liter) bucket of premix.

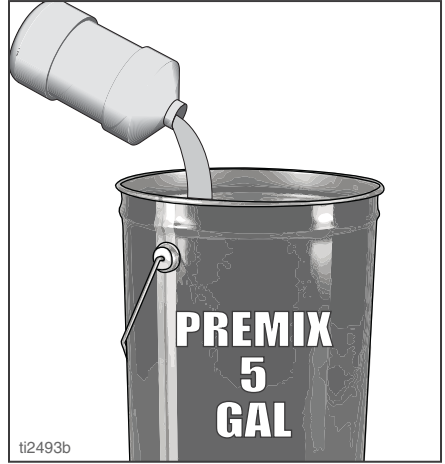

ti2493b

2. Agitate to mix, using a half-inch, variable speed drill with mixing paddle, to a smooth, lump-free consistency.



ti2497b

3. Allow ceiling texture to set for at least 15 minutes. Then remix prior to use.
4. After texture material is thoroughly mixed, gently set ball end of Material Thickness Gauge on surface of mixture.

Mixing Material

NOTE: For an accurate test, be sure gauge is completely dry and clean every time it is used.

5. Observe the ball on the material. When the material is thin enough to spray the ball will sink completely into the mixture within 10 seconds.

6. If the ball does not sink completely into the mixture within 10 seconds, add more water, agitate and try test again.
7. Once material is mixed pour material into the sprayer hopper. See **Operation**, page 15 for nozzle selection and sprayer adjustments.

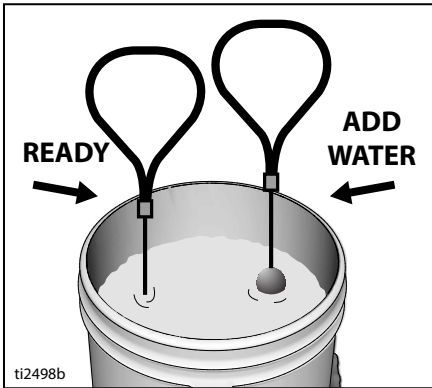

Operation

Texture Spraying

Recommended Nozzle Selection Charts

RTX1400si 120V

Application	Nozzle Size ²	Air Volume ¹
Simulated Acoustic	6 mm, white <i>(fine to medium)</i> 8 mm, gray <i>(coarse)</i>	medium to high
Orange peel	4 mm, beige, 6 mm, white	medium to high

¹Control air volume with gun air valve.

Application	Nozzle Size ²	Air Volume ¹
Spatter coat	6 mm, white 8 mm, gray	low to medium
Knockdown	6 mm, white 8 mm, gray 12 mm, black	low

²For more material volume try a larger nozzle.

RTX1400si 230V, RTX2000pi and RTX2500pi

Application	WideTex™ Disc		Nozzle (mm)	Air Volume
	Standard	Hardened		
Simulated Acoustic - Fine	W6	W6H	4	high
	W8	W8H	6	high
	W10	W10H	8- 10	high
Fog	W4	W4H	3	high
Orange peel	W4 or W6	W4H or W6H	3 - 8	medium to high
Spatter coat	W6 or W8	W6H or W8H	6 - 10	low to medium
Knockdown	W6 or W8	W6H or W8H	6 - 8	low

Adjusting the System

Sufficient fluid output (volume and pressure) and good atomization are a balance of atomizing air, material thickness/material flow and nozzle selection. Achieving the correct balance for your application requires experimentation to achieve desired results. Keep in mind these important points when adjusting gun:

- Select proper nozzle for your application. See Nozzle Selection Chart. Remember, the larger the nozzle, the heavier the pattern.
- Start sprayer with gun air flow valve completely open. Trigger sprayer gun. If needed, slowly close gun air flow until

you get a good spray pattern. Use minimum amount of air at spray gun to achieve proper spray pattern and to minimize bounce back.

+ Test spray pattern on cardboard. Hold gun 18 to 24 in. (45.7 to 61 cm) from surface. Use this spraying distance for most applications.

- Air and material flow adjustments are made at the gun on all units.

+ Opening air valve increases air flow through gun, which decreases texture material flow through pump.

+ Closing air valve decreases air flow through gun, which increases texture material flow through pump.

Operation

To achieve uniform spray pattern, adjust air valve and flow adjustment nut on gun. If you do not achieve the desired pattern, change nozzles, see **Recommended Nozzle Selection Charts**, page 15.

To Get Less Material

Try one or a combination of these methods:

- Open air valve.
- Turn gun flow adjustment nut counter-clockwise to decrease flow.
- Use smaller nozzle.

To Get More Material

Try any one or a combination of these methods:

- Close air valve.
- Turn gun flow adjustment nut clockwise to increase flow.
- Use thinner material mixture.
- Use a larger nozzle.

For Continuous Spraying

Use trigger lock to hold trigger open and reduce fatigue.

Check Material Consistency Periodically

Check and thin material as needed to maintain proper consistency. The material may thicken as it sits and slow down production. Agitate periodically.

Preventing Material Surge at Gun Trigger (RTX1400si only)

Pressure will build up in the system when you stop triggering the gun. To prevent material surge at initial gun triggering:

- Point gun away from surface you are spraying when you first pull trigger.

- When you first start to spray, hold the gun away from the surface and gradually work your way closer to it.
- Keep gun moving.
- After you begin spraying, trigger the gun as little as possible.

Soft Start/Smart Start Operation RTX2000pi and RTX2500pi

Smart Start

Sprayer will start under the following conditions:

- A new sprayer is plugged in and ON/OFF switch is turned **ON**.
- Gun is triggered and air valve is open far enough.
- There is a small leak in the system and the pressure drops below the pressure switch setting. This may appear to be random operation.
- When a bleeder gun is used.
- When there is no gun or hose connected to the sprayer.
- When the pressure is relieved by triggering the gun while the sprayer is OFF and then turned back ON.
- Prime valve is opened.
- There is a hose failure (leak) in the twin line hose.

Soft Start

- The easiest way to tell if the Soft Start System is functional is to spray material.
- The system is operating properly when a small amount of material initially comes out of the gun when triggered and the volume of material slowly increases to full spray.

NOTE: Motor runs when gun is triggered. Sprayer is designed to stop pumping when gun trigger is released.

Shutdown and Cleanup



NOTE: Keep pump and hose clean when switching between simulated acoustic, knockdown and orange peel applications. A dirty pump can release particles of texture into the finish.

- To increase pump life, life turn power OFF when not spraying.
- Before removing material hose, perform **Pressure Relief Procedure**, page 9. Make certain there is no material in the hose.
- To keep sprayer in good operating condition, always clean it thoroughly and prepare it properly for storage.

When you have finished spraying:

1. Open gun air valve.

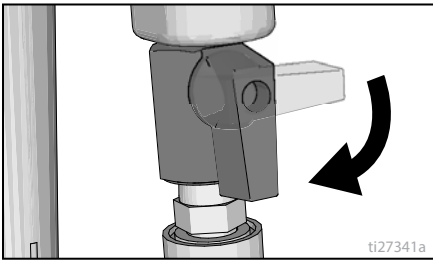

2. Turn ON/OFF switch to **ON** position.

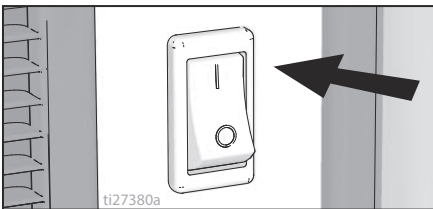

3. Close gun air valve.

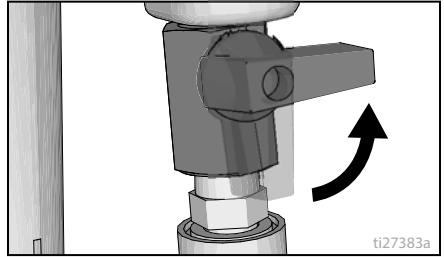

4. Trigger gun into bucket until most of texture mix is pumped out.



5. Fill material hopper with 2-4 gallons of clean water.

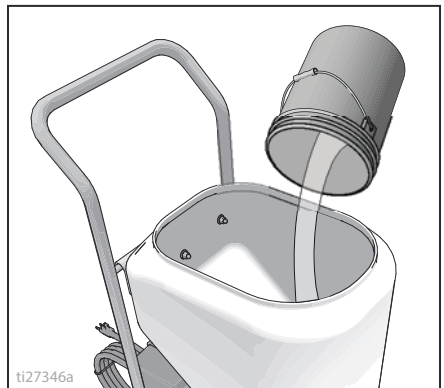

Shutdown and Cleanup

- Spray inside material hopper to circulate water through gun and hose. While circulating water, use gun to clean material hopper.



- Partially open gun air valve to use air to achieve better cleaning results.

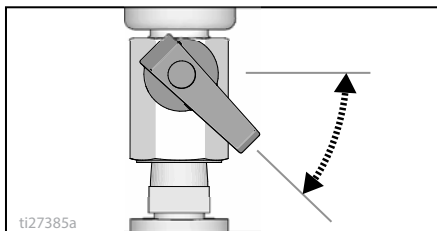

- Spray water into a waste bucket to empty material hopper.



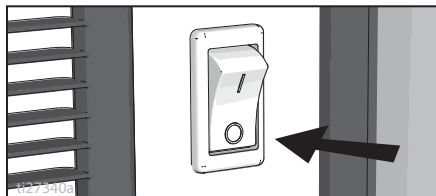

NOTE: A soft brush can be used to loosen dried on material.

- Turn ON/OFF switch to **OFF** position.



- Open gun air valve. Perform pressure relief procedure, **Pressure Relief Procedure**, page 9.

				
Air hose fittings can get hot. Allow sprayer to cool down 15 minutes before removing air hose.				

Clean Material Hopper

Material hopper can be removed for easy cleaning.

- Loosen bottom fitting

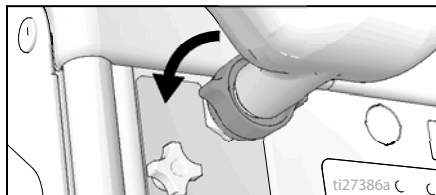

- Lift material hopper straight up, off the unit.

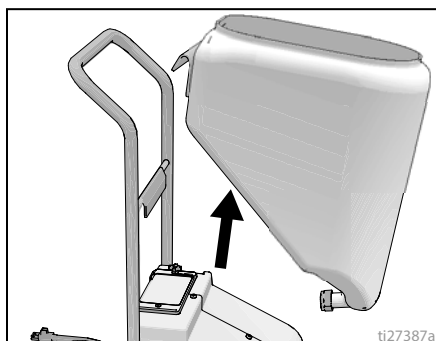

Shutdown and Cleanup

3. Plug opening on bottom of material hopper with your hand.

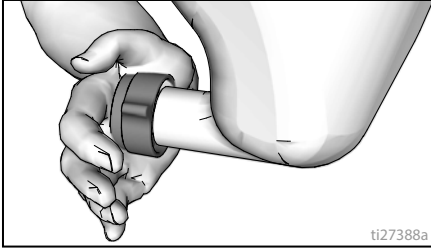

4. Take hopper to cleaning area for cleaning.
5. After cleaning material hopper, position it on sprayer handle first.

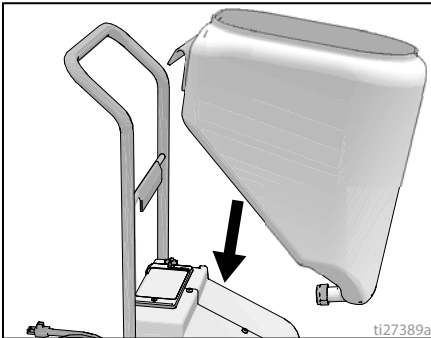

6. Hand tighten fitting.

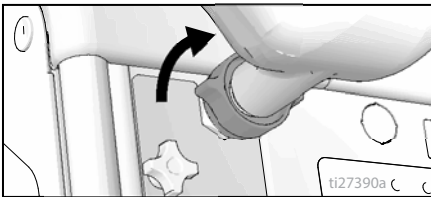

NOTICE

Water or material remaining in unit when temperatures are below freezing can damage motor and/or delay pump startup. Do not allow unit to freeze.

To ensure water and material are completely drained out of unit:

1. Remove material hose from sprayer.
2. Remove pump hose from sprayer. Empty hose and reinstall.
3. Remove hopper and drain.

Transporting Sprayer

The handle and hopper can be removed from the sprayer for storage or transporting.

NOTE: The handle on the RTX2000pi and RTX 2500pi has semi-permanent screws. It is not recommended that the handle be removed.

1. Remove hopper see **Clean Material Hopper**, page 18.
2. Loosen screws on either side of handle.
3. Spread handle apart and remove.

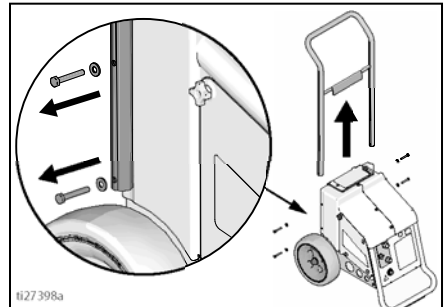

NOTICE

Do not lift sprayer by the handle. To prevent sprayer damage, handle should only be used to push or pull the sprayer.

Maintenance

Routine maintenance is important to ensure proper operation of your sprayer. Maintenance includes performing routine actions which keep your sprayer in operation and prevent trouble in the future.



Activity	Interval
Inspect motor shield vents for blockage.	Daily or each time you spray
Check sprayer stall (RTX2000pi and RTX2500pi only). With sprayer gun NOT triggered, sprayer motor should stall and not restart until gun is triggered again. If sprayer starts again with gun NOT triggered, inspect pump for internal/external leaks and check prime valve for leaks.	Every 1000 gallons (3785 liters)
Protect the internal drive parts of this sprayer from water. Openings in shields allow cooling of mechanical parts and electronics inside. If water gets into these openings, the sprayer could malfunction or be permanently damaged.	

Texture Hoses

Check hose for damage every time you spray. Do not attempt to repair hose if hose jacket or fittings are damaged. Do not use hoses shorter than 25 ft (7.6 m).

Tips

- Always clean tips with a soft brush after spraying.
- Tips may require replacement depending on abrasiveness of texture.

Troubleshooting



1. Follow **Pressure Relief Procedure**, page 9, before checking or repairing.
2. Check all possible problems and causes before disassembling the unit.

Problem	Cause	Solution
Sprayer won't run	Power switch not on	Turn switch on.
	No power at wall outlet	Check outlet by plugging in another appliance. If appliance does not work, try another outlet.
	Wrong size generator	Use a 3500 watt or larger generator. Refer to Generator Requirements, page 10.
	Circuit breaker tripped	Reset breaker.
Pump won't pump material	Air lock	Open air valve on gun.
	Mix too thick	Add water to thin material. Use Material Thickness Gauge.
	Loose fittings	Check and retighten all fittings.
	Plugged gun	Perform Pressure Relief Procedure , page 9. Remove gun from hose. Clean gun.
	Pump hose worn out	Replace hose. Recommended hose replacement - once every year.
	Pump cold	Move pump to warm room and allow it to warm up or run hot water through sprayer.
	Material flow turned down	Turn up material flow control.
Material runs out of bottom of sprayer	Pump hose worn out	Replace hose.
	Loose fittings	Check and retighten all fittings.
No air from compressor	Gun air valve closed	Open gun air valve.
	Low voltage	Check extension cord length and gauge. Replace if different than recommended. Refer to Grounding and Electrical Requirements, page 9.
	Gun needle plugged	Clean needle and retry.
	Worn compressor	Replace compressor. Contact a qualified Graco Service Center.
	Lines not connected	Check all quick disconnect connections to gun and hoses.
	Damaged hose.	Replace hose.

Troubleshooting

Problem	Cause	Solution
Speed of application slow or slower	Material too thick	Thin material.
	Nozzle too small	Change nozzles to a larger size. See Recommended Nozzle Selection Chart, page 15.
	Too much air being used.	Partially close gun air valve to reduce air flow.
	Pump hose worn	Replace hose.
	Plugged or dirty gun	Perform Pressure Relief Procedure , page 9. Clean gun.
	Kinked hose	Unkink hose.
	Gun adjustment set too low	Increase flow adjustment with flow adjustment nut.
	Too many items on same circuit	Unplug other items from circuit.
Intermittent flow/sputtering	Extension cord too long or wrong gauge	Use a different extension cord. Refer to Grounding and Electric Requirements, page 9.
	Hopper connection not tight	Check gasket. Tighten connection.
Quick disconnect does not stay connected.	Debris in system	Clean system.
	Dirty or corroded fitting	Clean thoroughly. Soak in oil. Apply a few drops of light oil.
Gun will not shut off	Worn nozzle or needle.	Perform Pressure Relief Procedure , page 9. Replace worn parts.
	Debris in needle passage	Perform Pressure Relief Procedure , page 9. Clean.
Fluid leaking at Flow Adjustment Nut	Damaged seal.	Perform Pressure Relief Procedure , page 9. Replace seal.
Needle adjustment won't adjust	Dirty threads	Clean threads.
	Nozzle not on gun	Put nozzle on gun.

Problem	Cause	Solution
Power switch is on and sprayer is plugged in, but motor does not run, and pump does not cycle.	Air valve on gun is closed or not open enough.	Open air valve.
	Motor or control is damaged.	Take sprayer to Graco authorized service center.
	Electric outlet is not providing power.	Try a different outlet or plug in something that you know is working to test outlet. Reset building circuit breaker or replace fuse.
	Extension cord is damaged.	Replace extension cord. See Grounding , page 9.
	Sprayer electric cord is damaged.	Check for broken insulation or wires. Replace electric cord if damaged.
	Material and/or water is frozen or hardened in pump.	Unplug sprayer from outlet. If frozen do NOT try to start sprayer until it is completely thawed or you may damage the motor, control board and/or drivetrain. Make sure power switch is OFF. Place sprayer in a warm area for several hours. Then plug in powercord and turn sprayer ON. Slowly increase pressure setting to see if motor will start. If material is hardened in sprayer, pump or pressure switch may need to be replaced. Take sprayer to Graco authorized service center.
	Prime valve is plugged (RTX2000pi and RTX2500pi).	Remove and clean prime valve.
Sprayer continues to run when gun trigger is released.	Gun is plugged.	Disassemble and clean gun.
	Pressure switch is damaged.	Replace pressure switch.
	Compressed air system leak.	Locate leak; check gun, twin line hose, or internal system. Reseal leaky fitting or replace hose.
Sprayer does not start when gun is triggered.	Flow switch is stuck.	Replace flow switch.
	Flow switch is stuck.	Replace flow switch.
Sprayer cycles ON and OFF when trigger is released. or Sprayer cycles ON and OFF when gun is triggered.	Pressure switch is damaged.	Replace pressure switch.
	Compressed air system leak.	Locate leak; check gun, twin line hose, or internal system. Reseal leaky fitting or replace hose.
	Flow switch is stuck.	Replace flow switch.
	Check valve is damaged.	Replace check valve.





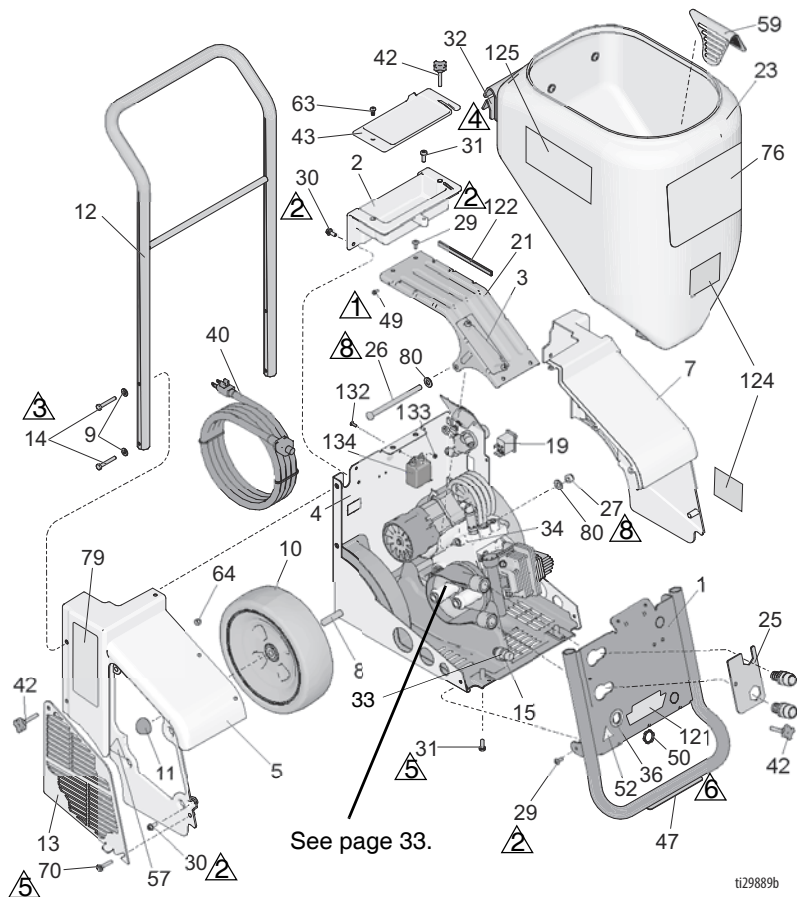

RTX1400si Sprayer

RTX1400si Sprayer

Ref.	Torque	Ref.	Torque
1	15-20 in-lb (1.7 - 2.3 N•m)	5	27-32 in-lb (3.1 - 3.6 N•m)
2	75-95 in-lb (8.5 - 10.7 N•m)	6	90-110 in-lb (10.2 - 12.4 N•m)
3	50-70 in-lb (5.6 - 7.9 N•m)	8	65-85 in-lb (7.3 - 9.6 N•m) then back off 1/4 turn
4	40-50 in-lb (4.5 - 5.6 N•m)		



RTX1400si Sprayer (cont'd)

Ref.	Torque	Ref.	Torque
	15-20 in-lb (1.7 - 2.3 N•m)		27-32 in-lb (3.1 - 3.6 N•m)
	75-95 in-lb (8.5 - 10.7 N•m)		90-110 in-lb (10.2 - 12.4 N•m)
	50-70 in-lb (5.6 - 7.9 N•m)		65-85 in-lb (7.3 - 9.6 N•m) then back off 1/4 turn
	40-50 in-lb (4.5 - 5.7 N•m)		

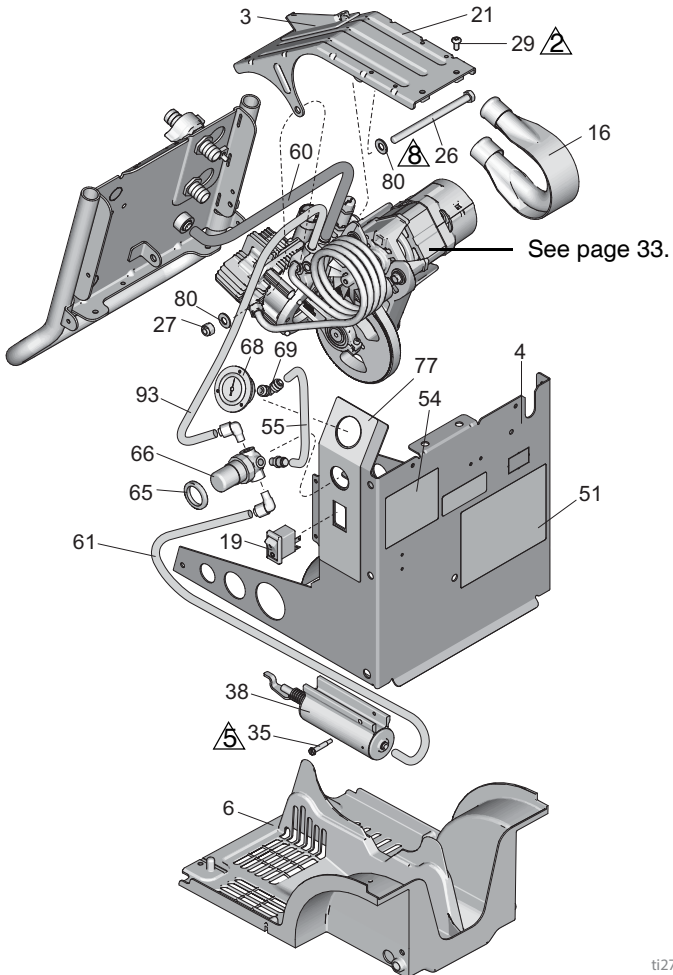

ti27872a

RTX1400si Sprayer

RTX1400si Sprayer Parts List

Ref. Part	Description	Qty.	Ref. Part	Description	Qty.
1	17U971	1	54	17J928	1
2	15J600	1	55	★	1
3	15H069	1	57▲	16M768	1
4	17H404	1	59	17H638	1
5	17K497	1	60	★	1
6	277319	1	61	★	1
7	15J672	1	63	111831	1
8	15J671	1	64	102040	1
9	110755	4	65	115244	1
10	17K546	2	66	117694	1
			68	117720	1
11	112612	2		<i>includes 69</i>	
12	17H418	1	69	120653	1
13	17K511	1			
14	102313	4	70	120444	1
15	288336	1	76		
				17H625	1
16	288623	1		17P190	1
19	120660	1	77	17H522	1
21	15H910	1	78	246013	1
23	17P499	1			
			79	17H627	1
25	17H410	1	80	120215	2
26	105240	1	93	★	1
27	113981	1	110	17X793	1
29	17W832	6	111	17X794	1
30	117633	3	121	17L030	1
31	120771	5	122	17L120	1
32	17H490	1	124	15E332	2
33	24Z003	1			
35	120236	1	125	17P191	1
	17B440	1	128	242005	1
36	120731	1	132	121803	2
38	289591	1			
40	16M501	1	133	115483	2
	17V511	1	134	116168	1
42	15J862	3	135	17W166	1
43	15D561	1			
47	120759	1	★	17L017	1
49	115498	2			
50	104227	1			
51▲	15H841	1			
▲	17V739	1			
52▲	15K616	1			

▲ Replacement Danger and Warning labels, tags, and cards are available at no cost.

RTX2000pi Sprayer

Ref.	Torque	Ref.	Torque
⚠ ₁	15-20 in-lb (1.7 - 2.3 N•m)	⚠ ₅	27-32 in-lb (3.1 - 3.6 N•m)
⚠ ₂	75-95 in-lb (8.5 - 10.7 N•m)	⚠ ₆	90-110 in-lb (10.2 - 12.4 N•m)
⚠ ₃	50-70 in-lb (5.6 - 7.9 N•m)	⚠ ₈	65-85 in-lb (7.3 - 9.6 N•m) then back off 1/4 turn
⚠ ₄	40-50 in-lb (4.5 - 5.7 N•m)	⚠ ₉	3-5 in-lb (0.34-0.56 N•m) Loctite 243

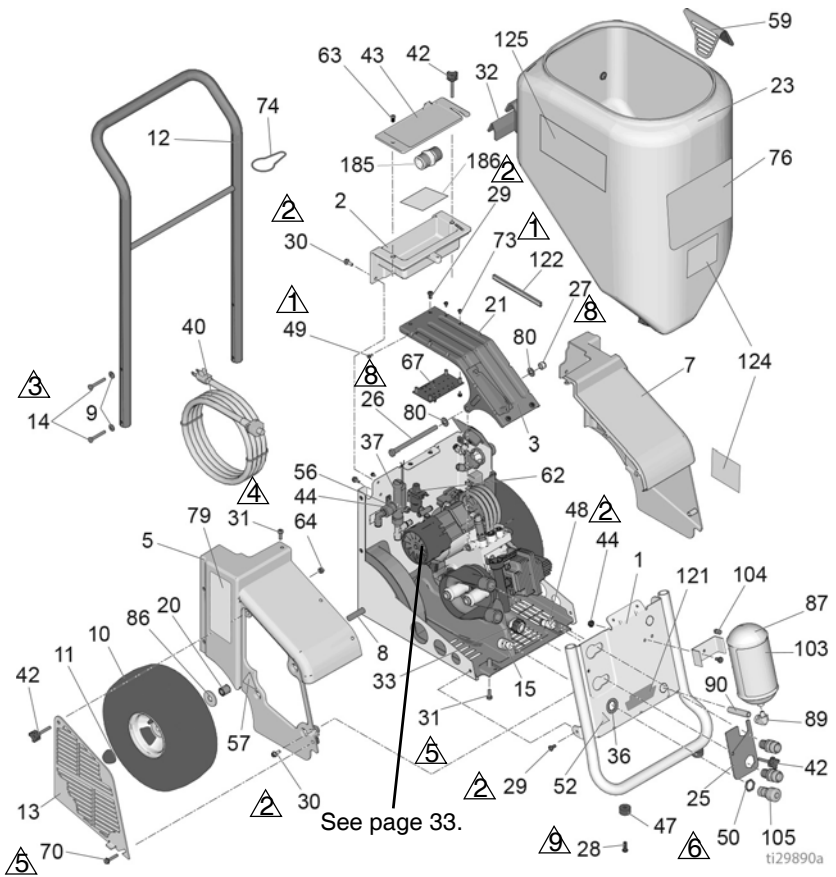

RTX2000pi Sprayer

RTX2000pi Sprayer (cont'd)

Ref.	Torque	Ref.	Torque
△1	15-20 in-lb (1.7 - 2.3 N•m)	△6	90-110 in-lb (10.2 - 12.4 N•m)
△2	75-95 in-lb (8.5 - 10.7 N•m)	△7	9-11 in-lb (1- 1.2 N•m)
△3	50-70 in-lb (5.6 - 7.9 N•m)	△8	65-85 in-lb (7.3 - 9.6 N•m) then back off 1/4 turn
△4	40-50 in-lb (4.5 - 5.7 N•m)	△9	120-130 in-lb (13.6 - 14.7 N•m)
△5	27-32 in-lb (3.1 - 3.6 N•m)		

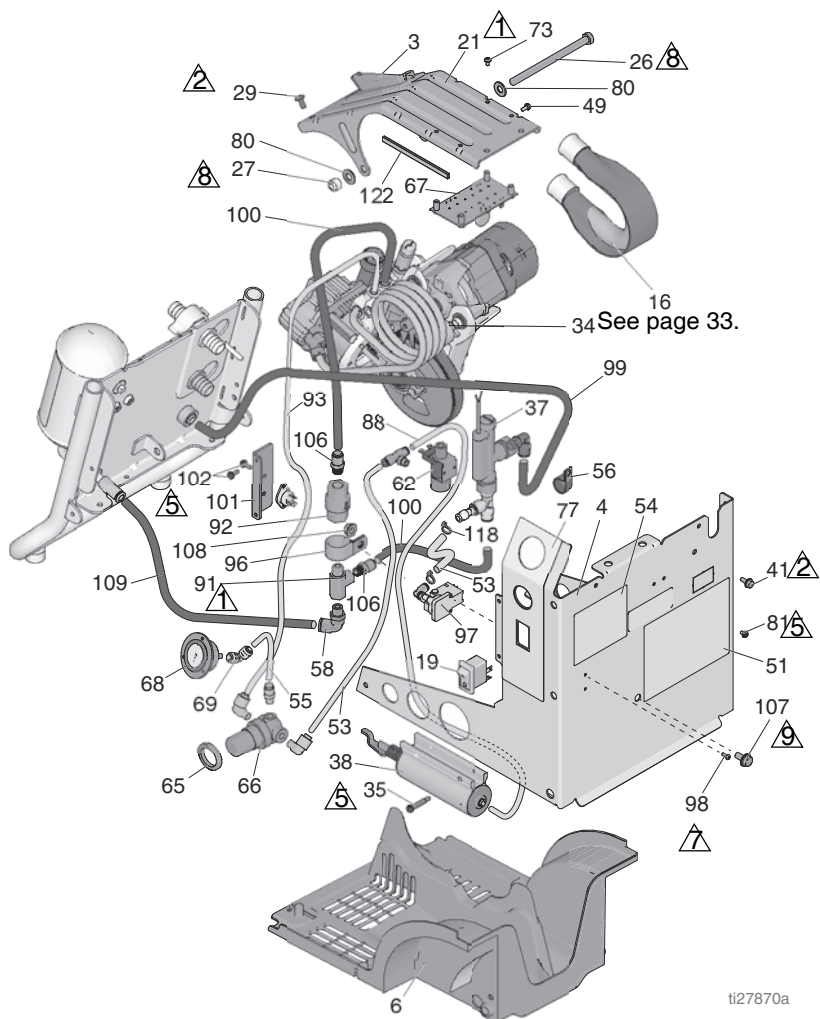

ti27870a

RTX2000pi Sprayer Parts List

Ref.	Part	Description	Qty.	Ref.	Part	Description	Qty.
1	17U971	FRAME, front	1	67	17K598	KIT, repair, circuit board <i>includes 73, 101, 102</i>	1
2	15J600	BOX, tool	1	68	117720	GAUGE, pressure, <i>includes 69</i>	1
3	15H069	SUPPORT, hopper	1	69	120653	FITTING, push to connect	1
4	17H404	FRAME, back	1	70	120444	SCREW, mach, pnhd	1
5	17K497	SHIELD, right	1	73	120743	SCREW, mach, pnhd	4
6	277319	SHIELD, bottom	1	74	121092	CLIP, spring, Model 17H574, 17K301	1
7	15J672	SHIELD, left	1	76		LABEL, hopper, RTX Model 17H573	1
8	17H429	AXLE	1		17J506	Model 17H574, 17K301	1
9	110755	WASHER, plain	4		17H626	LABEL, control	1
10	17K531	WHEEL, pneumatic	2	77	17H522	KIT, meter hour, Model 17H574, 17K301	1
11	112612	CAP, hub	2	78	246013	LABEL, side RTX	1
12	17H418	HANDLE, painted	1	79	17H627	WASHER, Belleville	2
13	17K511	DOOR, shield	1	80	120215	SCREW, mach, slot	2
14	102313	SCREW, cap, hex	4	81	17J525	WASHER, plain, wide	2
15	288336	FITTING, bulkhead	1	86	17K529	KIT, repair, accumulator tank <i>includes 44, 48, 89, 90, 103, 104</i>	1
16	288623	HOSE, coupled	1	87	17K593	TUBE, air, 0.250	1
19	120660	SWITCH, rocker	1	88	★	FITTING, elbow	1
20	17K530	SPACER, wheel	2	89	121150	NIPPLE, pipe	1
21	15H910	BRACKET, pump	1	90	100124	FITTING, tee	1
23	17P498	HOPPER, 13 gallon, <i>includes 32, 59</i>	1	91	116504	KIT, repair, check valve <i>includes 58, 91, 96, 106, 107, 108</i>	1
25	17H410	PLATE, hose	1	92	17K595	TUBE, air, 0.250	1
26	105240	SCREW, cap, hex, hd	1	93	★	CLAMP, loop	1
27	113981	NUT, lock	1	96	128051	KIT, repair, pressure switch <i>includes 53, 98, 118</i>	1
28	112689	SCREW, button, hd	2	97	17K596	SCREW, plastite	2
29	17W832	SCREW	6	98	117317	TUBE, air, 0.375	1
30	117633	SCREW, slot, hex	3	99	★	TUBE, air, 0.375	2
31	120771	SCREW, mach, pnhd	5	100	★	BRACKET, mounting	1
32	17H490	PAD, isolator	1	101	17J638	SCREW, mach, slot, hex	4
33	24Z003	ADAPTER, swivel	1	102	118444	LABEL, smart start	1
35	120236	SCREW, shoulder (Series A)	1	103	17J933	PLUG, pipe	1
	17B440	SCREW, shoulder (Series B)	1	104	100403	COUPLER, line, air	1
36	120731	WASHER, flat, thin	1	105	110198	FITTING, tube, straight	2
37	17K594	KIT, repair, flow switch <i>includes 41, 44, 53, 56, 118, 123</i>	1	106	17J393	SCREW, cap hex, hd	1
38	289591	CYLINDER, air, assy.	1	107	111800	NUT, hex, flange head	1
40	16M501	CORD, power	1	108	110996	TUBE, air, 0.375	2
41	108526	SCREW, mach	1	109	★	CLAMP, spring tube	2
42	15J862	KNOB	3	118	17L903	TUBE, air	1
43	15D561	COVER, tool tray	1	119	★	LABEL, pi models	1
44	115942	NUT, hex, flange head	3	121	17L028	GROMMET, edge	1
47	17J201	BUMPER, recessed	2	122	17L120	FITTING	1
48	16F710	CONNECTOR, 3/8	1	123		LABEL, Home Depot Tool Rental	2
49	115498	SCREW, mach, slot	2	124	15E332	LABEL, material mixing, Model 17K301	1
50	104227	NUT, lock	1	125	17P192	FITTING, nipple	1
51▲	15H841	LABEL, warning	1	185	15E359	LABEL, info	1
52▲	15K616	LABEL, caution	1	186	17X931	KIT, tube, air <i>includes 53, 55, 88, 93, 99, 100, 109, 119</i>	1
53	★	TUBE, air, 0.365	2	★	17L017		1
54	17H629	LABEL, instructions	1				
55	★	TUBE, air, 0.250	1				
56	120830	CLAMP, loop	1				
57▲	16M768	LABEL, warning	1				
58	121141	FITTING, elbow, swivel	1				
59	17H638	BAFFLE, hopper	1				
62	17K597	KIT, repair, solenoid valve <i>includes 81</i>	1				
63	111831	SCREW, skt, button	1				
64	102040	NUT, hex, lock	1				
65	115244	NUT, regulator	1				
66	117694	KIT, regulator, air	1				

▲ Replacement Danger and Warning labels, tags, and cards are available at no cost.

RTX2500pi Sprayer

RTX2500pi Sprayer

Ref.	Torque	Ref.	Torque
①	15-20 in-lb (1.7 - 2.3 N•m)	⑤	27-32 in-lb (3.1 - 3.6 N•m)
②	75-95 in-lb (8.5 - 10.7 N•m)	⑥	90-110 in-lb (10.2 - 12.4 N•m)
③	50-70 in-lb (5.6 - 7.9 N•m)	⑧	65-85 in-lb (7.3 - 9.6 N•m) then back off 1/4 turn
④	40-50 in-lb (4.5 - 5.7 N•m)	⑨	3-5 in-lb (0.34-0.56 N•m) Loctite 243

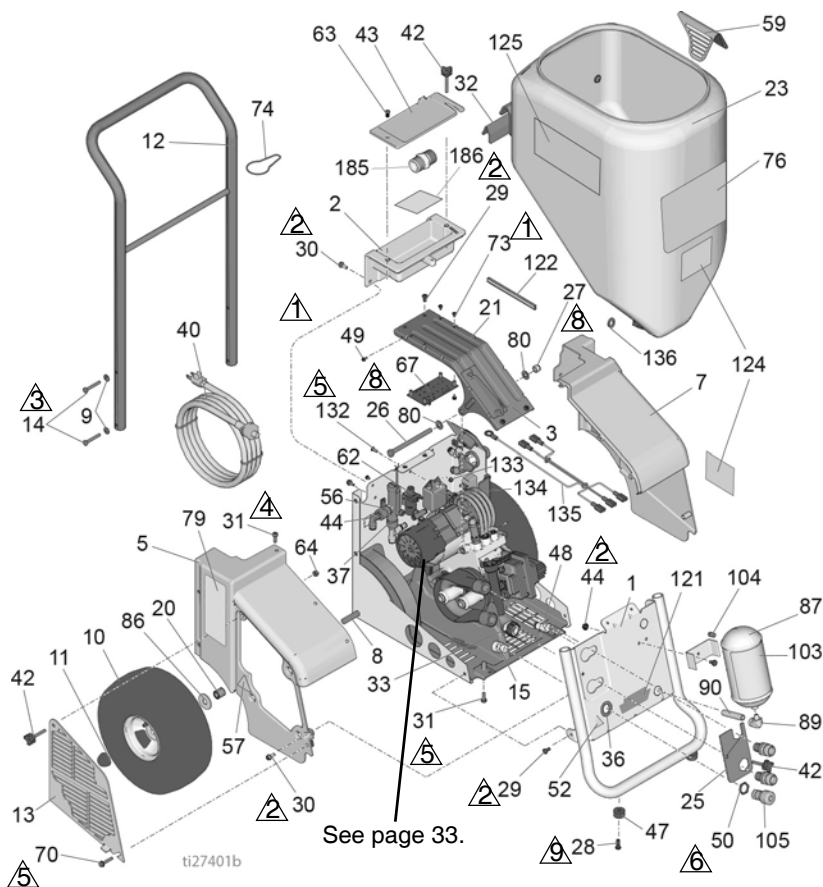

RTX2500pi Sprayer (cont'd)

Ref.	Torque	Ref.	Torque
⚠️ 1	15-20 in-lb (1.7 - 2.3 N•m)	⚠️ 6	90-110 in-lb (10.2 - 12.4 N•m)
⚠️ 2	75-95 in-lb (8.5 - 10.7 N•m)	⚠️ 7	9-11 in-lb (1- 1.2 N•m)
⚠️ 3	50-70 in-lb (5.6 - 7.9 N•m)	⚠️ 8	65-85 in-lb (7.3 - 9.6 N•m) then back off 1/4 turn
⚠️ 4	40-50 in-lb (4.5 - 5.7 N•m)	⚠️ 9	120-130 in-lb (13.6 - 14.7 N•m)
⚠️ 5	27-32 in-lb (3.1 - 3.6 N•m)		

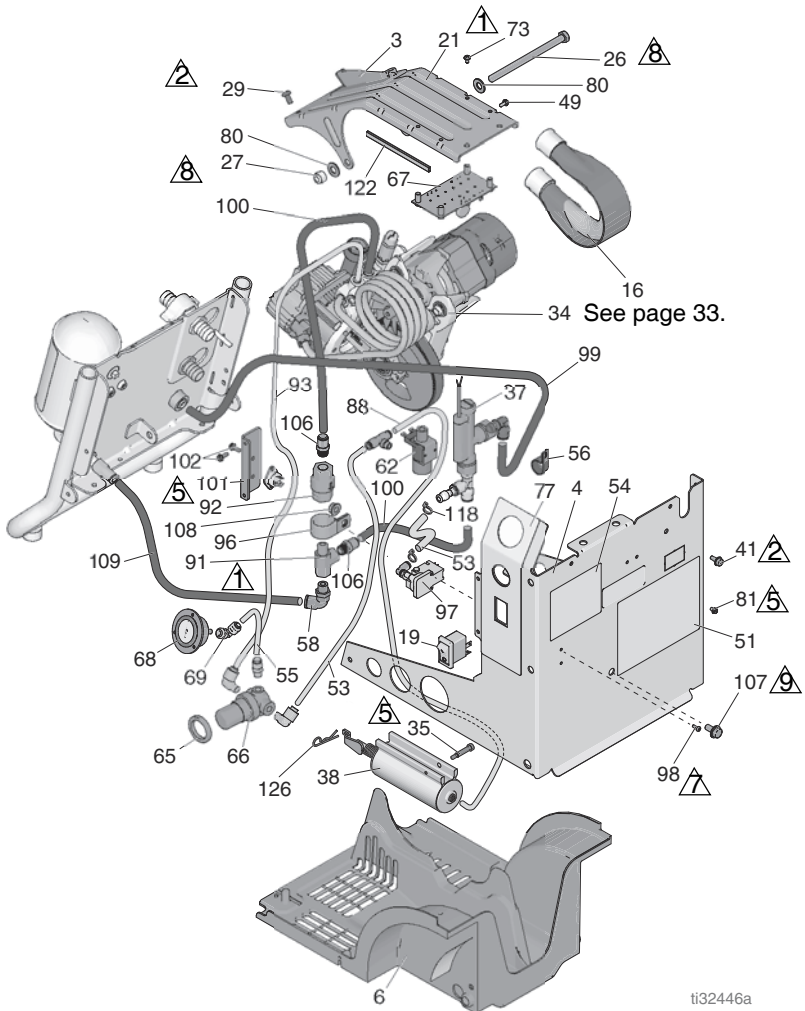









ti32446a

RTX2500pi Sprayer

RTX2500pi Sprayer Parts List

Ref.	Part	Description	Qty.	Ref.	Part	Description	Qty.
1	17U971	FRAME, front	1	68	117720	GAUGE, pressure, <i>includes 69</i>	1
2	15J600	BOX, tool	1	69	120653	FITTING, push to connect	1
3	15H069	SUPPORT, hopper	1	70	120444	SCREW, mach, pnhd	1
4	17H404	FRAME, back	1	73	120743	SCREW, mach, pnhd	4
5	17K497	SHIELD, right	1	74	121092	CLIP, spring, Model 17H574, 17K301	1
6	277319	SHIELD, bottom	1	76		LABEL, hopper, RTX	1
7	15J672	SHIELD, left	1		17U160	Model 17U219, 17V582	1
8	17H429	AXLE	1		17U814	Model 17U220, 17U221	1
9	110755	WASHER, plain	4	77	17H522	LABEL, control	1
10	17K531	WHEEL, pneumatic	2	78	246013	KIT, meter hour, Model 17U220, 17U221	1
11	112612	CAP, hub	2	79	17H627	LABEL, side RTX	1
12	17H418	HANDLE, painted	1	80	120215	WASHER, Belleville	2
13	17K511	DOOR, shield	1	81	17J525	SCREW, mach, slot	2
14	102313	SCREW, cap, hex	4	86	17K529	WASHER, plain, wide	2
15	288336	FITTING, bulkhead	1	87	17K593	KIT, repair, accumulator tank <i>includes 44, 48, 89, 90, 103, 104</i>	1
16	288623	HOSE, coupled	1	88	★	TUBE, air, 0.250	1
19	120660	SWITCH, rocker	1	89	121150	FITTING, elbow	1
20	17K530	SPACER, wheel	2	90	100124	NIPPLE, pipe	1
21	15H910	BRACKET, pump	1	91	116504	FITTING, tee	1
23	17V410	HOPPER, 15 gallon	1	92	17K595	KIT, repair, check valve <i>includes</i> <i>58, 91, 96, 106, 107, 108</i>	1
25	17H410	PLATE, hose	1	93	★	TUBE, air, 0.250	1
26	105240	SCREW, cap, hex, hd	1	96	128051	CLAMP, loop	1
27	113981	NUT, lock	1	97	17K596	KIT, repair, pressure switch <i>includes 53, 98, 118</i>	1
28	112689	SCREW, button, hd	2	98	117317	SCREW, plastite	2
29	17W832	SCREW, hex, hd	6	99	★	TUBE, air, 0.375	1
30	117633	SCREW, slot, hex	3	100	★	TUBE, air, 0.375	2
31	120771	SCREW, mach, pnhd	5	101	17J638	BRACKET, mounting	1
32	17H490	PAD, isolator	1	102	118444	SCREW, mach, slot, hex	4
33	24Z003	ADAPTER, swivel	1	103	17J933	LABEL, smart start	1
35	17B440	SCREW, shoulder	1	104	100403	PLUG, pipe	1
36	120731	WASHER, flat, thin	1	105	110198	COUPLER, line, air	1
37	17K594	KIT, repair, flow switch <i>includes</i> <i>41, 44, 53, 56, 118, 123</i>	1	106	17J393	FITTING, tube, straight	2
38	17U095	CYLINDER, air, assy.	1	107	111800	SCREW, cap hex, hd	1
40	16M501	CORD, power	1	108	110996	NUT, hex, flange head	1
	17V511	CORD, power 230V	1	109	★	TUBE, air, 0.375	2
41	108526	SCREW, mach	3	118	17L903	CLAMP, spring tube	2
42	15J862	KNOB	1	119	★	TUBE, air	1
43	15D561	COVER, tool tray	1	121	17L028	LABEL, pi models	1
44	115942	NUT, hex, flange head	3	122	17L120	GROMMET, edge	1
47	17J201	BUMPER, recessed	2	123		FITTING	1
48	16F710	CONNECTOR, 3/8	1	124	15E332	LABEL, Home Depot Tool Rental	2
49	115498	SCREW, mach, slot	2	125	17P192	LABEL, material mixing, Model 17K301	1
50	104227	NUT, lock	1	126	114814	PIN, cotter	1
51▲	15H841	LABEL, warning	1	127	242001	CORD SET, adapter, Europe, 230V	1
	17V739	LABEL, warning, ISO	1	128	242005	CORD SET, adapter, Aus., 230V	1
52▲	15K616	LABEL, caution	1	132	121803	SCREW, cap, button head, 230V	2
53	★	TUBE, air, 0.365	2	133	115483	NUT, lock, 230V	2
54	17H629	LABEL, instructions	1	134	116168	FILTER, EMI, 230V	1
55	★	TUBE, air, 0.250	1	135	17W166	HARNES, wire, EMI, 230V	1
56	120830	CLAMP, loop	1	136	17K793	GASKET	1
57▲	16M768	LABEL, warning	1	185	15E359	FITTING, nipple	1
58	121141	FITTING, elbow, swivel	1	186	17X931	LABEL, info	1
59	17H638	BAFFLE, hopper	1	★	17L017	KIT, tube, air <i>includes 53, 55, 88,</i> <i>93, 99, 100, 109, 119</i>	1
62	17K597	KIT, repair, solenoid valve <i>includes 81</i>	1	▲		Replacement Danger and Warning labels, tags, and cards are available at no cost.	
	24S144	KIT, repair, solenoid valve, 230V <i>includes 81</i>	1				
63	111831	SCREW, skt, button	1				
64	102040	NUT, hex, lock	1				
65	115244	NUT, regulator	1				
66	117694	KIT, regulator, air	1				
67	17K598	KIT, repair, circuit board <i>includes</i> <i>73, 101, 102</i>	1				
	17W421	KIT, repair, 230V circuit board <i>includes 73, 101, 102</i>	1				

Compressor Parts

Ref.	Torque	Ref.	Torque
	18-22 ft-lb (24.4 - 29.8 N•m)		50-65 in-lb (5.7 - 7.3 N•m)
	190-230 in-lb (21.5 - 26 N•m)		120-140 in-lb (13.6 - 15.8 N•m) Finger tighten cap screw in position 1 first. Then torque cap screws in 2, 3, 4, and 1 sequence illustrated.
	Piston retaining bolt & crankshaft bolts must be torqued before head bolts (30) are torqued.		Hand tighten, then 2 full turns
	60-72 in-lb (6.8 - 8.1 N•m)		Tension to 15-25 lb (66.7-111.2 N)

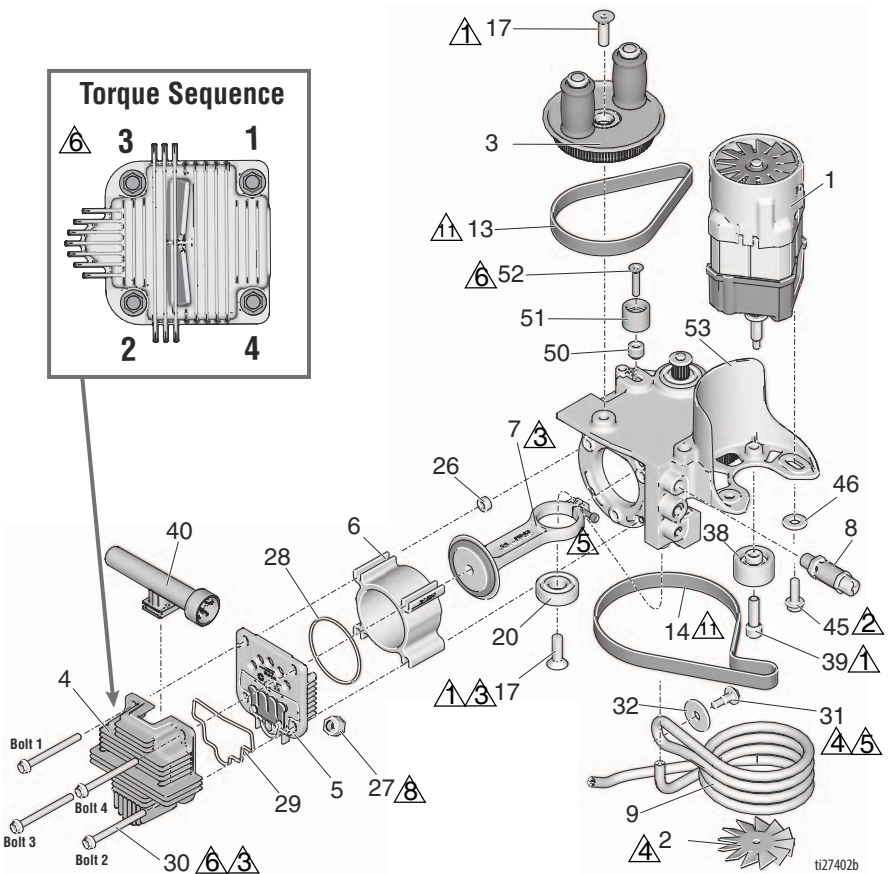
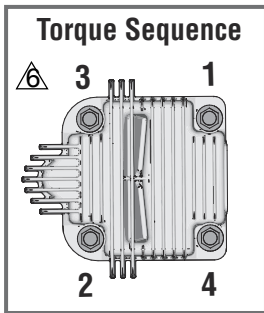

Compressor Parts

Compressor Parts List

Ref. Part	Description	Qty.	Ref. Part	Description	Qty.
24S128	KIT, repair, compressor, complete, 120V	1	14*	120233 BELT, 3mm, timing	1
17V643	KIT, repair, compressor, complete, 230V	1	17*	120204 SCREW, mach, hex	2
1 17K879	KIT, repair, motor, universal, 120V <i>includes 2, 14, 45, 46</i>	1	20*	120227 BEARING, ball	1
17V642	KIT, repair, motor, universal, 230V <i>includes 2, 14, 45, 46</i>	1	26*	17H525 SPACER, compressor	4
2 120466	FAN, motor	1	27	17H561 NUT, compression w/ sleeve	1
3 288616	PULLEY, with rollers <i>includes 13, 17</i>	1	28*	17H554 O-RING, square	1
4* 24S130	KIT, repair, head, compressor <i>includes 5, 28, 29</i>	1	29*	17H555 O-RING, formed square	1
5* 24S131	KIT, repair, plate, valve <i>includes 28, 29</i>	1	30*	17H560 SCREW, cap serrated flange head	4
6* 17H553	CYLINDER, compressor	1	31	119872 SCREW, shoulder	1
7* 24S132	KIT, repair, piston/cylinder <i>includes 5, 6, 17, 20, 28, 29</i>	1	32	120659 WASHER, flat	1
8 120617	VALVE, pressure relief	1	38	288611 KIT, repair, idler <i>includes 14, 39</i>	1
9 24S133	KIT, repair, cooler <i>includes 27</i>	1	39	C20021 SCREW, cap, skt head	1
13 120234	BELT, 3mm, timing	1	40*	17H657 MUFFLER, compressor	1
			45	260215 SCREW, hex head	2
			46	100023 WASHER, flat	2
			50	17L467 SPACER, idler	1
			51	17L470 PULLEY, idler, bearing pressed	1
			52	17L477 SCREW, mach, hex flat hd	1
			53	24E021 KIT, compressor, bracket	1
			*	24S129 KIT, repair, compressor, rebuild	

Gun & Hose

RTX1400si 120V

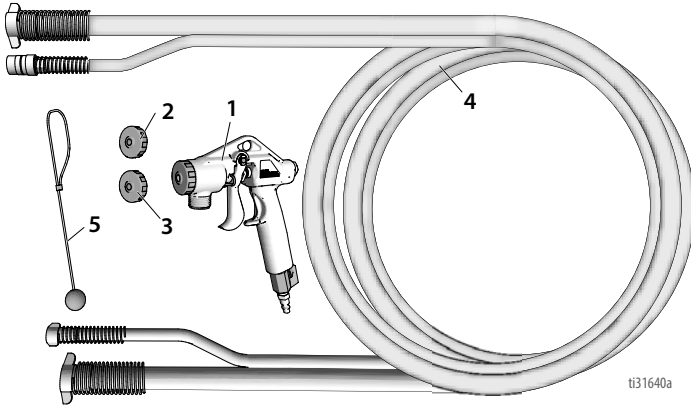

Ref. Part	Description	Qty.
1	288629 GUN, spray, texture	1
2	15B171 NOZZLE, black, 12mm, #3	1
3	15D525 NOZZLE, beige, 4mm	1
4	17J454 HOSE, texture, blue	1
5	15C090 GAUGE, thickness, fluid	1
7	115099 WASHER, garden hose	2

RTX1400si 230V, RTX2000pi and RTX2500pi

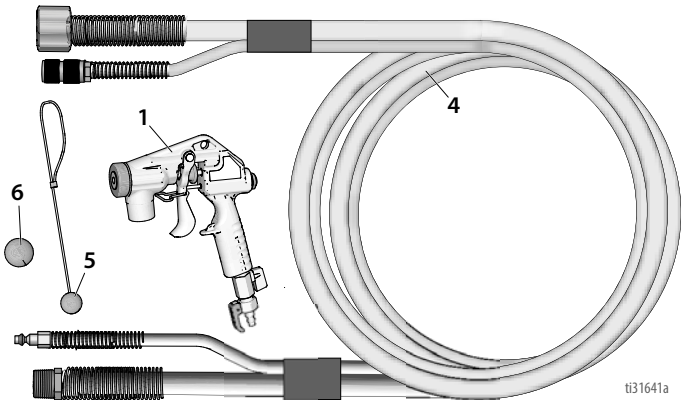

Ref. Part	Description	Qty.
1	24S134 GUN, spray, texture	1
4	17J420 HOSE, texture, 2line	1
5	15C090 GAUGE, thickness, fluid	1
6	113397 BALL, sponge, 30mm	2
7	115099 WASHER, garden hose	1
8	24Z003 ADAPTER, swivel	1

Wiring Diagram

Wiring Diagram

RTX1400si - 120V / RTX1400si - 230V

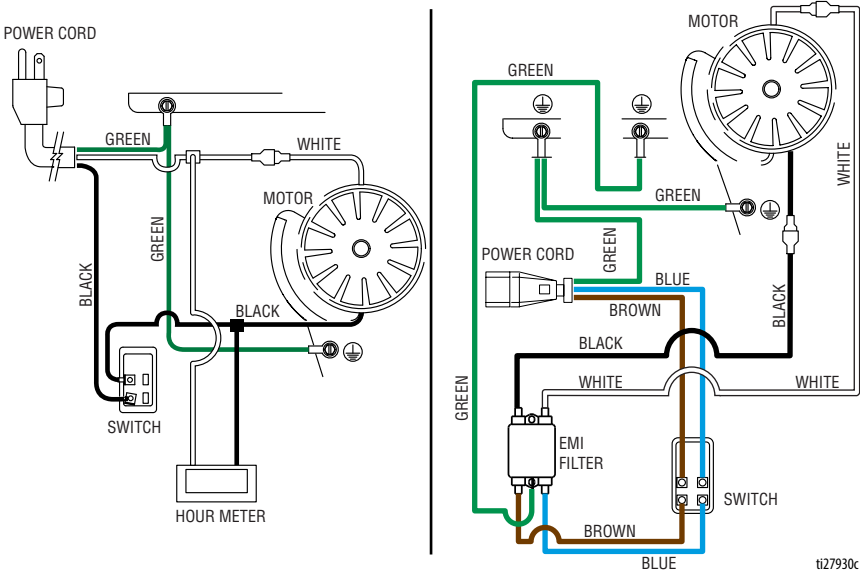

ti27930c

Hour meter on 17P189 models only.

RTX2000pi and RTX2500pi

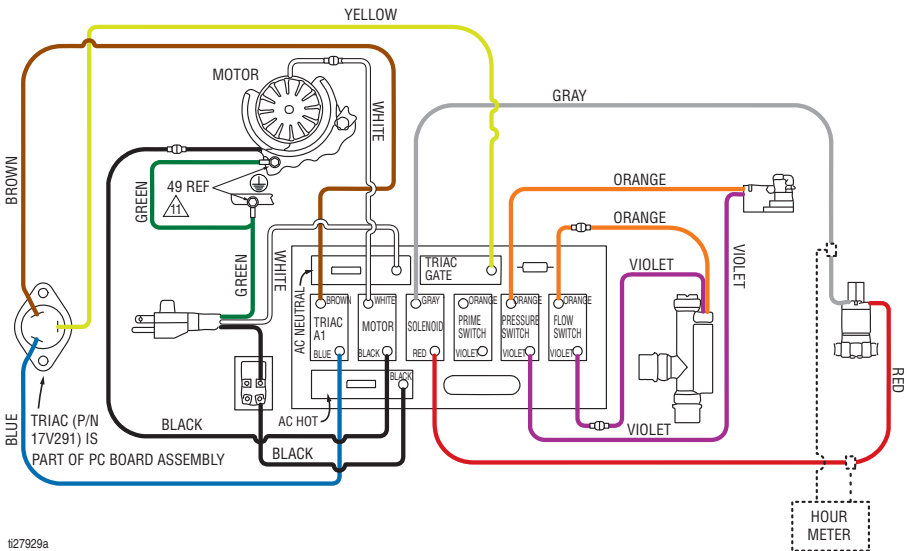

ti27929a

Hour meter on 17H574, 17K301, 17U220 & 17U221 models only.

Wiring Diagram

RTX2500pi - 230V

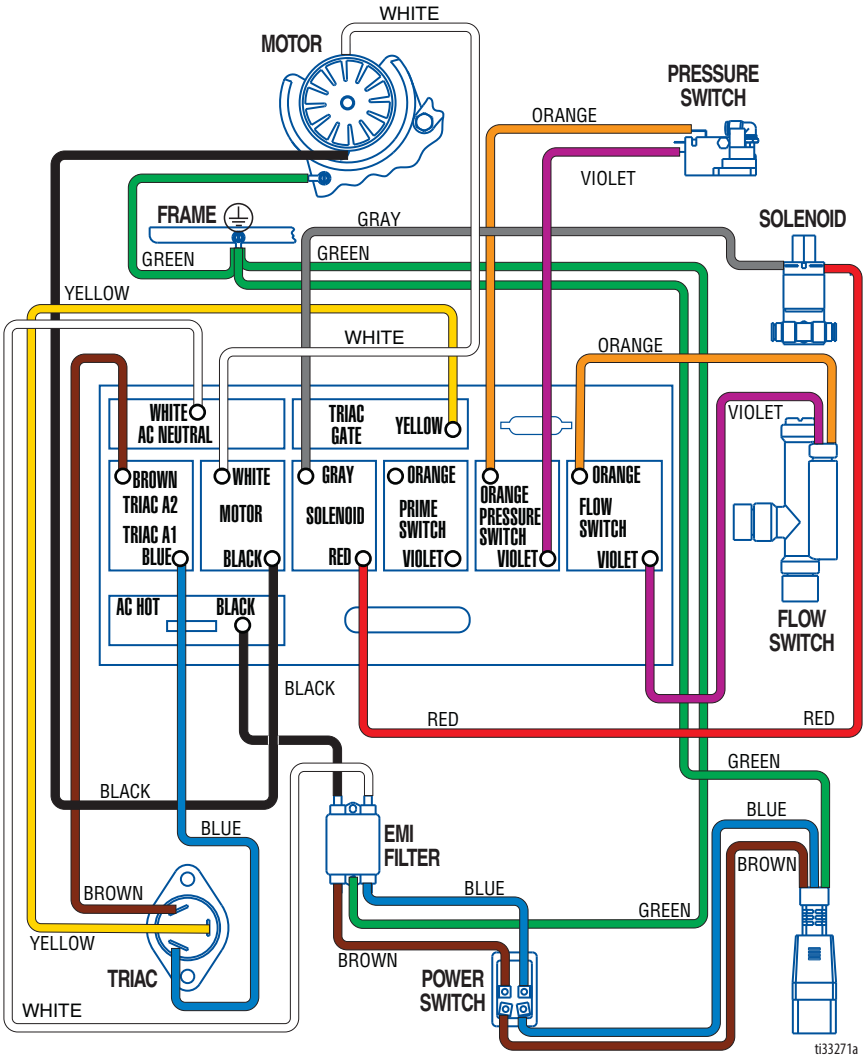

Technical Specifications

Technical Specifications

	US	Metric
Sprayer		
Material Hopper Capacity		
RTX1400si	10 gal	38 l
RTX2000pi	13 gal	49 l
RTX2500pi	15 gal	57 l
Maximum Delivery with Texture		
RTX1400si	1.4 gpm	5.3 lpm
RTX2000pi	2.0 gpm	7.6 lpm
RTX2500pi	2.5 gpm	9.5 lpm
Maximum Fluid Working Pressure		
RTX 1400si / 2000pi	70 psi	4.8 bar, 0.48 MPa
RTX 2500pi	100 psi	6.9 bar, 0.69 MPa
Maximum Air Working Pressure		
Compressor Air Displacement	6.1 cfm @ 20psi	17.3 l/m @ 1.4 bar, 0.14 Mpa
Compressor Specifications		
Universal motor thermally protected, oil-less		
Electric Motor		
Universal AC 15 Amp 1.5 Hp		
Electrical Motor - 230V		
Universal AC 10 Amp 1.5 Hp		
Power Cord		
14 AWG, 3-wire, 25 ft		
Power Cord - 230V		
1.0mm ² , 3-wire, 7.6m		
Generator Minimum		
3500 W		
Power Requirements		
110–120V, 15 A, 1Ø		
Power Requirements - 230V		
220–240V, 50/60 Hz, 10 A, 1Ø		
Dimensions		
Height		
RTX1400si	40.9 in.	104 cm
RTX2000pi / RTX2500pi	41.6 in.	106 cm
Length		
RTX1400si	23.6 in.	60 cm
RTX2000pi / RTX2500pi	24.25 in.	62 cm
Width		
RTX1400si	19.38 in.	49 cm
RTX2000pi / RTX2500pi	22.2 in.	56 cm
Weight (includes hose and gun)		
RTX1400si	74.3 lb.	33.7 kg
RTX2000pi / RTX2500pi	86 lb.	39 kg
Weight (gun)		
RTX1400si - 120V	1.4 lb.	0.6 kg

Technical Specifications

	US	Metric
RTX1400si 230V / RTX2000pi / RTX2500pi	2.3 lb.	1.0 kg
Noise** (dBa) @ max air pressure)		
Sound pressure	88.4 dBa	
Sound power	102.8 dBa	
Storage temperature range ♦❖	-35° to 160°F	-1.6° to 71°C
Operating temperature range ✓	40° to 115°F	4° to 46°C
Materials of Construction		
Wetted materials on all models	brass, aluminum, plastic, stainless steel, plated carbon steel, elastomer	
Notes		
* Startup pressures and displacement per cycle may vary based on suction condition, discharge head, air pressure, and fluid type.		
** Sound pressure measured 3 feet (1 meter) from equipment while spraying. Sound power measured per ISO-9614.		

- ◆ **Pump damage will occur if water-based fluid freezes in pump.**
- ❖ Damage to plastic parts may result if impact occurs in low temperature conditions.
- ✓ Temperature affects material viscosity, which can affect sprayer performance.

Graco Standard Warranty

Graco warrants all equipment referenced in this document which is manufactured by Graco and bearing its name to be free from defects in material and workmanship on the date of sale to the original purchaser for use. With the exception of any special, extended, or limited warranty published by Graco, Graco will, for a period of twelve months from the date of sale, repair or replace any part of the equipment determined by Graco to be defective. This warranty applies only when the equipment is installed, operated and maintained in accordance with Graco's written recommendations.

This warranty does not cover, and Graco shall not be liable for general wear and tear, or any malfunction, damage or wear caused by faulty installation, misapplication, abrasion, corrosion, inadequate or improper maintenance, negligence, accident, tampering, or substitution of non-Graco component parts. Nor shall Graco be liable for malfunction, damage or wear caused by the incompatibility of Graco equipment with structures, accessories, equipment or materials not supplied by Graco, or the improper design, manufacture, installation, operation or maintenance of structures, accessories, equipment or materials not supplied by Graco.

This warranty is conditioned upon the prepaid return of the equipment claimed to be defective to an authorized Graco distributor for verification of the claimed defect. If the claimed defect is verified, Graco will repair or replace free of charge any defective parts. The equipment will be returned to the original purchaser transportation prepaid. If inspection of the equipment does not disclose any defect in material or workmanship, repairs will be made at a reasonable charge, which charges may include the costs of parts, labor, and transportation.

THIS WARRANTY IS EXCLUSIVE, AND IS IN LIEU OF ANY OTHER WARRANTIES, EXPRESS OR IMPLIED, INCLUDING BUT NOT LIMITED TO WARRANTY OF MERCHANTABILITY OR WARRANTY OF FITNESS FOR A PARTICULAR PURPOSE.

Graco's sole obligation and buyer's sole remedy for any breach of warranty shall be as set forth above. The buyer agrees that no other remedy (including, but not limited to, incidental or consequential damages for lost profits, lost sales, injury to person or property, or any other incidental or consequential loss) shall be available. Any action for breach of warranty must be brought within two (2) years of the date of sale.

GRACO MAKES NO WARRANTY, AND DISCLAIMS ALL IMPLIED WARRANTIES OF MERCHANTABILITY AND FITNESS FOR A PARTICULAR PURPOSE, IN CONNECTION WITH ACCESSORIES, EQUIPMENT, MATERIALS OR COMPONENTS SOLD BUT NOT MANUFACTURED BY GRACO. These items sold, but not manufactured by Graco (such as electric motors, switches, hose, etc.), are subject to the warranty, if any, of their manufacturer. Graco will provide purchaser with reasonable assistance in making any claim for breach of these warranties.

In no event will Graco be liable for indirect, incidental, special or consequential damages resulting from Graco supplying equipment hereunder, or the furnishing, performance, or use of any products or other goods sold hereto, whether due to a breach of contract, breach of warranty, the negligence of Graco, or otherwise.

FOR GRACO CANADA CUSTOMERS

The Parties acknowledge that they have required that the present document, as well as all documents, notices and legal proceedings entered into, given or instituted pursuant hereto or relating directly or indirectly hereto, be drawn up in English. Les Parties reconnaissent avoir convenu que la rédaction du présent document sera en Anglais, ainsi que tous documents, avis et procédures judiciaires exécutés, donnés ou intentés, à la suite de ou en rapport, directement ou indirectement, avec les procédures concernées.

Graco Information

For the latest information about Graco products, visit www.graco.com.

For patent information, see www.graco.com/patents.

TO PLACE AN ORDER, contact your Graco distributor or call 1-800-690-2894 to identify the nearest distributor.

All written and visual data contained in this document reflects the latest product information available at the time of publication.

Graco reserves the right to make changes at any time without notice.

Original instructions. This manual contains English. MM 3A3258

Graco Headquarters: Minneapolis
International Offices: Belgium, China, Japan, Korea

GRACO INC. AND SUBSIDIARIES • P.O. BOX 1441 • MINNEAPOLIS MN 55440-1441 • USA

Copyright 2015, Graco Inc. All Graco manufacturing locations are registered to ISO 9001.

www.graco.com

Revision H, September 2018