

SoloTech™ Peristaltic Pumps

3A3367K
EN

Electric-powered hose pump for use in fluid transfer and metering applications. For professional use only. Not approved for use in explosive atmospheres or hazardous locations unless otherwise stated in the model approvals section.



Important Safety Instructions

Read all warnings and instructions in this manual and in your Installation and Operation Manual before using this equipment. Save all instructions.

*125 psi (0.9 MPa, 9 bar) Maximum Fluid Working Pressure
See page 6 for model information.*

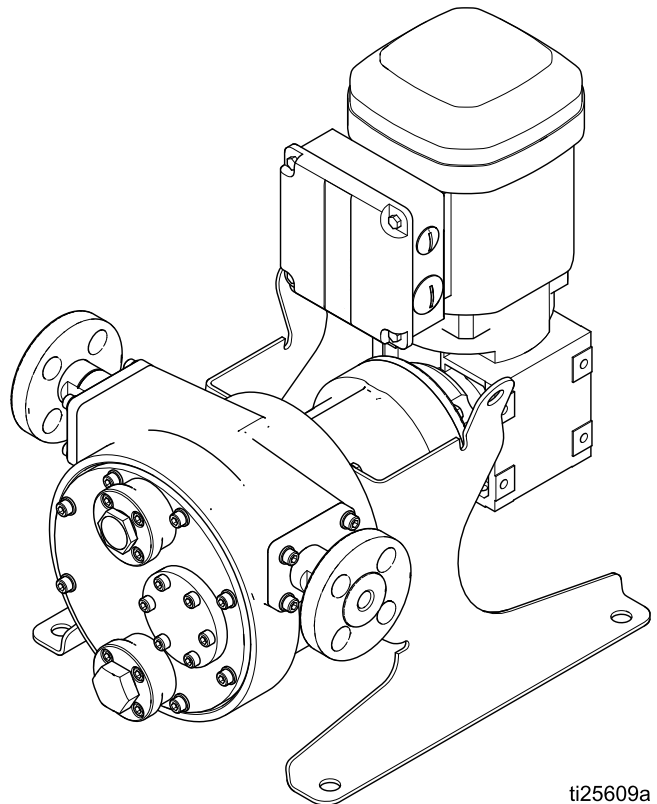

Contents







Related Manuals	2	Remove the Front Cover	10
Warnings	3	Replace the Hose	11
Configuration Number Matrix	6	Replace the Roller	13
Troubleshooting.....	8	Complete Pump Repair	14
Repair.....	10	Parts.....	19
Pressure Relief Procedure.....	10	Kits and Accessories.....	28
Before You Start	10	Technical Data	29
Drain the Lubricant.....	10		

Related Manuals







Manual Number	Title
334859	SoloTech Peristaltic Pumps, Installation and Operation









Warnings

The following warnings are for the setup, use, grounding, maintenance and repair of this equipment. The exclamation point symbol alerts you to a general warning and the hazard symbol refers to procedure-specific risks. When these symbols appear in the body of this manual or on warning labels, refer back to these Warnings. Product-specific hazard symbols and warnings not covered in this section may appear throughout the body of this manual where applicable.

 <h1 style="margin: 0;">WARNING</h1>	
   	<p>FIRE AND EXPLOSION HAZARD</p> <p>Flammable fumes, such as solvent and paint fumes, in work area can ignite or explode. Paint or solvent flowing through the equipment can cause static sparking. To help prevent fire and explosion:</p> <ul style="list-style-type: none"> • Use equipment only in well ventilated area. • Eliminate all ignition sources; such as pilot lights, cigarettes, portable electric lamps, and plastic drop cloths (potential static sparking). • Ground all equipment in the work area. See Grounding instructions. • Keep work area free of debris, including solvent, rags and gasoline. • Do not plug or unplug power cords, or turn power or light switches on or off when flammable fumes are present. • Use only grounded hoses. • Stop operation immediately if static sparking occurs or you feel a shock. Do not use equipment until you identify and correct the problem. • Keep a working fire extinguisher in the work area.
 	<p>ELECTRIC SHOCK HAZARD</p> <p>This equipment must be grounded. Improper grounding, setup, or usage of the system can cause electric shock.</p> <ul style="list-style-type: none"> • Turn off and remove power at main switch before disconnecting any cables and before servicing or installing equipment. • Connect only to grounded power source. • All electrical wiring must be done by a qualified electrician and comply with all local codes and regulations. • Wait five minutes for capacitor discharge before opening equipment. • Always use the recommended amount of genuine Graco hose lubricant to minimize build-up of static electricity.

WARNING

  	<p>PRESSURIZED EQUIPMENT HAZARD Fluid from the equipment, leaks, or ruptured components can splash in the eyes or on skin and cause serious injury.</p> <ul style="list-style-type: none"> • Follow the Pressure Relief Procedure when you stop spraying/dispensing and before cleaning, checking, or servicing equipment. • Tighten all fluid connections before operating the equipment. • Check hoses, tubes, and couplings daily. Replace worn or damaged parts immediately.
 	<p>EQUIPMENT MISUSE HAZARD Misuse can cause death or serious injury.</p> <ul style="list-style-type: none"> • Do not operate the unit when fatigued or under the influence of drugs or alcohol. • Do not exceed the maximum working pressure or temperature rating of the lowest rated system component. See Technical Data in all equipment manuals. • Use fluids and solvents that are compatible with equipment wetted parts. See Technical Data in all equipment manuals. Read fluid and solvent manufacturer's warnings. For complete information about your material, request Safety Data Sheet (SDS) from distributor or retailer. • Turn off all equipment and follow the Pressure Relief Procedure when equipment is not in use. • Check equipment daily. Repair or replace worn or damaged parts immediately with genuine manufacturer's replacement parts only. • Do not alter or modify equipment. Alterations or modifications may void agency approvals and create safety hazards. • Make sure all equipment is rated and approved for the environment in which you are using it. • Use equipment only for its intended purpose. Call your distributor for information. • Route hoses and cables away from traffic areas, sharp edges, moving parts, and hot surfaces. • Do not kink or over bend hoses or use hoses to pull equipment. • Keep children and animals away from work area. • Comply with all applicable safety regulations.
 	<p>THERMAL EXPANSION HAZARD Fluids subjected to heat in confined spaces, including hoses, can create a rapid rise in pressure due to the thermal expansion. Over-pressurization can result in equipment rupture and serious injury.</p> <ul style="list-style-type: none"> • Open a valve to relieve the fluid expansion during heating. • Replace hoses proactively at regular intervals based on your operating conditions.

 <h1 style="margin: 0;">WARNING</h1>	
 	<p>MOVING PARTS HAZARD Moving parts can pinch, cut or amputate fingers and other body parts.</p> <ul style="list-style-type: none"> • Keep clear of moving parts. • Do not operate equipment with protective guards or covers removed. • Pressurized equipment can start without warning. Before checking, moving, or servicing equipment, follow the Pressure Relief Procedure and disconnect all power sources.
 	<p>ENTANGLEMENT HAZARD Rotating parts can cause serious injury.</p> <ul style="list-style-type: none"> • Keep clear of moving parts. • Do not operate equipment with protective guards or covers removed. • Do not wear loose clothing, jewelry or long hair while operating equipment. • Equipment can start without warning. Before checking, moving or servicing equipment, follow the Pressure Relief Procedure and disconnect all power sources.
 	<p>TOXIC FLUID OR FUMES HAZARD Toxic fluids or fumes can cause serious injury or death if splashed in the eyes or on skin, inhaled, or swallowed.</p> <ul style="list-style-type: none"> • Read the Safety Data Sheet (SDS) to know the specific hazards of the fluids you are using. • Store hazardous fluid in approved containers, and dispose of it according to applicable guidelines.
	<p>BURN HAZARD Equipment surfaces and fluid that is heated can become very hot during operation. To avoid severe burns:</p> <ul style="list-style-type: none"> • Do not touch hot fluid or equipment.
	<p>PERSONAL PROTECTIVE EQUIPMENT Wear appropriate protective equipment when in the work area to help prevent serious injury, including eye injury, hearing loss, inhalation of toxic fumes, and burns. Protective equipment includes but is not limited to:</p> <ul style="list-style-type: none"> • Protective eyewear, and hearing protection. • Respirators, protective clothing, and gloves as recommended by the fluid and solvent manufacturer.

Configuration Number Matrix

Check the identification plate (ID) for the Configuration Number of your pump. Use the following matrix to define the components of your pump.

Some combinations are not possible. Check with your local supplier.



Sample Configuration Number: ST23 MAC NR SS A1 A1 0

ST	23	MAC	NR	SS	A1	A1	0
Pump Model	Hose Size	Motor	Hose Material	Barb Material	Roller	Housing	Options

Model	Hose Size		Motor/Gear Reducer	
ST	6	6 mm	HAC†	AC motor with high-speed gear reducer
	10	10 mm	MAC†	AC motor with medium-speed gear reducer
	23	23 mm	LAC†	AC motor with low-speed gear reducer
	25	25 mm	MPM†	Brushless DC (BLDC) motor with gear reducer
	26	26 mm	HC† ♦	High-speed gear reducer, no motor, IEC
	30	30 mm	HN† ♦	High-speed gear reducer, no motor, NEMA
	32	32 mm	MC† ♦	Medium-speed gear reducer, no motor, IEC
			MN† ♦	Medium-speed gear reducer, no motor, NEMA
			LC† ♦	Low-speed gear reducer, no motor, IEC
			LN† ♦	Low-speed gear reducer, no motor, NEMA
			0	No motor or gear reducer

Hose Material/Color	Barb Material	Roller		Housing		Options			
BN	Nitrile (NBR), Yellow	HS	Hastelloy	A1	Aluminum	A1	Aluminum	0	None
CS	Chlorosulfonated Polyethylene (CSM), Orange	PV	PVDF						
EP	Ethylene propylene diene monomer (EPDM), Blue	SS*	Stainless Steel						
FG†■*	Food Grade Nitrile (White)								
NR	Natural Rubber, Black								

* Food Grade pumps ship with stainless steel tri-clamp hose barbs.

Approvals	
◆ These models are certified:	 II 2 G Ex h IIB T4 Gb
† These models are certified:	
‡ These models comply with:	 EC 1935/2004
■ Food Grade fluid contact parts: These materials are FDA-compliant and meet the United States Code of Federal Regulations (CFR) Title 21.	

Troubleshooting

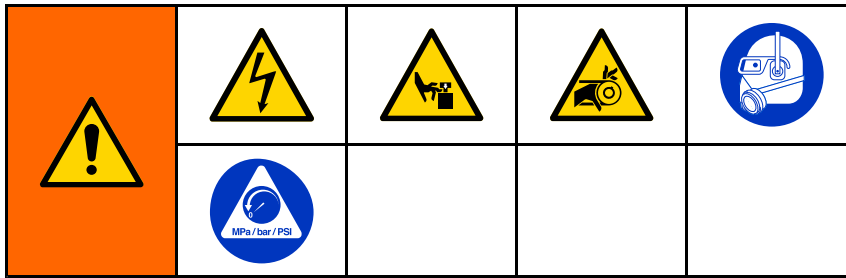

NOTE:

- Follow the [Pressure Relief Procedure, page 10](#).
- Check all possible remedies before disassembling the pump.

See the Operation Manual (334859) for troubleshooting or error information on the Graco Motor Control.

Problem	Cause	Solution
Hammering in piping.	Inlet or outlet pipe diameter is too small.	Increase the pipe size or add pulsation dampeners.
	Pump speed is too high.	Reduce the speed of the pump.
	Inlet or outlet connections are not properly anchored.	Secure the piping.
	Inlet or outlet pressures are too high.	Add pulsation dampeners.
High pump temperature.	Lubricant level is low.	Add hose lubricant to the proper level.
	Improper lubricant is being used.	Use only genuine Graco glycerin hose lubricant for low temperature operation.
	Pumped fluid temperature is too high.	Consult your Graco distributor for maximum temperature limits of your pump and hose material.
	Pump speed is too high or the pump is undersized.	Reduce the pump speed or switch to a larger pump.
High outlet pressure.	Outlet line is blocked.	Clear any obstructions in the outlet line.
	Pipe diameter is narrowed due to settled solids.	Flush/remove as required.
	Viscosity or specific gravity of pumped fluid is too high.	Consult your Graco distributor for suitable operating conditions for your pump.

Problem	Cause	Solution
Low inlet pressure.	The hose has failed.	Replace with a new hose and lubricant.
	Inlet line is blocked.	Clear any obstructions in the inlet line.
	Inlet line is too long or too small.	Try to locate the pump as near to the fluid source as possible. Oversize the inlet piping when possible.
	Viscosity or specific gravity of pumped fluid is too high.	Consult your Graco distributor for suitable operating conditions for your pump.
Low flow.	The hose has failed.	Replace with a new hose and lubricant.
	The back pressure is too high for the combination of fluid viscosity and cycle rate.	Reduce back pressure and/or increase your cycle rate.
Poor hose life.	Hose is incompatible with the fluid being pumped.	Consult your Graco distributor to see if you have the correct hose for your application.
	Hose has failed due to normal wear.	Replace.
	Excessive pulsations have weakened the hose.	If your pump is equipped with a pulsation dampener, adjust its pressure. If you do not have a dampener, consult your Graco distributor.
	Outlet pressure is too high.	Check items listed in "High outlet pressure." Running the pump against a closed valve, even for a short amount of time, may damage the hose.
	Solids have settled in the hose.	Flush the pump and hose prior to turning the pump off.
Hose lubricant is leaking from the front cover.	The cover bolts are not tight enough.	Refer to torque specifications in Install the Front Cover, page 18 .
	The cover gasket is worn or damaged.	Replace.
Hose lubricant is leaking from the hose barb area.	Gaskets are missing or worn.	Replace.
Hose failed because it wrapped around the roller.	Pump was operated against a closed outlet valve or blocked line.	Replace hose. Check pressure relief system. Check that valves are open. Clear any blockages.

Repair

Pressure Relief Procedure



Follow the Pressure Relief Procedure whenever you see this symbol.

<p>This equipment stays pressurized until pressure is relieved manually. To help prevent serious injury from pressurized fluid, such as splashing in the eyes or on skin, follow the Pressure Relief Procedure when you stop pumping and before you clean, check, or service the equipment.</p>				

1. Remove power from the system.
2. Open the dispensing valve, if used.
3. Open the fluid drain valve to relieve fluid pressure. Have a container ready to catch the drainage.

Before You Start

--	--	--	--	--

1. Flush the pump.
2. Follow the [Pressure Relief Procedure, page 10](#).
3. Disconnect power to the pump.
4. Make sure the pump is electrically isolated. Unexpected operation of the pump can cause serious injury. Remove the fan cover only after the motor has been locked out.

Drain the Lubricant

1. Hold a pail under the drain plug (29) and unscrew the plug to drain the lubricant. Dispose of the lubricant properly. Take care, as the lubricant may be contaminated by the pumped fluid.
2. Remove the vent plug (30) and flush the pump housing with a compatible solvent.

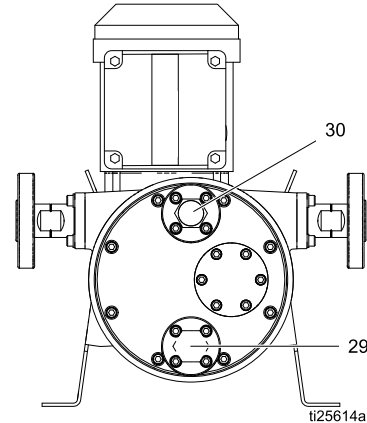

Figure 1 Pump Drain (29) and Vent (30)

Remove the Front Cover

1. Drain the lubricant per the instructions in the previous section.
2. See Figure 2, page 10. Use a wrench to remove the bolts (45) and washers (52, 53, if present) that hold the front cover (16), removing the top screw and washer (if present) last. Take the cover off the pump. If the cover is stuck, gently break the gasket seal with a flat-headed screwdriver between the cover and the housing.

Pump Model	Wrench size
ST6, ST10, ST23, and ST25FG	10 mm
ST26	13 mm
ST30 and ST32	17 mm

3. Remove the front cover gasket (15).

Replace the Hose

Remove the Hose

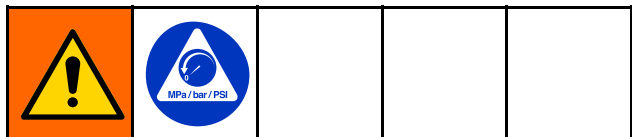

1. Follow the [Pressure Relief Procedure, page 10](#).
2. Follow the steps under [Drain the Lubricant, page 10](#), and [Remove the Front Cover, page 10](#).
3. The roller must be moved to remove the hose. Follow the directions for your pump to move the roller between the 4- and 8-o'clock positions while pulling on the hose at the bottom until the hose is free from the roller.
 - a. **AC Models:** Loosen the screws and remove the motor fan cover (FC). Turn the fan by hand to move the roller.

NOTE: Low RPM pumps and high ratio gearboxes may require many turns of the motor fan to move the roller.
 - b. **BLDC Models:**
 - i. Insert the shaft socket tool (59) into the back of the gearbox.
 - ii. Use a socket wrench to move the roller.
 - iii. Remove the socket from the gearbox.

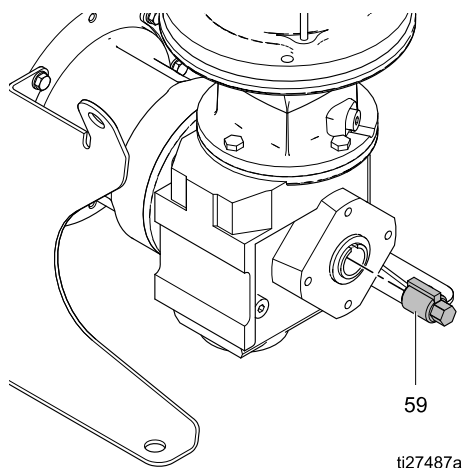

4. Use a wrench to remove the four nuts (35) from the hose barb assembly on one port. Pull the hose so it extends about 2–3 in. (51–76 mm) out of the pump. Remove the nuts (35) from the barb assembly on the other port, and pull the hose so it extends about 2–3 in. (51–76 mm) out of the pump.

Pump Model	Wrench size
ST6, ST10, ST23, and ST25FG	10 mm
ST26, ST30, and ST32	13 mm

5. Use a 7mm wrench or a flat-headed screwdriver to loosen the hose clamps (24).
6. Pull the barb assembly off of the hose on one side, then remove the gasket (25) and clamp (24).
7. Grasp the hose (14) from the inside of the pump housing and pull it into the pump housing and out of the front. Drain the hose contents into a bucket.
8. Remove the second barb assembly, the gasket (25) and the clamp (24).
9. Pull the other end of the hose into the pump housing and out of the front.
10. Remove and safely discard the used hose per your facility's waste disposal policy. Wipe clean the inside of the pump housing.

NOTE: To continue with disassembly, see [Remove the Roller, page 13](#). If you are replacing the hose, continue with the next section.

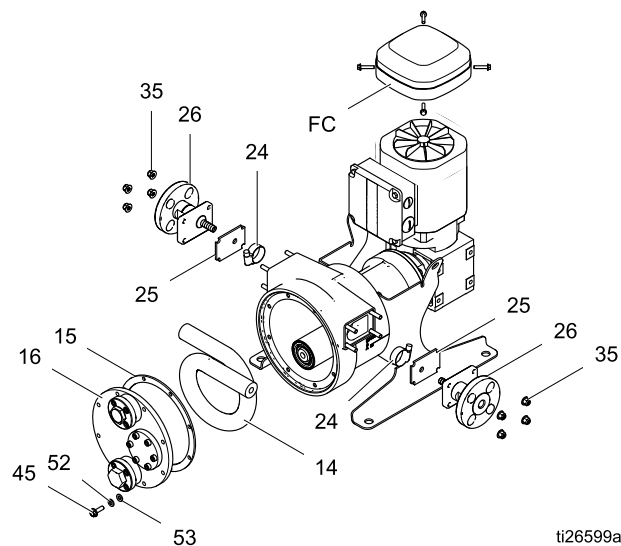

Figure 2 Remove or Install the Hose

Install the Hose

1. Install a gasket (25) onto each hose barb (28) so that it mates with the plate (26).
2. Insert one end of the hose through the left housing port and extend the hose 2–3 in. (51–76 mm) beyond the pump housing (1).
3. Orient the hose clamp so the clamp housing aligns with the recessed cavity in the pump housing. Slide the hose clamp over the hose. Slide on the barb assembly.
4. Tighten the clamp. Torque to 25 ft-lb (33.9 N•m) plus one full turn. Or, tighten the clamp so that the clamp is flush with the outer hose diameter.
5. Push the hose and clamp into the pump housing.
6. Use nuts (35) to attach the hose barb assembly to the pump. Torque to the value specified in the table.

Pump Model	Torque
ST6 , ST10 , ST23 , and ST25FG	8 ft-lb (10.8 N•m)
ST26 , ST30 , and ST32	18 ft-lb (24.4 N•m)

7. Loop the hose 360 degrees and insert the second end through the opposite side port.

8. Repeat steps 3–6.
9. The roller must be moved to install the hose. Follow the directions for your pump to move the roller. Start at the 4 o'clock position and move the roller to the 8 o'clock position while pushing the hose in at the bottom. Be sure the hose is past the plane of the cover gasket.
 - a. **AC Models:** Loosen the screws and remove the motor fan cover. Turn the fan by hand to move the roller.
NOTE: Low RPM pumps and high ratio gearboxes may require many turns of the motor fan to move the roller.
 - b. **BLDC Models:**
 - i. Insert the shaft socket tool (29) into the back of the gearbox.
 - ii. Use a socket wrench to move the roller.
10. **AC Models:** Reinstall the motor fan cover. **BLDC Models:** Remove the socket from the gearbox.
11. Follow the steps under [Install the Front Cover, page 18](#).

Replace the Roller

The bearings in the roller are sealed and non-serviceable. If the bearings fail, replace the roller assembly.

Remove the Roller

1. Follow the steps in [Remove the Hose, page 11](#).
2. Use a flat-headed screw driver on the inside diameter to pry out the rotary shaft seals (13a and 13b). Discard the seals.
3. Use external snap ring pliers to remove the roller retaining ring (12) from the front of the eccentric shaft (9).
4. Pull the roller (11) off the shaft (9).
5. Inspect the inside and outside diameter of the roller (11), and replace it if worn or damaged.

NOTE: To continue with disassembly, see [Remove the Eccentric Shaft, page 14](#). If you are replacing the roller, continue with the next section.

Install the Roller

1. Lubricate the eccentric shaft (9) with hose lubricant. Slide the roller (11) onto the shaft.
- NOTE:** The roller has an orientation groove on one end that must face out of the pump housing.
2. Install a roller retaining ring (12) and the outer shaft seals (13a, 13b). The lips of the seals must face **out** from the center of the roller. Install the seals so they are flush with the roller edge. If you are replacing the roller, seal 13b is press fit into the roller at the factory.
 3. Turn the roller (11) by hand to verify that it turns freely on the shaft (9).
 4. Follow the steps under [Install the Front Cover, page 18](#).

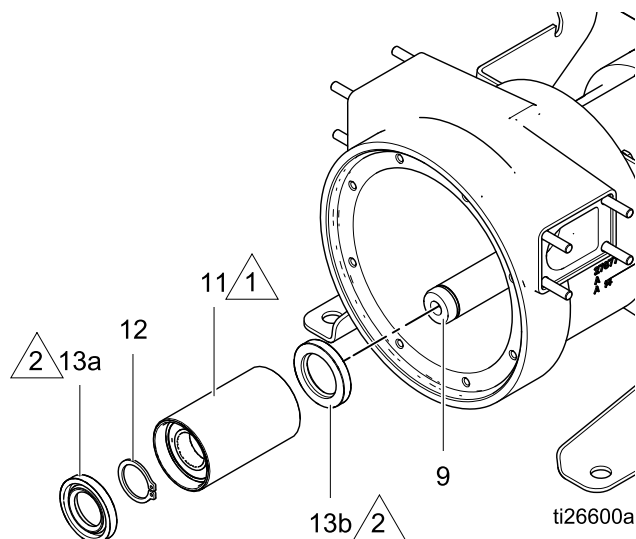

Figure 3 Remove or Install the Roller

KEY



The orientation groove on one end of the roller must face out of the pump housing.



Lips must face **out** from the center of the roller.

Complete Pump Repair

Disassembly

Complete pump disassembly is necessary only to replace the main shaft assembly, for example in the case of a failed bearing.

Remove the Eccentric Shaft

1. Follow the steps in [Remove the Hose, page 11](#).
2. Follow the steps in [Remove the Roller, page 13](#).
3. Use external snap ring pliers to remove the eccentric shaft retaining ring (10) from the motor output shaft (6).
4. Remove the eccentric shaft (9) from the motor output shaft (6). **Be sure to retain the eccentric shaft key (56).**

NOTE: You may need to use a puller to disengage the eccentric shaft from the motor output shaft.

Pump Model	Bolt Size
ST6 and ST10	6 mm
ST23 , ST25FG , ST26 , ST30 , and ST32	8 mm

Remove the Motor Output Shaft

See Figure 4 on page 15.

1. Remove the four screws (31) and washers (21) that hold the gearbox and motor assembly (4) to the pump housing (1).
2. Remove the plastic plugs on the back of the motor to reveal threaded metric holes for a gear puller. Inspect the center opening. If it contains a snap ring, remove it.
3. Use a gear puller to remove the gearbox and motor assembly. **Be sure to retain the motor output shaft key (57).**

NOTE: For motor and gearbox repair information, contact SEW-Eurodrive.

4. Use a flat head screw driver on the inside diameter to remove the front rotary shaft seal (8). Discard the seal.
5. Use a large internal snap ring pliers to remove the retaining ring (7) from the pump housing (1).
6. Gently tap the gearbox end of the shaft (6) with a rubber mallet to drive the shaft out through the front of the pump housing (1).
7. Remove and discard the rear rotary shaft seal (5).

Reassembly

Clean and Inspect All Parts

NOTICE

Use only genuine Graco replacement parts. Non-standard parts will void your warranty and may damage your equipment.

- Discard all used seals, gaskets and worn parts.
- Ensure that all new and existing parts are clean and undamaged.
- Thoroughly clean all parts with a compatible solvent and inspect for damage or wear. Replace all gaskets, washers, worn parts and hardware as necessary.
- Inspect the outer diameter of the pump roller. If the surface has been worn, replace the roller.
- Inspect the bearings on the motor output shaft (6). If the bearings are worn, replace the shaft assembly.
- Inspect the shaft and bearing bore in the pump housing (1). Ensure it is round, without grooves or other signs of wear, and free of dirt, filings, or other debris. A dirty or damaged bearing bore will greatly reduce the life of the bearings.
- Inspect all metal parts for signs of wear or cracks. Replace all worn parts.

NOTICE

The pump housing is aluminum. To help prevent galling, inspect the bolt threads for foreign material and clean or replace if necessary.

Install the Motor Output Shaft

1. Inspect the bearings and make sure that all rotate freely and are seated against the shoulder of the shaft (6).
2. Install the eccentric shaft key (56).
3. Coat the outer races of the shaft bearings and the inner diameter of the housing with lithium-based grease. Make sure there is no dirt or debris on either the bearings or the housing.
4. Insert the shaft (6) into the pump housing (1) from the front. Make sure that the bearings engage the opening flush and straight. If necessary, lightly tap the roller end of the shaft with a rubber mallet until the shaft is firmly seated in the pump housing.

Alternative Method: Prop the housing so the front is facing up. Insert the shaft from the top down.

NOTICE

Do not force the shaft and bearings into the pump housing. This may cause damage to the bearings or the housing.

5. Install the bearing retaining ring (7) in front of the outer bearing.

Install the Seals

1. Clean the surfaces that the seals will contact.
2. Grease the pump with lithium-based grease. Remove the plug (33) from the pump housing and replace with a zerk fitting (1/8–27 npt, not included). Add grease until it passes through the outer bearing of the shaft. This provides a visual reference of the proper amount of grease. Remove the zerk fitting.

3. Press a new seal (5) onto the pump end of the shaft (6) and a new seal (8) into the bore at the front of the pump housing (1). The lips of the seals must face toward the shaft bearings. Do not install the seals past the plane of the housing.

NOTE: If the seals are installed too deep, they may cause excessive friction.

4. Turn the shaft by hand a couple of times to be sure that the shaft rotates smoothly.
5. Reinstall the plug (33).

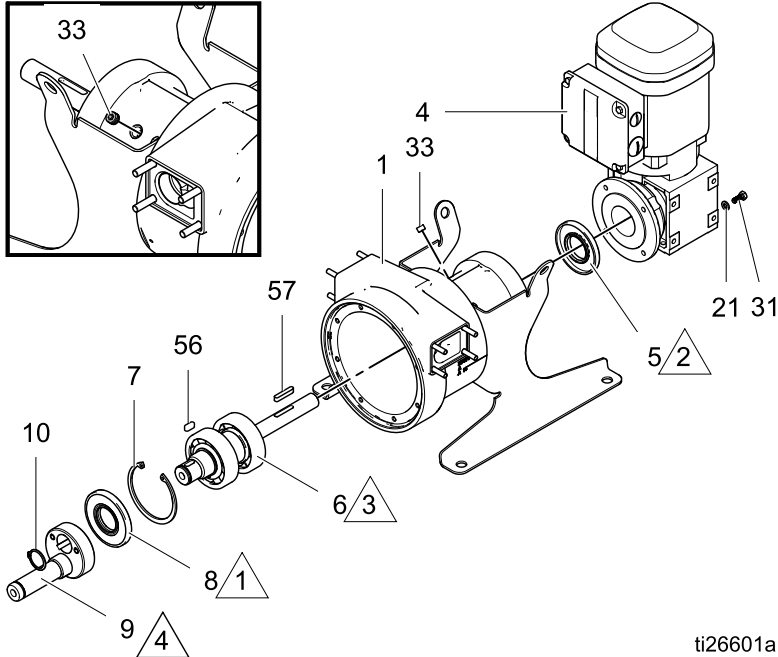

ti26601a

Figure 4 Remove or Install the Motor Output Shaft and Eccentric Shaft

Key



Lips of the front rotary shaft seal (8) must face toward the shaft bearings.



Lips of the rear rotary shaft seal (5) must face into the pump housing.



Lubricate with lithium-based grease.



Lubricate with anti-seize compound

Install the Motor and Gearbox

1. Use an anti-seize compound to lubricate the motor output shaft (6) and the keyway.
2. Install the motor output shaft key (57).
3. Remove the plastic cap on the back of the gearbox, if one is present.
4. Slide the motor and gearbox assembly (4) onto the shaft (6). Secure the assembly to the pump housing (1) with the four screws (31) and washers (21). Torque to the value shown in the table.

Model	Torque
ST6 , ST10 , ST23 , and ST25FG	8 ft-lb (10.8 N•m)
ST26	18 ft-lb (24.4 N•m)
ST30 and ST32	32 ft-lb (43.4 N•m)

Install the Eccentric Shaft

1. Verify that the eccentric shaft key (56) is installed.
2. Use an anti-seize compound to lubricate the eccentric shaft (9). Slide the eccentric shaft over the end of the motor output shaft (6). Use a soft rod and a plastic mallet to tap lightly on the round base until the eccentric shaft is fully seated on the motor output shaft.
3. Secure the eccentric shaft (9) with the retaining ring (10).
4. Follow the steps under [Install the Roller, page 13](#), and [Install the Hose, page 12](#).

Install the Front Cover



1. Clean any debris from the gasket mating surfaces on the front cover (16) and the pump housing (1).

NOTE: The pump housing and front cover must be free of dirt, debris and residue to ensure a leak-free seal.

2. Line up the holes in the gasket (15) with the holes in the cover (16). Place the gasket on the cover.
3. Line up the front cover (16) and gasket (15) with the pump housing (1). **ST6, ST10, ST23, and ST25FG:** Install the flangehead bolts (45) onto the front cover (16). **ST26, ST30, and ST32:** Install the bolts (45), with flat washers (53) and lock washers (52), onto the front cover (16). Torque the bolts evenly and oppositely to the torque shown in the table.

Model	Torque
ST6, ST10, ST23, and ST25FG	8 ft-lb (10.8 N•m)
ST26	18 ft-lb (24.4 N•m)
ST30 and ST32	32 ft-lb (43.4 N•m)

Lubricate the Pump

				
<p>To reduce the risk of fire or explosion that can result from static sparking or chemical incompatibility:</p> <ul style="list-style-type: none"> • Verify that the hose lubricant is compatible with your pumped fluid. Do not use glycerin hose lubricant if pumping strong oxidizer or acids. • Keep the pump properly filled with genuine Graco hose lubricant. 				

NOTICE
<p>The vent and drain port threads are aluminum. To help prevent galling, inspect the bolt threads for foreign material and clean or replace if necessary.</p>

1. Wrap the drain plug (29) threads with PTFE tape and install the plug into the bottom cover port. Be sure that it is tight to prevent leakage of lubricant.
2. Use a funnel with a flexible spout to add hose lubricant through the vent port. The lubricant level must cover the bottom of the roller.

NOTE: If you are using the optional leak sensor, overfilling may cause nuisance tripping of the sensor.

See the following table for the correct amount of lubricant for your pump. Pre-measuring the correct amount will help prevent overfilling.

Pump Model	Amount of Hose Lubricant (approximate)
ST6 ST10	4.5 fl oz (130 ml)
ST23 ST25FG	12 fl oz (350 ml)
ST26	27 fl oz (800 ml)
ST30 ST32	34 fl oz (1000 ml)

3. Wrap the vent plug (30) threads with PTFE tape and screw it into the vent port.

Hose Lubricant (order separately)

Glycerin	Silicone	Volume
24K691	— — —	Quart (0.95 l)
24Y920	— — —	Half Gallon (1.89 l)
24K693	24K686	Gallon (3.79 l)
24M435	24M434	55 Gallons (208 l)

Parts

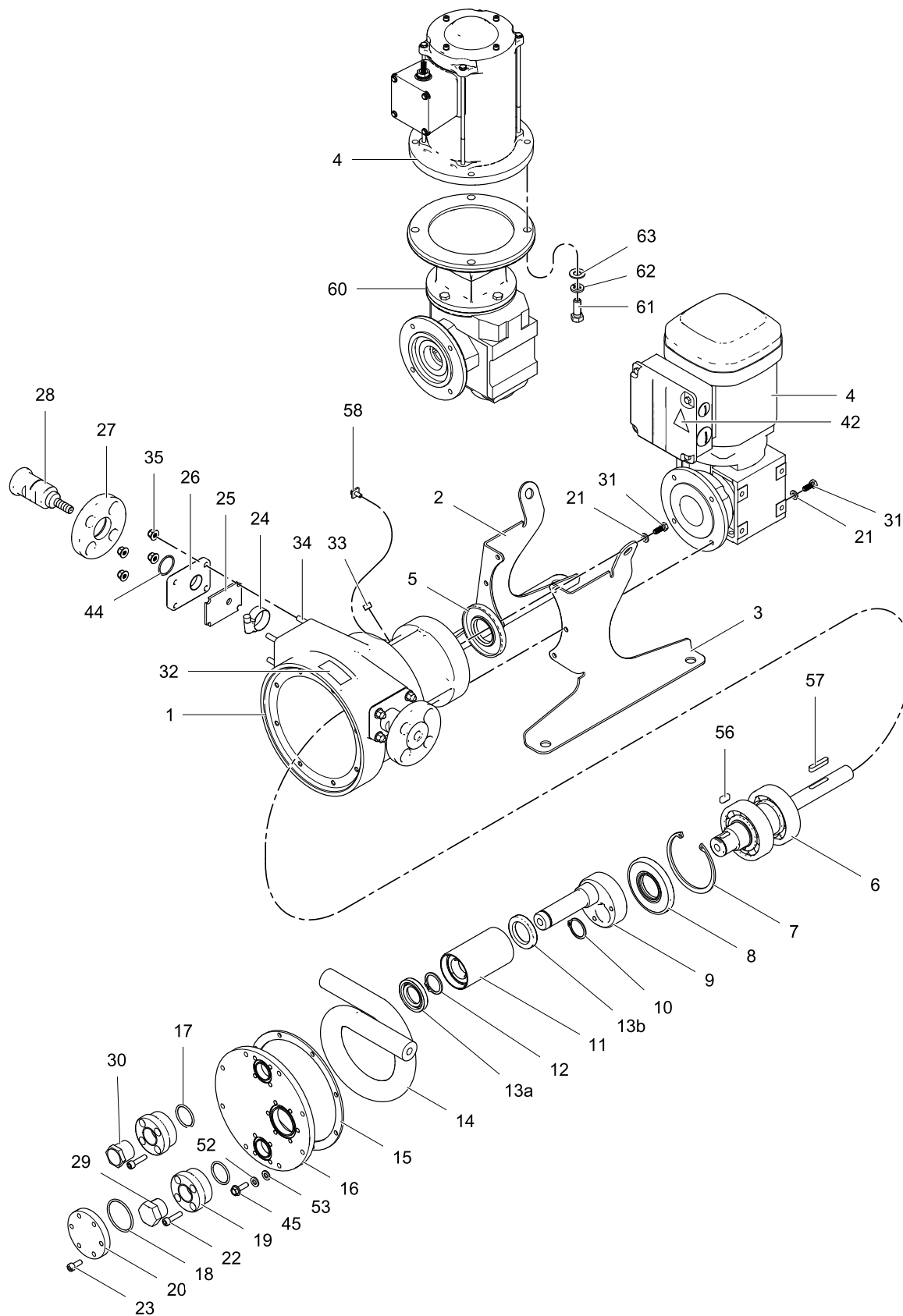

ST6, ST10, and ST10FG Parts

ST6, ST10, and ST10FG Parts			
Ref	Part	Description	Qty
1	— — —	HOUSING, pump	1
2	17C220	FOOT, mounting, left	1
3	17C221	FOOT, mounting, right	1
4	25A365 25A366 25A367 24Z038	MOTOR, AC HAC ; 0.75 hp, 19.50:1 MAC ; 0.50 hp, 48.00:1 LAC ; 0.25 hp, 157.43:1 MPM ; BLDC, 1.0 hp	1
5‡	— — —	SEAL, motor shaft, rear	1
6‡	— — —	MOTOR SHAFT, subassembly	1
7‡	— — —	RING, retaining, internal, 80 mm	1
8‡	— — —	SEAL, motor shaft, front	1
9	24Y837	ECCENTRIC SHAFT (driver assembly), kit; includes ref. 10	1
10	— — —	RING, retaining, external, 27 mm; included with ref. 9	1
11	24Y789	ROLLER ASSEMBLY, kit; includes ref. 12 and 13	1
12	— — —	RING, retaining, external, 25 mm	1
13a, 13b	24Y845	SEALS, eccentric shaft, front and back	1 ea.
14	19C737 19C739 19C740 19C738 24Y797 24Y798 24Y799 24Y800 19D234	HOSE, 6 mm, for ST6 Natural Rubber, black CSM, orange EPDM, blue Nitrile, yellow HOSE, 10 mm, for ST10 Natural Rubber, black CSM, orange EPDM, blue Nitrile, yellow HOSE, 10 mm, Food Grade Nitrile, for ST10FG	1
15*†	— — —	GASKET, front cover	1
16*	24Y829 24Y898 19C942	FRONT COVER, kit for ST6 for ST10 for ST10FG	1
17*	121110	O-RING	2

ST6, ST10, and ST10FG Parts			
Ref	Part	Description	Qty
18*	107249	O-RING	1
19*	17C529	HANDLE, cover	2
20*	17C521	SIGHTGLASS	1
21	117018	WASHER	10
22*	124164	SCREW, M6-1.0 x 25mm, stainless steel	8
23*	124313	SCREW, M6-1 x 16mm, stainless steel	6
24	24Y825	CLAMP, hose, size 12	2
25†	— — —	GASKET, hose plate	2
26	17B693	PLATE, hose barb	2
27■	17B690	FLANGE, hose barb	2
28	19C907 19C918 24Y813 24Y814 24Y815 19D236	BARB, kit, for ST6 ; includes o-ring (ref. 44) Stainless steel PVDF BARB, kit, for ST10 ; includes o-ring (ref. 44) Stainless steel PVDF Hastelloy BARB, kit, for ST10FG ; includes o-ring (ref. 44)	2
29*	16K274	PLUG, hex, 3/4 npt	1
30*	16K281	VENT, breather, muffler; 3/4 npt	1
31	114670	SCREW, cap, hex head, M6-1 x 16mm	10
32▲	16K630	LABEL, warning	1
33	110208	PLUG, pipe, headless	1
34	— — —	STUD, M6, fastener	8
35	17G152	NUT, lock, hex, flange,	8
42▲	15J075	LABEL, warning	1
43	Δ	LUBRICANT	1
44	103255	O-RING; included with ref. 28	2
45*	17G170	SCREW, flange head, M6-1 x 20 mm	8
54	24Y445	GRACO MOTOR CONTROL; used on MPM (BLDC) pumps	1
55	15Y051	CABLE, M12, 8 pin, m/f, 3.0 m (9.8 ft); used on MPM (BLDC) pumps	1

ST6, ST10, and ST10FG Parts			
Ref	Part	Description	Qty
56†	17C575	KEY, eccentric shaft	1
57	25A838	KEY, motor output shaft	1
58	116343	SCREW, ground	1
59	17B594	TOOL, BLDC, shaft socket	1
60	24Z039	GEARBOX, BLDC	1

ST6, ST10, and ST10FG Parts			
Ref	Part	Description	Qty
61	— — —	SCREW, cap, hex hd, 3/8-16 x 1, grade 8.8	4
62	— — —	WASHER, lock, 3/8	4
63	— — —	WASHER, flat, 3/8	4

Notes for ST6, ST10, and ST10FG Parts:

▲ *Replacement Danger and Warning labels, tags, and cards are available at no cost.*

— — — *Not sold separately.*

* *Parts included in Front Cover Kit, Ref. 16*

† *Parts included in Gasket Kit 24Y833.*

‡ *Parts included in Main Shaft Kit 24Y841.*

△ *See [Lubricate the Pump, page 18](#) for ordering information.*

■ *Not used in food grade pump models.*

ST23 and ST25FG Parts

ST23 and ST25FG Parts			
Ref	Part	Description	Qty
1	---	HOUSING	1
2	17C222	FOOT, mounting, left	1
3	17C223	FOOT, mounting, right	1
4		MOTOR, AC	1
	25A368	HAC; 1.0 hp, 19.13:1	
	25A369	MAC; 0.75 hp, 48.00:1	
	25A367	LAC; 0.25 hp, 157.43:1	
	24Z038	MPM; 1.0 hp, BLDC	1
5‡	---	SEAL, rotary shaft, rear	1
6‡	24Y842	MOTOR OUTPUT SHAFT, kit	1
7‡	---	RING, retaining, internal, 90 mm	1
8‡	---	SEAL, rotary shaft, front	1
9	24Y838	ECCENTRIC SHAFT (driver assembly), kit; includes ref. 10	1
10	---	RING, retaining, external, 40 mm, included with ref. 9	1
11	24Y794	ROLLER ASSEMBLY, kit, includes refs. 12 and 13	1
12	---	RING, retaining, external, 35 mm	1
13a, 13b	24Y846	SEALS, rotary shaft, front and back	1 ea.
14		HOSE, 23 mm, for ST23	1
	24Y801	Natural Rubber, black	
	24Y802	CSM, orange	
	24Y803	EPDM, blue	
	24Y804	Nitrile, yellow	
	19C745	HOSE, 25 mm, Food Grade, for ST25FG	1
15*†	---	GASKET, front cover	1
16*		FRONT COVER, kit	1
	24Y830	for ST23	
	19C912	for ST25FG	
17*	121110	O-RING	2
18*	117337	O-RING	1
19*	17C529	HANDLE, cover	2
20*	17F092	SIGHTGLASS	1
21	117018	WASHER	10
22*	124164	SCREW, M6-1.0 x 25mm, stainless steel	8

ST23 and ST25FG Parts			
Ref	Part	Description	Qty
23*	124313	SCREW, M6-1 x 16mm, stainless steel	6
24	24Y826	CLAMP, hose, size 20	2
25†	---	GASKET, hose plate	2
26	17B694	PLATE, hose barb	2
27■	17B691	FLANGE, hose barb	2
28		BARB, kit, for ST23 ; includes o-ring (ref. 44)	2
	24Y816	Stainless steel	
	24Y817	PVDF	
	24Y818	Hastelloy	
	19C910	BARB, kit, for ST25FG ; includes o-ring (ref. 44)	2
29*	16K274	PLUG, hex, 3/4 npt	1
30*	16K281	VENT, breather, muffler, 3/4 npt	1
31	114670	SCREW, cap, hex head, M6-1 x 16mm	10
32▲	16K630	LABEL, warning	1
33	110208	PLUG, pipe, headless	1
34	---	STUD, M6, fastener	8
35	17G152	NUT, lock, hex, flange,	8
42▲	15J075	LABEL, warning	1
43	Δ	LUBRICANT	1
44	107550	O-RING; included with ref. 28	2
45*	17G170	SCREW, flange head, M6-1 x 20 mm	8
54	24Y445	GRACO MOTOR CONTROL; used on MPM (BLDC) pumps	1
55	15Y051	CABLE, M12, 8 pin, m/f, 3.0 m (9.8 ft); used on MPM (BLDC) pumps	1
56‡	17C576	KEY, eccentric shaft	1
57	25A838	KEY, motor output shaft	1
58	116343	SCREW, ground	1
59	17B594	TOOL, BLDC, shaft socket	1
60	24Z039	GEARBOX, BLDC	1
61	---	SCREW, cap, hex hd, 3/8-16 x 1, grade 8.8	4
62	---	WASHER, lock, 3/8	4
63	---	WASHER, flat, 3/8	4

Notes for ST23 and ST25FG Parts:

▲ Replacement Danger and Warning labels, tags, and cards are available at no cost.

— — — Not sold separately.

* Parts included in Front Cover Kit, Ref. 16.

† Parts included in Gasket Kit 24Y834.

‡ Parts included in Main Shaft Kit 24Y842.

△ See [Lubricate the Pump, page 18](#) for ordering information.

■ Not used in food grade pump models.

ST26 and ST26FG Parts

ST26 and ST26FG Parts			
Ref	Part	Description	Qty
1	— — —	HOUSING	1
2	17C224	FOOT, mounting, left	1
3	17C225	FOOT, mounting, right	1
4	25A370	MOTOR, AC HAC; 2.0 hp, 19.27:1	1
	25A371	MAC; 1.0 hp, 47.02:1	
	25A372	LAC; 0.33 hp, 145.00:1	
	24Z037	MPM; 1.5 hp, BLDC	
5‡	— — —	SEAL, rotary shaft, rear	1
6‡	24Y843	MOTOR OUTPUT SHAFT, kit	1
7‡	— — —	RING, retaining, internal, 110 mm	1
8‡	— — —	SEAL, rotary shaft, front	1
9	24Y839	ECCENTRIC SHAFT (driver assembly), kit; includes ref. 10	1
10	— — —	RING, retaining, external, 45 mm; included with ref. 9	1
11	24Y795	ROLLER ASSEMBLY, kit, includes ref. 13	1
12	— — —	RING, retaining, external, 45 mm	1
13a, 13b	24Y847	SEALS, rotary shaft, front and back	1 ea.
14	24Y805	HOSE, 26 mm, for ST26 Natural Rubber, black	1
	24Y806	CSM, orange	
	24Y807	EPDM, blue	
	24Y808	Nitrile, yellow	
	19C714	HOSE, 26 mm, Food Grade, sanitary, for ST26FG	
15*†	— — —	GASKET, front cover	1
16*		FRONT COVER, kit	1
	24Y831	for ST26	
	19C913	for ST26FG	
17*	121110	O-RING	2
18*	C20242	O-RING	1
19*	17C529	HANDLE, cover	2
20*	17C608	SIGHTGLASS	1
21	108788	WASHER	10
22*	124164	SCREW, M6-1.0 x 25mm, stainless steel	8
23*	124313	SCREW, M6-1 x 16mm, stainless steel	6

ST26 and ST26FG Parts			
Ref	Part	Description	Qty
24	24Y827	CLAMP, hose, size 28	2
25†	— — —	GASKET, hose plate	2
26	17B695	PLATE, hose barb	2
27■	17B691	FLANGE, hose barb	2
28	24Y819	BARB, kit, for ST26; includes o-ring (ref. 44) Stainless steel	2
	24Y820	PVDF	
	24Y821	Hastelloy	
	19C910	BARB, kit, Food Grade, sanitary, for ST26FG; includes o-ring (ref. 44)	2
29*	16K274	PLUG, hex, 3/4 npt	1
30*	16K281	VENT, breather, muffler	1
31	107558	SCREW, cap, hex head, M8-1.25 x 25mm	10
32▲	16K630	LABEL, warning	1
33	110208	PLUG, pipe, headless	1
34	— — —	STUD, M8, fastener	8
35	17G188	NUT, lock, hex, flange,	8
42▲	15J075	LABEL, warning	1
43	Δ	LUBRICANT	1
44	107550	O-RING; included with ref. 28	2
45*	112084	SCREW, flange head, M8-1.25 x 25mm	8
52*	107542	WASHER, lock, spring	8
53*	111003	WASHER, flat	8
54	24Y445	GRACO MOTOR CONTROL; used on MPM (BLDC) pumps	1
55	15Y051	CABLE, M12, 8 pin, m/f, 3.0 m (9.8 ft); used on MPM (BLDC) pumps	1
56‡	17C577	KEY, eccentric shaft	1
57	25A839	KEY, motor output shaft	1
58	116343	SCREW, ground	1
59	17B595	TOOL, BLDC, shaft socket	1
60	24Z040	GEARBOX, BLDC	1
61	— — —	SCREW, cap, hex hd, 3/8-16 x 1, grade 8.8	4
62	— — —	WASHER, lock, 3/8	4
63	— — —	WASHER, flat, 3/8	4

Notes for ST26 and ST26FG Parts:

▲ Replacement Danger and Warning labels, tags, and cards are available at no cost.

— — — Not sold separately.

* Parts included in Front Cover Kit, Ref. 16.

† Parts included in Gasket Kit 24Y835.

‡ Parts included in Main Shaft Kit 24Y843.

△ See [Lubricate the Pump, page 18](#) for ordering information.

■ Not used in food grade pump models.

ST30, ST32, and ST32FG Parts

ST30, ST32, and ST32FG Parts			
Ref	Part	Description	Qty
1	— — —	HOUSING	1
2	17C226	FOOT, mounting, left	1
3	17C227	FOOT, mounting, right	1
4		MOTOR, AC	1
	25A374	HAC ; 3.0 hp, 19.70:1	
	25A375	MAC ; 1.5 hp, 48.00:1	
	25A376	LAC ; 0.5 hp, 150.06:1	
	24Z037	MPM , 2.2 hp, BLDC	1
5‡	— — —	SEAL, rotary shaft, rear	1
6‡	24Y844	MOTOR OUTPUT SHAFT, kit	1
7‡	— — —	RING, retaining, internal, 120 mm	1
8‡	— — —	SEAL, rotary shaft, front	1
9	24Y840	ECCENTRIC SHAFT (driver assembly), kit; includes ref. 10	1
10	— — —	RING, retaining, external, 50 mm; included with ref. 9	1
11	24Y796	ROLLER ASSEMBLY, kit, includes refs. 12 and 13	1
12	— — —	RING, retaining, external, 45 mm	1
13a, 13b	24Y847	SEALS, rotary shaft, front and back	1 ea.
14		HOSE, 30 mm, for ST30	1
	24Y809	Natural Rubber, black	
	24Y810	CSM, orange	
	24Y811	EPDM, blue	
	24Y812	Nitrile, yellow	
		HOSE, 32 mm, for ST32	1
	19C746	Natural Rubber, black	
	19C748	CSM, orange	
	19C749	EPDM, blue	
	19C747	Nitrile, yellow	
	19C750	HOSE, 32 mm, Food Grade, for ST32FG	1
15*†	— — —	GASKET, front cover	1
16*		FRONT COVER, kit	1
	24Y832	for ST30	
	19D482	for ST32	
	19C914	for ST32FG	
17*	121110	O-RING	2

ST30, ST32, and ST32FG Parts			
Ref	Part	Description	Qty
18*	C20242	O-RING	1
19*	17C529	HANDLE, cover	2
20*	17C608	SIGHTGLASS	1
21	16Y267	WASHER, flat, M10	10
22*	124164	SCREW, M6-1.0 x 25mm, stainless steel	8
23*	124313	SCREW, M6-1 x 16mm, stainless steel	6
24	24Y828	CLAMP, hose, size 32	2
25†	— — —	GASKET, hose plate	2
26	17B696	PLATE, hose barb	2
27■	17B692	FLANGE, hose barb	2
28		BARB, kit, for ST30 ; includes o-ring (ref. 44)	2
	24Y822	Stainless steel	
	24Y823	PVDF	
	24Y824	Hastelloy	
		BARB, kit, for ST32 ; includes o-ring (ref. 44)	2
	19C909	Stainless steel	
	19C920	PVDF	
	19C911	BARB, kit, for ST32FG ; includes o-ring (ref. 44)	2
29*	16K274	PLUG, hex, 3/4 npt	1
30*	16K281	VENT, breather, muffler, 3/4 npt	1
31	16Y268	SCREW, cap, hex head, M10-1.5 x 25mm	10
32▲	16K630	LABEL, warning	1
33	110208	PLUG, pipe, headless	1
34	— — —	STUD, M8, fastener	8
35	17G188	NUT, lock, hex, flange,	8
42▲	15J075	LABEL, warning	1
43	Δ	LUBRICANT	1
44	107249	O-RING; included with ref. 28	2
45*	16K729	SCREW, flange head, M8-1.25 x 25mm	10
52*	16K738	WASHER, lock, spring	10
53*	112914	WASHER, flat	10
54	24Y445	GRACO MOTOR CONTROL; used on MPM (BLDC) pumps	1

ST30, ST32, and ST32FG Parts			
Ref	Part	Description	Qty
55	15Y051	CABLE, M12, 8 pin, m/f, 3.0 m (9.8 ft); used on MPM (BLDC) pumps	1
56‡	17C577	KEY, eccentric shaft	1
57	25A840	KEY, motor output shaft	1
58	116343	SCREW, ground	1
59	17B596	TOOL, BLDC, shaft socket	1

ST30, ST32, and ST32FG Parts			
Ref	Part	Description	Qty
60	24Z041	GEARBOX, BLDC	1
61	— — —	SCREW, cap, hex hd, 3/8–16 x 1, grade 8.8	4
62	— — —	WASHER, lock, 3/8	4
63	— — —	WASHER, flat, 3/8	4

Notes for [ST30](#), [ST32](#), and [ST32FG](#) Parts:

▲ Replacement Danger and Warning labels, tags, and cards are available at no cost.

— — — Not sold separately.

* Parts included in Front Cover Kit, Ref. 16.

† Parts included in Gasket Kit 24Y836.

‡ Parts included in Main Shaft Kit 24Y844.

△ See [Lubricate the Pump, page 18](#) for ordering information.

■ Not used in food grade pump models.

Kits and Accessories

For AC and BLDC Motors

Leak Sensor Kit 24Y849

Upgrade kit, to add a leak sensor to an existing system. Includes leak sensor and housing.

NOTE: Also purchase a cable from the following selections. For systems with BLDC motors that use a Graco Motor Control, order an extension cable from the first section. For systems with AC motors that use a VFD, order a field-wireable cable from the second section.

Leak Sensor/PLC Extension Cables (For BLDC Motors)

M8, 4-pin

Part	Description
121683	9.8 ft; 3.0 m
17H349	24.6 ft; 7.5 m
17H352	52.5 ft; 16 m

Leak Sensor Cables; Field Wireable (for VFDs)

M8, 4-pin

Part	Description
17H389	9.8 ft; 3.0 m
17H390	24.6 ft; 7.5 m
17H391	52.5 ft; 16 m

Controller-to-Motor Cables

Preassembled cable to wire the motor controller to the motor. Includes cable, strain reliefs, and terminals.

Part	Description
17L368	1.0 ft; 0.3 m
17S306	9.8 ft; 3.0 m

For BLDC Motors

Graco Motor Control Kit 24Y445

Replacement kit includes Graco Motor Control with necessary software.

Software Upgrade Kit 17H103

Upgrade kit includes software token and instructions.

NOTE: Also purchase Programming Cable Kit 24Y788.

Motor Feedback Cables

M12, 8-pin

Part	Description
17F709	1.0 ft; 0.3 m
15Y051	9.8 ft; 3.0 m
16X521	24.6 ft; 7.5 m
16P791	52.5 ft; 16 m

PLC Control Cable

M8, 4-pin

Part	Description
17H365	9.8 ft; 3.0 m
17H366	24.6 ft; 7.5 m
17H367	52.5 ft; 16 m

Technical Data

SoloTech Peristaltic Pumps		
	U.S.	Metric
Maximum Fluid Working Pressure	125 psi	0.9 MPa, 9 bar
Motor Horsepower/Gear Ratio	See the identification tag on your gear motor.	
Maximum Pump Speed, using a Graco BLDC motor	90 RPM	
Environmental Temperature Range (Do not allow material to freeze in the pump.)	14°F to 104°F	-10°C to 40°C
Maximum Flow		
ST6	0.25 gpm	0.95 lpm
ST10	0.67 gpm	2.5 lpm
ST23	4.5 gpm	17.0 lpm
ST25FG	5.2 gpm	19.6 lpm
ST26	9.8 gpm	37.1 lpm
ST26FG	9.3 gpm	35.1 lpm
ST30	15.8 gpm	59.8 lpm
ST32	17.7 gpm	67.0 lpm
Fluid Capacity per Revolution		
ST6	0.003 gal.	0.01 L
ST10	0.007 gal.	0.03 L
ST23	0.054 gal.	0.20 L
ST25FG	0.058 gal.	0.218 L
ST26	0.11 gal.	0.42 L
ST26FG	0.10 gal.	0.39 L
ST30	0.18 gal.	0.68 L
ST32	0.20 gal.	0.74 L
Flange Dimensions		
ST6 and ST10		
Outer Diameter	3.54 in.	90 mm
Bolt Circle	2.30–2.56 in.	58–65 mm
Bolt Size	1/2 in.	
ST23, ST25FG, and ST26		
Outer Diameter	4.25 in.	108 mm
Bolt Circle	2.95–3.13 in.	75–80 mm
Bolt Size	1/2 in.	
ST30 and ST32		
Outer Diameter	4.92 in.	125 mm
Bolt Circle	3.35–3.54 in.	85–90 mm
Bolt Size	1/2 in.	

Technical Data

SoloTech Peristaltic Pumps		
	U.S.	Metric
Hose Inner Diameter		
ST6	0.24 in.	6 mm
ST10	0.39 in.	10 mm
ST23	0.91 in.	23 mm
ST25FG	0.98 in.	25 mm
ST26	1.02 in.	26 mm
ST26FG	0.98 in.	25 mm
ST30	1.18 in.	30 mm
ST32	1.26 in.	32 mm
Weight		
ST6 and ST10	55–65 lbs	25–29 kg
ST23 and ST25FG	100–120 lbs.	45–54 kg
ST26	190–215 lbs.	86–98 kg
ST30 and ST32	235–285 lbs	107–129 kg
Noise		
Sound Pressure	Less than 70 dB(A)	
Wetted Parts		
Hose options	Natural Rubber, CSM, EPDM, NBR	
Barbed fitting options	Stainless steel, PVDF, Hastelloy	

Graco Motor Control for SoloTech Peristaltic Pumps		
(All installations and wiring must comply with NEC and local electrical codes.)		
DC Power Supply	Class 2 Power Supply only	
Approvals	UL508C	
Conformity	CE-Low Voltage (2006/95/EC), EMC (2004/108/EC), and RoHS (2011/65/EU) Directives	
Ambient Temperature	-40°F – 104°F	-40°C – 40°C
Environment Rating	Type 4X, IP 66	
Overtemperature Sensing Specifications (The drive is provided with a means to accept and act upon a signal from a thermal sensor in the motor. Motor overtemperature sensing is required to provide the motor overload protection.)	0–3.3 VDC, 1mA maximum	
Weight	10.5 lb.	4.8 kg
Input Specifications		
Input Line Voltage	120/240 VAC, line-to-line	
Input Line Phasing	Single Phase	
Input Line Frequency	50/60 Hz	
Input Current per Phase	16A	
Maximum Branch Circuit Protection Rating	20A, Inverse Time Circuit Breaker	
Short Circuit Current Rating	5 kA	
Output Specifications		
Output Line Voltage	0–264 VAC	
Output Line Phasing	Three Phase	
Output Current (Current limit, set via the software, is provided as a secondary protection from motor overload.)	0–12A	
Output Power	1.92 KW / 2.6 hp	
Output Overload	200% for 0.2 seconds	

Electric Motor for SoloTech Peristaltic Pumps

Motor	Configuration Code	Pump Size	Gear Ratio	Pump Shaft Diameter	Gearmotor Flange Diameter	Maximum Torque (in.-lb (N·m))	Power	Output Speed (RPM)	Maximum Amperage Load	Voltage and Frequency	IP Rating	IE Rating	Poles	Mounting Flange	Constant Torque	Nominal Speed at 50 Hz	Nominal Speed at 60 Hz		
AC Gearmotors	HAC	ST6, ST10	20	20 mm	120 mm	434 (49)	0.75 HP (0.56 kW)	15-90	2.70/1.35 (230 V/460 V)	230/460 VAC, 3-phase, 50/60 Hz	IP66	IE1	4-Pole	---	---	---	---		
		ST23, ST25FG	20	20 mm	120 mm	573 (65)	1.0 HP (0.75 kW)	15-90	3.14/1.57 (230 V/460 V)	230/460 VAC, 3-phase, 50/60 Hz	IP66	IE3	4-Pole	---	---	---	---		
		ST26	19.52	30 mm	160 mm	1380 (156)	2.0 HP (1.5 kW)	15-92	5.60/2.80 (230 V/460 V)	230/460 VAC, 3-phase, 50/60 Hz	IP66	IE3	4-Pole	---	---	---	---		
		ST30, ST32	24.88	35 mm	200 mm	1950 (220)	3.0HP (2.2 kW)	12-72	7.68/3.84 (230 V/460 V)	230/460 VAC, 3-phase, 50/60 Hz	IP66	IE3	4-Pole	---	---	---	---		
	MAC	ST6, ST10	48	20 mm	120 mm	660 (75)	0.5 HP (0.37 kW)	6-38	1.90/0.95 (230 V/460 V)	230/460 VAC, 3-phase, 50/60 Hz	IP66	IE1	4-Pole	---	---	---	---	---	
		ST23, ST25FG	48	20 mm	120 mm	996 (113)	0.75 HP (0.56 kW)	6-38	2.70/1.35 (230 V/460 V)	230/460 VAC, 3-phase, 50/60 Hz	IP66	IE1	4-Pole	---	---	---	---	---	
		ST26	44.19	30 mm	160 mm	1610 (182)	1.0 HP (0.75 kW)	7-41	3.14/1.57 (230 V/460 V)	230/460 VAC, 3-phase, 50/60 Hz	IP66	IE3	4-Pole	---	---	---	---		
		ST30, ST32	48.56	35 mm	200 mm	2638 (298)	1.5 HP (1.1 kW)	6-37	4.20/2.10 (230 V/460 V)	230/460 VAC, 3-phase, 50/60 Hz	IP66	IE3	4-Pole	---	---	---	---		
	LAC	ST6, ST10, ST23, ST25FG	120	20 mm	120 mm	647 (73)	0.25 HP (0.19 kW)	3-15	1.12/0.56 (230 V/460 V)	230/460 VAC, 3-phase, 50/60 Hz	IP66	IE1	4-Pole	---	---	---	---	---	
		ST26	159.09	30 mm	160 mm	1918 (217)	0.33 HP (0.25 kW)	2-11	1.56/0.78 (230 V/460 V)	230/460 VAC, 3-phase, 50/60 Hz	IP66	IE1	4-Pole	---	---	---	---	---	
		ST30, ST32	159.09	35 mm	200 mm	2906 (328)	0.5HP (0.37 kW)	2-11	1.90/0.95 (230 V/460 V)	230/460 VAC, 3-phase, 50/60 Hz	IP66	IE1	4-Pole	---	---	---	---	---	
	BLDC Gearmotors	MPM	ST6, ST10, ST23, ST25FG	36.75	---	---	---	1.0HP (0.75 kW)	2-90	2.6 (230 V/460 V)	320 VDC	IP56	---	---	NEMA 56C	---	---	---	---
ST26			38.67	---	---	---	2.2HP (1.6 kW)	2-90	5.2 (230 V/460 V)	320 VDC	IP56	---	---	NEMA 56C	---	---	---	---	
ST30, ST32			38.67	---	---	---	2.2HP (1.6 kW)	2-90	5.2 (230 V/460 V)	320 VDC	IP56	---	---	NEMA 56C	---	---	---	---	
Gearboxes	HC	ST6, ST10	19.56	20 mm	120 mm	770 (87)	---	---	---	---	---	---	---	IEC 71	---	---	---	---	
		ST23, ST25FG	19.56	20 mm	120 mm	770 (87)	---	---	---	---	---	---	---	IEC 80	---	---	---	---	
		ST26	18.75	30 mm	160 mm	2151 (243)	---	---	---	---	---	---	---	IEC 90	---	---	---	---	
		ST30, ST32	24.88	35 mm	200 mm	3213 (363)	---	---	---	---	---	---	---	IEC 100	---	---	---	---	
	HN	ST6, ST10	19.56	20 mm	120 mm	770 (87)	---	---	---	---	---	---	---	---	NEMA 56C	---	---	---	---
		ST23, ST25FG	19.56	20 mm	120 mm	770 (87)	---	---	---	---	---	---	---	---	NEMA 140TC	---	---	---	---
		ST30, ST32	24.88	35 mm	200 mm	3213 (363)	---	---	---	---	---	---	---	---	NEMA 180TC	---	---	---	---
	MC	ST6, ST10, ST23, ST25FG	59.83	20 mm	120 mm	885 (100)	---	---	---	---	---	---	---	---	IEC 71	---	---	---	---

Electric Motor for SoloTech Peristaltic Pumps																		
Motor	Config-uration Code	Pump Size	Gear Ratio	Pump Shaft Di- ameter	Gearmotor Flange Diameter	Maxi- mum Torque (in.-lb (N·m))	Power	Output Speed (RPM)	Maximum Amperage Load	Voltage and Frequency	IP Rating	IE Rating	Poles	Moun- ting Fla- nge	Const- ant Tor- que	Nom- inal Speed at 50 Hz	Nom- inal Speed at 60 Hz	
		ST26	44.4	30 mm	160 mm	2151 (243)	---	---	---	---	---	---	---	IEC 80	---	---	---	
		ST30, ST32	44.4	35 mm	200 mm	2982 (337)	---	---	---	---	---	---	---	IEC 80	---	---	---	
	MN		ST6, ST10, ST23, ST25FG	59.83	20 mm	120 mm	885 (100)	---	---	---	---	---	---	---	NEMA 56C	---	---	---
			ST26	44.4	30 mm	160 mm	2151 (243)	---	---	---	---	---	---	---	NEMA 140TC	---	---	---
			ST30, ST32	44.4	35 mm	200 mm	2982 (337)	---	---	---	---	---	---	---	NEMA 140TC	---	---	---
	LC		ST6, ST10, ST23, ST25FG	128.7	20 mm	120 mm	938 (106)	---	---	---	---	---	---	---	IEC 71	---	---	---
			ST26	158.12	30 mm	160 mm	3275 (370)	---	---	---	---	---	---	---	IEC 71	---	---	---
			ST30, ST32	158.12	35 mm	200 mm	3275 (370)	---	---	---	---	---	---	---	IEC 71	---	---	---
	LN		ST6, ST10, ST23, ST25FG	128.7	20 mm	120 mm	938 (106)	---	---	---	---	---	---	---	NEMA 56C	---	---	---
			ST26	158.12	30 mm	160 mm	3275 (370)	---	---	---	---	---	---	---	NEMA 56C	---	---	---
			ST30, ST32	158.12	35 mm	200 mm	3275 (370)	---	---	---	---	---	---	---	NEMA 56C	---	---	---
	AC Mo- tors, ATEX		ST6, ST10	---	---	---	---	0.5 HP (0.37 kW)	---	1.84/1.06 (240 V/415 V)	240/415 V, 3-phase, 50/60 Hz	IP55	IE1	4-Pole	IEC 71	5:1	1500	1800
ST23, ST25FG			---	---	---	---	1.0 HP (0.75 kW)	---	3.46/2.00 (240 V/415 V)	240/415 V, 3-phase, 50/60 Hz	IP55	IE1	4-Pole	IEC 80	10:1	1500	1800	
ST26			---	---	---	---	2.0 HP (1.5 kW)	---	5.89/3.40 (240 V/415 V)	240/415 V, 3-phase, 50/60 Hz	IP55	IE1	4-Pole	IEC 90	10:1	1500	1800	
ST30, ST32			---	---	---	---	3.0 HP (2.2 kW)	---	8.66/5.00 (240 V/415 V)	240/415 V, 3-phase, 50/60 Hz	IP55	IE1	4-Pole	IEC 100	10:1	1500	1800	
AC Mo- tors, Explo- sion proof		ST6, ST10, ST23, ST25FG	---	---	---	---	0.5 HP (0.37 kW)	---	1.94/0.97 (230 V/460 V)	230/460 V, 3-phase, 50/60 Hz	IP55	IE1	4-Pole	NEMA 56C	5:1	1500	1800	
		ST26	---	---	---	---	1.0 HP (0.75 kW)	---	3.88/1.94 (230 V/460 V)	230/460 V, 3-phase, 50/60 Hz	IP55	IE3	4-Pole	NEMA 143TC	10:1	1500	1800	
		ST30, ST32	---	---	---	---	3.0 HP (2.2 kW)	---	8.60/4.30 (230 V/460 V)	230/460 V, 3-phase, 50/60 Hz	IP55	IE3	4-Pole	NEMA 182TC	10:1	1500	1800	

--- Not available.

Optional Leak Sensor	
Contact Ratings:	
State	Normally open
Voltage	200 VAC/VDC max.
Current	1.25 A DC or peak AC
Power	10 W max
Ambient Temperature	-5°C to 80°C (23°F to 176°F)
Ex Ratings:	
Classification	<p>"simple apparatus" in accordance with UL/EN/IEC 60079-11, clause 5.7</p> <p>Class I, Div 1, Group A, B, C, D T4 -5°C T_a 80°C</p> <p> II 1 G Ex ia IIC T4 Ga -5°C T_a 80°C</p>
Parameters	<p>U_i = 24 V I_i = 280 mA P_i = 1.0 W C_i = 2.8 pF L_i = 0.8 μH</p>

Maximum Fluid Temperature

NOTICE

Temperature limits are based on mechanical stress only. Certain chemicals will further limit the fluid temperature range. Stay within the temperature range of the most-restricted wetted component. Operating at a fluid temperature that is too high or too low for the components of your pump may cause equipment damage.

Hose	Fahrenheit (max)	Celsius (max)
Natural Rubber	160°F	71°C
CSM	250°F	121°C
EPDM	220°F	104°C
Nitrile (NBR) and Food Grade Nitrile	250°F	121°C

Notes

Graco Standard Warranty

Graco warrants all equipment referenced in this document which is manufactured by Graco and bearing its name to be free from defects in material and workmanship on the date of sale to the original purchaser for use. With the exception of any special, extended, or limited warranty published by Graco, Graco will, for a period of twelve months from the date of sale, repair or replace any part of the equipment determined by Graco to be defective. This warranty applies only when the equipment is installed, operated and maintained in accordance with Graco's written recommendations.

This warranty does not cover, and Graco shall not be liable for general wear and tear, or any malfunction, damage or wear caused by faulty installation, misapplication, abrasion, corrosion, inadequate or improper maintenance, negligence, accident, tampering, or substitution of non-Graco component parts. Nor shall Graco be liable for malfunction, damage or wear caused by the incompatibility of Graco equipment with structures, accessories, equipment or materials not supplied by Graco, or the improper design, manufacture, installation, operation or maintenance of structures, accessories, equipment or materials not supplied by Graco.

This warranty is conditioned upon the prepaid return of the equipment claimed to be defective to an authorized Graco distributor for verification of the claimed defect. If the claimed defect is verified, Graco will repair or replace free of charge any defective parts. The equipment will be returned to the original purchaser transportation prepaid. If inspection of the equipment does not disclose any defect in material or workmanship, repairs will be made at a reasonable charge, which charges may include the costs of parts, labor, and transportation.

THIS WARRANTY IS EXCLUSIVE, AND IS IN LIEU OF ANY OTHER WARRANTIES, EXPRESS OR IMPLIED, INCLUDING BUT NOT LIMITED TO WARRANTY OF MERCHANTABILITY OR WARRANTY OF FITNESS FOR A PARTICULAR PURPOSE.

Graco's sole obligation and buyer's sole remedy for any breach of warranty shall be as set forth above. The buyer agrees that no other remedy (including, but not limited to, incidental or consequential damages for lost profits, lost sales, injury to person or property, or any other incidental or consequential loss) shall be available. Any action for breach of warranty must be brought within two (2) years of the date of sale.

GRACO MAKES NO WARRANTY, AND DISCLAIMS ALL IMPLIED WARRANTIES OF MERCHANTABILITY AND FITNESS FOR A PARTICULAR PURPOSE, IN CONNECTION WITH ACCESSORIES, EQUIPMENT, MATERIALS OR COMPONENTS SOLD BUT NOT MANUFACTURED BY GRACO. These items sold, but not manufactured by Graco (such as electric motors, switches, hose, etc.), are subject to the warranty, if any, of their manufacturer. Graco will provide purchaser with reasonable assistance in making any claim for breach of these warranties.

In no event will Graco be liable for indirect, incidental, special or consequential damages resulting from Graco supplying equipment hereunder, or the furnishing, performance, or use of any products or other goods sold hereto, whether due to a breach of contract, breach of warranty, the negligence of Graco, or otherwise.

FOR GRACO CANADA CUSTOMERS

The Parties acknowledge that they have required that the present document, as well as all documents, notices and legal proceedings entered into, given or instituted pursuant hereto or relating directly or indirectly hereto, be drawn up in English. Les parties reconnaissent avoir convenu que la rédaction du présente document sera en Anglais, ainsi que tous documents, avis et procédures judiciaires exécutés, donnés ou intentés, à la suite de ou en rapport, directement ou indirectement, avec les procédures concernées.

Graco Information

To place an order, contact your Graco Distributor or call to identify the nearest distributor.

Phone: 612-623-6921 **or Toll Free:** 1-800-328-0211 **Fax:** 612-378-3505

All written and visual data contained in this document reflects the latest product information available at the time of publication. Graco reserves the right to make changes at any time without notice.

Original Instructions. This manual contains English, MM 3A3367
For patent information, see www.graco.com/patents.

Graco Headquarters: Minneapolis
International Offices: Belgium, China, Japan, Korea

GRACO INC. AND SUBSIDIARIES • P.O. BOX 1441 • MINNEAPOLIS, MN 55440-1441 • USA
Copyright 2015, Graco Inc. All Graco manufacturing locations are registered to ISO 9001.

www.graco.com

Revision K, September 2021