

# 1:1 Extruder

3A5224D

EN

**Supply, metering, and dispense system for 5 gallon (20 liter) pails. For professional use only.**

**Not approved for use in European explosive atmosphere locations.**

## **Part No. 25C861**

1:1 Liquid Silicone Rubber Extruder

## **Part No. 25C862**

1:1 Carbon Steel Extruder

## **Part No. 25C863**

1:1 Stainless Steel Extruder

*3000 psi (20.7 MPa, 207 bar) Maximum Working Pressure*



### **Important Safety Instructions**

Read all warnings and instructions in this manual and in all related manuals. Save these instructions.

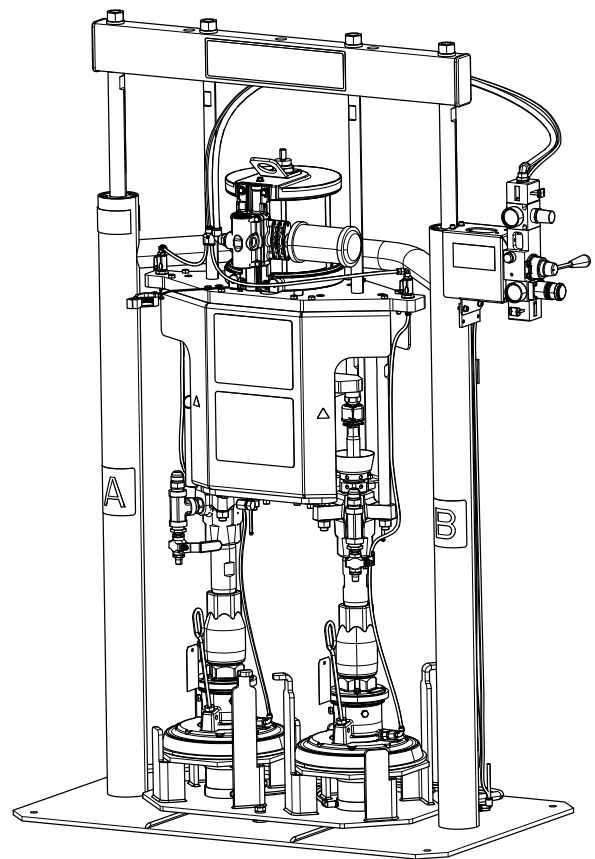

# Table of Contents

- Models . . . . . 3**
- Related Manuals . . . . . 3**
- Warnings . . . . . 4**
- Two-Component Materials . . . . . 6**
  - Keep Components A and B Separate . . . . . 6
  - Changing Materials . . . . . 6
  - A (Red) and B (Blue) Components . . . . . 6
- Component Identification . . . . . 8**
- Installation . . . . . 9**
  - Location . . . . . 9
  - Grounding . . . . . 9
  - Setup . . . . . 10
  - Flush the Equipment . . . . . 10
- Operation . . . . . 11**
  - Startup . . . . . 11
  - Prime . . . . . 12
  - Dispensing Mixed Material . . . . . 13
  - Changing Pails . . . . . 13
  - Shutdown . . . . . 14
  - Pressure Relief Procedure . . . . . 14
- Maintenance . . . . . 15**
- Troubleshooting . . . . . 16**
- Parts . . . . . 17**
- Dimensions . . . . . 23**
- Performance Chart . . . . . 24**
- Technical Specifications . . . . . 25**
  - California Proposition 65 . . . . . 25
- Graco Standard Warranty . . . . . 26**

# Models



Part No.	Maximum Working Pressure psi (MPa, bar)	Description	Approvals
25C861	3000 psi (20.7 MPa, 207 bar)	1:1 LSR Extruder, 5/5 Gallon	<b>CE</b>
25C862	3000 psi (20.7 MPa, 207 bar)	1:1 CS Extruder, 5/5 Gallon	
25C863	3000 psi (20.7 MPa, 207 bar)	1:1 SST Extruder, 5/5 Gallon	

## Related Manuals

Ram Manuals	
313526	Supply Systems Operation
313527	Supply Systems Repair - Parts
334198	55 Gallon (200 Liter), 16 Gallon (60 Liter), and 5 Gallon (20 Liter) Ram Modules Repair-Parts
Pump Manuals	
312375	Check-Mate® Displacement Pumps Instructions - Parts
312376	Check-Mate® Pump Packages - Instructions - Parts
Air Motor Manuals	
3A1211	SaniForce® Air Motors Instructions - Parts
Air Controls Manuals	
312374	Air Controls Instructions - Parts

# Warnings

The following warnings are for the setup, use, grounding, maintenance, and repair of this equipment. The exclamation point symbol alerts you to a general warning and the hazard symbols refer to procedure-specific risks. When these symbols appear in the body of this manual or on warning labels, refer back to these Warnings. Product-specific hazard symbols and warnings not covered in this section may appear throughout the body of this manual where applicable.

 <h2 style="margin: 0;">WARNING</h2>	
	<p><b>SKIN INJECTION HAZARD</b></p> <p>High-pressure fluid from dispensing device, hose leaks, or ruptured components will pierce skin. This may look like just a cut, but it is a serious injury that can result in amputation. <b>Get immediate surgical treatment.</b></p> <ul style="list-style-type: none"> <li>• Do not point the dispensing device at anyone or at any part of the body.</li> <li>• Do not put your hand over the fluid outlet.</li> <li>• Do not stop or deflect leaks with your hand, body, glove, or rag.</li> <li>• Follow the <b>Pressure Relief Procedure</b> when you stop dispensing and before cleaning, checking, or servicing equipment.</li> <li>• Tighten all fluid connections before operating the equipment.</li> <li>• Check hoses and couplings daily. Replace worn or damaged parts immediately.</li> </ul>
	<p><b>MOVING PARTS HAZARD</b></p> <p>Moving parts can pinch, cut or amputate fingers and other body parts.</p> <ul style="list-style-type: none"> <li>• Keep clear of moving parts.</li> <li>• Do not operate equipment with protective guards or covers removed.</li> <li>• Pressurized equipment can start without warning. Before checking, moving, or servicing equipment, follow the <b>Pressure Relief Procedure</b> and disconnect all power sources.</li> </ul>

# ! WARNING



## FIRE AND EXPLOSION HAZARD

Flammable fumes, such as solvent and paint fumes, in **work area** can ignite or explode. Paint or solvent flowing through the equipment can cause static sparking. To help prevent fire and explosion:



- Use equipment only in well ventilated area.
- Eliminate all ignition sources; such as pilot lights, cigarettes, portable electric lamps, and plastic drop cloths (potential static sparking).
- Ground all equipment in the work area. See **Grounding** instructions.
- Never spray or flush solvent at high pressure.
- Keep work area free of debris, including solvent, rags and gasoline.
- Do not plug or unplug power cords, or turn power or light switches on or off when flammable fumes are present.
- Use only grounded hoses.
- Hold gun firmly to side of grounded pail when triggering into pail. Do not use pail liners unless they are anti-static or conductive.
- **Stop operation immediately** if static sparking occurs or you feel a shock. Do not use equipment until you identify and correct the problem.
- Keep a working fire extinguisher in the work area.



## TOXIC FLUID OR FUMES HAZARD

Toxic fluids or fumes can cause serious injury or death if splashed in the eyes or on skin, inhaled, or swallowed.

- Read Safety Data Sheet (SDS) to know the specific hazards of the fluids you are using.
- Store hazardous fluid in approved containers, and dispose of it according to applicable guidelines.



## PERSONAL PROTECTIVE EQUIPMENT

Wear appropriate protective equipment when in the work area to help prevent serious injury, including eye injury, hearing loss, inhalation of toxic fumes, and burns. Protective equipment includes but is not limited to:

- Protective eyewear, and hearing protection.
- Respirators, protective clothing, and gloves as recommended by the fluid and solvent manufacturer.



## EQUIPMENT MISUSE HAZARD

Misuse can cause death or serious injury.



- Do not operate the unit when fatigued or under the influence of drugs or alcohol.
- Do not exceed the maximum working pressure or temperature rating of the lowest rated system component. See **Technical Specifications** in all equipment manuals.
- Use fluids and solvents that are compatible with equipment wetted parts. See **Technical Specifications** in all equipment manuals. Read fluid and solvent manufacturer's warnings. For complete information about your material, request Safety Data Sheet (SDS) from distributor or retailer.
- Do not leave the work area while equipment is energized or under pressure.
- Turn off all equipment and follow the **Pressure Relief Procedure** when equipment is not in use.
- Check equipment daily. Repair or replace worn or damaged parts immediately with genuine manufacturer's replacement parts only.
- Do not alter or modify equipment. Alterations or modifications may void agency approvals and create safety hazards.
- Make sure all equipment is rated and approved for the environment in which you are using it.
- Use equipment only for its intended purpose. Call your distributor for information.
- Route hoses and cables away from traffic areas, sharp edges, moving parts, and hot surfaces.
- Do not kink or over bend hoses or use hoses to pull equipment.
- Keep children and animals away from work area.
- Comply with all applicable safety regulations.

# Two-Component Materials

## Keep Components A and B Separate



Cross-contamination can result in cured material in fluid lines which could cause serious injury or damage equipment. To prevent cross-contamination:

- Never interchange component A and component B wetted parts.
- Never use solvent on one side if it has been contaminated from the other side.

## A (Red) and B (Blue) Components

**NOTE:** Material suppliers can vary in how they refer to plural component materials.

Be aware that when standing in front of the proportioner:

- Component A (Red) is on the left side.
- Component B (Blue) is on the right side.

## Changing Materials

Changing the material types used in your equipment requires special attention to avoid equipment damage and downtime.

- When changing materials, flush the equipment multiple times to ensure it is thoroughly clean.
- Always clean the fluid inlet strainers after flushing.
- Check with your material manufacturer for chemical compatibility.
- When changing between epoxies and urethanes or polyureas, disassemble and clean all fluid components and change hoses. Epoxies often have amines on the B (hardener) side. Polyureas often have amines on the B (resin) side.



# Component Identification

25C861 Shown

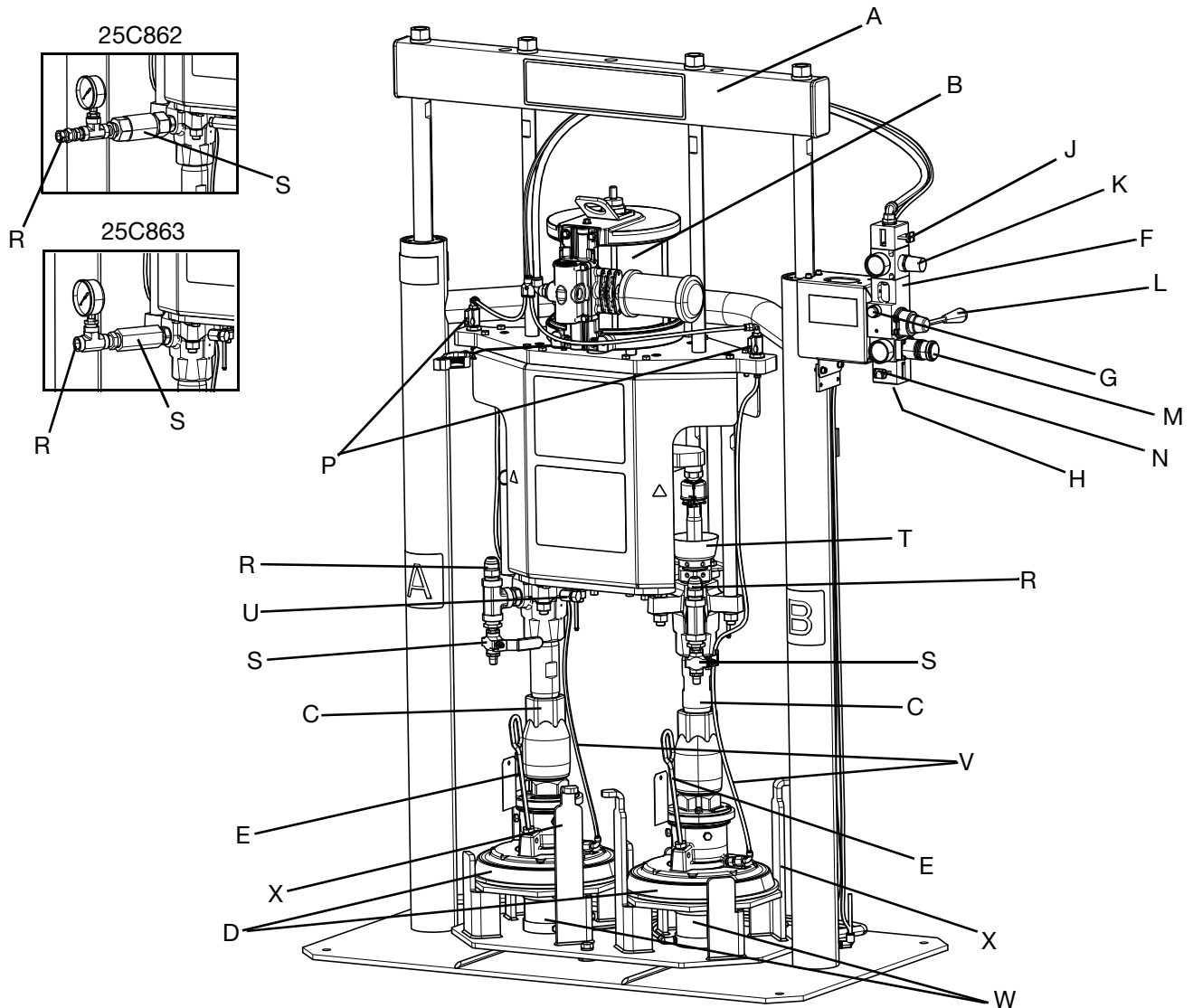

**FIG. 1: 1:1 Extruder Components**



**Key:**

- |   |                           |   |  |
|---|---------------------------|---|--|
| A | Ram Assembly              | M | Ram Air Regulator  |
| B | Air Motor                 | N | Main Air Slider Valve  |
| C | Displacement Pumps        | P | Pail Release Valves  |
| D | Platens                   | R | Material Hose Connections  |
| E | Platen Bleed Stick        | S | Material Outlet Ball Valve (25C861)<br>Material Outlet Check Valve (25C862 and 25C863) |
| F | Integrated Air Controls   | T | Displacement Pump Wet Cup  |
| G | Blow-off Button           | U | Pump Bleeder Valve   |
| H | Air Inlet                 | V | Blow-off Air Supply Lines  |
| J | Air Motor Slider Valve    | W | Pail Levelers  |
| K | Air Motor Regulator       | X | Frame Pail Locator   |
| L | Ram Director Valve Handle |   |  |



# Installation

## Location

				
To avoid personal injury or damage to the machine, always lift the supply system at the proper lift locations. Do not lift in any other way.				

Attach a lifting sling at the proper lift spots as shown in **Figure 2**. Lift off the pallet using a crane or a forklift.

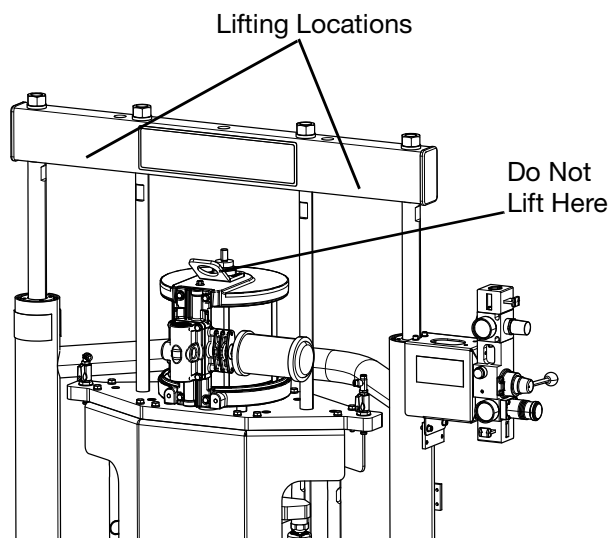

**FIG. 2: Lifting the Machine**



**NOTE:** Do not lift the machine using the ring at the top of the air motor.

Position the machine so the air controls are easily accessible. Ensure that there is enough space overhead for the ram (A) to raise fully. See **Dimensions** on page **23**.

Using the holes in the ram base as a guide, drill holes for 1/2 in. (13 mm) anchors.

Ensure that the ram base is level in all directions. If necessary, level the base using metal shims. Secure the base to the floor using 1/2 in. (13 mm) anchors that are long enough to prevent the ram from tipping.

## Grounding

				
The equipment must be grounded to reduce the risk of static sparking. Static sparking can cause fumes to ignite or explode. Grounding provides an escape wire for the electric current.				

**Pump:** use the ground wire and clamp provided. Verify that the ground screw is attached and tightened securely to the bottom of the air motor. Connect the ground clamp to a true earth ground

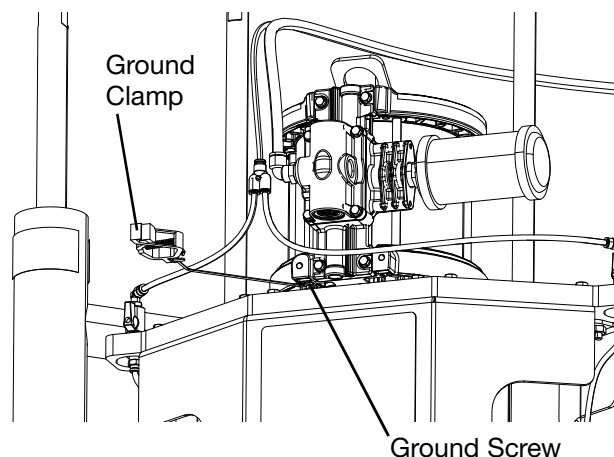

**FIG. 3: Grounding Connection**

**Air and fluid hoses:** use only electrically conductive hoses with a maximum of 500 ft. (150 m) combined hose length to ensure grounding continuity. Check electrical resistance of hoses. If total resistance to ground exceeds 29 megohms, replace hose immediately.

**Air compressor:** follow manufacturer's recommendations.

**Dispensing device:** ground through connection to a properly grounded fluid hose and pump.

**Fluid supply container:** follow local code.

**Object being sprayed:** follow local code.

**Solvent pails used when flushing:** follow local code. Use only conductive metal pails, placed on a grounded surface. Do not place the pail on a nonconductive surface, such as paper or cardboard, which interrupts grounding continuity.

**To maintain grounding continuity when flushing or relieving pressure:** hold the metal part of the dispensing device firmly to the side of a grounded metal pail, then trigger the dispensing device.

## Setup



Moving parts can pinch or amputate fingers. To avoid personal injury, do not supply air to the machine while making the air supply connections. Do not pressurize the system until you have verified the system is ready and it is safe to do so.

1. Fill the displacement pump wet cup (T) on each pump 2/3 full with Graco Throat Seal Liquid (TSL).
2. Back off both of the air regulators on the integrated air controls (F) to their full counterclockwise position, ensure the air slider valves are in the closed positions, and close all shutoff valves on the machine.
3. Connect a 1/2 in. (12.7 mm) air hose from an air source to the main air inlet connection (H) on the air control.

**NOTE:** The 1:1 Extruder system exhausts compressed air. Make sure that the air source is free of gases or other hazardous substances.

4. Connect material hoses to the hose connections (R) on the machine. The type of connection depends on the 1:1 Extruder model you are using. See **Technical Specifications** on page 25 for information.

## Flush the Equipment



To avoid fire and explosion, always ground equipment and waste container. To avoid static sparking and injury from splashing, always flush at the lowest possible pressure.



The equipment was tested with lightweight oil, which is left in the fluid passages to protect parts. To avoid contaminating your fluid with oil, flush the equipment with a compatible solvent before using the equipment.





Additionally:

- Flush before storing and before repairing equipment, if needed.
- Flush at the lowest pressure possible. Check connectors for leaks and tighten as necessary.
- Flush with a fluid that is compatible with the fluid being dispensed and the equipment wetted parts.

See the pump manuals referenced in **Related Manuals** on page 3 for flushing directions.

# Operation

				
<p>Keep your fingers, hands, and tools away from the priming piston and the yoke assembly during operation and whenever the pump air and fluid pressure is not fully relieved.</p> <p>Be sure that all shields covering moving parts are installed and safety devices are operating properly before each use.</p>				

				
<p>Mechanically linked pumps can create excessive fluid pressure if the full motor force is applied to only one of the fluid pumps. Never operate one pump alone. Do not disconnect one pump or allow a pump to run out of material. The system is designed to have both pumps run together. Running one pump alone could put too much stress on the hardware that connects the air motor to the displacement pumps and could cause the hardware to fracture.</p>				

To prevent excessive wear and heat generation, do not operate the 1:1 Extruder above 30 cycles per minute for an extended period of time.

**NOTE:** The ram director valve handle (L) is used to raise and lower the ram. Put the handle in the neutral position as shown in **Figure 4** to stop the ram from raising or lowering and to prevent any unintended movement.

# Startup

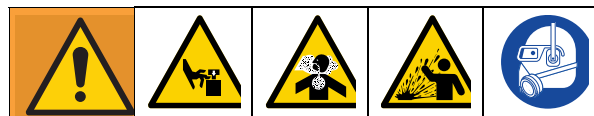

1. Turn on the air supply to the machine by sliding the main air slider valve (N) on the air control to the open position.

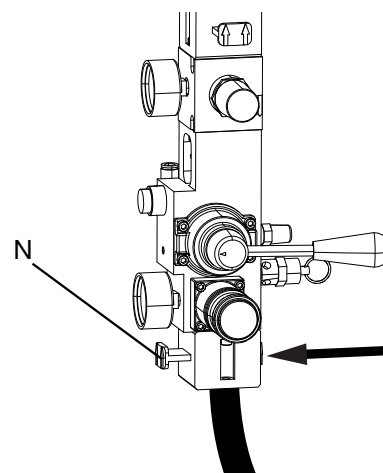

**FIG. 4: Open Main Air Slider Valve**

2. Set the ram air regulator (M) to 10 psi (0.07 MPa, 0.7 bar).
3. Lift the ram director valve handle (L) to raise the ram to full height, adjusting the ram air regulator as needed.

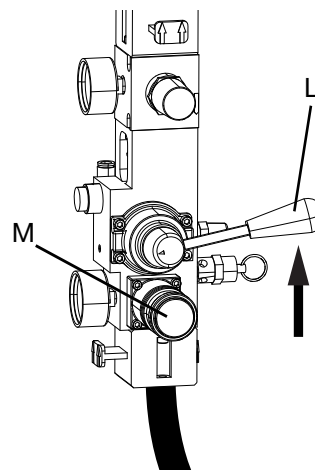
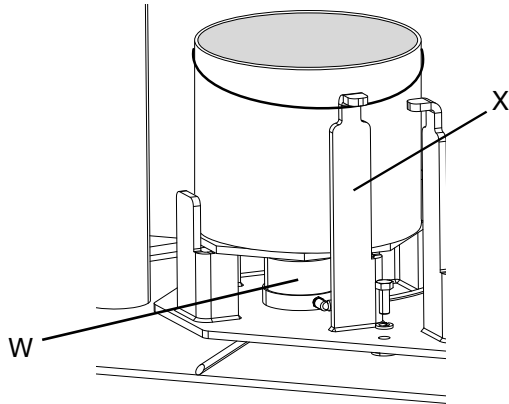

**FIG. 5: Raise Ram**

**NOTICE**

To avoid damage to the platen seals, do not use a pail that is dented or damaged

4. Open a pail of component A and one of component B. Place the pails inside the brackets on the frame assembly pail levelers (W). Hook the pail handles over the frame pail locator bracket (X).



**FIG. 6: Locate Pail**

5. Lubricate the ram platen o-rings with material from the pails you are using. Make sure you do not mix the materials when lubricating the o-rings. Use material A on side A and material B on side B.
6. Remove the platen bleed sticks (E) from the ports.

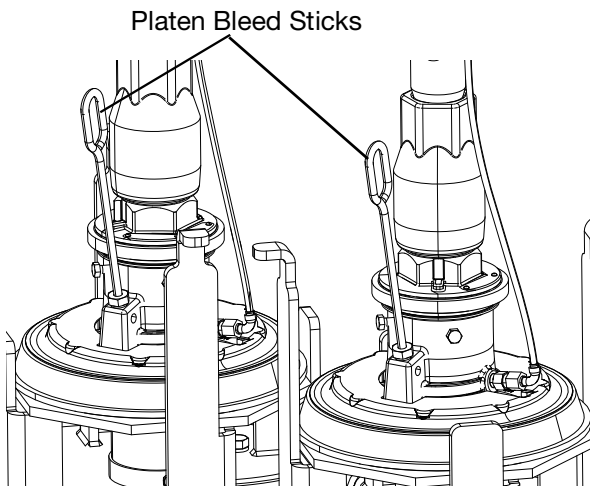

**FIG. 7: Platen Bleed Sticks**

**NOTICE**

Ensure that there is no debris on the platens to avoid damage to the platen seal and debris mixing with the material.

7. Stand clear of the pumps. Move the ram director valve handle (L) to the down position to lower the platens (D) into the pails of material.
8. When air has escaped and material starts to come out of the bleed ports, replace the bleed sticks and clean off any excess material that overflowed from the bleed ports.
9. Adjust the ram air pressure as needed.

**Prime**

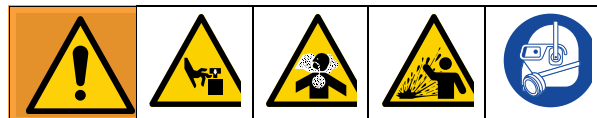

**NOTE:** Ensure that hoses are connected to the material hose connections and that all of the valves except the main air slider valve on the machine are closed prior to starting this procedure. Refer to **Figure 1** on page 8.

1. Set the air motor regulator (K) to 10 psi (0.07 MPa, 0.7 bar).
2. Open the air motor slider (J) valve on the air control.

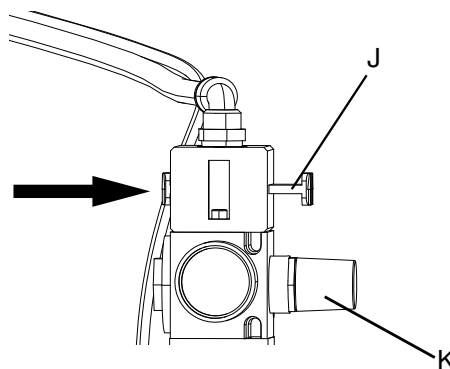

**FIG. 8: Air Motor Controls**

3. Slowly increase air pressure until the pumps start moving.

- Place empty containers under the material outlet ball valves (S) and at the end of the material hoses. When the pumps are primed and filling the hoses, open the material outlet valves (for 25C861 only).

**NOTE:** For models 25C862 and 25C863, use the pump bleeder valves (U) for steps 4-6.

- Let the material run into the empty containers until you get a steady stream with no air trapped in the line.
- Close the material outlet ball valves.
- If necessary, continue to let the material run from the hoses into the containers until the material is free of test oil.
- Close the air motor slider valve.

## Dispensing Mixed Material

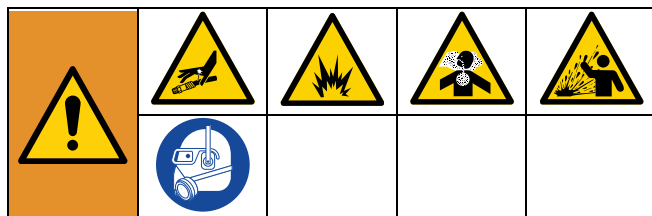

- Install a dispensing device or mixer depending on your requirements. Refer to the instructions included with those devices.
- Open the air motor slider valve (J).
- Open the dispensing device. Adjust the air motor regulator (K) from 20-85 psi (0.14-0.7 MPa, 1.4-7 bar) as needed to obtain the desired flow rate.

## Changing Pails

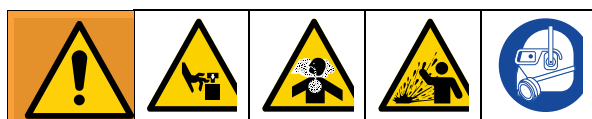

- Close the air motor slider valve (J).
- Using the ram air regulator (M), slowly increase the air pressure and move the ram director valve handle (L) on the air control to the up position

**NOTE:** Use the minimum amount of ram air pressure necessary to push the platen out of the drum.

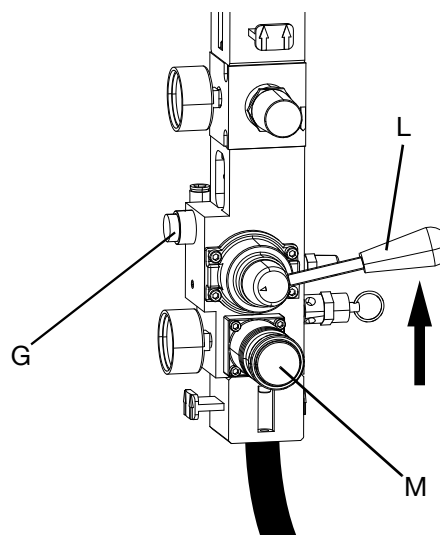

**FIG. 9:** Air Controls for Changing Pails

- Open the pail release valves (P) on both the A and B side.

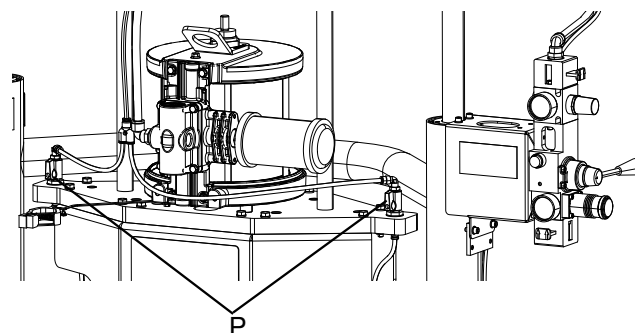

**FIG. 10**

- Press and hold the blow-off button (G) on the air control until the platens (D) are completely out of the pails. See **Figure 9**.

**NOTE:** If one of the platens exits its pail before the other one, close the pail release valve on the one that has exited to allow the other platen to exit its pail.

- Once the platens are out of the pails, close both pail release valves. Raise the ram until you have enough room to remove the pails.
- Inspect the platen and, if necessary, remove any remaining material or material build-up.
- Place new pails on the ram base and follow the steps in **Startup** on page 11.

## Shutdown



1. Move the ram director valve handle (L) to the down position.
2. Follow the **Pressure Relief Procedure**.
3. Follow the pump shutdown instruction as described in the pump manuals referenced in **Related Manuals** on page 3.
8. Open the pump bleeder valves (U), having waste containers ready to catch drainage. Leave the valves open until you are ready to dispense again.
9. If you suspect that the dispensing device tip or hose is clogged or that pressure has not been fully relieved after following the steps above, very slowly loosen the tip guard retaining nut or hose and coupling to relieve pressure gradually; then loosen completely. Clear the hose or tip obstruction.

## Pressure Relief Procedure

 Follow the **Pressure Relief Procedure** whenever you see this symbol.

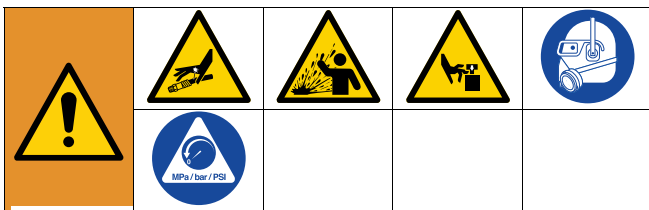

This equipment stays pressurized until pressure is manually relieved. To help prevent serious injury from pressurized fluid, such as skin injection, splashing fluid, and moving parts, follow the **Pressure Relief Procedure** when you stop dispensing and before cleaning, checking, or servicing the equipment.

1. Engage the trigger lock on the dispensing device.
2. Close the air motor slider valve (J) and then close the main air slider valve (N).
3. Move the ram director valve handle (L) to the down position. The ram will slowly drop.
4. Jog the handle up and down to bleed air from the ram cylinders.
5. Disengage the trigger lock.
6. Hold a metal part of the dispensing device firmly to a grounded metal pail. Trigger the device to relieve pressure.
7. Engage the trigger lock.

# Maintenance

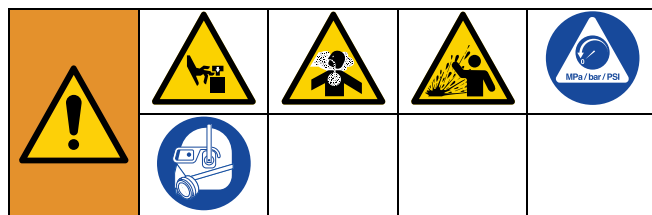

Make sure the displacement pump wet cups (T) remain 2/3 full with Graco Throat Seal Liquid (TSL).

Once a week, check the throat seals on the pumps and tighten them as needed. See *Check-Mate® Pump Packages Instructions - Parts* manual 312376 for more information.

Where applicable, refer to the specific component manual for more detailed information about maintenance. See **Related Manuals** on page 3.

## Platen Maintenance

If a platen (D) does not come out of the pail easily when the pump is being raised, the air assist tube or check valve may be plugged. A plugged valve prevents air from reaching the underside of the plate to assist in raising it from the pail.

1. Follow the **Pressure Relief Procedure** as described on page 14.
2. Clear the air assist tube in the platen. Clean all parts of the valve and reassemble. See *Supply Systems Repair-Parts* manual 313527 for information about disassembling and reassembling the tube and valve.
3. Remove the bleed stick (E) from the platen. Push the bleed stick through the bleed relieve ports to remove material residue.

# Troubleshooting



Check all possible problems before disassembling the ram, pump, or platen. Follow the **Pressure Relief Procedure** on page 14 before making any repairs or replacing parts. Refer to *Supply Systems Repair-Parts* manual 313527 and *55 Gallon (200 Liter), 16 Gallon (60 Liter), and 5 Gallon (20 Liter) Ram Modules Repair-Parts* manual 334198 for system repair information. Refer to *Check-Mate Pump Packages* manual 312376 for pump troubleshooting. See **Related Manuals** on page 3.

Problem	Cause	Solution
Ram will not raise or lower.	Closed air valve or clogged air line.	Open the air valve; clear the clogged air line.
	Not enough air pressure.	Increase air pressure.
	Worn or damaged piston.	Replace the damaged piston. See <i>55 Gallon, 16 Gallon, and 5 Gallon Ram Modules Repair-Parts</i> manual 334198.
	Ram director valve handle closed or clogged.	Open, clear the valve handle. See <i>Supply Systems Repair-Parts</i> manual 313527.
Ram raises and lowers too fast.	Air pressure is too high.	Decrease the air pressure.
Air leaks around cylinder rod.	Worn rod seal.	Replace the rod seal. See <i>55 Gallon, 16 Gallon, and 5 Gallon Ram Modules Repair-Parts</i> manual 334198.
Material squeezes past ram plate wipers.	Air pressure too high.	Decrease the air pressure.
	Worn or damaged wipers.	Replace the wipers. See <i>Supply Systems Repair-Parts</i> manual 313527.
Pump will not prime properly or pumps air.	Closed air valve or clogged air line.	Open the air valve; clear the clogged air line.
	Not enough air pressure.	Increase air pressure.
	Worn or damaged piston.	Replace the piston. See <i>Check-Mate Pump Packages</i> manual 312376.
	Ram director valve handle closed or clogged.	Open, clear the valve handle. See <i>Supply Systems Repair-Parts</i> manual 313527.
	Ram director valve handle is dirty, worn, or damaged.	Clean and service the valve handle.
Air assist valve will not hold pail down or push plate up.	Closed air valve or clogged air line.	Open, clear the air line. See <i>Supply Systems Repair-Parts</i> manual 313527.
	Not enough air pressure.	Increase the air pressure.
	Valve passage clogged.	Clean the valve passage. See <i>Supply Systems Repair-Parts</i> manual 313527.



# Parts

25C861 shown

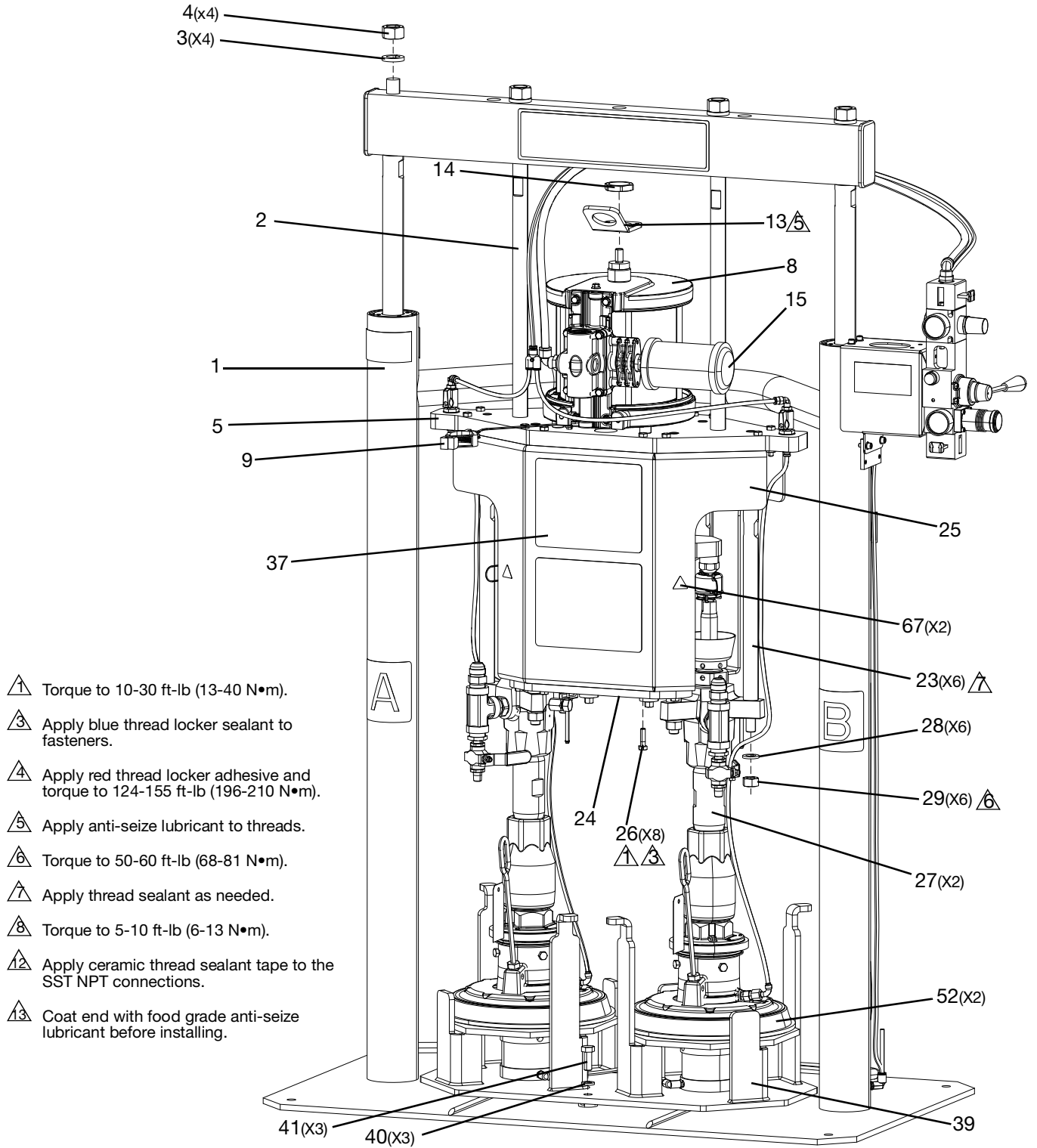
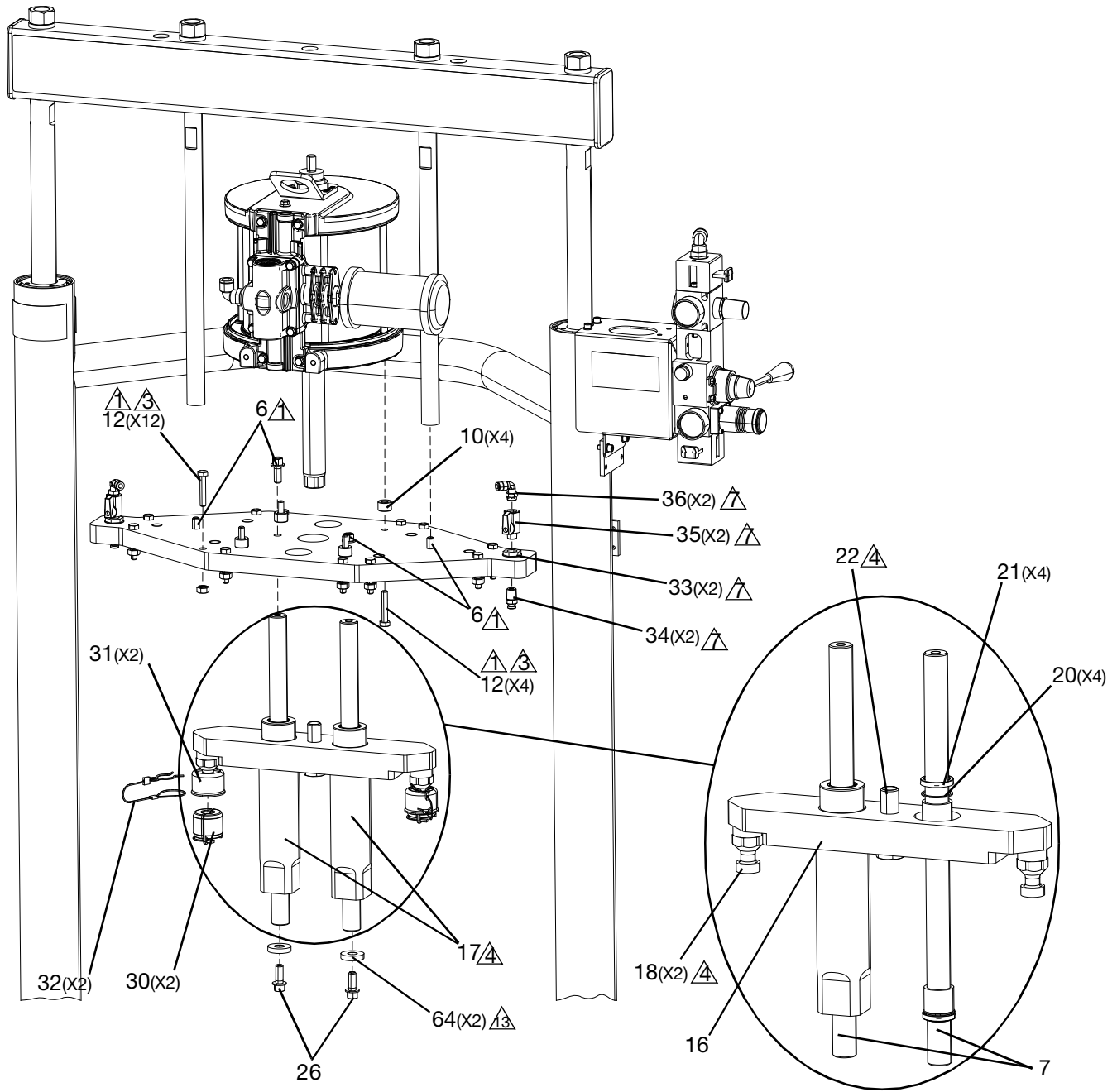
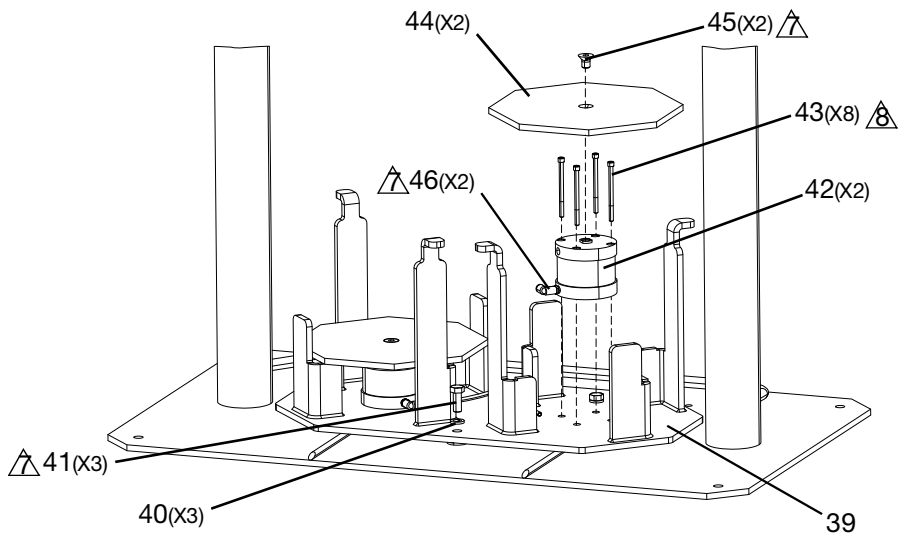

FIG. 11: 1:1 Extruder Front View



**FIG. 12: Inside Shields**



**FIG. 13: Base**

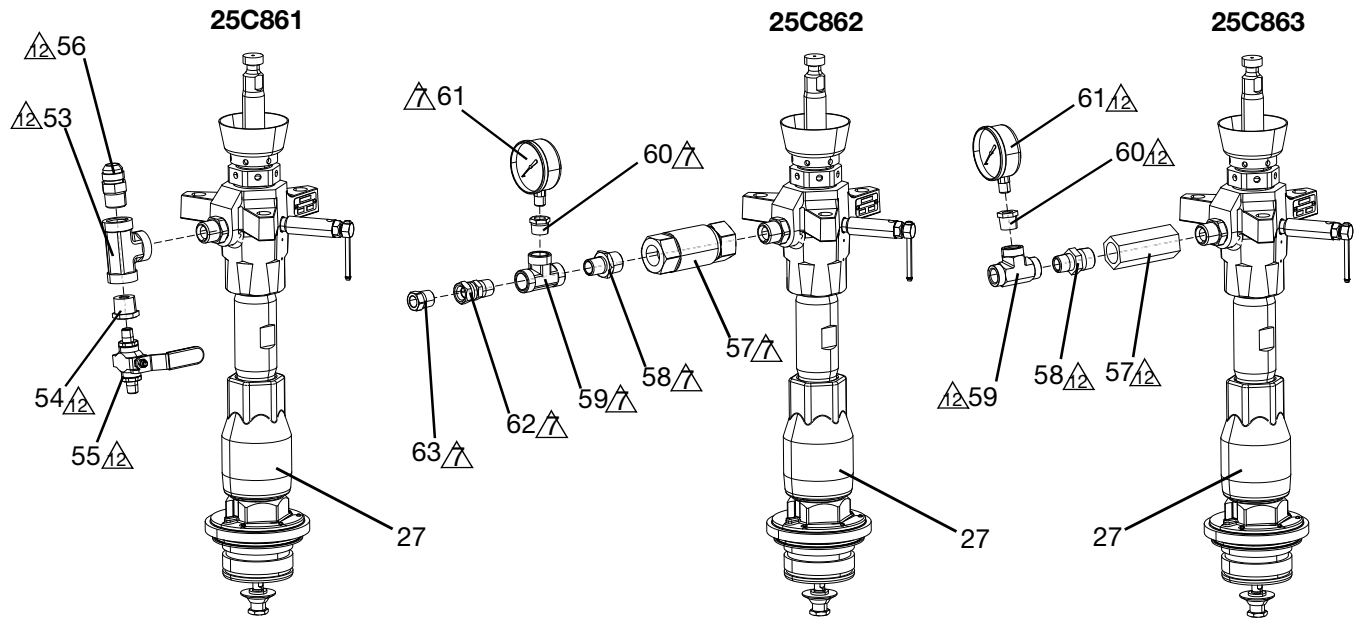

**FIG. 14: Pumps**

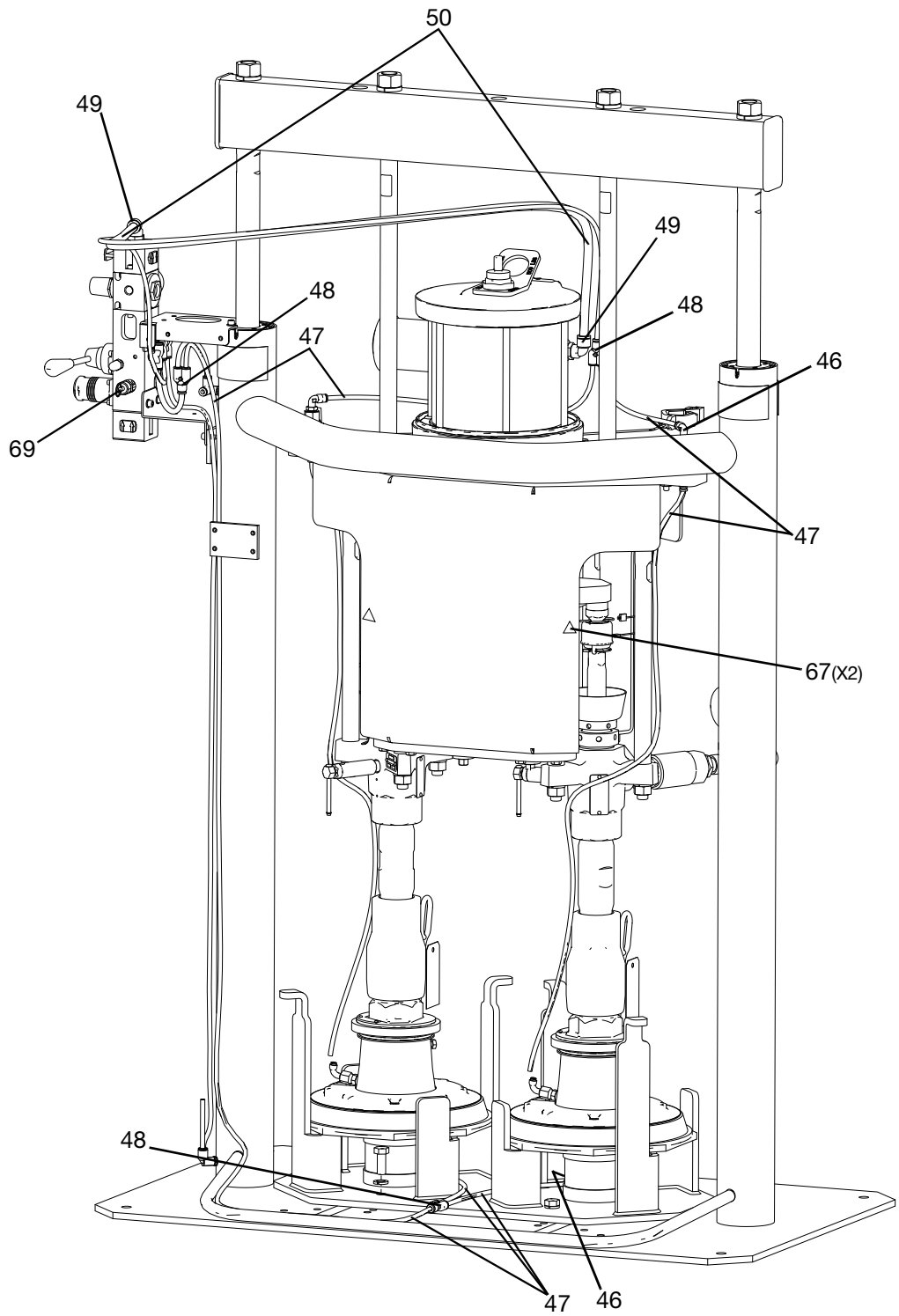

**FIG. 15: Rear View**

Ref	Part	Description	Quantity		
			25C861	25C862	25C863
1	25C899	RAM, dp, 0v, extruder, silver		1	1
	25C900	RAM, dp, 0v, extruder, white	1		
2	17E142	ROD, tie, platen, upper, 55/5	2	2	2
3	101533	WASHER, spring lock	4	4	4
4	101535	NUT, full hex	4	4	4
5	17S528	PLATE, tie, extruder	1	1	1
6	127048	SCREW, mach, hex, flange, m10 x 1.5 x 2	4	4	4
7	17S898†	SHAFT, bearing	2	2	2
8	24R015	MOTOR, assy, air, 7.5 in., blue	1	1	1
9	238909	WIRE, grounding assembly	1	1	1
10	17S572	SPACER, 3/4 x 1/2, aluminum	4	4	4
12	110036	BOLT	16	16	16
13	15J993	RING, lift, plate	1	1	1
14	188784	NUT, jam, hex	1	1	1
15	102656	MUFFLER,	1	1	1
16	17S925	YOKE, 1:1 extruder	1	1	1
17	17S891	SLEEVE, bearing	2	2	2
18	15H392	ROD, adapter xtreme	2	2	2
20	15M818†	RING, retaining	4	4	4
21	16C897†	SEAL, rod, h-wiper, 1.000 id	4	4	4
22	130179	SCREW, hex hd, 3/4-16 x 2.5, cs	1	1	1
23	257360	ROD, tie, nxt to cm lower	6	6	6
24	17S899	PLATE, locator	1	1	1
25	17S544	SHIELD, yoke, white	2		
	17S545	SHIELD, yoke, silver		2	2
26	130276	SCREW, m8 x 1.25 x 30, hhcs	8	8	8
27	L100SS	LOWER, ss100 severe duty, sst	2		2
	L100CS	LOWER, cm100 severe duty		2	
28	108098	WASHER, lock, spring	6	6	6
29	106166	NUT, mach, hex	6	6	6
30	244819	COUPLING, assembly, 145-290 xtreme	2	2	2
31	197340	COVER, coupler	2	2	2
32	244820	CLIP, hairpin (w/ lanyard)	2	2	2
33	104641	FITTING, bulkhead	2	2	2
34	116658	FITTING, tube, male (1/4 npt)	2	2	2
35	15B565	VALVE, ball	2	2	2
36	114109	FITTING, elbow, male, swivel	2	2	2
37	16D136▲	LABEL, safety, warning, multiple	1	1	1
39	25C954	FRAME, pail locator, silver		1	1
	25C955	FRAME, pail locator, white	1		
40	100018	WASHER, lock, spring	3	3	3

Parts

41	109012	BOLT, hex hd.	3	3	3
42	512004	CYLINDER, air/2 in. stroke	2	2	2
43	113194	SCREW, cap, socket hd	8	8	8
44	623533	PLATE, pail/ram	2	2	2
45	512171	SCREW, machine, socket hd	2	2	2
46	128863	FITTING, elbow	2	2	2
47	C12509‡	TUBE, nylon, rnd	26 ft	26 ft	26 ft
48	129574	FITTING, ptc, union y, 1/4 t	3	3	3
49	15V204	FITTING, elbow, 1/2 npt x 1/2 tube	2	2	2
50	061513‡	TUBE, nylon, 1/2 od x 3/8 id	5.5 ft	5.5 ft	5.5 ft
51	125871*‡	TIE, cable, 7.50 inch	21	21	21
	25A206	PLATE, single, sst, nit, fda approved	2		
52	257727	PLATE, 20 l, single wiper, nitrile		2	
	257729	PLATE, 20 l, single wiper, ptfe			2
53	113833	TEE, pipe, female	2		
54	15M861	FITTING, reducer, pipe, 3/4 x 1/4 sst	2		
55	239018	VALVE, ball, sst	2		
56	15M863	FITTING, connector, male	2		
	16T481	VALVE, check		2	
57	C59546	VALVE, check, 3/4 npt, ss, 5000 psi			2
	157191	FITTING, adapter (1/2 npt x 3/4 npt)		2	
58	16R883	FITTING, nipple, reducing, 3/4 x 1/2			2
	103475	FITTING, tee, pipe		2	
59	502570	FITTING, tee, 1/2 npt			2
	100206	BUSHING, pipe		2	
60	122767	BUSHING, 1/2 x 1/4 npt, mf, ss, 6k, 316			2
61	102814	GAUGE, press, fluid		2	2
62	156684	FITTING, union, adapter		2	
63	158212	BUSHING,		2	
64	164416	WASHER, flat	2	2	2
67	15H108▲	LABEL, safety, warning, pinch	4	4	4
69	116643	VALVE, Safety, relief, air	1	1	1
90	112887*	TOOL, wrench, spanner	1	1	1
91	206995*	FLUID, tsl, 1 qt.	1	1	1

\* Not shown.

▲ Replacement Danger and Warning labels, tags, and cards are available at no cost.

‡ Parts are available in kit 25D108.

‡ Parts are available in kit 25D107.

# Dimensions

25C861 Shown

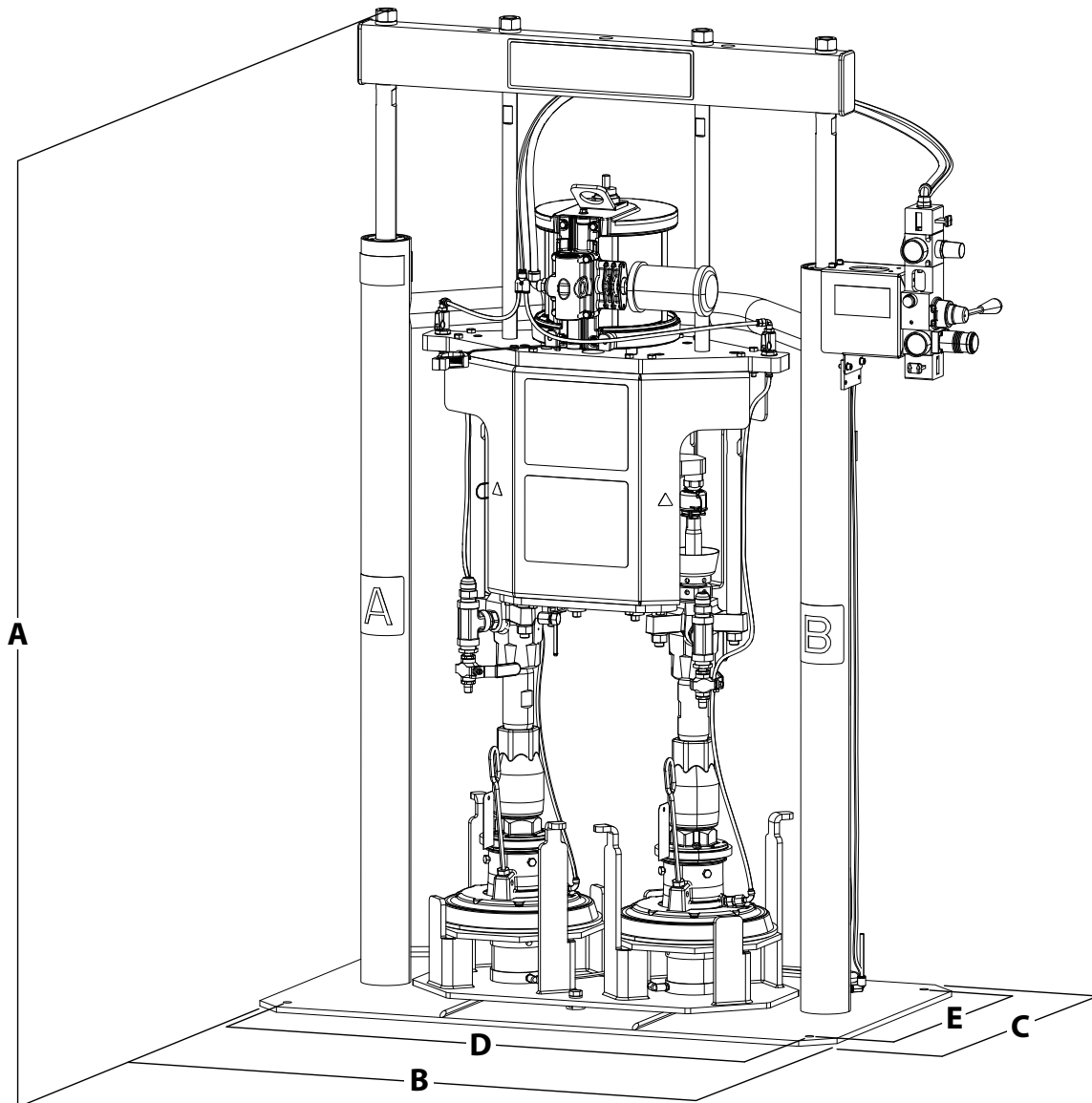

**FIG. 16: 1:1 Extruder Dimensions**

Dimensions	Inches	Millimeters
<b>A</b> (Height)	68.4	1737
(Height Extended)	103.2	2621
<b>B</b> (Width)	42	1067
<b>C</b> (Depth)	25.2	640
<b>D</b> (Mounting Holes Width)	38	965
<b>E</b> (Mounting Holes Depth)	21	533





# Technical Specifications

<b>1:1 Extruder</b>		
	<b>US</b>	<b>Metric</b>
Maximum output pressure	3000 psi	20.7 MPa, 207 bar
Maximum air motor air working pressure	85 psi	0.59 MPa, 5.9 bar
Maximum ram air working pressure	100 psi	0.7 MPa, 7 bar
Weight	626 lb	284 kg
Maximum operating temperature	Ambient	
Mix ratio by volume	1:1	
Pressure ratio (fluid/air)	36:1	
Air consumption	60 cfm maximum at 85 psi at 30 cycles per minute	
Sound power*	77.2 dB(A)	
Sound pressure**	70.5 dB(A)	
Wetted parts◆	<p><b>25C861:</b> 304, 316, and 17-4PH grades of stainless steel; acetal; chrome; UHMWPE; carbon-filled PTFE; PTFE; FKM; white FDA-compliant nitrile</p> <p><b>25C862:</b> ETD 150, 41L40, and 4140 alloy steel; 304 and 17-4PH grades of stainless steel; acetal; carbon-filled PTFE; carbon steel; ductile iron; electroless nickel, zinc, and chrome plating; high molecular weight polyethylene, FKM, nitrile</p> <p><b>25C863:</b> 304, 316, and 17-4PH grades of stainless steel; acetal; chrome; UHMWPE; carbon-filled PTFE; PTFE; FKM; PTFE-coated nitrile</p>	
<b>Inlet/Outlet Sizes</b>		
Air inlet size	1/2 in. npt (f)	
Model 25C861 fluid outlet	JIC-12 Flare	
Model 25C862 fluid outlet	3/8 in. npt (f)	
Model 25C863 fluid outlet	1/2 in. npt (f)	
<b>Notes</b>		
* Sound power at 70 psi (0.48 MPa, 4.8 bar), 20 cpm. Sound Power measured per ISO-9614-2.		
** Sound pressure tested at 3.28 feet (1 meter) from the equipment.		
◆ Refer to specific component manual for more details.		

## California Proposition 65

### CALIFORNIA RESIDENTS

 **WARNING:** Cancer and reproductive harm – [www.P65warnings.ca.gov](http://www.P65warnings.ca.gov).

# Graco Standard Warranty

Graco warrants all equipment referenced in this document which is manufactured by Graco and bearing its name to be free from defects in material and workmanship on the date of sale to the original purchaser for use. With the exception of any special, extended, or limited warranty published by Graco, Graco will, for a period of twelve months from the date of sale, repair or replace any part of the equipment determined by Graco to be defective. This warranty applies only when the equipment is installed, operated and maintained in accordance with Graco's written recommendations.

This warranty does not cover, and Graco shall not be liable for general wear and tear, or any malfunction, damage or wear caused by faulty installation, misapplication, abrasion, corrosion, inadequate or improper maintenance, negligence, accident, tampering, or substitution of non-Graco component parts. Nor shall Graco be liable for malfunction, damage or wear caused by the incompatibility of Graco equipment with structures, accessories, equipment or materials not supplied by Graco, or the improper design, manufacture, installation, operation or maintenance of structures, accessories, equipment or materials not supplied by Graco.

This warranty is conditioned upon the prepaid return of the equipment claimed to be defective to an authorized Graco distributor for verification of the claimed defect. If the claimed defect is verified, Graco will repair or replace free of charge any defective parts. The equipment will be returned to the original purchaser transportation prepaid. If inspection of the equipment does not disclose any defect in material or workmanship, repairs will be made at a reasonable charge, which charges may include the costs of parts, labor, and transportation.

**THIS WARRANTY IS EXCLUSIVE, AND IS IN LIEU OF ANY OTHER WARRANTIES, EXPRESS OR IMPLIED, INCLUDING BUT NOT LIMITED TO WARRANTY OF MERCHANTABILITY OR WARRANTY OF FITNESS FOR A PARTICULAR PURPOSE.**

Graco's sole obligation and buyer's sole remedy for any breach of warranty shall be as set forth above. The buyer agrees that no other remedy (including, but not limited to, incidental or consequential damages for lost profits, lost sales, injury to person or property, or any other incidental or consequential loss) shall be available. Any action for breach of warranty must be brought within two (2) years of the date of sale.

**GRACO MAKES NO WARRANTY, AND DISCLAIMS ALL IMPLIED WARRANTIES OF MERCHANTABILITY AND FITNESS FOR A PARTICULAR PURPOSE, IN CONNECTION WITH ACCESSORIES, EQUIPMENT, MATERIALS OR COMPONENTS SOLD BUT NOT MANUFACTURED BY GRACO.** These items sold, but not manufactured by Graco (such as electric motors, switches, hose, etc.), are subject to the warranty, if any, of their manufacturer. Graco will provide purchaser with reasonable assistance in making any claim for breach of these warranties.

In no event will Graco be liable for indirect, incidental, special or consequential damages resulting from Graco supplying equipment hereunder, or the furnishing, performance, or use of any products or other goods sold hereto, whether due to a breach of contract, breach of warranty, the negligence of Graco, or otherwise.

## **FOR GRACO CANADA CUSTOMERS**

The Parties acknowledge that they have required that the present document, as well as all documents, notices and legal proceedings entered into, given or instituted pursuant hereto or relating directly or indirectly hereto, be drawn up in English. Les parties reconnaissent avoir convenu que la rédaction du présente document sera en Anglais, ainsi que tous documents, avis et procédures judiciaires exécutés, donnés ou intentés, à la suite de ou en rapport, directement ou indirectement, avec les procédures concernées.

# Graco Information

## Sealant and Adhesive Dispensing Equipment

For the latest information about Graco products, visit [www.graco.com](http://www.graco.com).

For patent information, see [www.graco.com/patents](http://www.graco.com/patents).

**TO PLACE AN ORDER**, contact your Graco distributor, go to [www.graco.com](http://www.graco.com), or call to identify the nearest distributor.

**If calling from the USA:** 1-800-746-1334

**If calling from outside the USA:** 0-1-330-966-3000

*All written and visual data contained in this document reflects the latest product information available at the time of publication. Graco reserves the right to make changes at any time without notice.*

Original instructions. This manual contains English. MM 3A5224

**Graco Headquarters:** Minneapolis

**International Offices:** Belgium, China, Japan, Korea

**GRACO INC. AND SUBSIDIARIES • P.O. BOX 1441 • MINNEAPOLIS MN 55440-1441 • USA**  
**Copyright 2016, Graco Inc. All Graco manufacturing locations are registered to ISO 9001.**

[www.graco.com](http://www.graco.com)  
Revision D, March 2024