

## Active Surge Suppressor

3A6103D  
EN

To reduce fluid surging in a low-pressure fluid system. For operation with compressed air. For professional use only.



### Important Safety Instructions

Read all warnings and instructions in this manual before using this equipment. **Save these instructions.**

*See page 2 for model information, including maximum working pressure and approvals.*

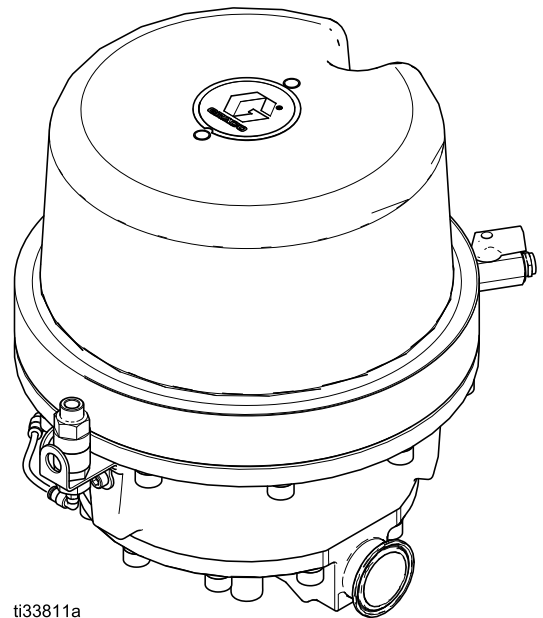

ti33811a

# Contents

Models.....	2	Charge the Suppressor .....	11
Warnings .....	3	Troubleshooting.....	12
Installation.....	6	Repair/Service.....	13
General Information .....	6	Install the Diaphragm Repair Kit.....	13
Grounding .....	6	Parts.....	15
Hose Grounding Continuity.....	7	Kits .....	17
Flushing Safety.....	7	Direct Mount Kit, 18A983.....	17
Mounting .....	9	Floor/Wall Mount Surge Suppressor,	
Breather Valve Mounting		18A984 .....	18
Requirements.....	9	Floor Stand Adapter Kit, 18A985.....	19
Breather Valves .....	9	Dimensions and Mounting Hole Layout .....	20
Connecting the Air Line .....	10	Technical Specifications.....	21
Fluid Inlet and Outlet Ports .....	10	California Proposition 65 .....	21
Fluid Lines and Accessories .....	10		
Operation.....	11		
Pressure Relief Procedure.....	11		

# Models

Part No.	Description	Maximum Fluid Working Pressure
17W739	SST 1.5 in sanitary tri-clamp	300 psi (2.1 MPa, 21 bar)







Approvals:



II 2 G Ex h IIB T6 Gb

# Warnings

The following warnings are for the setup, use, grounding, maintenance, and repair of this equipment. The exclamation point symbol alerts you to a general warning and the hazard symbols refer to procedure-specific risks. When these symbols appear in the body of this manual, refer back to these Warnings. Product-specific hazard symbols and warnings not covered in this section may appear throughout the body of this manual where applicable.

 <h1 style="margin: 0;">WARNING</h1>	
   	<p><b>FIRE AND EXPLOSION HAZARD</b></p> <p>Flammable fumes, such as solvent and paint fumes, in the work area can ignite or explode. Paint or solvent flowing through the equipment can cause static sparking. To help prevent fire and explosion:</p> <ul style="list-style-type: none"> <li>• Use equipment only in a well-ventilated area.</li> <li>• Eliminate all ignition sources such as pilot lights, cigarettes, portable electric lamps, and plastic drop cloths (potential static sparking).</li> <li>• Ground all equipment in the work area. See <b>Grounding</b> instructions.</li> <li>• Never spray or flush solvent at high pressure.</li> <li>• Keep the work area free of debris, including solvent, rags, and gasoline.</li> <li>• Do not plug or unplug power cords, or turn power or light switches on or off when flammable fumes are present.</li> <li>• Use only grounded hoses.</li> <li>• Hold the gun firmly to the side of a grounded pail when triggering into a pail. Do not use pail liners unless they are antistatic or conductive.</li> <li>• <b>Stop operation immediately</b> if static sparking occurs or you feel a shock. Do not use equipment until you identify and correct the problem.</li> <li>• Keep a working fire extinguisher in the work area.</li> </ul>
  	<p><b>PRESSURIZED EQUIPMENT HAZARD</b></p> <p>Fluid from the equipment, leaks, or ruptured components can splash in the eyes or on skin and cause serious injury.</p> <ul style="list-style-type: none"> <li>• Follow the <b>Pressure Relief Procedure</b> when you stop spraying/dispensing and before cleaning, checking, or servicing equipment.</li> <li>• Tighten all fluid connections before operating the equipment.</li> <li>• Check hoses, tubes, and couplings daily. Replace worn or damaged parts immediately.</li> </ul>

# WARNING



## EQUIPMENT MISUSE HAZARD

Misuse can cause death or serious injury.



- Do not operate the unit when fatigued or under the influence of drugs or alcohol.
- Do not exceed the maximum working pressure or temperature rating of the lowest rated system component. See **Technical Specifications** in all equipment manuals.
- Use fluids and solvents that are compatible with equipment wetted parts. See **Technical Specifications** in all equipment manuals. Read fluid and solvent manufacturer's warnings. For complete information about your material, request a Safety Data Sheet (SDS) from your distributor or retailer.
- Do not leave the work area while equipment is energized or under pressure.
- Turn off all equipment and follow the **Pressure Relief Procedure** when equipment is not in use.
- Check equipment daily. Repair or replace worn or damaged parts immediately with genuine manufacturer's replacement parts only.
- Do not alter or modify equipment. Alterations or modifications may void agency approvals and create safety hazards.
- Make sure all equipment is rated and approved for the environment in which you are using it.
- Use equipment only for its intended purpose. Call your distributor for information.
- Route hoses and cables away from traffic areas, sharp edges, moving parts, and hot surfaces.
- Do not kink or over bend hoses or use hoses to pull equipment.
- Keep children and animals away from the work area.
- Comply with all applicable safety regulations.
- Do not lift pressurized equipment.



## PRESSURIZED ALUMINUM PARTS HAZARD

Use of fluids that are incompatible with aluminum in pressurized equipment can cause serious chemical reaction and equipment rupture. Failure to follow this warning can result in death, serious injury, or property damage.

- Do not use 1,1,1-trichloroethane, methylene chloride, other halogenated hydrocarbon solvents or fluids containing such solvents.
- Do not use chlorine bleach.
- Many other fluids may contain chemicals that can react with aluminum. Contact your material supplier for compatibility.



# WARNING

**TOXIC FLUID OR FUMES HAZARD**

Toxic fluids or fumes can cause serious injury or death if splashed in the eyes or on skin, inhaled, or swallowed.



- Read the Safety Data Sheet (SDS) to know the specific hazards of the fluids you are using.
- Route exhaust away from work area. If the diaphragm ruptures, fluid may be exhausted into the air.
- Store hazardous fluid in approved containers, and dispose of it according to applicable guidelines.

**PERSONAL PROTECTIVE EQUIPMENT**

Wear appropriate protective equipment when in the work area to help prevent serious injury, including eye injury, hearing loss, inhalation of toxic fumes, and burns. Protective equipment includes but is not limited to:

- Protective eyewear and hearing protection.
- Respirators, protective clothing, and gloves as recommended by the fluid and solvent manufacturer.

# Installation

## General Information

- The [Typical Installation](#) is only a guide for installing system components and accessories. It is not an actual system design. Contact your Graco distributor for assistance in designing a system to suit your particular needs.
- Always use Genuine Graco Parts and Accessories, available from your Graco distributor. If you supply your own accessories, be sure they are adequately sized and pressure-rated for your system.
- Reference numbers and letters in parentheses refer to the reference numbers in the figures and in the parts lists.

## Grounding

				
<p>The equipment must be grounded to reduce the risk of static sparking. Static sparking can cause fumes to ignite or explode. Grounding provides an escape wire for the electric current.</p>				

Ground the suppressor and the rest of your system.

Ground the suppressor and all other spray equipment used or located in the spray area. The following are minimum requirements for grounding a basic spray system. Your system may include other equipment or objects which must also be grounded. Always check your local electrical code for detailed grounding instructions. Be sure your system is connected to a true earth ground.

- **Pump:** Use a ground wire and clamp as described in your separate pump instruction manual.
- **Air compressors and hydraulic power supplies:** Follow the manufacturer's recommendations.
- **Air and fluid lines:** Use only grounded hoses with a maximum of 150 m (500 ft) combined hose length to ensure grounding continuity. See [Hose Grounding Continuity, page 7](#).

- **Surge suppressor:** Use a ground wire and clamp. Loosen the grounding screw (19). Insert one end of a 12 ga (1.5 mm<sup>2</sup>) minimum ground wire (M) behind the grounding screw and tighten the screw securely. Connect the clamp end of the ground wire to a true earth ground. For a ground wire and clamp, order Part No. 222011.
- **Spray gun:** Obtain grounding through a connection to a properly grounded fluid hose and pump.
- **Object being sprayed:** Follow your local code.
- **Fluid supply container:** Follow your local code.
- **All fluid pails used when flushing:** Follow your local code. Use only conductive metal pails placed on a grounded surface. Do not place the pail on a nonconductive surface, such as paper or cardboard, which interrupts the grounding continuity.
- To maintain grounding continuity when flushing or relieving pressure, always hold a metal part of the gun firmly to the side of a grounded metal pail, then trigger the gun.

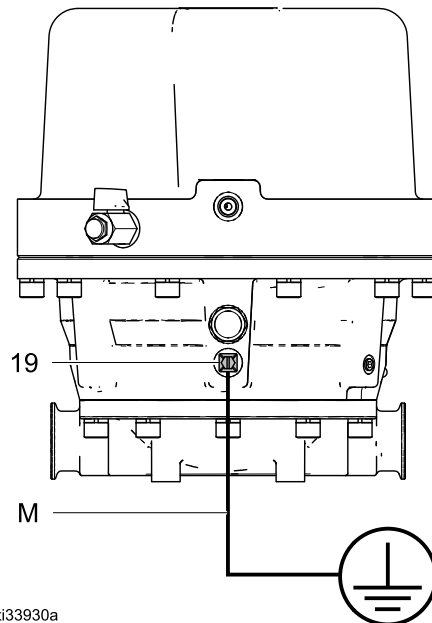

Figure 1 Ground the Suppressor

## **Hose Grounding Continuity**

Proper hose grounding continuity is essential to maintaining a grounded spray system. Check the electrical resistance of your air and fluid hoses at least once a week. If your hose does not have a tag on it which specifies the maximum electrical resistance, contact the hose supplier or manufacturer for the maximum resistance limits. Use a resistance meter in the appropriate range for your hose to check the resistance. If the resistance exceeds the recommended limits, replace the hose immediately.

## **Flushing Safety**

Before flushing, be sure the entire system and flushing pails are properly grounded. See [Grounding, page 6](#) .

## Typical Installation

The surge suppressor is sold separately from all accessories. Filters, regulators, fittings, hoses, and so on, are shown here to depict one possible system setup.

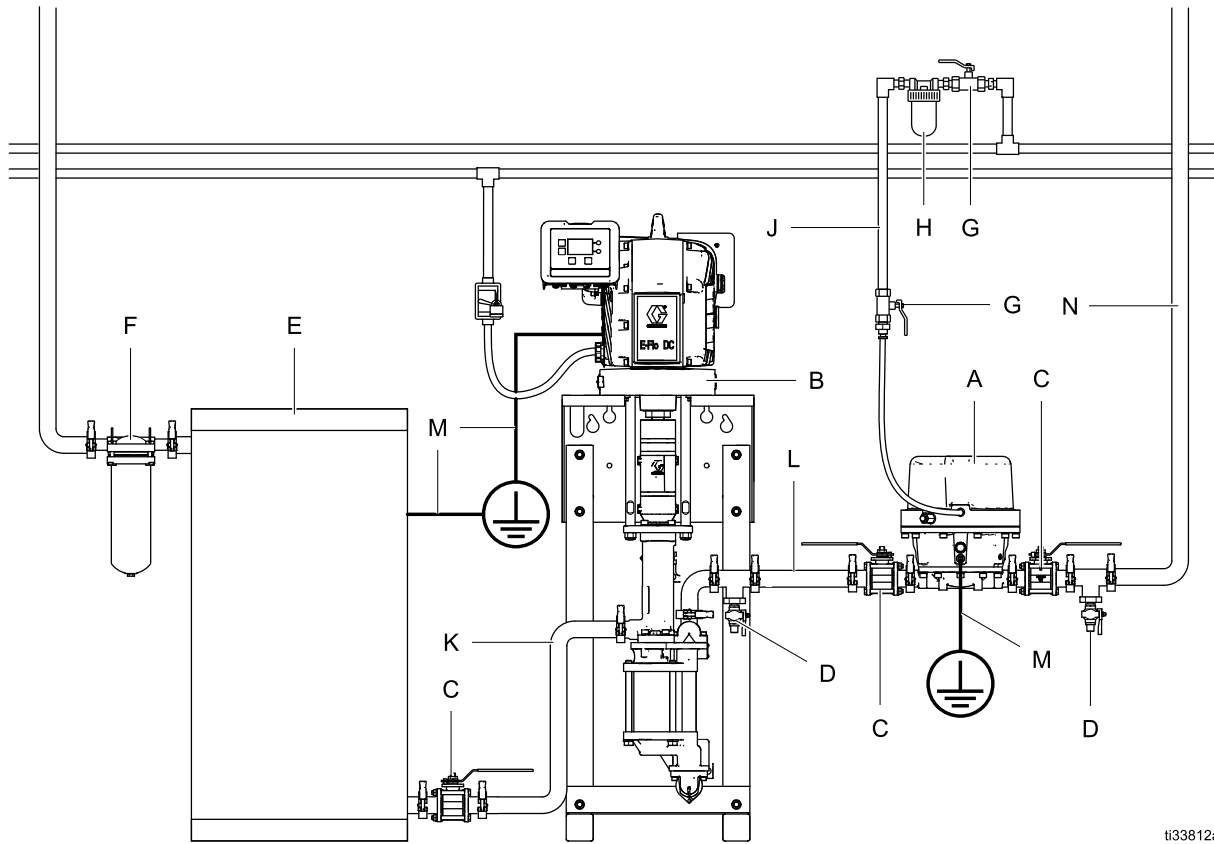

This installation is only a guide for selecting and installing a system. It is not an actual system design. Contact your Graco distributor for assistance in designing a system to suit your needs.

### KEY

- |   |                              |   |                                    |
|---|------------------------------|---|------------------------------------|
| A | Surge suppressor             | H | Air filter                         |
| B | Pump                         | J | Air line to surge suppressor       |
| C | Fluid shutoff valve          | K | Pump inlet fluid line              |
| D | Fluid drain valve*           | L | Pump outlet fluid line             |
| E | Mix tank                     | M | Ground wire                        |
| F | Fluid filter                 | N | Surge suppressor outlet fluid line |
| G | Bleed-type master air valve* |   |                                    |

\* Required for safe operation. Must be purchased separately.



## Mounting

The active surge suppressor must be mounted vertically. For more information, see [Dimensions and Mounting Hole Layout, page 20](#).

Three mounting kits are available:

- [Direct Mount Kit, 18A983, page 17](#)
- [Floor/Wall Mount Surge Suppressor, 18A984, page 18](#)
- [Floor Stand Adapter Kit, 18A985, page 19](#)

## Breather Valve Mounting Requirements

The breather valve must be mounted in a vertical position to function properly. The breather valve mounting bracket allows the repositioning of the valve for the required vertical mounting.

The breather valve system indicates a breach in the diaphragm. If a breach occurs, the working fluid passes through the diaphragm to the back side of the diaphragm. Fluid then flows into the clear tubing and into the breather valve. The breather valve stops the fluid from exiting the suppressor.

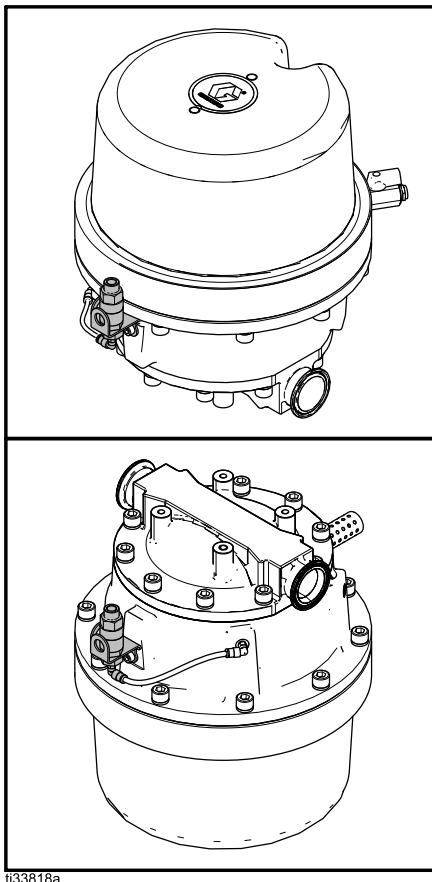

Figure 2 Possible Breather Valve Mounting Positions

## Breather Valves

1. Assemble the breather valve (33b) to the mounting bracket (33a) with the jam nut (33c). Torque to 8–10 ft-lb (11–14 N•m). Thread the air fitting (33d) into the breather valve (33b).

### Note

Before assembling the breather valve system, verify clearances by setting up the breather valves vertically as a test. Mounting brackets have several possible breather valve mounting configurations.

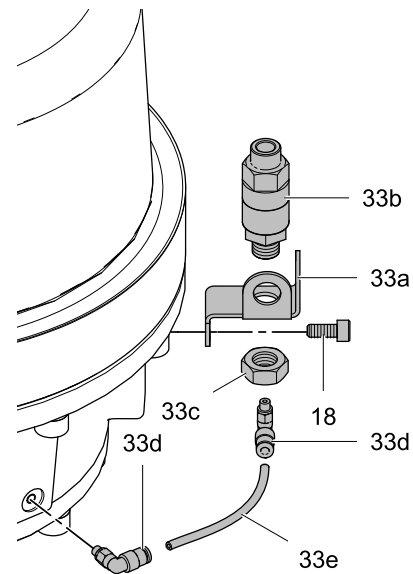

ti33931a

2. Attach the assembly to the air cover (13) using a screw (18).

### Note

Breather valve assemblies must be mounted and installed with the breather valve in the vertical direction for proper operation. See the illustrations in [Figure 2](#) for some possible mounting configurations.

3. Connect the tubing (33e) to the fittings (33d) to complete the breather valve assembly.

## Connecting the Air Line

For optimal performance of the surge suppressor, note the following:

- Size of the inlet and outlet ports:  
Each port is 1.5 inches in diameter.
- Size of the air line:  
Do not use an air line smaller than 1/4 inch NPT.
- Amount of air pressure:
  - The air pressure must be at least 1/3 of the fluid pressure.
  - The air pressure must not exceed 100 psi (.7 MPa, 7 bar).

For example:

- If the fluid pressure is 180 psi (1.2 MPa, 12 bar), use an air pressure from 60–100 psi (.4–.7 MPa, 4–7 bar).
- If the fluid pressure is 220 psi (1.5 MPa, 15 bar), use an air pressure from 73–100 psi (.5–.7 MPa, 5–7 bar).

## Fluid Inlet and Outlet Ports

Either port may be used as the fluid inlet. The direction of fluid flow does not affect the performance. See [Dimensions and Mounting Hole Layout, page 20](#).

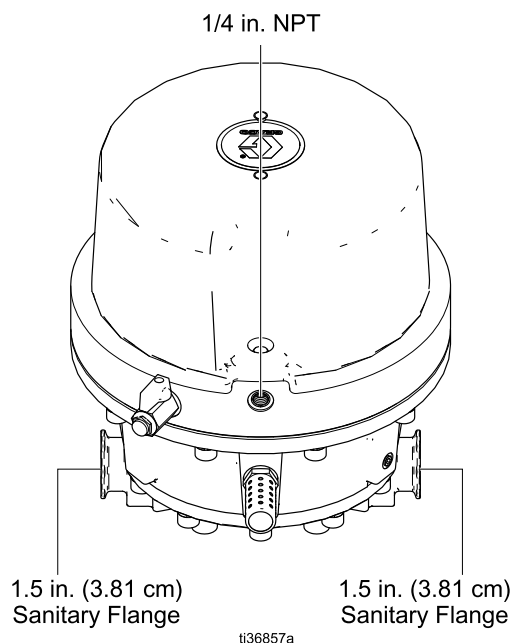

Figure 3 Surge Suppressor Ports

## Fluid Lines and Accessories

Proper line sizing is an important part of the system. Contact your Graco distributor if you need assistance. To obtain proper flow through the system, use the proper size plumbing.

Use a minimum 25 mm (1 in.) diameter flexible hose between the pump and suppressor and a hard or flexible pipe after the suppressor.

<p>A fluid drain valve is required in your system to help reduce the risk of serious injury, including splashing fluid in the eyes or on the skin, or contamination from hazardous fluids when relieving pressure. Opening the fluid drain valve helps relieve pressure in the surge suppressor, pumps, hose, and gun after shutting off the system. Triggering the gun to relieve pressure may not be sufficient.</p>				

1. Install a fluid drain valve (D) near the surge suppressor outlet.
2. Install a fluid shutoff valve (C) before and after the surge suppressor to isolate it when servicing the suppressor.

### Note

When using Direct Mount Kit (18A983), install the fluid shutoff valve (C) after the surge suppressor. ([Direct Mount Kit, 18A983, page 17.](#))

# Operation

## Pressure Relief Procedure



Follow the Pressure Relief Procedure whenever you see this symbol.

<p>This equipment stays pressurized until pressure is manually relieved. To help prevent serious injury from pressurized fluid, such as splashing in the eyes or on skin, follow the <b>Pressure Relief Procedure</b> when you stop pumping and before you clean, check, or service the equipment.</p>				

1. Shut off the power to the pump.
  - In a hydraulic system, close the hydraulic shutoff valves.
  - In an air-powered system, close the pump air regulator and close the bleed-type master air valve (required in your system).
2. Close the fluid shutoff valves from the supply tanks.
3. Hold a metal part of the gun (if used) to a grounded metal pail. Trigger the gun to relieve the pressure.
4. Open the fluid drain valve (required in your system), having a container ready to catch the drainage. Keep hands away from the end of the drain valve when opening it.
5. Leave the drain valve open until you are ready to return to operation.
6. Close the bleed type air valve that is connected to the inlet of the surge suppressor.

7. Before relieving the air pressure in the surge suppressor, ensure that you have relieved the fluid pressure.

Open the surge suppressor air relief valve (39), as shown in the following figure.

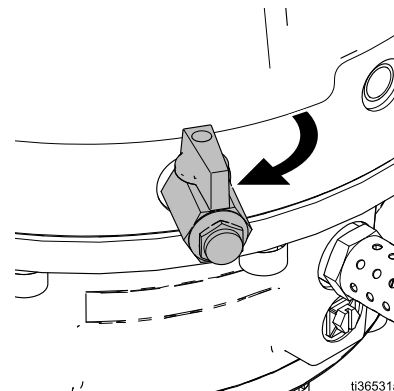
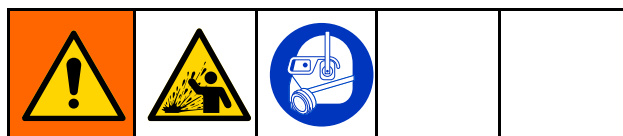

Figure 4 Surge Suppressor Relief Valve

## Charge the Suppressor



1. Open the air valve to the suppressor. The surge suppressor automatically adjusts the air charge pressure for optimal performance.

To work effectively, the air pressure must be at least 1/3 of the fluid pressure.

### Note

The maximum fluid working pressure for the surge suppressor is 300 psi (2.1 MPa, 21 bar). Do not exceed the fluid line pressure or the associated suppressor air pressure.

2. Turn on the pump as described in the pump manual.

# Troubleshooting

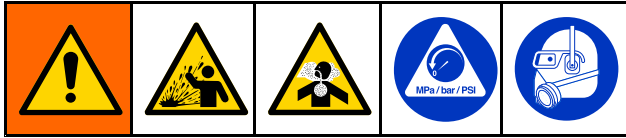

- Follow the [Pressure Relief Procedure, page 11](#) before you check or service the surge suppressor or remove the surge suppressor from the system.
- Check all possible problems and causes before disassembly.

Problem	Cause	Solution
Poor pulsation reduction.	The surge suppressor is undersized for the application.	Reduce the working fluid pressure and/or flow rate.  Install a larger surge suppressor model.
	Extended pump change-over time due to worn or held open check valves.	Repair the piston pump.
	Ruptured diaphragm.	Replace diaphragm.
	Worn piston O-ring.	Replace piston seal.

# Repair/Service

## Install the Diaphragm Repair Kit

The Diaphragm Repair Kit (17X733) is available and can be ordered separately. See the Parts List footnote in [Parts, page 15](#).

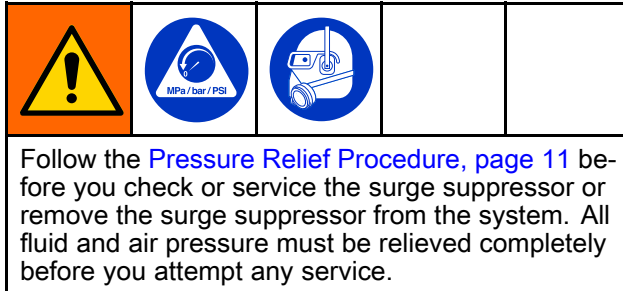

## Disassemble the Surge Suppressor

1. Follow the [Pressure Relief Procedure, page 11](#) to relieve fluid and air pressure.
2. If rebuilding the active surge suppressor diaphragm, replace the breather valves.
  - a. Remove the fluid tube (33e).
  - b. Remove the air connection fitting (33d).
  - c. Remove the nut (33c) on the bottom of the vent to remove the breather valve (33b).
3. Remove any fluid mount plate or bracket that is screwed to the fluid housing (1).
4. Disassemble the air housing.
  - a. Remove the cap screws (22) and lock washers (42).
  - b. Separate the air cover (13) from the piston housing (6). Be careful not to damage the machined flange surfaces or components attached to either housing.
  - c. Remove the o-ring (41).
  - d. Remove the supply air pilot valve (15). Inspect and replace if necessary. Torque to 100-120 in-lbs.
  - e. Use a 10 mm wrench in the retaining screw (12) to loosen the piston assembly (P). Tip the housing to completely remove the piston assembly (P) from the piston housing (6).
5. Remove the o-ring (10) from around the piston (9).
6. Disassemble the fluid housing.
  - a. Remove the cap screws (22).
  - b. Separate the fluid cover (1) from the piston housing (6).
  - c. Remove the diaphragm (2), diaphragm plate (17), and diaphragm washer (3).
  - d. Inspect the shaft U-cup seal (43) and L-cup seal (5). Remove if necessary. The shaft bearings (4) can remain in place. If the bearings are damaged and need to be removed, use a screwdriver or a large punch to push them out from the other side.
 

Be careful not to damage the surface of the piston housing (6).
  - e. Remove the supply air pilot valve (15). Inspect and replace if necessary. Torque to 100-120 in-lbs.

## Reassemble the Surge Suppressor

1. Reassemble the fluid housing.
  - a. Turn the housing (6) upside-down so that the fluid side is up.
  - b. Apply grease to the L-cup seal (5) and insert it into the bottom of the housing (6). Make sure that the seal's o-ring (5a) faces out, toward the diaphragm (2).

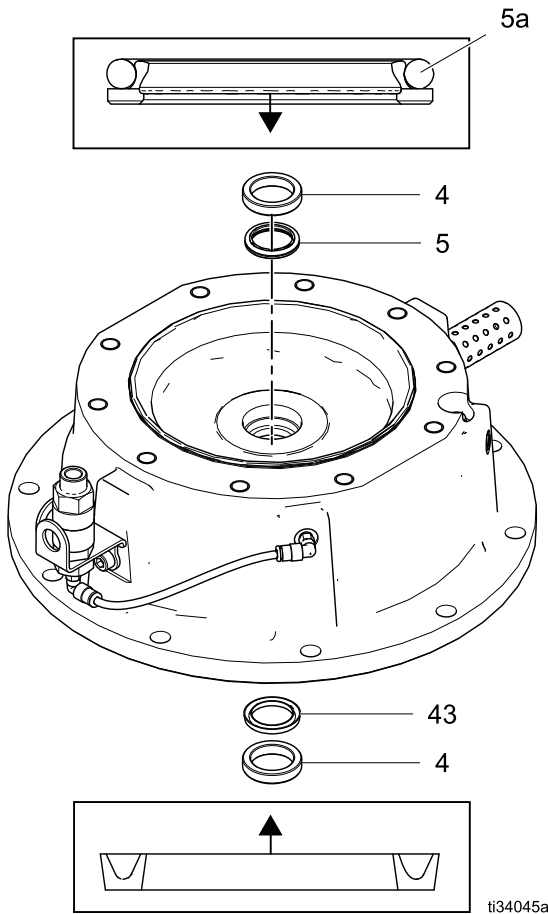





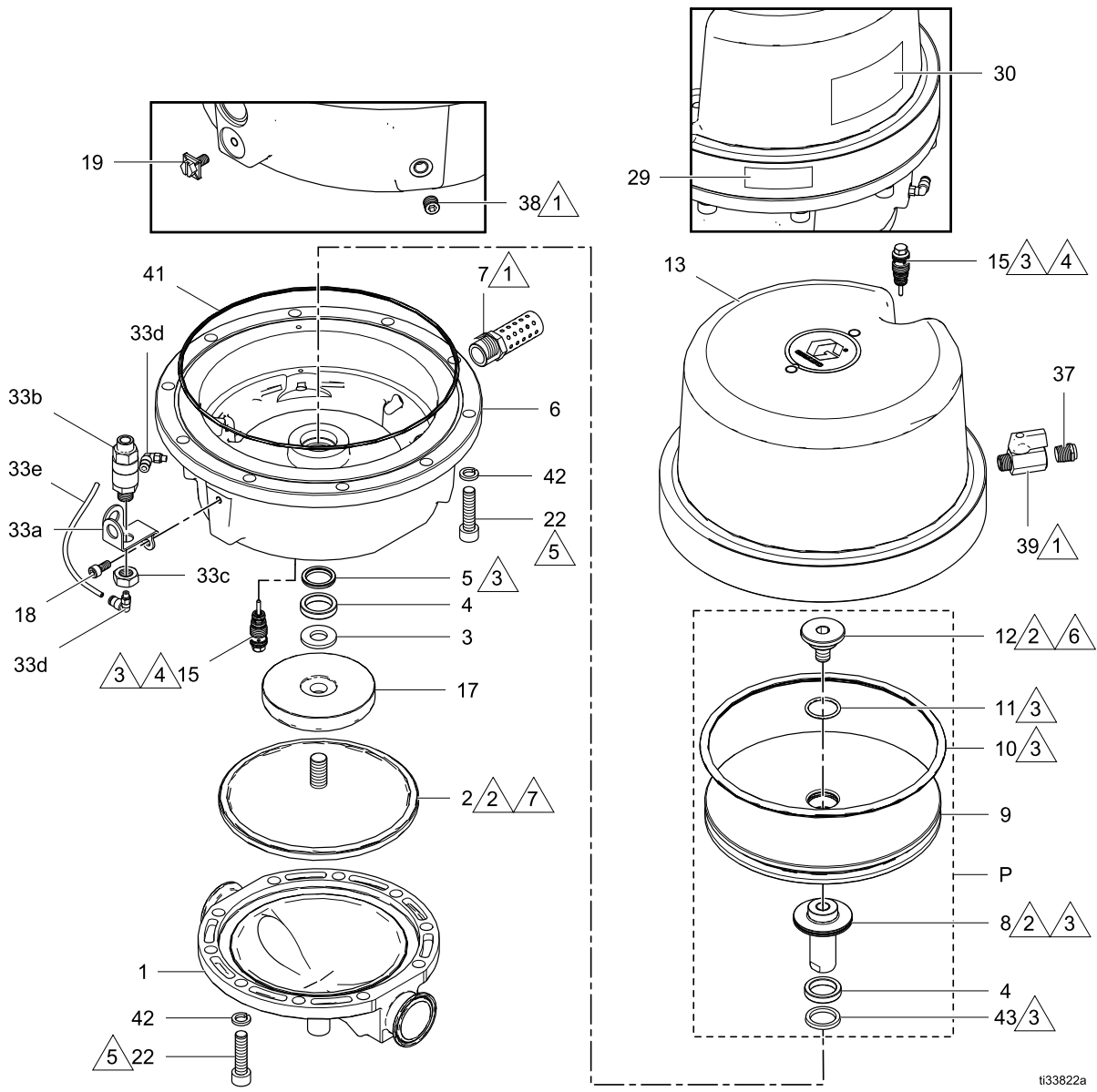

- c. Press one of the bearings (4) into the housing (6) to retain the L-cup seal (5) in the fluid side.
  - d. Turn the housing (6) over so that the air side is up.
  - e. Grease the U-cup seal (43) and install it into the housing (6). Make sure that the open end of the U-cup (43) faces the fluid side as shown in the figure.
  - f. Press one of the bearings (4) into the housing (6) to retain the U-cup seal (43) in the air side.
2. Lubricate and reinstall pilot valve (15) into housing (6). Torque to 100-120 in-lbs.

3. Apply grease to the inner diameter of the housing (6). Insert the piston assembly (P) with the shaft (8) passing through the shaft bearings (4).
4. Apply blue thread locker to the inner threads of the shaft (8).
5. Insert the backer plate (17) and washer (3) over the threads of the diaphragm (2).
6. Thread the diaphragm assembly (2) onto the shaft (8) of the piston assembly (P) and screw to hand-tighten.
7. Install the fluid cover (1). Align the inlet and outlet with the housing (6). Install and tighten the screws (22) in a star pattern to 28-33 ft-lb (38-45 N•m).
8. Use a 10 mm socket driver to torque the diaphragm retainer screw (12) to 75-85 ft-lb (102-115 N•m).
9. Install the o-ring (41) into the housing (6). A small amount of grease will hold the o-ring in place.
10. Align the air cover (13) and housing (6). Install washers (42) and screws (22) to secure the air cover and housing. Torque to 15-20 ft-lb (20-27 N•m) in a star pattern.
11. Replace the breather valve (33b) and fitting (33d). Make sure that the breather valve (33b) is vertical. See [Breather Valves, page 9](#).

# Parts



-  Apply thread sealant.
-  Apply blue thread locker.
-  Apply grease.
-  Torque 100–120 in-lbs (11–14 N•m)
-  Torque 28–33 ft-lb (38–45 N•m)
-  Torque 75–85 ft-lb (102–115 N•m)
-  Torque 15–20 ft-lb (20–27 N•m)

Parts

Ref	Part	Description	Qty
1	17T216	COVER, fluid	1
2*	—	DIAPHRAGM, overmolded	1
3	17B546	WASHER	1
4*	—	BEARING, shaft	2
5*	—	PACKING, L-cup	1
6	17W897	HOUSING, machined body surge suppressor	1
7	15M940	MUFFLER, air valve, medium	2
8	16X308	SHAFT, pump	1
9	16X310	PISTON, helper	1
10*	—	PACKING, o-ring	1
11	107204	PACKING, o-ring	1
12	17T219	SCREW, retaining piston	1
13	17W896	COVER, air	1
15	247391	VALVE, pilot/poppet	2
17	17S448	PLATE, backer	1
19	116343	SCREW, ground	1
22*	—	SCREW, M10 x 30 x 1.5	20

Ref	Part	Description	Qty
30▲	188621	LABEL, warning	1
33a●	—	BRACKET, mounting valve	1
33b●	—	VALVE, breather	1
33c●	—	NUT	1
33d●	—	FITTING, male swivel, air	2
33e●*	—	TUBE, 5/32 OD nylon, pre-cut to 4.5 in.	1
37	121021	MUFFLER, 1/4 NPT	1
38	—	PLUG, pipe	1
39	15B565	VALVE, ball	1
41*	—	O-RING	1
42	16K738	WASHER, split lock, M10	20
43*	—	PACKING, U-cup	1

▲ Replacement Danger and Warning labels, tags, and cards are available at no cost.

● Included in Breather Valve Kit 17X529.

\*Included in Diaphragm Repair Kit 17X733.



# Kits

## Direct Mount Kit, 18A983

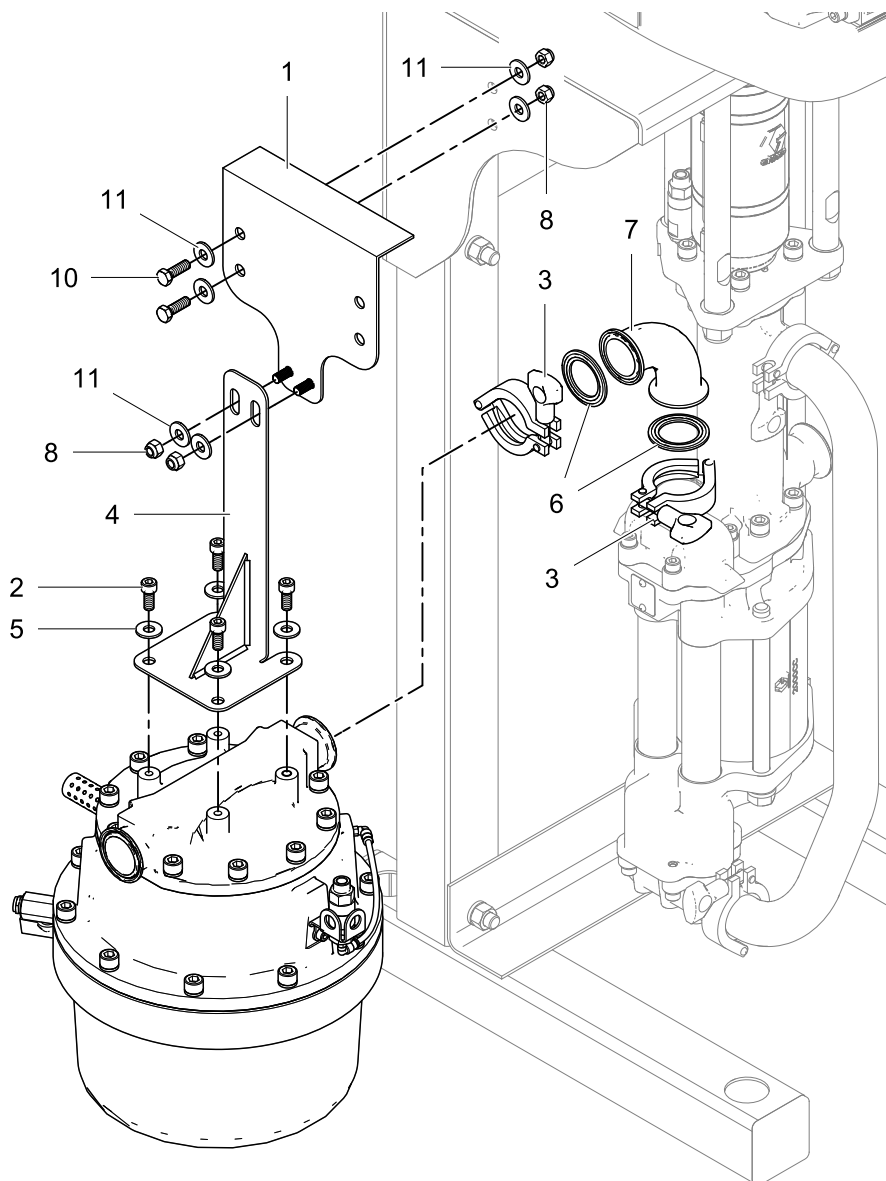

ti36636a

Ref	Part	Description	Qty
1	—	BRACKET, stand, adapter	1
2	—	SCREW, M8x20	4
3	118598	CLAMP, sanitary	2
4	—	BRACKET, tank	1
5	—	WASHER, lock	4

Ref	Part	Description	Qty
6	120351	GASKET, sanitary	2
7	51A796	ELBOW, 90 deg, sanitary	1
8	—	NUT, lock	4
10	—	SCREW, cap	2
11	—	WASHER, flat	6

### Floor/Wall Mount Surge Suppressor, 18A984

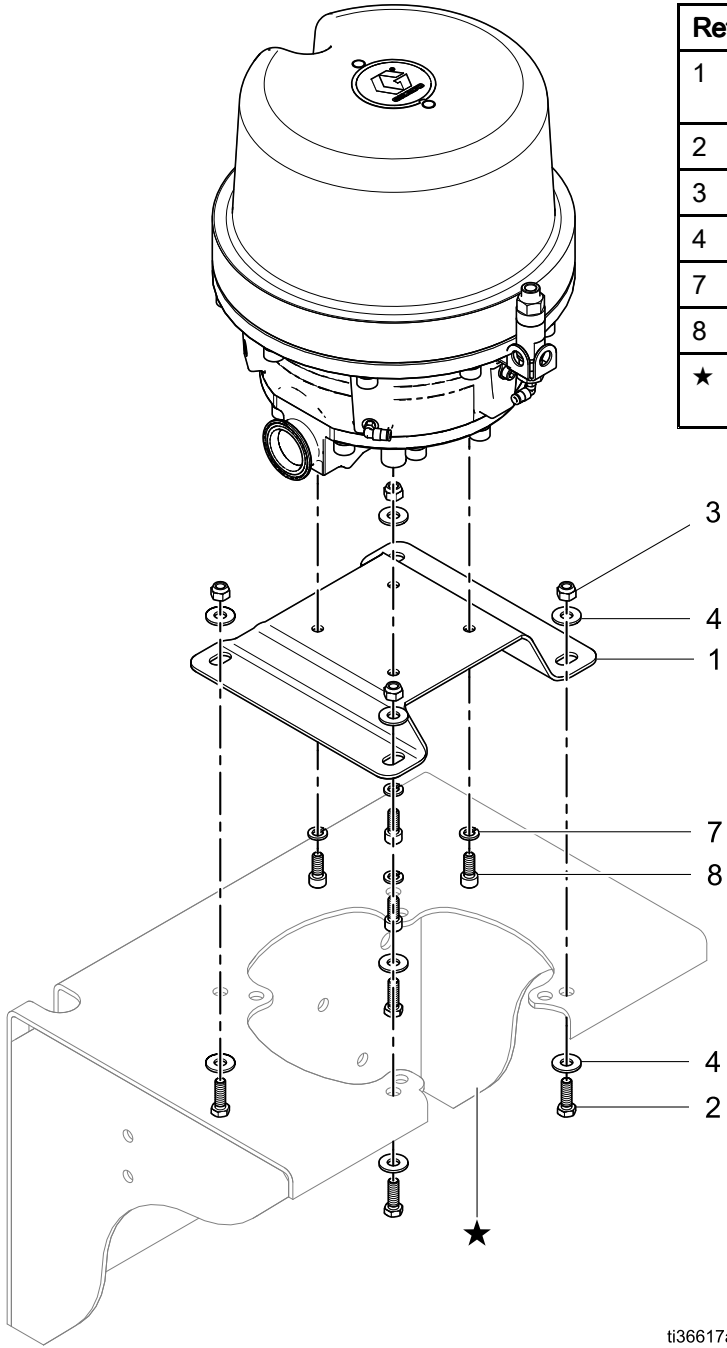

Ref	Part	Description	Qty
1	—	BRACKET, mount surge tank	1
2	—	SCREW, cap	4
3	—	NUT, lock	4
4	—	WASHER, flat	8
7	—	WASHER, lock	4
8	—	SCREW, M8x20	4
★	255143	Wall bracket not included	—

ti36617a

### Floor Stand Adapter Kit, 18A985

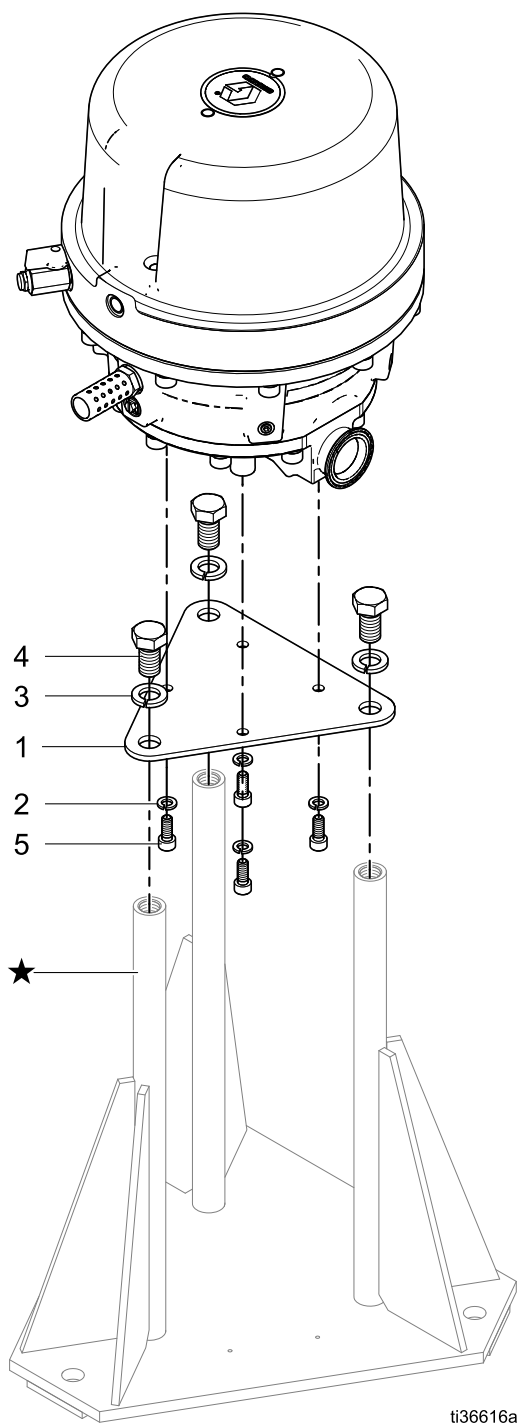

Ref	Part	Description	Qty
1	—	BRACKET, adapter	1
2	—	WASHER, lock spring	4
3	—	WASHER, lock spring	3
4	—	SCREW, M16x30	3
5	—	SCREW, M8x20	4
★	218742	Floor stand not included	—

# Dimensions and Mounting Hole Layout

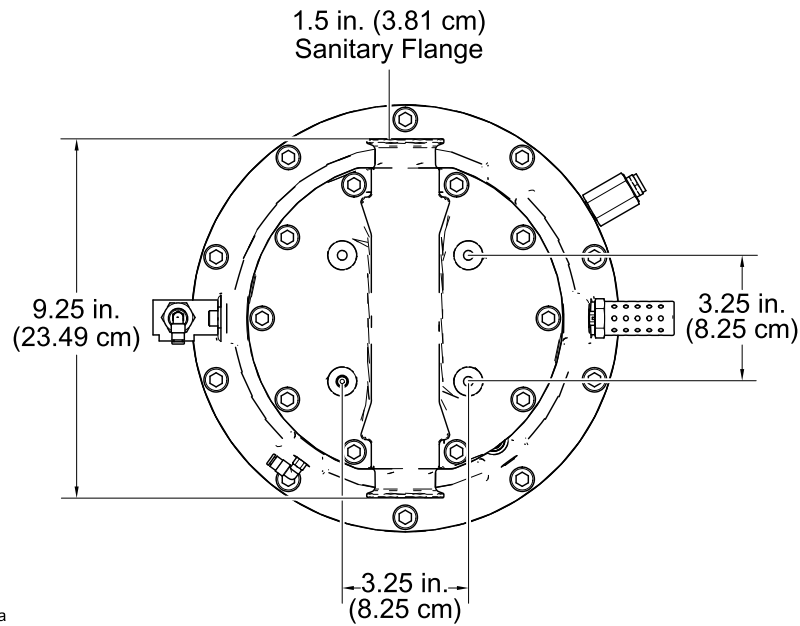
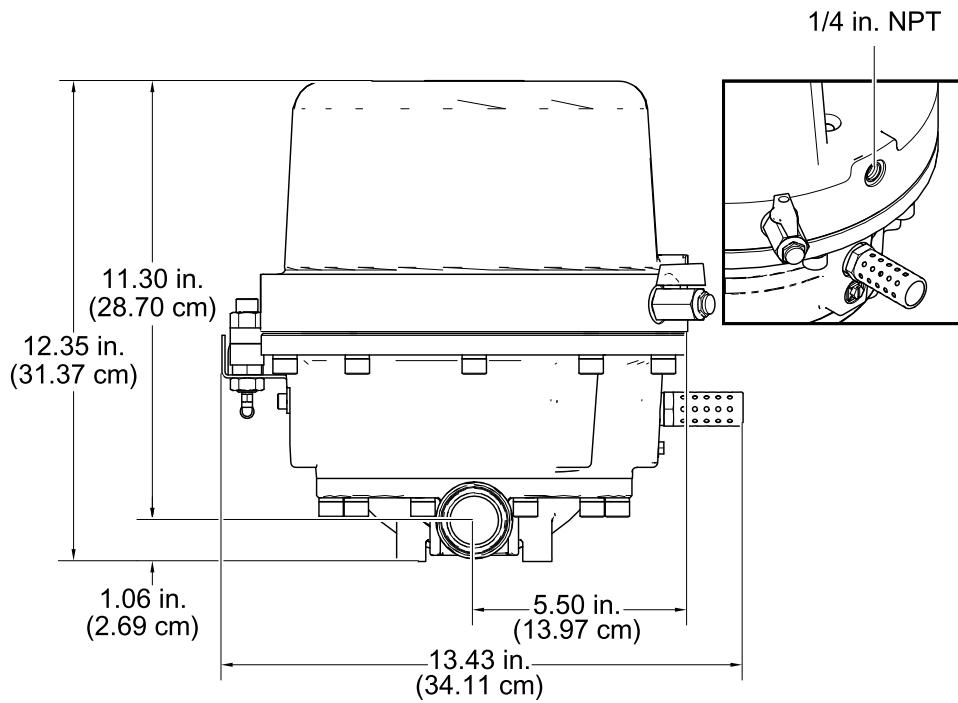

ti33829a

# Technical Specifications

	US	Metric
Maximum fluid inlet pressure	300 psi	2.1 MPa, 21 bar
Maximum fluid regulated pressure	300 psi	2.1 MPa, 21 bar
Maximum air charge pressure	100 psi	0.7 MPa, 7 bar
Maximum flow rate*	10 GPM (Single Pump)	37.8 LPM
	20 GPM (E-Flo DC 2x)	75.7 LPM
Maximum operating temperature	120° F	50° C
Wetted parts	304 stainless steel, PTFE	
Weight	35 lb	15.9 kg

\* Maximum flow rates are recommended maximums for peak performance. Exceeding these values reduces the surge suppressor's ability to dampen pulsation.

## California Proposition 65

### CALIFORNIA RESIDENTS

 **WARNING:** Cancer and reproductive harm — [www.P65warnings.ca.gov](http://www.P65warnings.ca.gov).

# Graco Standard Warranty

Graco warrants all equipment referenced in this document which is manufactured by Graco and bearing its name to be free from defects in material and workmanship on the date of sale to the original purchaser for use. With the exception of any special, extended, or limited warranty published by Graco, Graco will, for a period of twelve months from the date of sale, repair or replace any part of the equipment determined by Graco to be defective. This warranty applies only when the equipment is installed, operated and maintained in accordance with Graco's written recommendations.

This warranty does not cover, and Graco shall not be liable for general wear and tear, or any malfunction, damage or wear caused by faulty installation, misapplication, abrasion, corrosion, inadequate or improper maintenance, negligence, accident, tampering, or substitution of non-Graco component parts. Nor shall Graco be liable for malfunction, damage or wear caused by the incompatibility of Graco equipment with structures, accessories, equipment or materials not supplied by Graco, or the improper design, manufacture, installation, operation or maintenance of structures, accessories, equipment or materials not supplied by Graco.

This warranty is conditioned upon the prepaid return of the equipment claimed to be defective to an authorized Graco distributor for verification of the claimed defect. If the claimed defect is verified, Graco will repair or replace free of charge any defective parts. The equipment will be returned to the original purchaser transportation prepaid. If inspection of the equipment does not disclose any defect in material or workmanship, repairs will be made at a reasonable charge, which charges may include the costs of parts, labor, and transportation.

**THIS WARRANTY IS EXCLUSIVE, AND IS IN LIEU OF ANY OTHER WARRANTIES, EXPRESS OR IMPLIED, INCLUDING BUT NOT LIMITED TO WARRANTY OF MERCHANTABILITY OR WARRANTY OF FITNESS FOR A PARTICULAR PURPOSE.**

Graco's sole obligation and buyer's sole remedy for any breach of warranty shall be as set forth above. The buyer agrees that no other remedy (including, but not limited to, incidental or consequential damages for lost profits, lost sales, injury to person or property, or any other incidental or consequential loss) shall be available. Any action for breach of warranty must be brought within two (2) years of the date of sale.

**GRACO MAKES NO WARRANTY, AND DISCLAIMS ALL IMPLIED WARRANTIES OF MERCHANTABILITY AND FITNESS FOR A PARTICULAR PURPOSE, IN CONNECTION WITH ACCESSORIES, EQUIPMENT, MATERIALS OR COMPONENTS SOLD BUT NOT MANUFACTURED BY GRACO.** These items sold, but not manufactured by Graco (such as electric motors, switches, hose, etc.), are subject to the warranty, if any, of their manufacturer. Graco will provide purchaser with reasonable assistance in making any claim for breach of these warranties.

In no event will Graco be liable for indirect, incidental, special or consequential damages resulting from Graco supplying equipment hereunder, or the furnishing, performance, or use of any products or other goods sold hereto, whether due to a breach of contract, breach of warranty, the negligence of Graco, or otherwise.

## FOR GRACO CANADA CUSTOMERS

The Parties acknowledge that they have required that the present document, as well as all documents, notices and legal proceedings entered into, given or instituted pursuant hereto or relating directly or indirectly hereto, be drawn up in English. Les parties reconnaissent avoir convenu que la rédaction du présente document sera en Anglais, ainsi que tous documents, avis et procédures judiciaires exécutés, donnés ou intentés, à la suite de ou en rapport, directement ou indirectement, avec les procédures concernées.

## Graco Information

For the latest information about Graco products, visit [www.graco.com](http://www.graco.com).  
For patent information, see [www.graco.com/patents](http://www.graco.com/patents).

**To place an order**, contact your Graco Distributor or call to identify the nearest distributor.

**Phone:** 612-623-6921 **or Toll Free:** 1-800-328-0211 **Fax:** 612-378-3505

All written and visual data contained in this document reflects the latest product information available at the time of publication. Graco reserves the right to make changes at any time without notice.

Original Instructions. This manual contains English. MM 3A6103

**Graco Headquarters:** Minneapolis  
**International Offices:** Belgium, China, Japan, Korea

**GRACO INC. AND SUBSIDIARIES • P.O. BOX 1441 • MINNEAPOLIS MN 55440-1441 • USA**  
**Copyright 2019, Graco Inc. All Graco manufacturing locations are registered to ISO 9001.**

[www.graco.com](http://www.graco.com)  
Revision D, June 2021