

Dyna-Star[®] 200:1 and 120:1 Grease Pumps

3A7519E

EN

For dispensing grease in wellhead valve maintenance and wireline applications only. For professional use only.

Dyna-Star 200:1

Model No.

25P785: 400 lb Drum Length

25P784: 120 lb. Drum Length

20,000 psi (137.9 MPa, 1379 bar) Maximum Working Pressure

100 psi (0.69 MPa, 6.89 bar) Maximum Air Pressure

Dyna-Star 120:1

Model No.

26A968: 400 lb Drum Length

26A967: 120 lb. Drum Length

12,000 psi (82.7 MPa, 827 bar) Maximum Working Pressure

100 psi (0.69 MPa, 6.89 bar) Maximum Air Pressure



Important Safety Instructions

Read all warnings and instructions in this manual before using the equipment. Save these instructions.

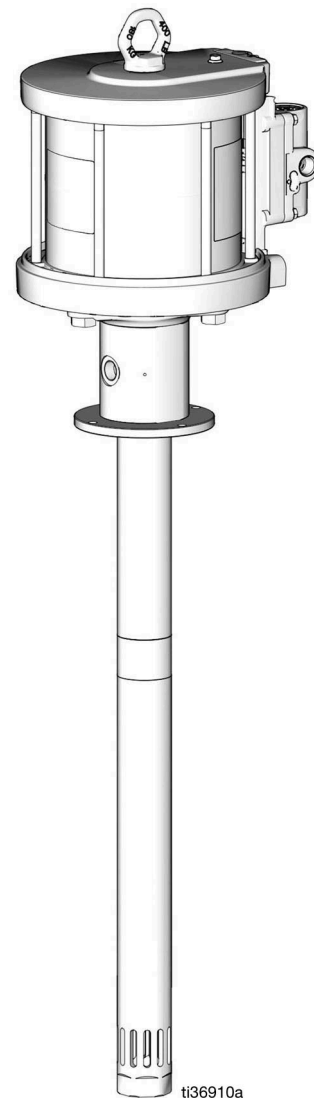

ti36910a

Related Manuals

Manual (English)	Description
3A7718	Dyna-Star [®] Air Motors

Contents

Related Manuals	1
Approvals	2
Warnings	3
Installation	5
Installation Instructions	6
Grounding	7
Operation	8
Pressure Relief Procedure	8
Before Starting Pump	8
Priming and Pump Speed Adjustment	9
Maintenance	10
Suggested tools.....	10
Disassemble.....	10
Reassemble	13
Recycling and Disposal	18
End of Product Life	18
Troubleshooting	19
Parts	20
Accessories	22
Performance Charts	23
Dimensions	24
Mounting Hole Layout	25
Technical Specifications	26
California Proposition 65	27
Graco Standard Warranty	28

Approvals



















II 2 G Ex h IIB T4 Gb

NOTE: Type of Protection "h"
applied is constructional safety
"c".

Warnings

The following warnings are for the setup, use, grounding, maintenance, and repair of this equipment. The exclamation point symbol alerts you to a general warning and the hazard symbols refer to procedure-specific risks. When these symbols appear in the body of this manual or on warning labels, refer back to these Warnings. Product-specific hazard symbols and warnings not covered in this section may appear throughout the body of this manual where applicable.

 <h2 style="margin: 0;">WARNING</h2>	
    	<p>SKIN INJECTION HAZARD</p> <p>High-pressure fluid from dispensing device, hose leaks, or ruptured components will pierce skin. This may look like just a cut, but it is a serious injury that can result in amputation. Get immediate surgical treatment.</p> <ul style="list-style-type: none"> • Do not point dispensing device at anyone or at any part of the body. • Do not put your hand over the fluid outlet. • Do not stop or deflect leaks with your hand, body, glove, or rag. • Follow the Pressure Relief Procedure when you stop dispensing and before cleaning, checking, or servicing equipment. • Tighten all fluid connections before operating the equipment. • Check hoses and couplings daily. Replace worn or damaged parts immediately.
 	<p>FIRE AND EXPLOSION HAZARD</p> <p>When flammable fluids are present in the work area, such as gasoline and windshield wiper fluid, be aware that flammable fumes can ignite or explode. To help prevent fire and explosion:</p> <ul style="list-style-type: none"> • Use equipment only in well-ventilated area. • Eliminate all ignition sources, such as cigarettes and portable electric lamps. • Ground all equipment in the work area. • Keep work area free of debris, including rags and spilled or open containers of solvent and gasoline. • Do not plug or unplug power cords or turn lights on or off when flammable fumes are present. • Use only grounded hoses. • Stop operation immediately if static sparking occurs or you feel a shock. Do not use equipment until you identify and correct the problem. • Keep a working fire extinguisher in the work area.

 <h1 style="margin: 0;">WARNING</h1>	
 	<p>EQUIPMENT MISUSE HAZARD Misuse can cause death or serious injury.</p> <ul style="list-style-type: none"> • Do not operate the unit when fatigued or under the influence of drugs or alcohol. • Do not exceed the maximum working pressure or temperature rating of the lowest rated system component. See Technical Specifications in all equipment manuals. • Use fluids and solvents that are compatible with equipment wetted parts. See Technical Specifications in all equipment manuals. Read fluid and solvent manufacturer’s warnings. For complete information about your material, request Safety Data Sheets (SDSs) from distributor or retailer. • Turn off all equipment and follow the Pressure Relief Procedure when equipment is not in use. • Check equipment daily. Repair or replace worn or damaged parts immediately with genuine manufacturer’s replacement parts only. • Do not alter or modify equipment. Alterations or modifications may void agency approvals and create safety hazards. • Make sure all equipment is rated and approved for the environment in which you are using it. • Use equipment only for its intended purpose. Call your distributor for information. • Route hoses and cables away from traffic areas, sharp edges, moving parts, and hot surfaces. • Do not kink or over bend hoses or use hoses to pull equipment. • Keep children and animals away from work area. • Comply with all applicable safety regulations.
 	<p>MOVING PARTS HAZARD Moving parts can pinch, cut or amputate fingers and other body parts.</p> <ul style="list-style-type: none"> • Keep clear of moving parts. • Do not operate equipment with protective guards or covers removed. • Equipment can start without warning. Before checking, moving, or servicing equipment, follow the Pressure Relief Procedure and disconnect all power sources.
	<p>TOXIC FLUID OR FUMES HAZARD Toxic fluids or fumes can cause serious injury or death if splashed in the eyes or on skin, inhaled, or swallowed.</p> <ul style="list-style-type: none"> • Read Safety Data Sheets (SDSs) to know the specific hazards of the fluids you are using. • Store hazardous fluid in approved containers, and dispose of it according to applicable guidelines.
	<p>BURN HAZARD Equipment surfaces and fluid that is heated can become very hot during operation. To avoid burns:</p> <ul style="list-style-type: none"> • Do not touch hot fluid or equipment.
	<p>PERSONAL PROTECTIVE EQUIPMENT Wear appropriate protective equipment when in the work area to help prevent serious injury, including eye injury, hearing loss, inhalation of toxic fumes, and burns. Protective equipment includes but is not limited to:</p> <ul style="list-style-type: none"> • Protective eyewear, and hearing protection. • Respirators, protective clothing, and gloves as recommended by the fluid and solvent manufacturer.

Installation



Typical Installation

Pump Installation on Drum

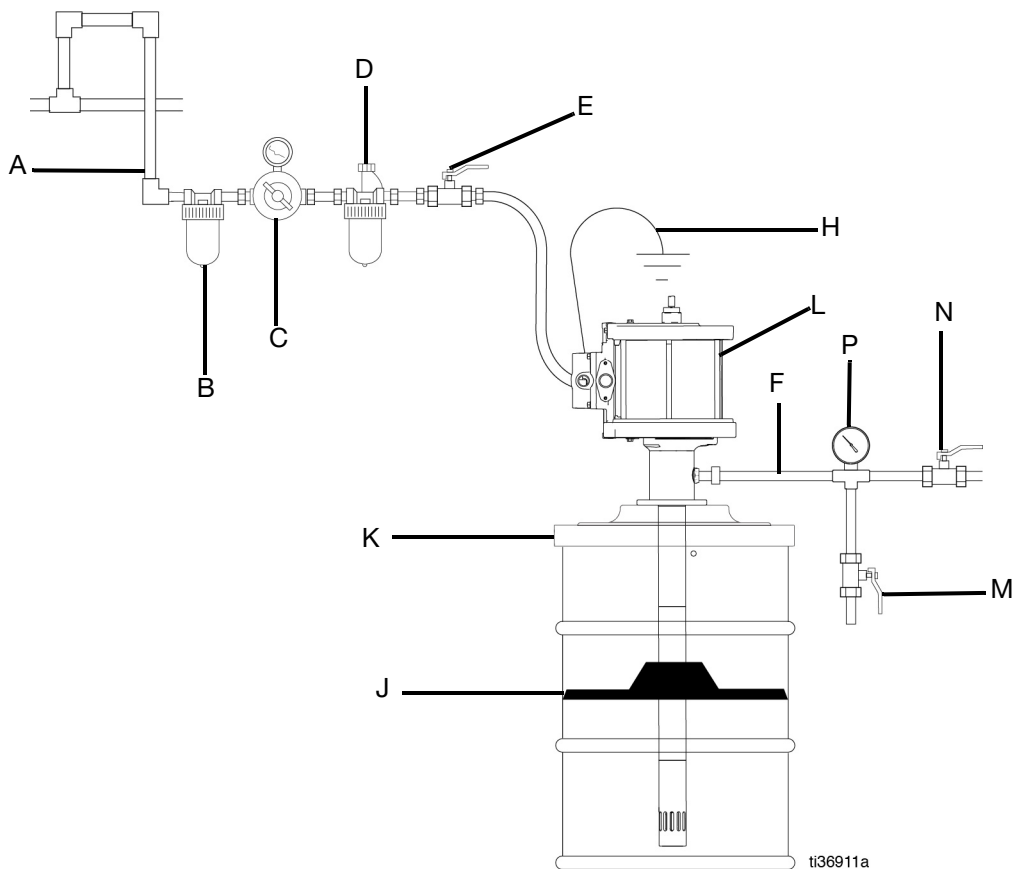

FIG. 1

Key:

- | | | | |
|---|---|---|---------------------------|
| A | Grounded Air Line | K | Drum Cover |
| B | Air Filter (Graco P/N 106150) | L | Air Motor |
| C | Air Regulator (required) (Graco P/N 244845) | M | Drain Valve (required) |
| D | Air Line Oiler (Graco P/N 214849) | N | Shut-off Valve (required) |
| E | Bleed-type Master Air Valve (required) | P | Pressure Gauge (required) |
| F | Fluid Hose | | |
| H | Ground Wire (required) | | |
| J | Follower Plate | | |

Installation Instructions



NOTE: The reference letters in the following instructions refer to **Typical Installation**, page 5.

Mounting the Pump

				
<p>Mount the pump securely so that it cannot move around during operation. Failure to do so could result in personal injury or equipment damage.</p>				

- Select a convenient installation location for the equipment to ensure easy operator access to the pump air controls, sufficient room to change supply containers, and a secure mounting platform.
- For mounting the pump directly onto the supply container, position the pump so that the intake valve is no more than 1 in. (25 mm) from the bottom of the container. Mount the pump to the drum cover (K) or other suitable mounting device.

Pump Accessories

				
<p>Maximum Working Pressure of Accessories</p> <p>To reduce the risk of serious injury including fluid injection and splashing in the eyes or on the skin which may be caused in component ruptures, all accessories added to the pump fluid outlet side must have the following maximum working pressures:</p> <ul style="list-style-type: none"> • Models 25P784 and 25P785: at least 20,000 psi (137.9 MPa, 1379 bar) maximum working pressure. • Models 26A967 and 26A968: at least 12,000 psi (82.7 MPa, 827 bar) maximum working pressure. 				

Drain Valve (M): used to relieve fluid pressure in the pump.



Shut-off Valve (N): used to isolate the pump from downstream fluid pressure.

Fluid Pressure Gauge (P): monitors the fluid outlet pressure.

Air Line Accessories

Install the air line accessories (not supplied) as shown in **Typical Installation**, page 5.

- Install a bleed-type master air valve (E) (required) within easy reach of the pump, downstream from the air regulator (C) (required).
- Install an air filter (B) (optional) to remove harmful dirt and moisture from the compressed air supply. For automatic air motor lubrication,
- Install an air line oiler (D) (optional) close to the pump air inlet.
- Install an air regulator (C) (required) to control the pump speed.

				
<p>A bleed-type master air valve (E) is required to shut off and relieve air pressure that may be trapped in the air motor (L). Trapped air could cause the pump to cycle unexpectedly and cause serious bodily injury, including amputation.</p>				

- Verify that the air hose is properly sized to deliver an adequate supply of air to the motor. Refer to **Technical Specifications**, page 26.

Grounding

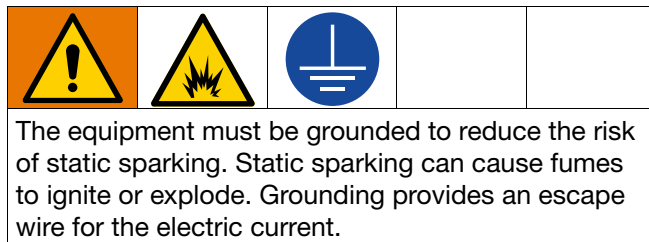

Pump: use ground wire and clamp (Graco P/N 222011, not supplied), as shown in FIG. 2.

1. Connect the ground wire (Y) to the ground screw (Z) located on the bottom of the air motor.
2. Connect the other end of the ground wire (Y) to a true earth ground.

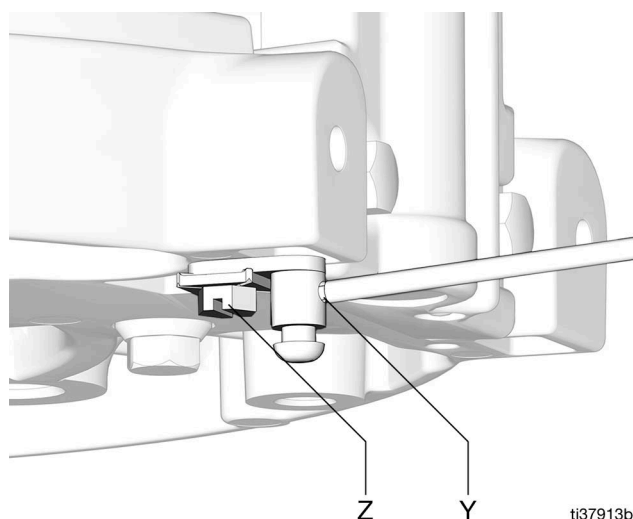

FIG. 2

Air and fluid hoses: use only electrically conductive hoses.

Air compressor: follow manufacturer's recommendations.



Solvent pails used when flushing: follow local code. Use only conductive metal pails, placed on a grounded surface. Do not place the pail on a nonconductive surface, such as paper or cardboard, which interrupts grounding continuity.

To maintain grounding continuity when flushing or relieving pressure: hold metal part of the spray



gun/dispense valve firmly to the side of a grounded metal pail, then trigger the gun/valve.

Operation

NOTE: The reference letters in the following instructions refer to **Typical Installation**, page 5.

				
<p>This pump is designed to be used only in pumping non-corrosive and non-abrasive lubricants. Any other use of the pump can cause unsafe operating conditions and component rupture, which can result in fluid injection or other serious injury or fire or explosion</p>				





Pressure Relief Procedure

				
				
<p>This equipment stays pressurized until pressure is manually relieved. To help prevent serious injury from pressurized fluid, such as skin injection, splashing fluid and moving parts, follow the Pressure Relief Procedure when you stop spraying and before cleaning, checking, or servicing the equipment.</p>				

1. Close the supply pump's bleed-type master air valve (E) (required in the system).
2. Close the shut off valve (N).
3. Open the pump drain valve (M).
4. Check the pressure gauge on the air regulator (C) and the pressure gauge (P) to verify that pressure has been relieved.

Before Starting Pump

NOTE: The reference letters in the following instructions refer to **Typical Installation**, page 5.

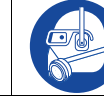
				
<p>COMPONENT RUPTURE HAZARD</p> <p>Overpressurizing any component can result in serious injury or property damage as a result of rupture, fire, and/or explosion. The maximum working pressure of each component in the system may not be the same, To reduce the risk of overpressurizing any component in the system:</p> <ul style="list-style-type: none"> • Be sure you know the maximum working pressure of each component. • Never exceed the maximum working pressure of the lowest rated component in the system. • Do not exceed the maximum input pressure. • Use tubing, hoses, and other components with pressure ratings equal to or higher than the pump rating. • Do not exceed the maximum output pressure. For example, the Dyna-Star 200:1 pump has a rated ratio of 200:1. To calculate the fluid output pressure, multiply the air pressure shown on the pressure gauge of the air regulator (C) by 200. $100 \text{ psi air} \times 200 = 20,000 \text{ psi fluid output}$ $0.69 \text{ MPa air} \times 200 = 137.9 \text{ MPa fluid output}$ • Do not exceed the maximum pump cycle rate. • Use the required air regulator (C) to regulate air pressure to the pump so that no fluid line component or accessory is over pressurized. 				

Priming and Pump Speed Adjustment

NOTE: The reference letters in the following instructions refer to **Typical Installation**, page 5.



1. Open the bleed-type master air valve (E).
2. Open the drain valve (M), and slowly open the air regulator (C) until the pump is running smoothly.
3. After all of the air is purged from the fluid hose, close the drain valve (M).
4. Use the air regulator (C) to control the pump speed and fluid pressure. Always use the lowest pressure necessary to obtain the desired results.
5. The pump will start and stop as the shut-off valve (N) is opened and closed.

NOTICE

Never allow the pump to run dry of the fluid being pumped. A dry pump quickly accelerates to a high speed and may cause damage to the pump seals.

6. If the pump accelerates quickly or is running too fast, immediately stop the pump by closing the bleed-type master air valve (E) and check the fluid supply. If the supply container is empty and air has been pumped into the lines:
 - a. Refill the supply container.
 - b. Prime the pump and fill the lines with fluid to remove all of the air from the fluid lines.

Maintenance

Suggested tools

- 1/8 in. hex key
- 3/4 in. socket
- 15/16 in. socket
- 15/16 in. open-end wrench
- 1-7/16 in. socket
- 1-13/16 in. socket
- 1-15/16 in. socket
- 2 in. socket
- socket extension
- O-ring pick
- Torque wrench (50 - 250 ft-lb/ 67.8 - 339 N•m)
- Torque wrench (70 in-lb/ 7.9 N•m)
- Large adjustable wrenches (1-1/4 in. jaw capacity)

Disassemble

1. Close the bleed type master air valve (E, FIG. 1) to stall the pump while it is in the down stroke position (FIG. 3).

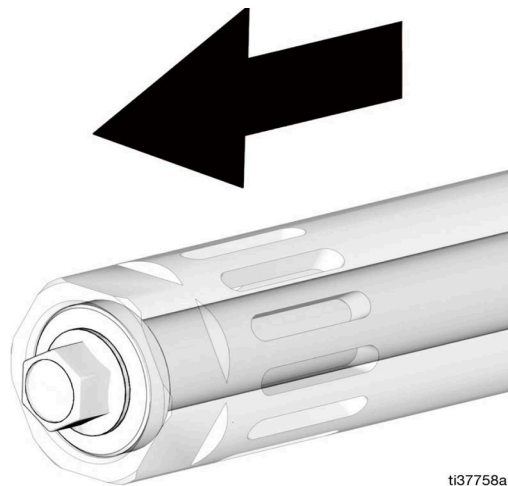

FIG. 3

2. Relieve pressure following the **Pressure Relief Procedure**, page 8.
3. Disconnect the air supply hose from the pump air motor (1).
4. Disconnect the fluid hose.
5. Remove the pump from the container and place on a workbench.

6. Remove the muffler (27).

NOTE: Removing the muffler (27) allows easier movement of the internal pump components to expose the flats.

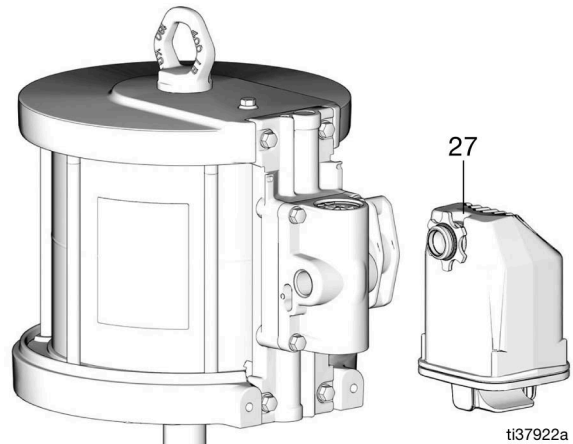

FIG. 4

7. Remove the four screws (31) holding the mounting flange (7) using 1/8 in. hex key (FIG. 5).
8. Remove the mounting flange (7), exposing the flats (FIG. 5).

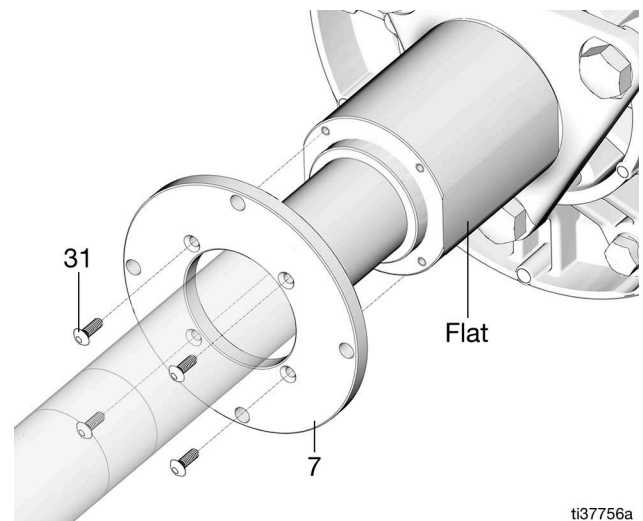

FIG. 5

9. Position the pump horizontally into a vise and secure on the flats (FIG. 6).

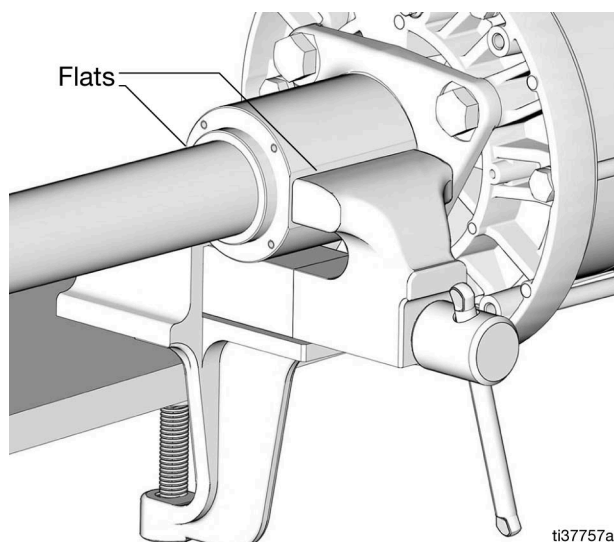

FIG. 6

NOTE: Alternative Vice Mounting Orientation: position pump horizontally into a vise and secure the air motor (FIG. 7).

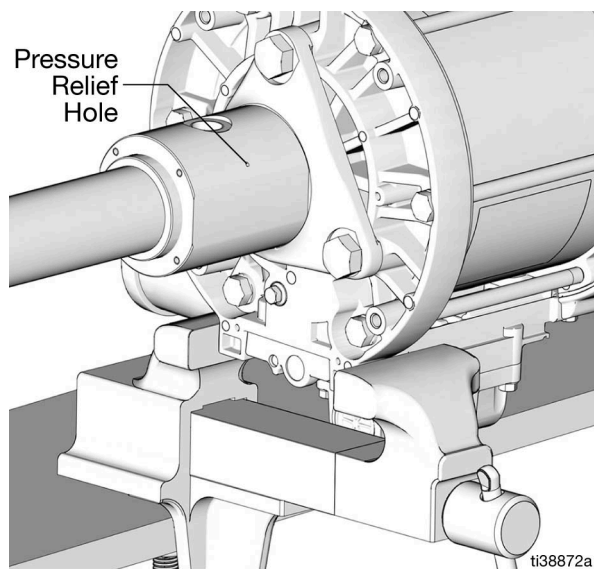

FIG. 7

10. Using a 1-15/16 in. socket, loosen the inlet pump cylinder (8) and expose the hex on the connecting rod (13) (FIG. 8).

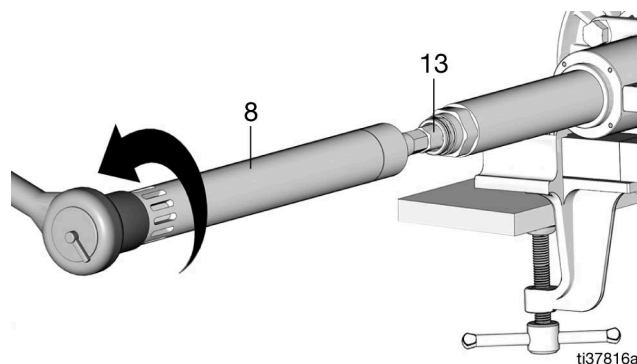

FIG. 8

11. Using a 3/4 in. wrench, loosen and unthread the shovel rod (20), leaving the shovel rod inside of the inlet pump cylinder (8) (FIG. 9) and set aside.

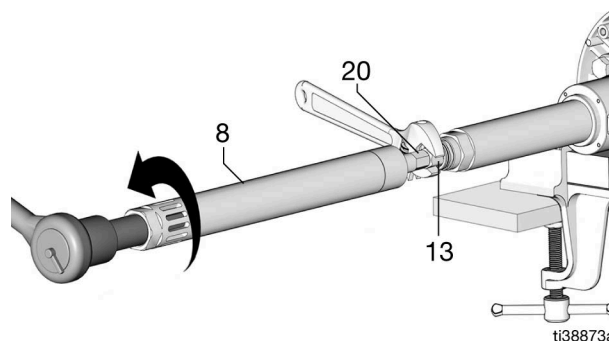

FIG. 9

12. Using a 1-7/16 in. socket, loosen the seal retainer (6) but leave it hand-tight to the pump cylinder (2) (FIG. 10).

NOTE: Push the connecting rod in to allow the socket to reach hex on the seal retainer.

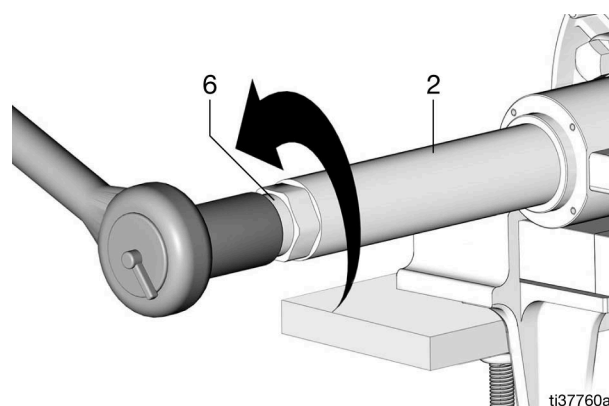

FIG. 10

- Using a 1-13/16 in. socket, slowly turn until it is loose, then continue removal of the pump cylinder (2) by hand (FIG. 11).

NOTE: Be careful while threading and unthreading to avoid damage and voiding the warranty.

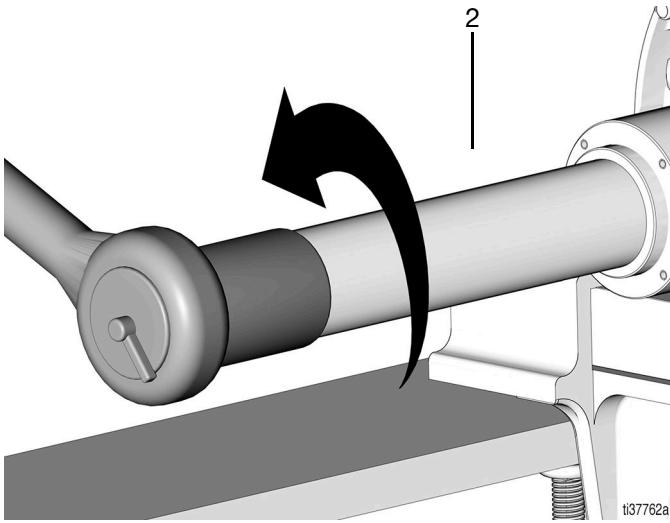

FIG. 11

- Position a wrench on the displacement rod (14) flats and position another wrench on the fluid piston (9) flats. Loosen and remove the fluid piston (9) (FIG. 12).

NOTE: The fluid piston (9) can stay connected to the connecting rod (13).

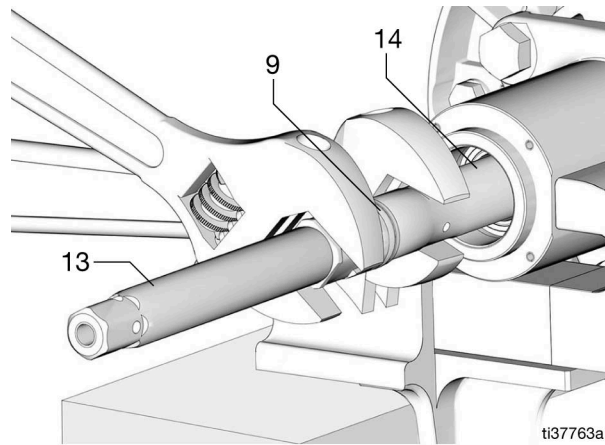

FIG. 12

- Remove the check ball (15) from inside of the displacement rod (14) and set aside (FIG. 13).

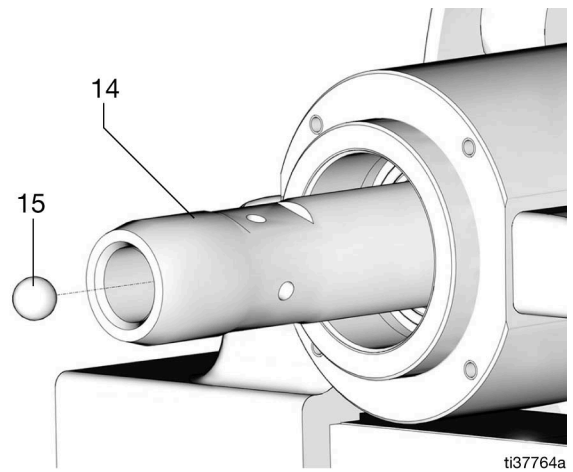

FIG. 13

- Loosen and remove the three outlet housing adapter screws (17) using a 15/16 in. wrench (FIG. 14).

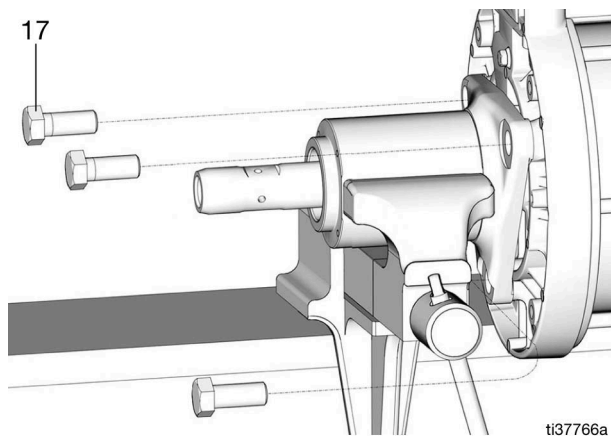

FIG. 14

17. Remove the air motor (1) (FIG. 15).

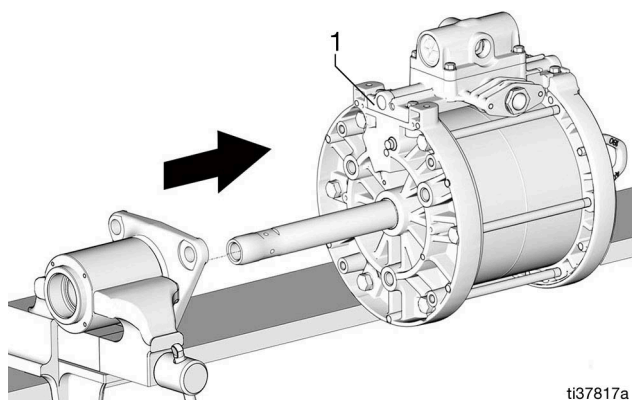

FIG. 15

18. Using a 2 in. socket, loosen and remove the throat seal retainer nut (19) (FIG. 16).

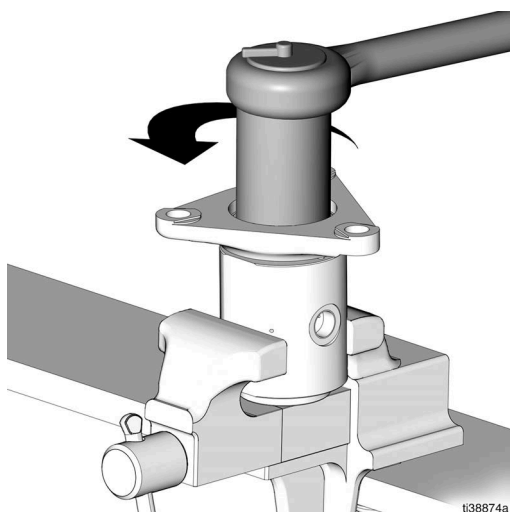

FIG. 16

19. Remove the outlet housing adapter (16) (FIG. 17).
20. Remove the spacer (35), throat seal (5) and the throat seal back-up rings (4) (FIG. 17).
21. Remove the o-ring face seal (18) (FIG. 17).

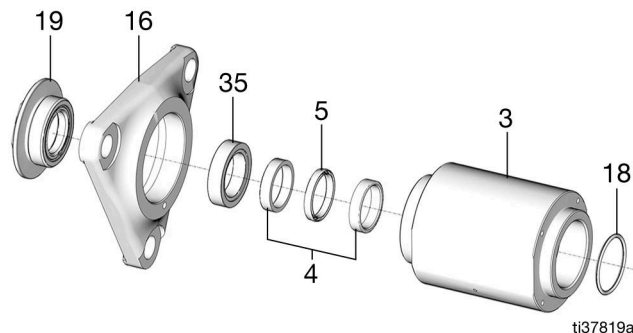

FIG. 17

Reassemble

1. Replace the o-ring face seal (18) with a new one from the seal kit (FIG. 18).
2. Replace the backup throat seal (34) with a new one from the seal kit (FIG. 18),
3. Replace the throat seal (5) and the throat seal back-up rings (4) with new parts from the seal kit (FIG. 18).

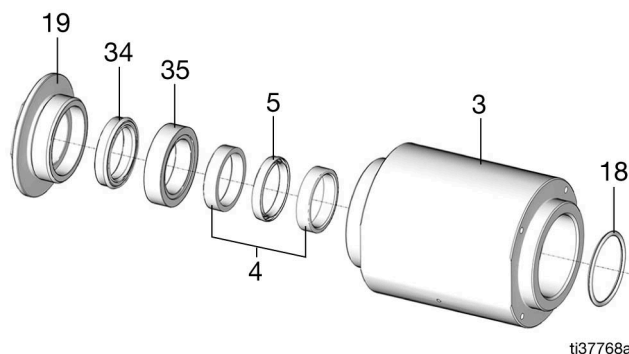

FIG. 18

NOTE: The chamfer on the seal back-up rings must be pointing away from the seal, the step on the spacer must be pointing toward the back-up rings. (FIG. 19).

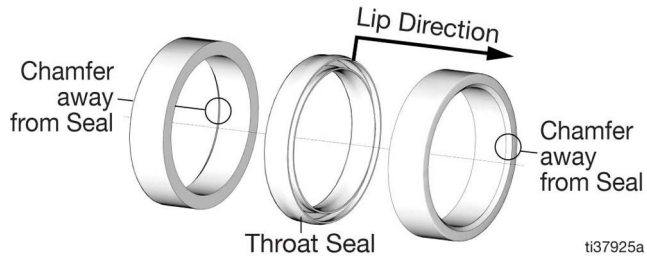

FIG. 19

4. Reinstall the outlet housing adapter by lining up the hole in the adapter with the pin on the outlet housing (FIG. 20).

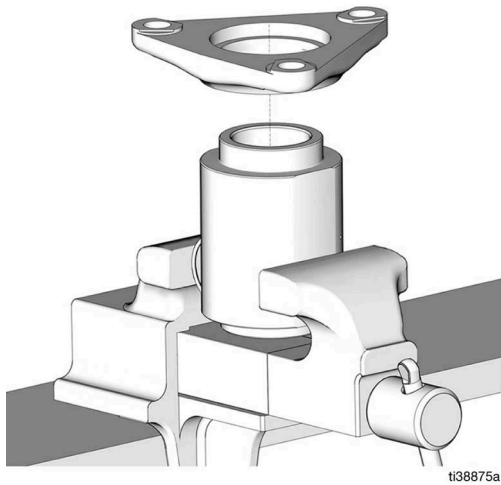

FIG. 20

5. Using a 2 in. socket, reinstall the throat seal retainer nut (19) and tighten (torque 150 - 165 ft-lb/203.4 - 223.7 N•m) (FIG. 21).

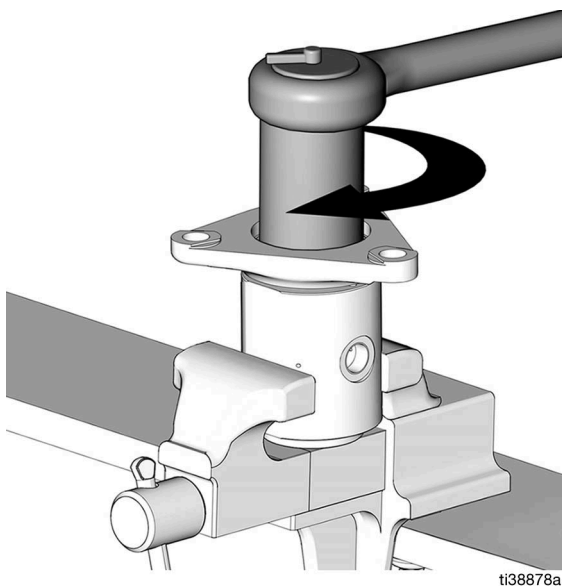

FIG. 21

6. Reinstall the air motor (1) by sliding the displacement rod (14) through the outlet housing (3) (FIG. 22).

NOTE: Reinstall the air motor in the preferred orientation for air line connection.

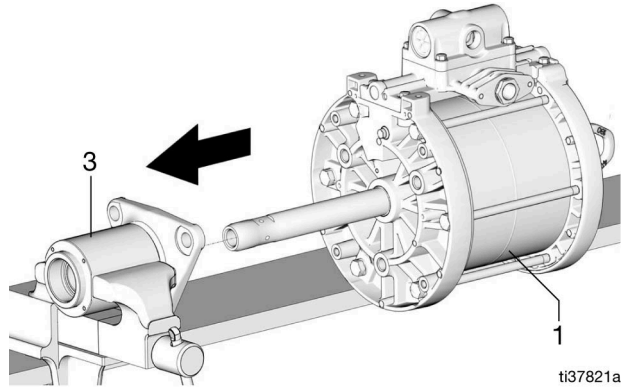

FIG. 22

7. Replace and hand-tighten the outlet housing adapter screws (17) (FIG. 23).

NOTE: Do not fully tighten the housing adapter screws (17) in Step 7. The outlet housing needs to be able to self-align with the pump tube during reinstalling and torquing in Step 15, or the pump tube threads may gall, which could damage both components.

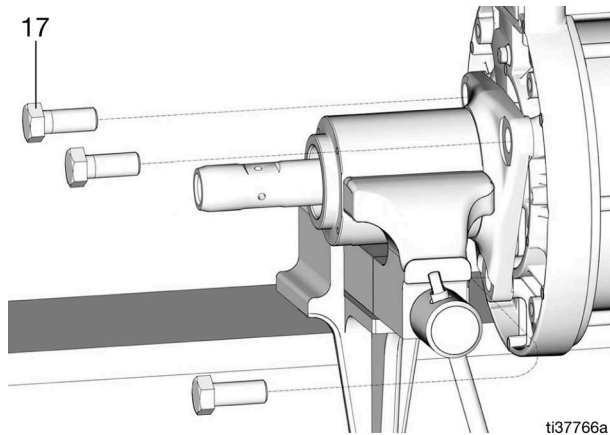

FIG. 23

- Replace the check ball (15) between the displacement rod (14) and the fluid piston (9) (FIG. 24).

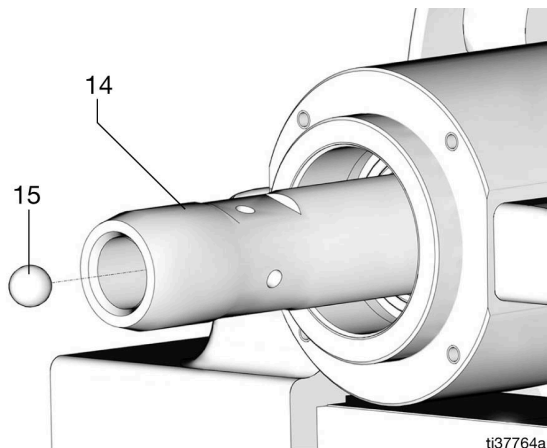

FIG. 24

- Remove the piston seal retainer (12), the piston seal (11), and the piston seal back-up rings (10), and replace with new parts from the seal repair kit (FIG. 25).

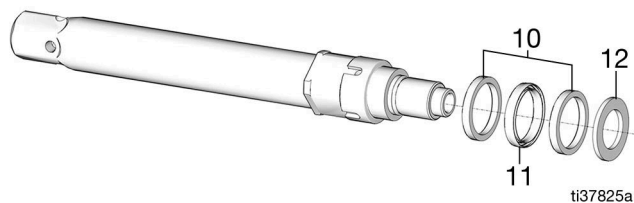

FIG. 25

NOTE:

- The chamfer on the seal back-up ring must be pointing away from the seal (FIG. 26).
- The piston seal has a green o-ring.

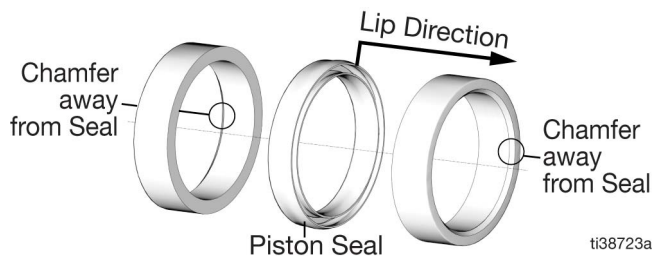

FIG. 26

- Reinstall the fluid piston (9) and the connecting rod (13) using one wrench on the displacement rod flat and a 15/16 in. socket on the connecting rod (13) and then tighten (torque 140 - 160 ft-lb/189.8 - 216.9 N•m) (FIG. 27).

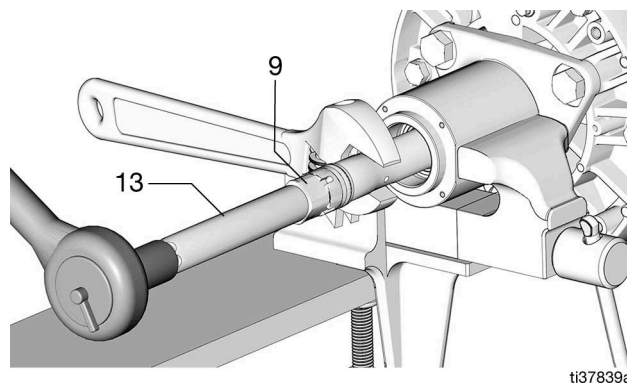

FIG. 27

- Remove the seal retainer (6) from the pump cylinder (2) (FIG. 29).
- Remove the priming seal (30) and the priming seal back-up rings (29) and replace with new parts from the seal repair kit (FIG. 29).

NOTE:

- The chamfer on the seal back-up rings must be pointing away from the seal (FIG. 28).
- The priming seal has a yellow o-ring.
- Priming seal back-up rings have identification marks on the chamfered face to distinguish it from the piston seal back-up rings.

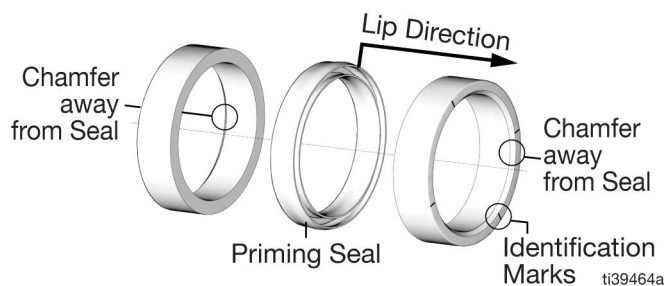

FIG. 28

- Replace the o-rings (28) on the seal retainer (6) using the parts from the seal repair kit (FIG. 29).

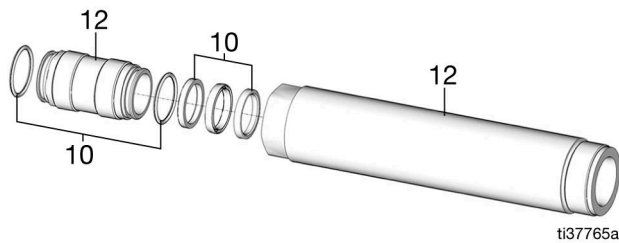

FIG. 29

- Replace the seal retainer (6) and hand-tighten (FIG. 30).

- Apply non-metallic, anti-seize lubricant to the male threads of the pump cylinder (2) then start reassembly by hand until tight, then finish using a 1-13/16 in. socket (torque 235 - 265 ft-lb/318.6 - 359.3 N•m).

NOTE: Be careful while threading and unthreading to avoid damage and voiding the warranty.

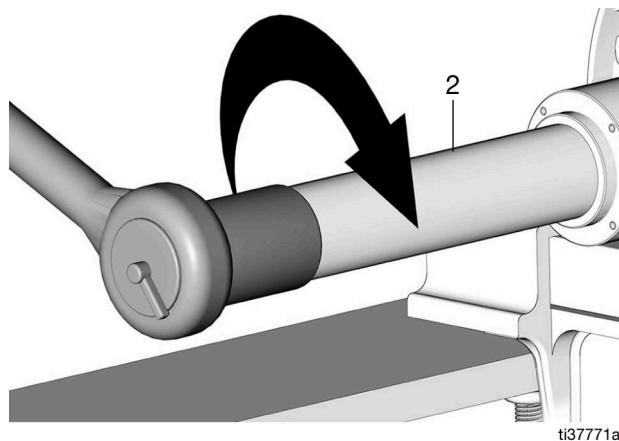

FIG. 30

- Using a 1-7/16 in. socket, tighten the seal retainer (6) to the pump cylinder (2) assembly (torque 100 - 110 ft-lb/135.6 - 149.1 N•m) (FIG. 31).

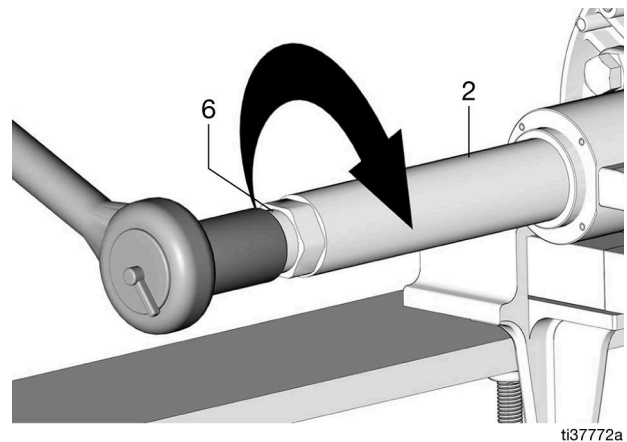

FIG. 31

- Reinstall the inlet pump tube assembly, connect the shovel rod (20), located inside of the inlet pump tube (8), and attach to the connecting rod (13) using a 3/4 in. socket and tighten (torque 50 - 60 ft-lb/ 67.8 - 81.3 N•m) (FIG. 32).

NOTE: The shovel rod (20) should remain inside of the inlet pump cylinder (8).

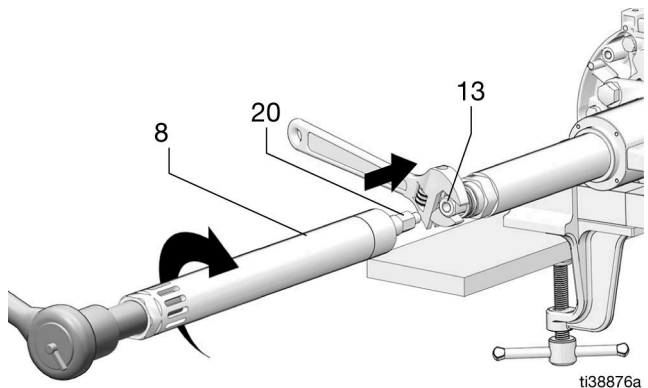
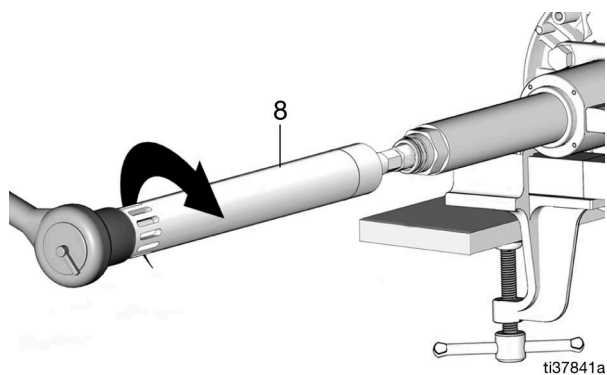

FIG. 32

- Reinstall the inlet cylinder (8) and tighten using a 1-15/16 in. socket (torque 75 - 85 ft-lb/101.7 - 115.2 N•m) (FIG. 33).

NOTE: Remove any grease on the internal threads of the inlet cylinder before reinstalling to ensure correct threading.

**FIG. 33**

19. Reconnect the muffler (27).
20. Attach air supply hose to the pump air motor.
21. Apply air and slowly cycle several times.
22. Remove the air supply hose.
23. Tighten the outlet housing adapter bolts using a 15/16 in. socket (torque 55 - 65 ft-lb/74.68 - 88.1 N•m).

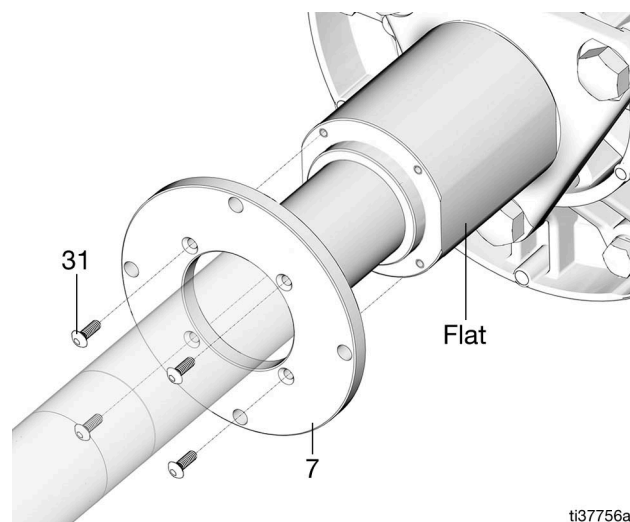
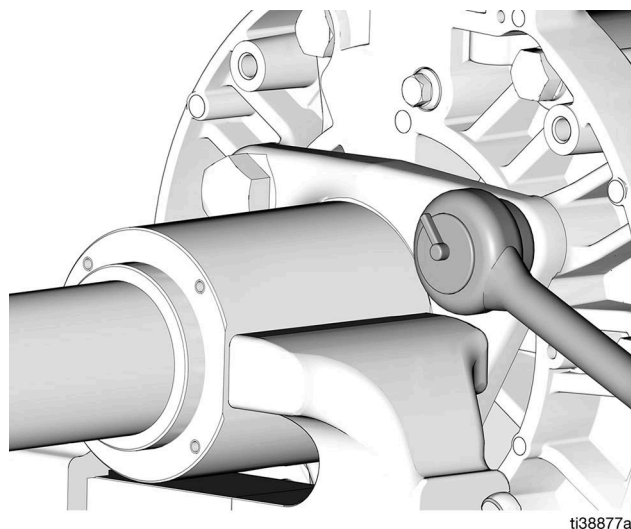
**FIG. 35****FIG. 34**

24. Remove the pump from the vise.
25. Replace the mounting plate (FIG. 35).
26. Replace the four screws holding the mounting flange (7) (torque 60 - 70 in-lb/6.8 - 7.9 N•m) (FIG. 35).

Recycling and Disposal

End of Product Life

At the end of the product's useful life, dismantle and recycle it in a responsible manner.

- Perform the **Pressure Relief Procedure**.
- Drain and dispose of fluids according to applicable regulations. Refer to the material manufacturer's Safety Data Sheet.
- Deliver remaining product to a recycling facility.

Troubleshooting



1. Follow **Pressure Relief Procedure**, page 8, before checking or making repairs repairing to the pump.
2. Check all possible problems and causes before disassembling the pump.

Problem	Cause	Solution
Pump fails to operate or there is no fluid flow.	Inadequate air supply pressure	Increase the air supply.
	Restricted air line	Clear the line.
	Closed dispense valves	Open the valve.
	Clogged fluid lines, hoses, and/or dispense valve	<ol style="list-style-type: none"> 1. Disconnect the fluid line. 2. Turn the air on. If the pump starts, the line, hose, and/or valve is clogged. Clear the obstruction.
	Damaged air motor	Service the air motor. See the Dyna-Star Air Motor manual.
	Exhausted fluid supply	Refill the fluid supply and prime or flush.
Continuous air exhaust.	Worn or damaged air motor gasket, packing, seal, etc.	Service the air motor. See the Dyna-Star Air Motor manual.
Erratic pump operation.	Exhausted fluid supply	Refill the fluid supply and prime or flush.
	Worn fluid seals	Replace worn seals. See Parts , beginning on page 20.
	Inadequate air supply pressure.	Increase the air supply.
Pump operates but the output is low on the down or up stroke.	Worn fluid seals	Replace worn seals. See Parts , beginning on page 20.
Fluid is coming out of the gap between either the air motor and the housing adapter or the housing adapter and the outlet housing.	Worn or damaged throat seal.	Replace worn seals. See Parts , beginning on page 20.
Leak at output pressure relief hole (see FIG. 7, page 11).	Wrong style of fitting	Install the correct fitting.
	Fitting is loose	Tighten the fitting.
	Fitting is damaged	Replace the fitting.

Parts

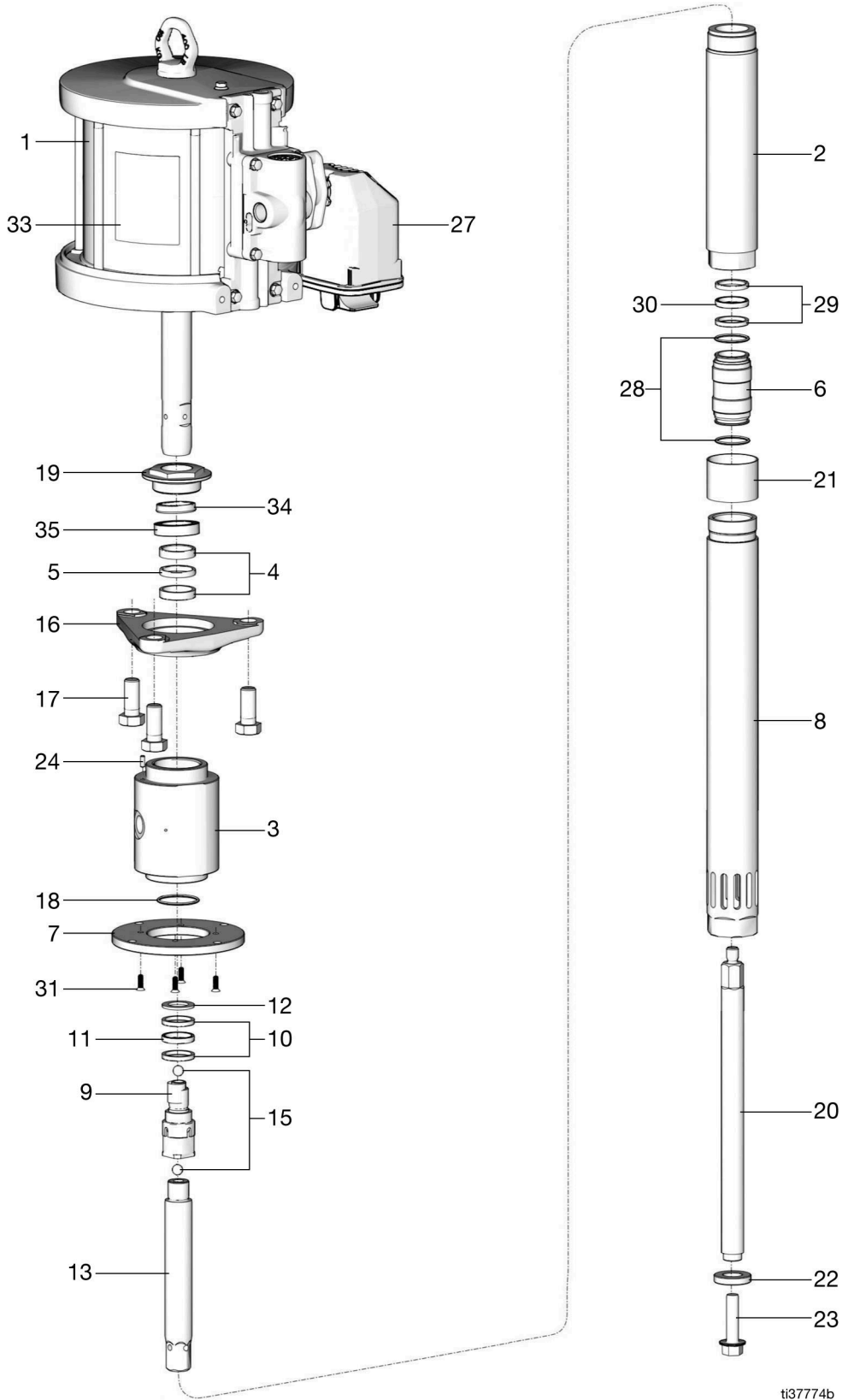

ti37774b

Part Number/Assembly Name

Ref.	Part	Description	Qty.
1	25T843	MOTOR, assy, air, 7.5 in.	1
	25T844	MOTOR, assy, air, 6.0 in.	1
2‡		CYLINDER, pump	1
3*		HOUSING, outlet	1
4*		RING, back-up, throat seal	2
5*		SEAL, throat	1
6‡		RETAINER, seal	1
7*		FLANGE, mounting	1
8†		CYLINDER, inlet, 400 lb, model 25P785, 26A968	1
♣		CYLINDER, inlet, 120 lb, model 25P784, 26A967	1
9♣		PISTON, fluid	1
10*		RING, back-up, piston seal	2
11*		SEAL, piston	1
12*		WASHER, retainer	1
13♣		ROD, connecting	1
14		ROD, displacement	1
15♣	100114	BALL, check	2
16*		ADAPTER, housing	1
17	123208	SCREW, cap, hex head	3
18*		SEAL, o-ring	1
19*		RETAINER, nut	1
20†		ROD, shovel, 400 lb, model 25P785, 26A968	1
♣		ROD, shovel, 120 lb, model 25P784, 26A967	1
21♣†	26A953	SLEEVE, cylinder	1
22♣†	25P115	SHOVEL, priming	1
23♣†		SCREW, head, washer, hex	1
24*		PIN, dowel	1
27	24D642	MUFFLER	1
28*		SEAL, o-ring	2
29*		RING, back-up, priming seal	2
30*		SEAL, priming	1
31*		SCREW, flat HD	4
32		LABEL, identification	1
33▲		LABEL, safety warning	1
34*		SEAL, throat seal, back-up	1
35*		SPACER	1

▲ Replacement safety labels, tags, and cards are available at no cost.

* Parts included in Seal Repair Kit 26B069 (purchase separately).

♣ Parts included in 120 lb. drum length conversion kit 26B416, see page 22.

‡ Parts included in 400 lb. drum length conversion kit 26B399, see page 22.

† Parts included in Pump Tube Kit 25T854 (purchase separately).

♣ Parts included in Fluid Piston Kit 25T855 (purchase separately).

* Parts included in Outlet Housing Kit 25T856 (purchase separately).

Accessories

Part Number	Description
25U200	PLATE, follower, 400 lb.
25U201	PLATE, follower, 120 lb.
25U202	COVER, drum, 400 lb.
25U203	COVER, drum, 120 lb.
24A592	KIT, DataTrak [®] cycle count
129870	Outlet Adapter (1/2 npt female x 9/16 mp male)

Length Conversion Kits

Part Number	Description
26B399	KIT, Conversion, 400 lb. drum length
26B416	KIT, Conversion, 120 lb. drum length

Performance Charts

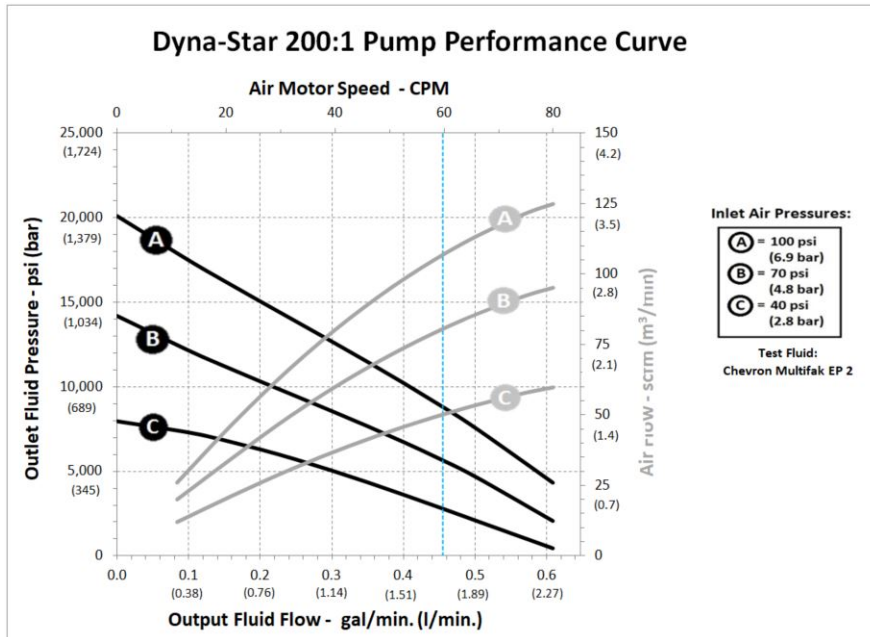
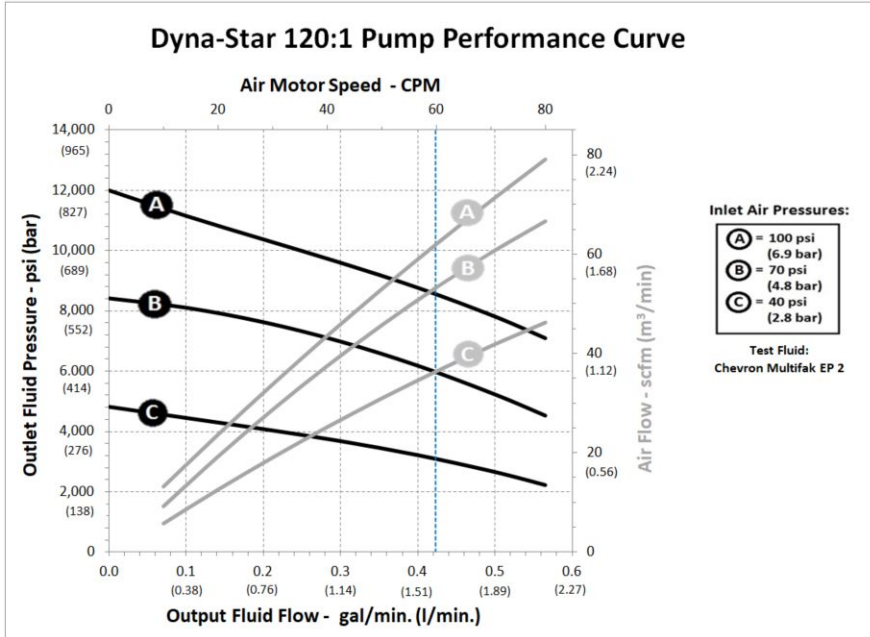

Dimensions

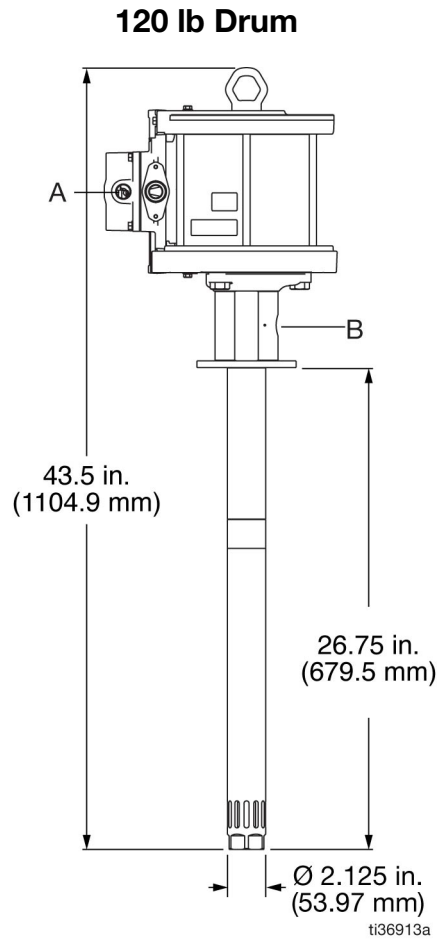
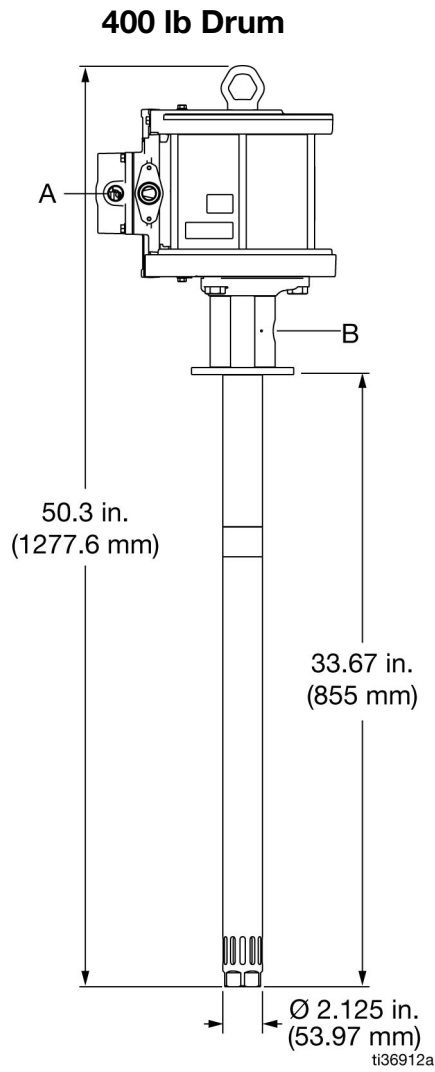

Dimension Table

Ref	Description
A	Air Inlet, 1/2 inch NPT
B	Fluid Outlet, 13/16 - 16 inch UNC

Mounting Hole Layout

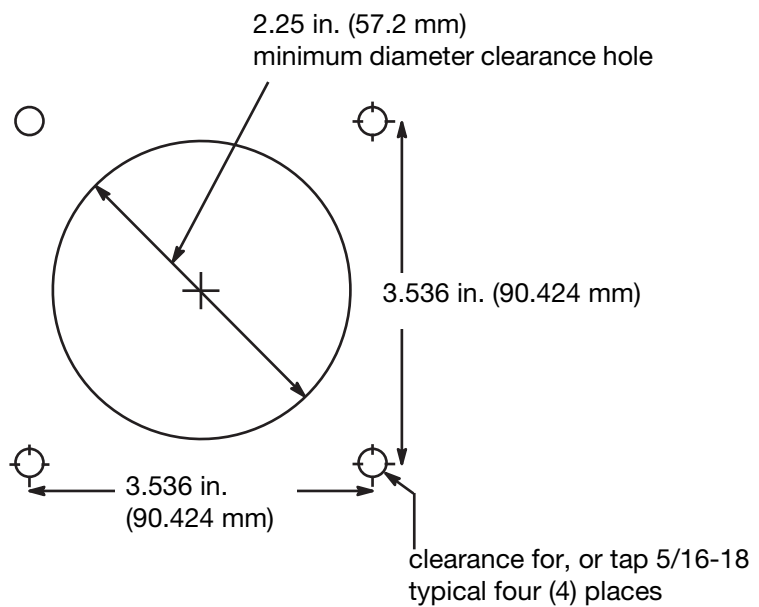

Technical Specifications

Dyna-Star 200:1 Pump		
	US	Metric
Fluid Pressure Ratio	200:1	
Maximum Air Pressure	100 PSI	0.69 MPa, 6.89 bar
Maximum Working Pressure	20,000 PSI	137.9 MPa, 1379 bar
Maximum Recommended Pump Speed:	60 cycles per minute	
Air Inlet	1/2 in. NPT	
Maximum Fluid Temperature	180°F	82°C
Fluid Outlet	13/16 - 16 UNC - Medium Pressure coned and threaded connection	
Air Motor Effective Diameter	7.5 in.	190 mm
Stroke	4.75 in.	121 mm
Fluid Output at 60 cycles per minute	0.45 gal per min.	1.7 L per min.
Wetted Parts	Steel, stainless steel, bronze, UHMWPE, aluminum	
Noise (dBa)		
Sound Power*	77.2 dBa	
Sound Pressure**	70.5 dBa	
<i>*Sound power at 70 psi (0.48 MPa, 4.8 bar), 20 cpm. Sound power measured per ISO-9614-2.</i>		
<i>**Sound pressure measured 3.28 feet (1.0 meter) from equipment.</i>		
Pump Weight		
400# Length	70 lb	31.8 kg
120# Length	65 lb	29.5 kg

Dyna-Star 120:1 Pump		
	US	Metric
Fluid Pressure Ratio	120:1	
Maximum Air Pressure	100 PSI	0.69 MPa, 6.89 bar
Maximum Working Pressure	12,000 PSI	82.7 MPa, 827 bar
Maximum Recommended Pump Speed:	60 cycles per minute	
Air Inlet	1/2 in. NPT	
Maximum Fluid Temperature	180°F	82°C
Fluid Outlet	13/16 - 16 UNC - Medium Pressure coned and threaded connection	
Air Motor Effective Diameter	6.0 in.	152.4 mm
Stroke	4.75 in.	121 mm
Fluid Output at 60 cycles per minute	0.45 gal per min.	1.7 L per min.
Wetted Parts	Steel, stainless steel, bronze, UHMWPE, aluminum	
Noise (dBa)		
Sound Power*	77.5 dBa	
Sound Pressure**	70.7 dBa	
<i>*Sound power at 70 psi (0.48 MPa, 4.8 bar), 20 cpm. Sound power measured per ISO-9614-2.</i>		
<i>**Sound pressure measured 3.28 feet (1.0 meter) from equipment.</i>		
Pump Weight		
400# Length	64 lb	29.0 kg
120# Length	59 lb	26.8 kg

California Proposition 65

CALIFORNIA RESIDENTS

 **WARNING:** Cancer and reproductive harm – www.P65warnings.ca.gov.

Graco Standard Warranty

Graco warrants all equipment referenced in this document which is manufactured by Graco and bearing its name to be free from defects in material and workmanship on the date of sale to the original purchaser for use. With the exception of any special, extended, or limited warranty published by Graco, Graco will, for a period of twelve months from the date of sale, repair or replace any part of the equipment determined by Graco to be defective. This warranty applies only when the equipment is installed, operated and maintained in accordance with Graco's written recommendations.

This warranty does not cover, and Graco shall not be liable for general wear and tear, or any malfunction, damage or wear caused by faulty installation, misapplication, abrasion, corrosion, inadequate or improper maintenance, negligence, accident, tampering, or substitution of non-Graco component parts. Nor shall Graco be liable for malfunction, damage or wear caused by the incompatibility of Graco equipment with structures, accessories, equipment or materials not supplied by Graco, or the improper design, manufacture, installation, operation or maintenance of structures, accessories, equipment or materials not supplied by Graco.

This warranty is conditioned upon the prepaid return of the equipment claimed to be defective to an authorized Graco distributor for verification of the claimed defect. If the claimed defect is verified, Graco will repair or replace free of charge any defective parts. The equipment will be returned to the original purchaser transportation prepaid. If inspection of the equipment does not disclose any defect in material or workmanship, repairs will be made at a reasonable charge, which charges may include the costs of parts, labor, and transportation.

THIS WARRANTY IS EXCLUSIVE, AND IS IN LIEU OF ANY OTHER WARRANTIES, EXPRESS OR IMPLIED, INCLUDING BUT NOT LIMITED TO WARRANTY OF MERCHANTABILITY OR WARRANTY OF FITNESS FOR A PARTICULAR PURPOSE.

Graco's sole obligation and buyer's sole remedy for any breach of warranty shall be as set forth above. The buyer agrees that no other remedy (including, but not limited to, incidental or consequential damages for lost profits, lost sales, injury to person or property, or any other incidental or consequential loss) shall be available. Any action for breach of warranty must be brought within two (2) years of the date of sale.

GRACO MAKES NO WARRANTY, AND DISCLAIMS ALL IMPLIED WARRANTIES OF MERCHANTABILITY AND FITNESS FOR A PARTICULAR PURPOSE, IN CONNECTION WITH ACCESSORIES, EQUIPMENT, MATERIALS OR COMPONENTS SOLD BUT NOT MANUFACTURED BY GRACO. These items sold, but not manufactured by Graco (such as electric motors, switches, hose, etc.), are subject to the warranty, if any, of their manufacturer. Graco will provide purchaser with reasonable assistance in making any claim for breach of these warranties.

In no event will Graco be liable for indirect, incidental, special or consequential damages resulting from Graco supplying equipment hereunder, or the furnishing, performance, or use of any products or other goods sold hereto, whether due to a breach of contract, breach of warranty, the negligence of Graco, or otherwise.

FOR GRACO CANADA CUSTOMERS

The Parties acknowledge that they have required that the present document, as well as all documents, notices and legal proceedings entered into, given or instituted pursuant hereto or relating directly or indirectly hereto, be drawn up in English. Les parties reconnaissent avoir convenu que la rédaction du présente document sera en Anglais, ainsi que tous documents, avis et procédures judiciaires exécutés, donnés ou intentés, à la suite de ou en rapport, directement ou indirectement, avec les procédures concernées.

Graco Information

For the latest information about Graco products, visit www.graco.com.

For patent information, see www.graco.com/patents.

TO PLACE AN ORDER, contact your Graco distributor or call to identify the nearest distributor.

Phone: 612-623-6928 **or Toll Free:** 1-800-533-9655, **Fax:** 612-378-3590

*All written and visual data contained in this document reflects the latest product information available at the time of publication.
Graco reserves the right to make changes at any time without notice.*

Original instructions. This manual contains English. MM 3A7519

Graco Headquarters: Minneapolis

International Offices: Belgium, China, Japan, Korea

GRACO INC. AND SUBSIDIARIES • P.O. BOX 1441 • MINNEAPOLIS MN 55440-1441 • USA
Copyright 2020, Graco Inc. All Graco manufacturing locations are registered to ISO 9001.

www.graco.com
Revision E, November 2024