

PerformAA™ Spray Gun

3A8099C

EN

Air assist and airless spray guns for fine finish application of various solventborne and waterborne paints and coatings. For professional use only.

100 psi (0.7MPa, 7 bar) maximum working air pressure.

See page 3 for model information including maximum working fluid pressure.



Important Safety Instructions

Read all warnings and instructions in this manual before using the equipment. Save these instructions.



Important Medical Information

Read the medical alert card provided with the gun. It contains injection injury treatment information for a doctor. Keep it with you when operating the equipment.

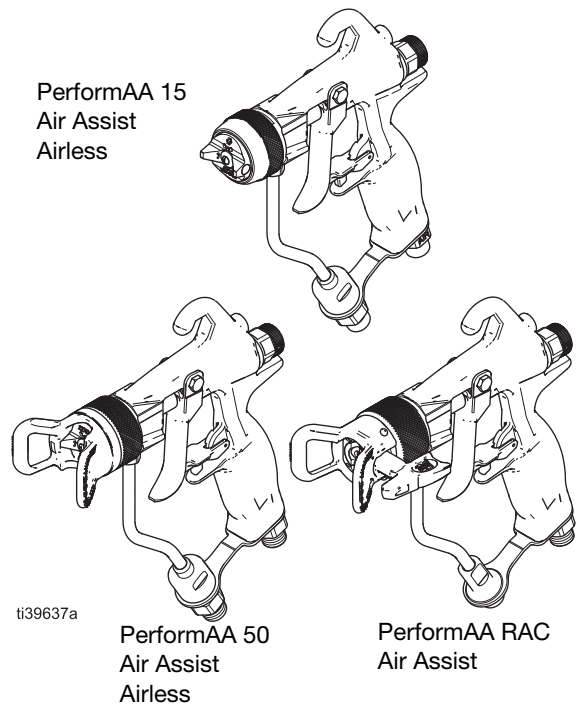

Contents

Models	3	Repair	30
Warnings	5	Air Cartridge Replacement Procedure	30
Spray Gun Overview	7	Trigger Procedure	30
Component Identification	8	Air Cap Assembly Repair Procedure	31
Typical Installation	9	U-Cup Replacement Procedure	31
Typical Installation Accessories	10	Air Cartridge Repair	32
Setup	11	Fan Tube Replacement	34
Ventilate the Spray Booth	11	Fluid Cartridge Replacement	34
Ground the Spray Gun	11	Fluid Cartridge Repair	35
Connect the Spray Gun	11	Spray Tip Gasket Replacement	39
Flush Before Using	12	RAC Conversion Instructions	39
Spray Tip and Air Cap Setup	13	Parts	40
Reverse-A-Clean® (RAC) Setup	14	PerformAA 15 Air Assist Gun Models	40
Operation	15	PerformAA 50 Air Assist Gun Models	42
Pressure Relief Procedure	15	PerformAA RAC Air Assist Gun Models	44
Trigger Lock	15	PerformAA Airless Gun Models	46
Spray Gun Operation	15	Air Cartridge Assembly	48
Spray Gun Operation Procedure	16	Fluid Cartridge Assembly	49
Spray Finishing Application	18	Fluid Cartridge Identification	50
Maintenance	19	Fluid Tube Assembly Parts	51
Daily Gun Care	19	Spray Tip Charts	52
Flushing Procedure	21	PerformAA 15, PerformAA 50, and	
Inline Fluid Filter Cleaning Procedure	21	PerformAA Airless Spray Tips	52
Cleaning Procedure	22	PerformAA RAC SwitchTips	55
Reverse-A-Clean (RAC) Tip Maintenance	24	Air Cap Selection Guide	56
Troubleshooting	25	Air Flow	57
Spray Pattern Troubleshooting	25	Kits and Accessories	58
Air Leak Troubleshooting	28	Dimensions	61
Fluid Troubleshooting	29	Technical Specifications	64
		California Proposition 65	65
		Graco Standard Warranty	66

Models

PerformAA™ 15 Air Assist Gun Models

Medium-pressure gun includes carbide seat and ball, 100 mesh inline fluid filter, indexing air cap, and choice of AXM or AXF spray tip (unless otherwise noted).

Model	Maximum Working Fluid Pressure psi (MPa, bar)	Air Cap	Air Cap Part Number	Includes Fluid Swivel Connector
26B500	1500 (10.5, 105)	General Finishing (GF)	2GF042	
26B501	1500 (10.5, 105)	General Finishing (GF)	2GF042	✓
26B502	1500 (10.5, 105)	Wood Lacquer (WL)	2WL042	
26B503	1500 (10.5, 105)	Wood Lacquer (WL)	2WL042	✓
26B505	1500 (10.5, 105)	Low Viscosity (LV)	2LV042	✓
26B504*	1500 (10.5, 105)	General Finishing (GF)	2GF042	

*Gun with a plastic seat, stainless steel Ball

PerformAA™ 50 Air Assist Gun Models

High-pressure gun includes carbide seat and ball, 100 mesh inline fluid filter, and choice of AXM or AXF spray tip (unless otherwise noted).

Model	Maximum Working Fluid Pressure psi (MPa, bar)	Air Cap	Air Cap Part Number	Includes Fluid Swivel Connector
26B510	5000 (34.5, 345)	General Finishing (GF)	2GF042	
26B511	5000 (34.5, 345)	General Finishing (GF)	2GF042	✓
26B512	5000 (34.5, 345)	Wood Lacquer (WL)	2WL042	✓
26B513	5000 (34.5, 345)	High Viscosity (HV)	2HV042	✓
26B514	5000 (34.5, 345)	Waterborne (WB)	2WB042	✓
26B515	5000 (34.5, 345)	Quick Drying (QD)	2QD042	✓
26B516	5000 (34.5, 345)	Low Viscosity (LV)	2LV042	✓
26B509*	5000 (34.5, 345)	General Finishing (GF)	2GF042	

*Gun with no inline fluid filter for high flow applications

PerformAA™ RAC Air Assist Gun Models

High-pressure gun includes carbide seat/ball and choice of LTX or FFLP RAC SwitchTip.

Model	Maximum Working Fluid Pressure psi (MPa, bar)	Air Cap	Air Cap Assembly	Includes Fluid Swivel Connector
26B517	5000 (34.5, 345)	Reverse-a-Clean® (RAC)	26B869	
26B518	5000 (34.5, 345)	Reverse-a-Clean® (RAC)	26B869	✓



PerformAA™ Airless Gun Models

Airless gun includes carbide seat and ball, 100 mesh inline fluid filter, and choice of AXM or AXF spray tip.

Model	Maximum Working Fluid Pressure psi (MPa, bar)	Air Cap	Air Cap Part Number	Includes Fluid Swivel Connector
26B519	1500 (10.5, 105)	Airless (AL)	2AL042	
26B520	5000 (34.5, 345)	Airless (AL)	2AL042	

Warnings

The following are general warnings related to the setup, use, grounding, maintenance, and repair of this equipment. Additional, more specific warnings may be found throughout the body of this manual where applicable. Symbols that appear in the body of the manual refer to these general warnings. When these symbols appear throughout the manual, refer back to these pages for a description of the specific hazard.

 <h1 style="margin: 0;">WARNING</h1>	
	<p>FIRE AND EXPLOSION HAZARD</p> <p>Flammable fumes, such as solvent and paint fumes, in work area can ignite or explode. Paint or solvent flowing through the equipment can cause static sparking. To help prevent fire and explosion:</p> <ul style="list-style-type: none"> • Use equipment only in well-ventilated area. • Eliminate all ignition sources; such as pilot lights, cigarettes, portable electric lamps, and plastic drop cloths (potential static sparking). • Ground all equipment in the work area. See Ground the Spray Gun, instructions. • Never spray or flush solvent at high pressure. • Keep work area free of debris, including solvent, rags and gasoline. • Do not plug or unplug power cords, or turn power or light switches on or off when flammable fumes are present. • Use only grounded hoses. • Hold gun firmly to side of grounded pail when triggering into pail. Do not use pail liners unless they are anti-static or conductive. • Stop operation immediately if static sparking occurs or you feel a shock. Do not use equipment until you identify and correct the problem. • Keep a working fire extinguisher in the work area.
	<p>SKIN INJECTION HAZARD</p> <p>High-pressure fluid from gun, hose leaks, or ruptured components will pierce skin. This may look like just a cut, but it is a serious injury that can result in amputation. Get immediate surgical treatment.</p> <ul style="list-style-type: none"> • Do not spray without tip guard and trigger guard installed. • Engage trigger lock when not spraying. • Do not point gun at anyone or at any part of the body. • Do not put your hand over the spray tip. • Do not stop or deflect leaks with your hand, body, glove, or rag. • Follow the Pressure Relief Procedure, when you stop spraying and before cleaning, checking, or servicing equipment. • Tighten all fluid connections before operating the equipment. • Check hoses and couplings daily. Replace worn or damaged parts immediately.

WARNING



EQUIPMENT MISUSE HAZARD

Misuse can cause death or serious injury.



- Do not operate the unit when fatigued or under the influence of drugs or alcohol.
- Do not exceed the maximum working pressure or temperature rating of the lowest rated system component. See **Technical Specifications** in all equipment manuals.
- Use fluids and solvents that are compatible with equipment wetted parts. See **Technical Specifications** in all equipment manuals. Read fluid and solvent manufacturer's warnings. For complete information about your material, request Safety Data Sheets (SDSs) from distributor or retailer.
- Do not leave the work area while equipment is energized or under pressure.
- Turn off all equipment and follow the **Pressure Relief Procedure** when equipment is not in use.
- Check equipment daily. Repair or replace worn or damaged parts immediately with genuine manufacturer's replacement parts only.
- Do not alter or modify equipment. Alterations or modifications may void agency approvals and create safety hazards.
- Make sure all equipment is rated and approved for the environment in which you are using it.
- Use equipment only for its intended purpose. Call your distributor for information.
- Route hoses and cables away from traffic areas, sharp edges, moving parts, and hot surfaces.
- Do not kink or over bend hoses or use hoses to pull equipment.
- Keep children and animals away from work area.
- Comply with all applicable safety regulations.



TOXIC FLUID OR FUMES HAZARD

Toxic fluids or fumes can cause serious injury or death if splashed in the eyes or on skin, inhaled, or swallowed.

- Read Safety Data Sheets (SDSs) to know the specific hazards of the fluids you are using.
- Store hazardous fluid in approved containers, and dispose of it according to applicable guidelines.



PERSONAL PROTECTIVE EQUIPMENT

Wear appropriate protective equipment when in the work area to help prevent serious injury, including eye injury, hearing loss, inhalation of toxic fumes, and burns. Protective equipment includes but is not limited to:

- Protective eyewear, and hearing protection.
- Respirators, protective clothing, and gloves as recommended by the fluid and solvent manufacturer.

Spray Gun Overview

The air assist spray gun combines the airless and air spray concepts.

Airless and air assist spray:

- Hydraulic force pushes high-pressure fluid through the spray tip orifice.
- The spray tip shapes the fluid into a spray pattern. The fluid flow and pattern width depend on the size of the spray tip, the fluid viscosity, and the fluid pressure. See **Spray Tip Charts**, page 52.

Air assist spray:

- Air from the air cap further atomizes the fluid and completes the atomization of the paint tails into the pattern to produce a uniform pattern. Air caps optimize the finish quality for different coating properties. Multiple air caps are available to meet various finishing needs. See the **Air Cap Selection Guide**, page 56.
- The fan adjustment knob can adjust the width of the pattern.
- The air assist spray gun has a different pattern width adjustment procedure than an air spray gun.
- Pattern width is decreased by using more air.
- Pattern width is increased by using less air or using a larger spray tip size.

The spray gun has a built-in lead and lag operation. When triggered, the gun emits air before the fluid discharges. When the trigger releases, the fluid stops before the air flow stops. This helps ensure the spray atomizes and prevents fluid buildup on the air cap.

Component Identification

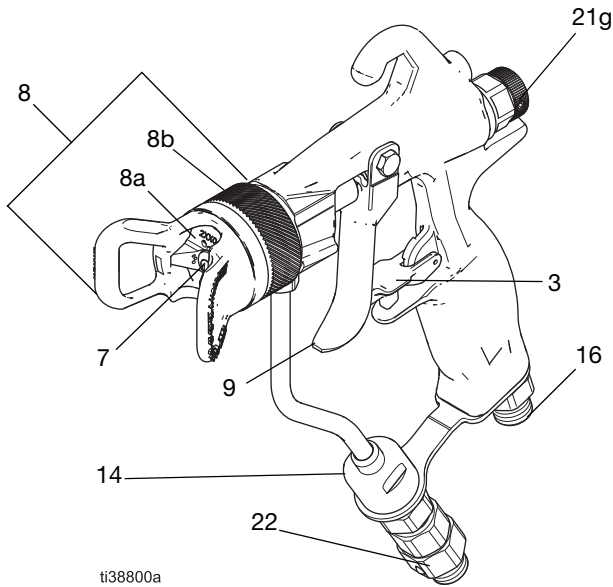

Fig. 1: PerformAA 50 with fluid swivel

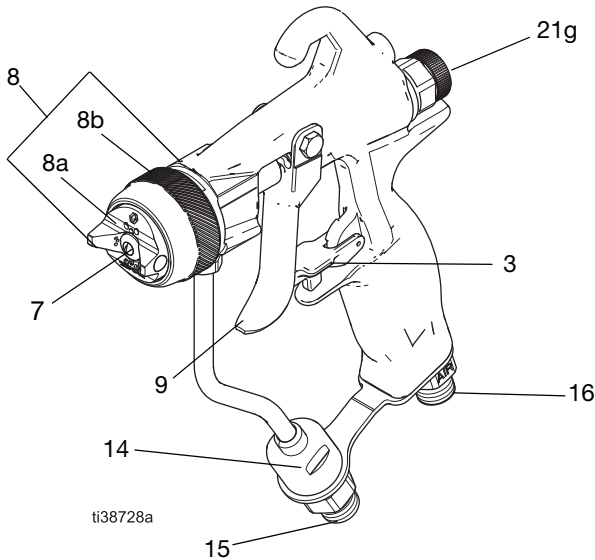

Fig. 2: PerformAA 15 without fluid swivel

Part	Purpose
Trigger Lock (3)	Locks the trigger (9) to prevent the gun from spraying.
Spray Tip (7)	Atomizes the fluid and shapes the pattern width. See Spray Tip Charts , page 52.
Air Cap Assembly (8)	Assembled air cap: air cap (8a), retaining ring (8b), tip guard, and seals.
Air Cap (8a)	Holds the spray tip (7) and completes the atomization of the paint tails. See Air Cap Selection Guide , page 56.
Retaining Ring (8b)	Attaches the air cap assembly to the gun. High pressure gun retaining rings include a tip guard to keep body parts away from the spray tip.
Trigger (9)	Activates the spray gun.
Inline Fluid Filter (14)	Provides final fluid filtration.
Fluid Inlet Fitting (15)	1/4-18 npsm for fluid supply hose.
Gun Air Inlet (16)	1/4-18 npsm (R 1/4-19) inlet for the gun air supply hose. Compatible with npsm and bsp female swivel connectors.
Fan Adjustment Knob (21g)	Adjusts fan pattern shape and width.
Fluid Swivel Connector (22)	Improves gun maneuverability. Included with select models. See Models , page 3.

Typical Installation

NOTE: The typical installation shown in FIG. 3 is only a guide for selecting and installing air assist spray systems. Contact your Graco distributor for assistance in designing a system to meet your needs.

Key:

- A Air Shutoff Valve
- B Air Line Filter
- C Gun Air Pressure Regulator
- D Bleed Type Master Air Valve

- E Pump Air Pressure Regulator
- F Air Assist Spray Gun
- G Gun Fluid Supply Hose
- H Gun Air Supply Hose
- I Fluid Filter
- J Grounding Wire
- K Suction Hose
- L Fluid Drain Valve
- M Paint Supply Pail
- N Air Line

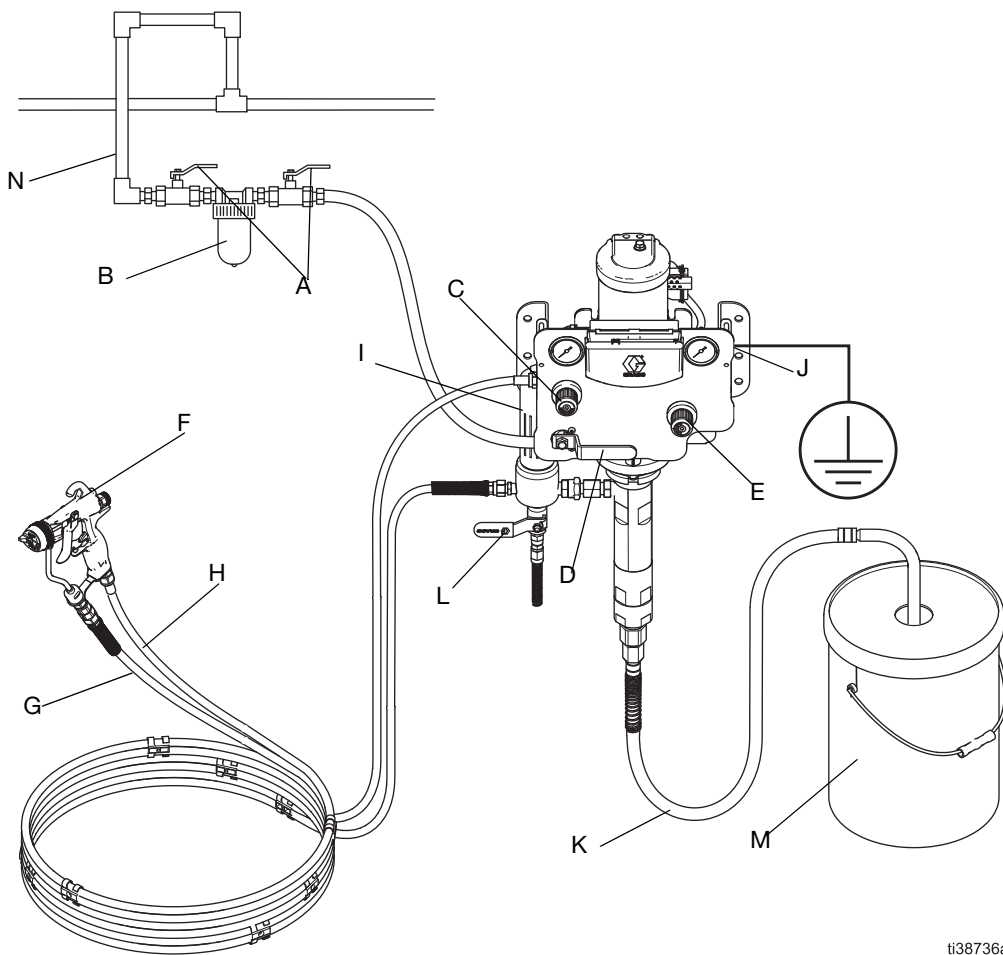

ti38736a

FIG. 3: Typical installation (PerformAA 15 model 26B501 shown)

Typical Installation Accessories

Install the accessories shown in FIG. 3, using adapters as necessary.

Air Line Accessories

- Bleed-type master air valve (D): required in your system to relieve air trapped between the pump and the gun when the valve is closed.

NOTE: Be sure the valve is easily accessible from the pump and located downstream from the air regulator.

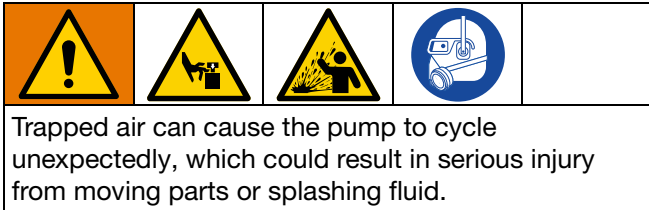

- Pump air pressure regulator (E): to control pump speed and fluid outlet pressure. Locate it close to the pump.
- Air line filter (B): removes harmful dirt and moisture from compressed air supply. Ensures a dry, clean air supply.
- Gun air supply hose (H): connects air supply to the gun. Use a 3/16 in. (5 mm) I.D. or larger air hose to minimize excessive pressure drop in the hose.
- Gun air pressure regulator (C): controls air pressure to the gun.
- Air shutoff valve (A): shuts off air to the gun and pump.

Fluid Line Accessories

- Fluid filter (I): with a 60 or 100 mesh (250 micron) stainless steel element to filter particles from the fluid as it leaves the pump. Always use a clean fluid filter.
- Fluid drain valve (L): relieves fluid pressure in the hose and gun
- Fluid shutoff valve (not shown): shuts off fluid flow. Can be installed in the fluid line to the gun.
- Fluid pressure regulator (not shown): for more precise adjustment of the fluid pressure. Can be installed in the fluid line to the gun.

NOTE: Systems without a fluid regulator control the fluid pressure with the pump air regulator, per the formula:

$$\text{Pump Ratio} \times \text{Pump Air Regulator Setting} = \text{Fluid Pressure}$$

- Gun fluid supply hose (G): supplies fluid from a pump to the spray gun.
- Fluid swivel connector (22): for easier gun movement. Some models include a swivel connector. See **Models**, page 3.

Setup

Ventilate the Spray Booth

--	--	--	--	--

Do not operate the gun unless ventilating air flow is above the minimum required value. Provide fresh air ventilation to avoid the buildup of flammable or toxic vapors when spraying, flushing, or cleaning the gun. Interlock the gun fluid supply to prevent operation unless ventilating air flow is above the minimum required value.

The spray booth must have a ventilation system.

Electrically interlock the gun fluid supply with the ventilators to prevent gun operation any time that the ventilation air flow falls below minimum values. Check and follow all local codes and regulations regarding air exhaust velocity requirements. Verify the operation of the interlock at least once a year.

Ground the Spray Gun

--	--	--	--	--

The equipment must be grounded to reduce the risk of static sparking. Static sparking can cause fumes to ignite or explode. Grounding provides an escape wire for the electric current.

Ground the spray gun through connection to a properly grounded fluid supply hose and pump. Check your local electrical code and pump manual for detailed grounding instructions. Use only electrically conductive fluid hoses.

Connect the Spray Gun

Air assist models: Follow all steps in the Connect the Spray Gun procedure.

Airless models: Follow the Connect the Spray Gun procedure beginning with step 3.

1. Connect the gun air supply hose (H) to the gun air inlet (16). See FIG. 4.

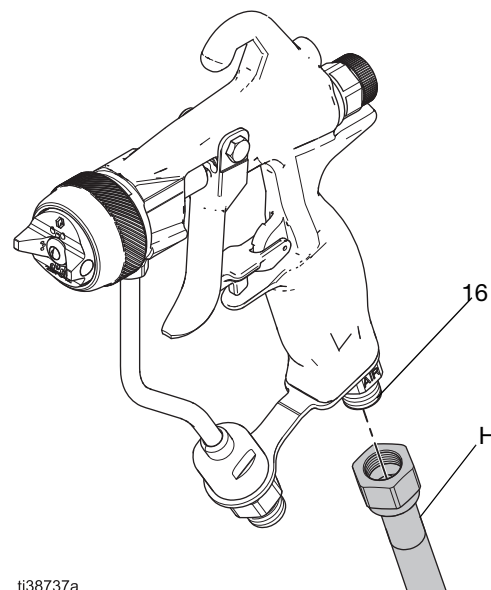

ti38737a

FIG. 4: Connect air hose to gun

2. Connect the other end of the gun air supply hose (H) to the gun air pressure regulator (C) or the air shutoff valve (A) outlet. See FIG. 5.

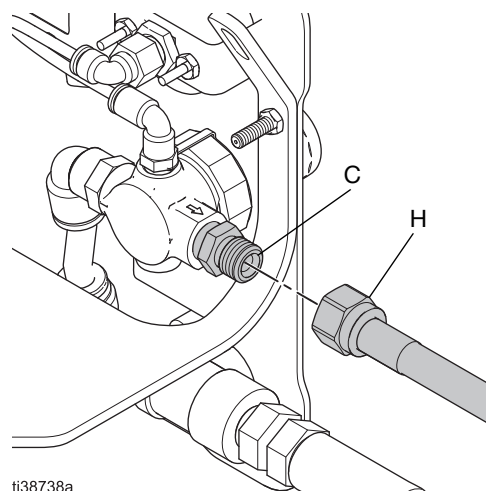

ti38738a

FIG. 5: Connect air hose to gun air pressure regulator

NOTE: Blow air through the gun fluid supply hose (G) and flush it with a compatible solvent before connecting to the gun.

Setup

3. Connect the gun fluid supply hose (G) to the fluid inlet fitting (15) or the fluid swivel connector (22). See FIG. 6.

NOTE: Purchase a fluid swivel connector (22) separately with Kit 189018.

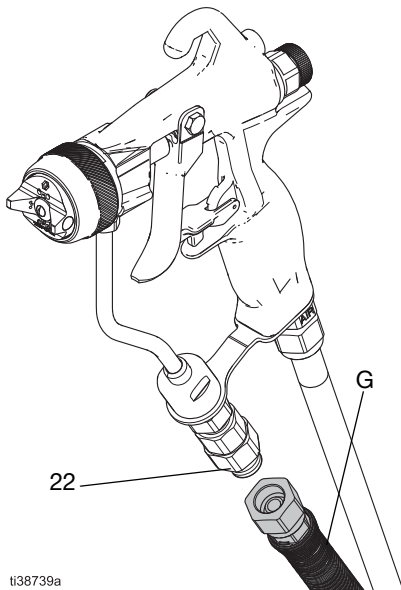
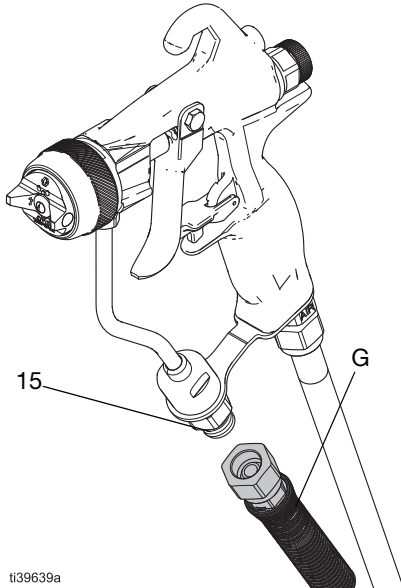

FIG. 6: Connect the gun fluid supply hose

4. Connect the other end of the gun fluid supply hose (G) to the pump fluid outlet.

Flush Before Using

The equipment was tested with lightweight oil, which is left in the fluid passages to protect parts. To avoid contaminating your fluid with oil, flush the equipment with a compatible solvent before using the equipment. See **Flushing Procedure**, page 21.

Follow the **Pressure Relief Procedure**, page 15.

Spray Tip and Air Cap Setup

				
<p>To avoid serious injury from skin injection, do not put your hand in front of the spray tip when installing or removing the spray tip and air cap assembly.</p>				

See **Reverse-A-Clean® (RAC) Setup**, page 14 to complete RAC spray gun setup.

1. Follow the **Pressure Relief Procedure**, page 15.
2. Engage the trigger lock (3). See FIG. 12, page 15.
3. Remove the air cap assembly (8) and spray tip (7).

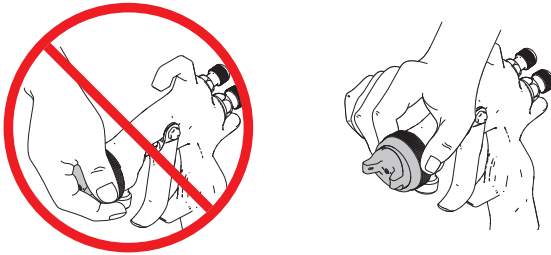

4. Install the spray tip (7) in the air cap (8a) with the tip locating tab positioned in the air cap slot. See FIG. 7.

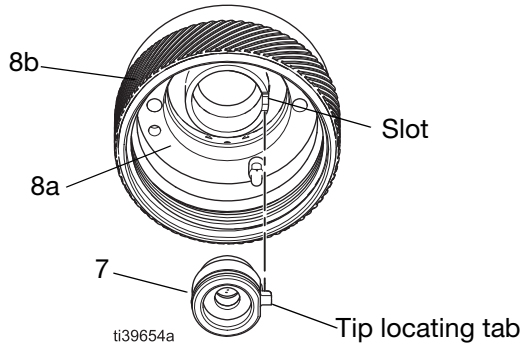

FIG. 7: Spray tip and air cap setup (back view)

5. Install the air cap assembly (8) to the spray gun.

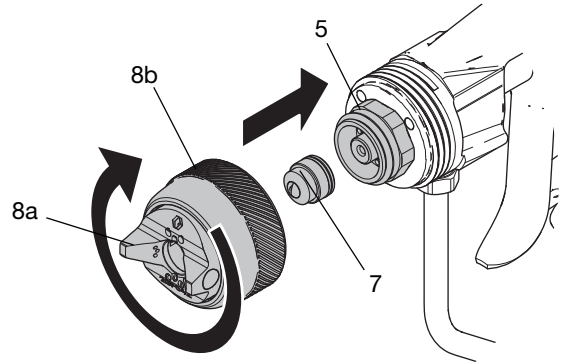

FIG. 8: Air cap and retaining ring installation

6. Rotate the air cap (8a) to the horizontal or vertical spray pattern position. See FIG. 9.

NOTE: PerformAA 15 models can be positioned precisely with an air cap alignment pin (8e). See **Alignment Pin Adjustment**, page 14.

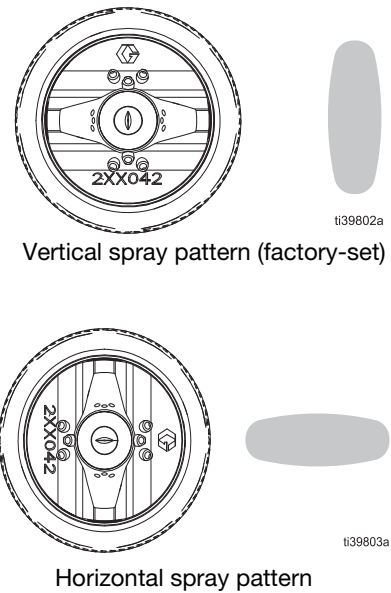

FIG. 9: Spray pattern positions

7. Tighten the retaining ring (8b) firmly by hand to ensure a proper seal between the spray tip (7) the fluid cartridge (5).

Alignment Pin Adjustment

The air cap alignment pin (8e) is factory-set to the vertical spray pattern position. See FIG. 9

1. Unscrew the air cap alignment pin (8e) with needle nose pliers.
2. Move the alignment pin (8e) to the desired position. See FIG. 10.

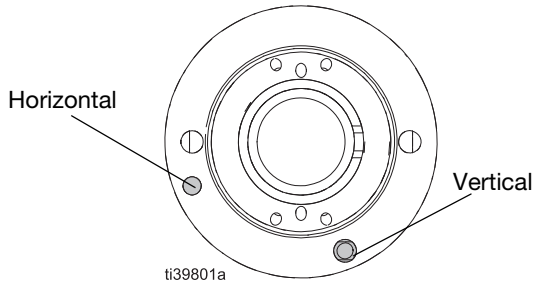

FIG. 10: Air cap alignment pin positions

3. Use low-strength thread sealant to reinstall.
4. Torque to 1.5-2.5 in-lb (0.2-0.3 N•m). **Do not over tighten.**

Reverse-A-Clean® (RAC) Setup

Convert any air assist or airless PerformAA 50 gun models to a RAC gun model with RAC Conversion Kit 26B722. See **Reverse-a-Clean Kits**, page 59.

1. Follow the **Pressure Relief Procedure**, page 15.
2. Engage the trigger lock (3). See FIG. 12, page 15.
3. Insert the RAC housing into the air cap assembly.

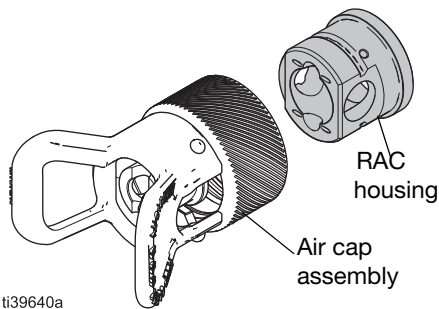

4. Insert the tip gasket.

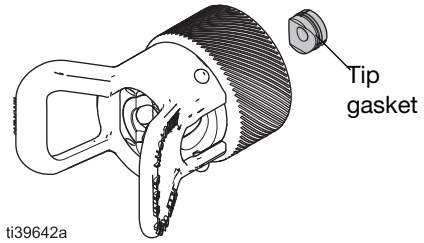

5. Insert the RAC SwitchTip.

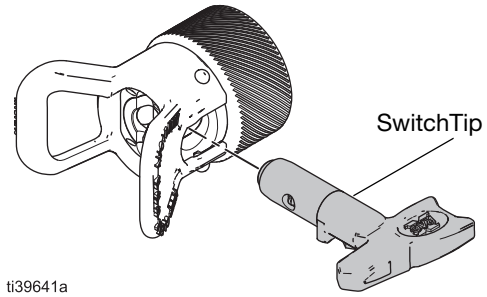

6. Screw the air cap assembly onto the gun, and tighten firmly by hand.

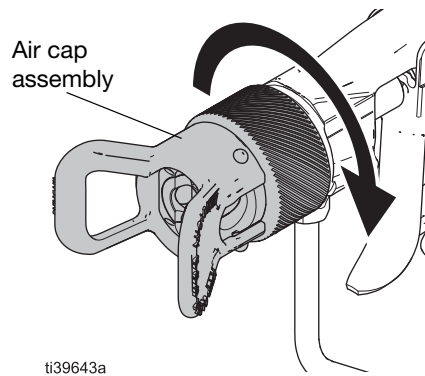







Operation

Be sure to read and follow the **Warnings** starting on page 5 and throughout the body of this instruction manual.

Keep the wallet sized warning card (222385), provided with the gun, with the operator of this equipment at all times. The card contains important treatment information should a skin injection injury occur.

Pressure Relief Procedure

 Follow the Pressure Relief Procedure whenever you see this symbol.

				
<p>This equipment stays pressurized until pressure is manually relieved. To help prevent serious injury from pressurized fluid, such as skin injection and splashing fluid, follow the Pressure Relief Procedure when you stop spraying and before cleaning, checking, or servicing the equipment.</p>				

1. Engage the trigger lock (3). See FIG. 12.
2. Shut off the pump. See your pump manual.
3. Shut off the gun air supply.
4. Disengage the trigger lock (3). See FIG. 12.
5. Hold a metal part of the gun firmly to a grounded metal pail. Trigger the gun to relieve pressure. See FIG. 11.

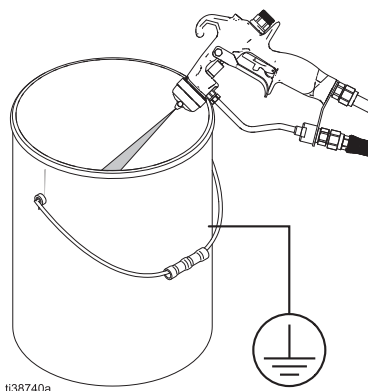

FIG. 11: Relieve gun pressure

Optional: Open all fluid drain valves in the system with a waste container ready to catch drainage.

6. Engage the trigger lock (3). See FIG. 12.
7. If you suspect the spray tip (7) or gun fluid supply hose (G) is clogged or that pressure has not been fully relieved:
 - a. VERY SLOWLY loosen the retaining ring (8b) or the hose end coupling (22) to relieve pressure gradually.
 - b. Loosen the nut or the coupling (22) completely.
 - c. Clear the obstruction in the hose or tip.

NOTE: Close any open fluid drain valves before operating the spray gun.

Trigger Lock

Always engage the trigger lock (3) when you stop spraying to prevent the gun from being triggered accidentally by hand or if dropped or bumped.

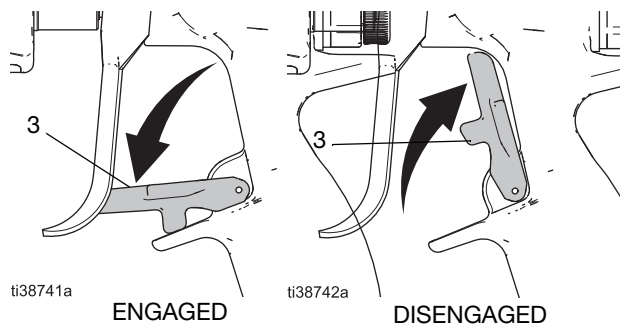



FIG. 12: Trigger lock positions

Spray Gun Operation

				
<p>To reduce the risk of component rupture and serious injury, including injection, do not exceed the maximum working pressure of the gun. Do not exceed the maximum working pressure of the lowest rated system component.</p>				

PerformAA 15 and PerformAA 50 Air Assist

Follow the **Spray Gun Operation Procedure**.

PerformAA RAC

Follow steps 1-4, and steps 6-8 of the **Spray Gun Operation Procedure**. Adjust pattern width with a different spray tip. See **Spray Tip Charts**, page 52.

PerformAA Airless

Follow steps 1-4 of the **Spray Gun Operation Procedure**. Adjust pattern width with a different spray tip. See **Spray Tip Charts**, page 52.

Spray Gun Operation Procedure

1. Start with the air pressure off.

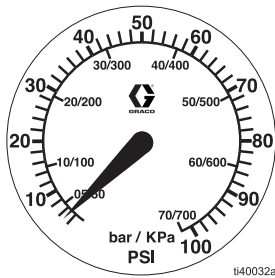

FIG. 13: Air pressure off

2. Set the fluid pressure at a low starting pressure.

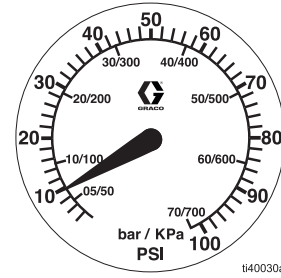

FIG. 14: Low starting pressure

3. Trigger the gun to check the atomization; do not adjust the pattern shape yet.

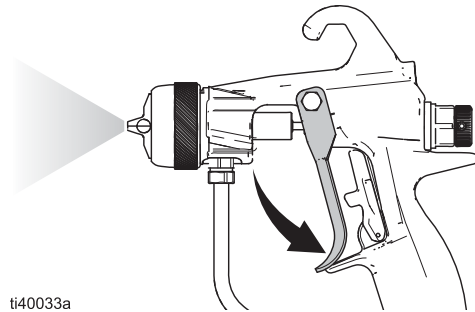

FIG. 15: Check atomization

4. Slowly increase the fluid pressure until the gun sprays at the desired atomization level.

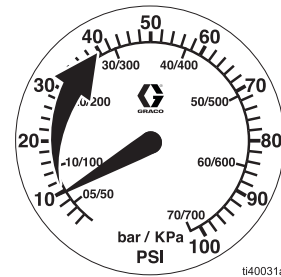

FIG. 16: Increase fluid pressure

- Turn the fan adjustment knob (21g) clockwise until completely closed.

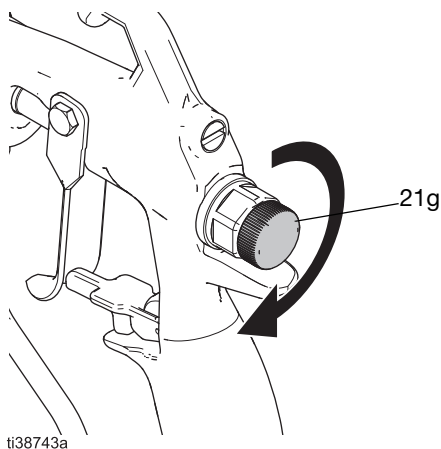

FIG. 17: Close the fan adjustment knob

- Set the atomizing air pressure to approximately 5 psi (34 kPa, 0.34 bar) when triggered.

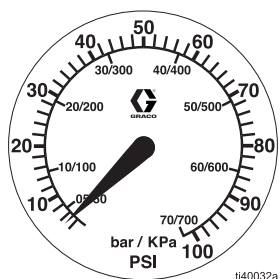

FIG. 18: Set atomizing air pressure

- Spray the gun to check the spray pattern.

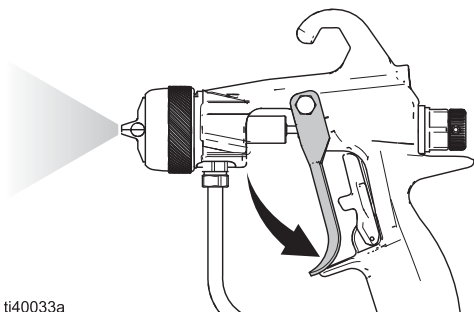

FIG. 19: Check spray pattern

- Slowly increase the inlet air pressure until the tails are completely atomized and pulled into the spray pattern. See FIG. 20.

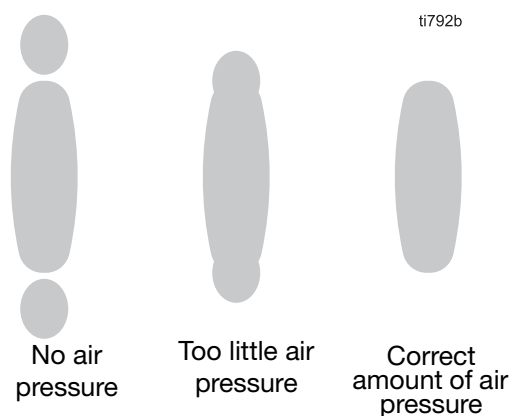

FIG. 20: Atomizing tails

NOTE: Most spray material, especially low viscosity materials, typically atomize at 7 to 10 psi (48 to 69 kPa, 0.48 to 0.7 bar). Setting the air pressure too high causes material build-up on the air cap and decreases spray efficiency.

- Adjust the pattern width if desired.

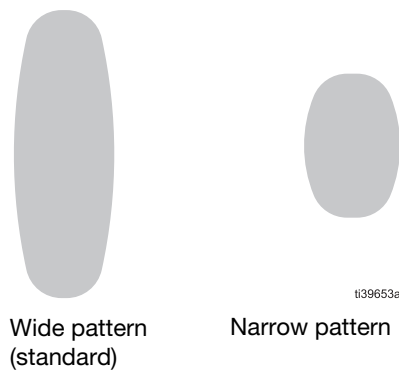

FIG. 21: Spray pattern widths

Narrow Pattern

Turn the fan adjustment knob (21g) counterclockwise (open). See FIG. 22.

If the pattern is still not narrow enough, then increase the air pressure to the gun slightly or use a different tip size. See **Spray Tip Charts**, page 52.

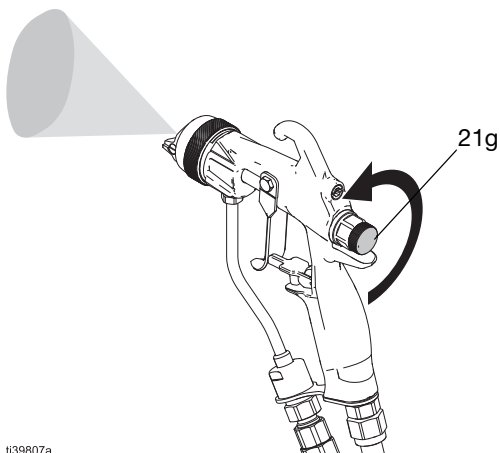

FIG. 22: Narrow pattern width

Wide Pattern

Turn the fan adjustment knob (21g) clockwise (close). FIG. 23.

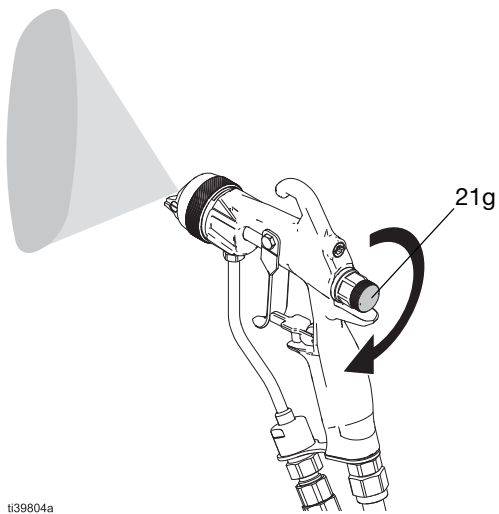

FIG. 23: Wide pattern width

Spray Finishing Application

1. Maintain a distance of approximately 8 to 12 in. (200 to 300 mm) from the object being sprayed.
2. Hold the gun perpendicular to the surface.
3. Engage the trigger (9).
4. Spray smooth, even, and parallel strokes. Overlap each stroke by 50% for even coverage. **Do not arc the strokes.** Arcing causes uneven coverage. See FIG. 24.

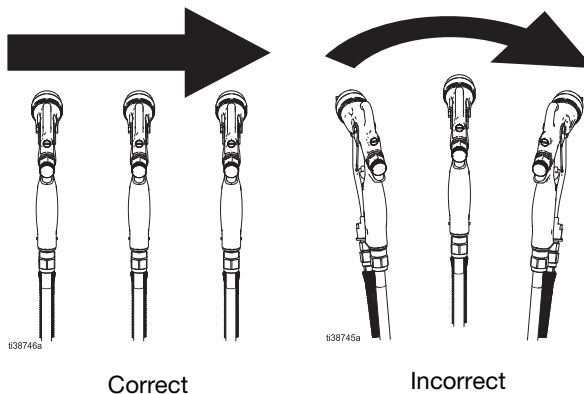

FIG. 24: Spray techniques

NOTE: This spray gun applies all coatings evenly without cross coating.

HVLP Verification

Many air quality authorities accept air assist spraying as an efficient process and in compliance with environmental regulation.

To comply with HVLP requirements, the air pressure at the air cap must be less than 10 psi (.7 bar, 07 MPa). Use an HVLP Verification Kit to verify the air cap air pressure. See the **Air Cap Selection Guide**, page 56. HVLP Verification Kits are for testing only. Do not use for actual spray application.

Maintenance

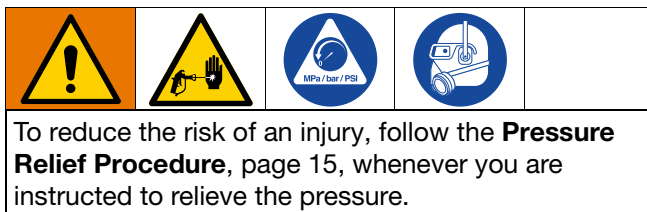

Daily Gun Care

1. Follow the **Pressure Relief Procedure**, page 15.

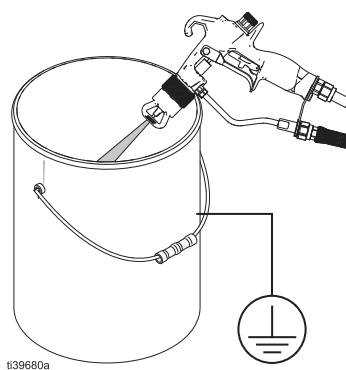

FIG. 25: Relieve the pressure

2. Remove the air cap assembly (8) and spray tip (7).

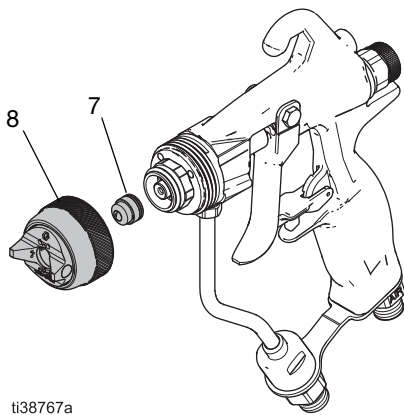

FIG. 26: Remove the air cap assembly and spray tip

3. Flush the gun with a compatible solvent. Follow the **Flushing Procedure**, page 21.

NOTICE

Methylene chloride with formic or propionic acid will damage aluminum and nylon components. Do not use to flush or clean the gun.

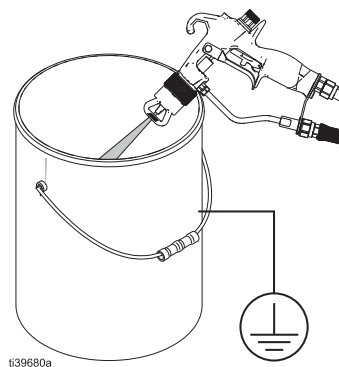

FIG. 27: Flush the gun

4. Soak the spray tip (7) in a compatible solvent.

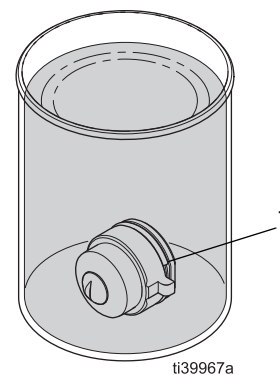

FIG. 28: Soak the spray tip

5. Clean the air cap (8a), spray tip (7), and the outside of the fluid cartridge (6) with a soft-bristle brush. See **Cleaning Procedure**, page 22.

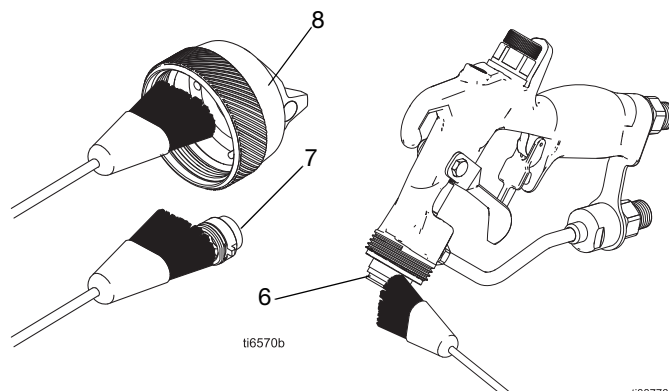
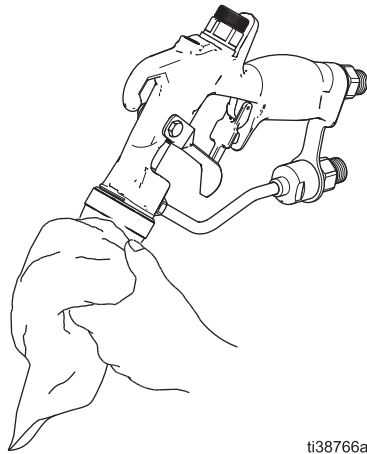

FIG. 29: Clean parts with a soft-bristle brush

NOTE: Always point the gun down during cleaning to prevent solvent entering the gun air passages. Solvent left in gun air passages could result in a poor quality paint finish.

- Clean the outside of the gun with a soft cloth.



ti38766a

FIG. 30: Clean the outside of the gun

- Clean or replace the inline fluid filter (14). See **Inline Fluid Filter Cleaning Procedure**.

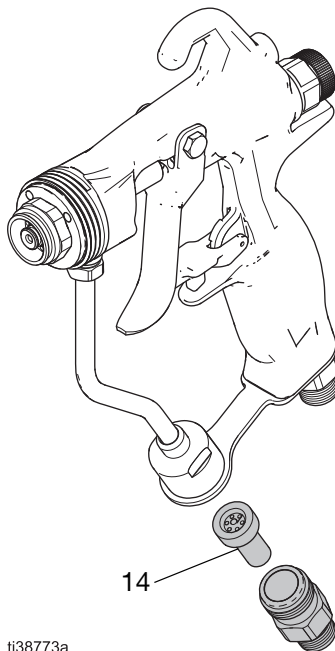

ti38773a

FIG. 31: Check the inline fluid filter

- Check the trigger (9) and the fan adjustment knob (21g) movement. Lubricate or repair if necessary. See FIG. 32.

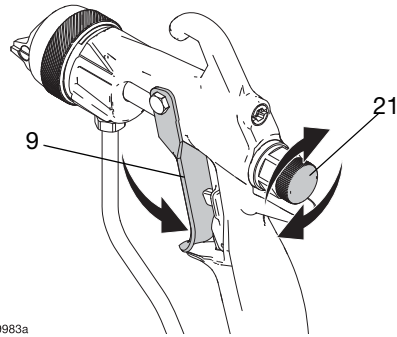

ti39983a

FIG. 32: Check the trigger and fan adjustment knob

- Check fluid hoses for leakage. Tighten fittings or replace equipment as needed.

NOTE: Do not use any cleaning method that allows solvent into the gun air passages. Solvent left in gun air passages could result in a poor quality paint finish.



ti38755a

ti22387a

ti38747a

ti38758a

- Do not point gun up while cleaning.
- Do not wipe the gun with a cloth soaked in solvent; wring out the excess.
- Do not immerse the gun in solvent.
- Do not use metal tools to clean the air cap holes; this may scratch them. Scratches may distort the spray pattern.

Flushing Procedure

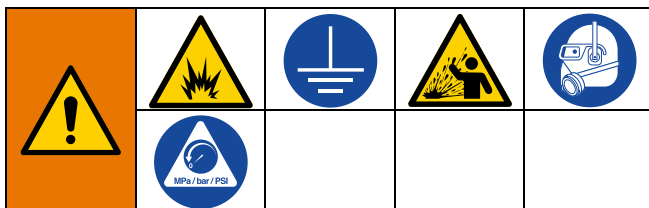

To avoid fire and explosion, always ground equipment and waste container. To avoid static sparking and injury from splashing fluid, always flush at the lowest possible pressure.

- Flush before changing colors, before fluid can dry in the equipment, at the end of the day, before storing, and before repairing equipment.
- Flush at the lowest pressure possible. Check connectors for leaks and tighten as necessary.
- Flush with a fluid that is compatible with the fluid being dispensed and the equipment wetted parts.

1. Follow the **Pressure Relief Procedure**, page 15.
2. Remove the retaining ring (8b), air cap (8a), and spray tip (7).
3. Shut off the air supply.

Optional: Disconnect the air supply hose (H) from the gun.

4. Change the fluid source to solvent or disconnect the fluid line and connect a solvent supply line to the gun.

NOTICE

Methylene chloride with formic or propionic acid will damage aluminum and nylon components. Do not use to flush or clean the gun.

5. Point the gun down into a grounded metal container. Hold a metal part of the gun firmly to the grounded metal container.
6. Increase the fluid pressure slowly.

7. Flush until clean solvent flows from the gun.

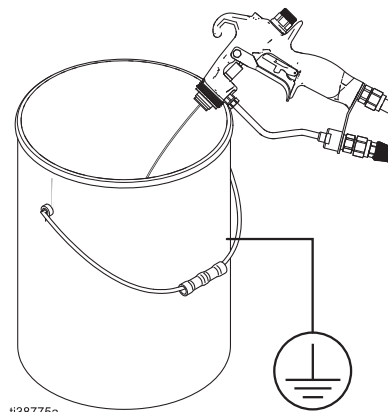

FIG. 33: Flush gun into metal container

8. Turn off the solvent supply.
9. Follow the **Pressure Relief Procedure**, page 15.

Inline Fluid Filter Cleaning Procedure

1. Unscrew the fluid inlet fitting (15).
2. Remove the inline fluid filter (14) from the fluid tube assembly (13).
3. Clean or replace.
4. Install the fluid inlet fitting (15). Torque to 175-185 in-lb (20-21 N•m).

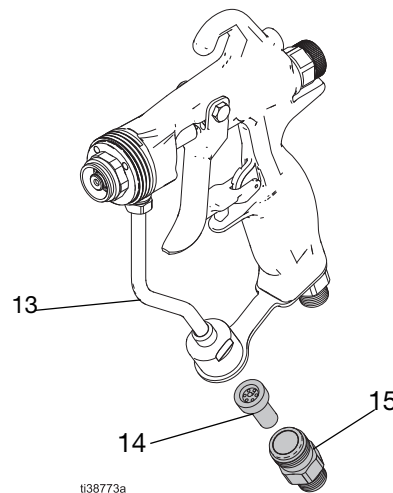
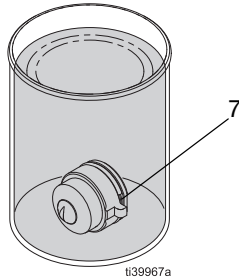

FIG. 34: Clean the inline fluid filter

Cleaning Procedure

1. Follow the **Pressure Relief Procedure**, page 15.
2. Remove the air cap assembly (8) and spray tip (7).
3. Flush the gun with a compatible solvent. See **Flushing Procedure**, page 21.
4. Soak the spray tip (7) in a compatible solvent.



t139967a

FIG. 35: Soak the spray tip

5. Dip the end of a soft-bristle brush into a compatible solvent.

NOTE: Do not continuously soak the brush's bristles in the solvent.

NOTICE

Do not use metal tools to clean the air cap assembly parts. Metal tools may scratch the air cap and cause spray pattern distortion.

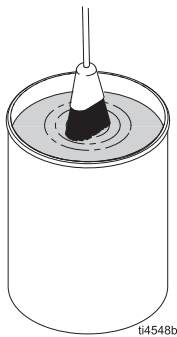

t14548b

FIG. 36: Dip brush into solvent

6. Clean the air cap assembly (8) and spray tip (7)

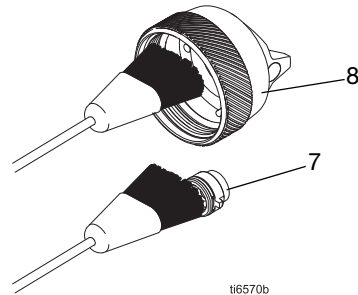

t16570b

FIG. 37: Clean the air cap assembly and spray tip

- a. Clean the parts with a soft-bristle brush.
 - b. Use a soft tool, such as an unclogging needle or toothpick, to clean the air cap (8a) holes.
 - c. Blow air through the spray tip (7) to clear the orifice.
7. Point the gun down and clean the outside of the diffuser (6) with a soft-bristle brush and compatible solvent.

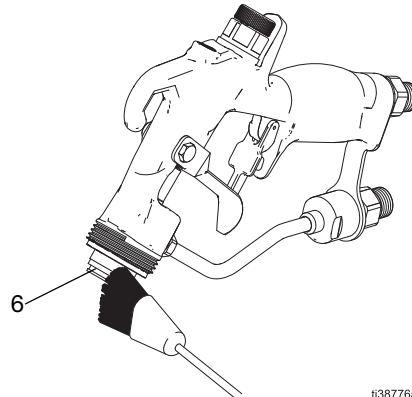

t138776a

FIG. 38: Clean the outside of the diffuser

8. Point the gun down and clean the outside of the gun with a soft cloth and compatible solvent.

NOTE: Do not immerse the gun in solvent.



ti38766a

FIG. 39: Clean the outside of gun

9. Clean the fluid cartridge (6) if necessary.
 - a. Follow the **Remove Fluid Cartridge Procedure**, page 34 to remove the fluid cartridge (6).

NOTICE

Always trigger the gun to remove or tighten the fluid cartridge to prevent seat damage.

- b. Clean with a soft-bristle brush and compatible solvent.
 - c. Follow the **Install Fluid Cartridge Procedure**, page 35. Torque to 175-185 in-lb (20-21 N•m).
10. Reassemble and install the spray tip (7) and air cap assembly (8). See **Spray Tip and Air Cap Setup**, page 13.

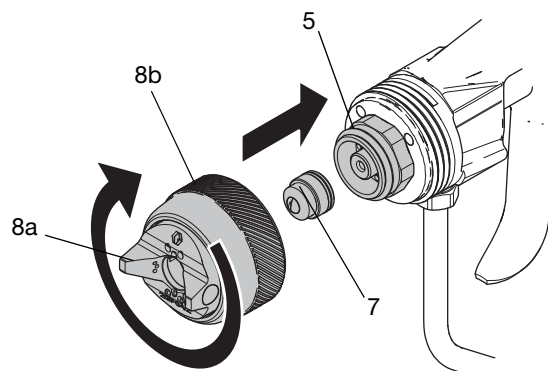

ti39674a

FIG. 40: Reassemble the spray tip and air cap

11. Clean the inline fluid filter. See **Inline Fluid Filter Cleaning Procedure**, page 21.
12. Check the trigger (9) and the fan adjustment (21g) movement.
13. Lubricate the trigger contact points: the pivot pin (10), pivot nut (11), needle shaft, and washer. See **Install the Trigger**, page 30.

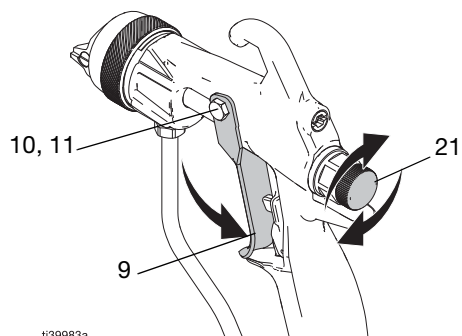

ti39983a

FIG. 41: Check the trigger and fan adjustment knob

Reverse-A-Clean (RAC) Tip Maintenance

				
<p>To avoid serious injury from skin injection, do not put your hand in front of the spray tip when removing, installing, or maintaining the air cap assembly.</p>				

NOTE: Do not soak the RAC tip seat gasket (33a) in solvent for extended periods of time or swelling may occur.

Clear a clogged RAC tip

1. Release the trigger, and engage the trigger lock (3).

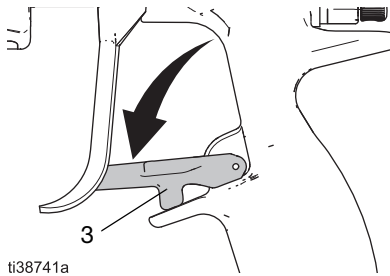

2. Rotate the SwitchTip and tighten the retaining ring.

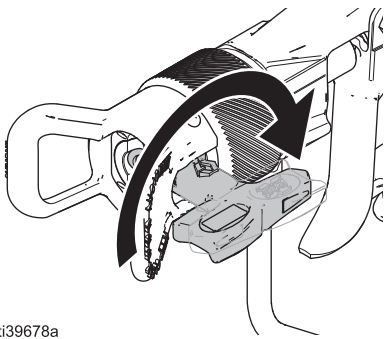

3. Disengage the trigger lock (3).

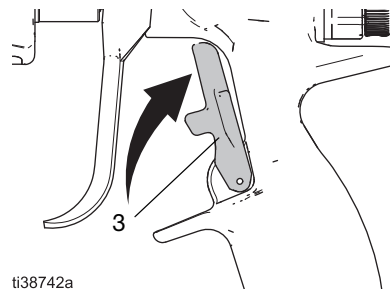

4. Trigger the gun into a pail to clear the clog.

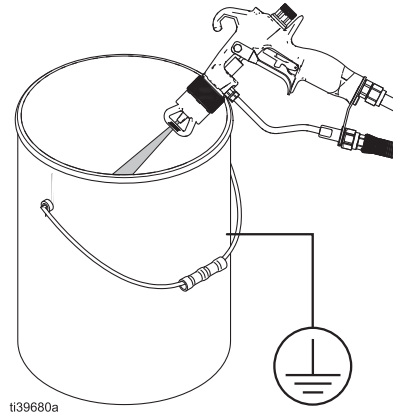

5. Engage the trigger lock (3)

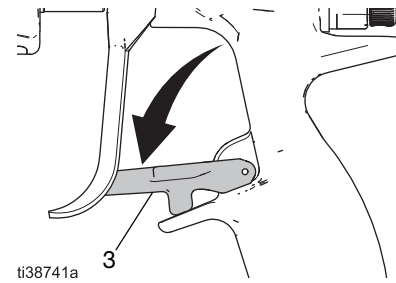



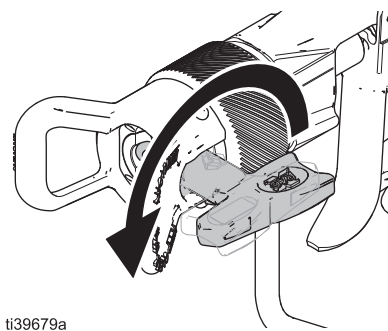

6. Rotate the SwitchTip to its original position. Tighten the retaining ring.

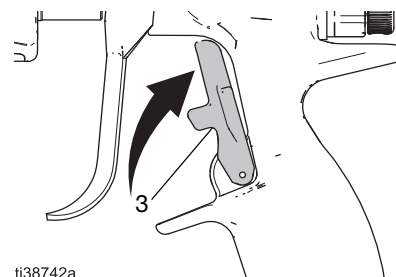

7. Disengage the trigger lock (3), and continue spraying.



Troubleshooting



				
<p>To reduce the risk of a skin injection injury, always follow the Pressure Relief Procedure, page 15, whenever instructed to relieve the pressure. To avoid serious injury from skin injection, do not put your hand in front of the spray tip when installing or removing the air cap assembly and spray tip.</p>				

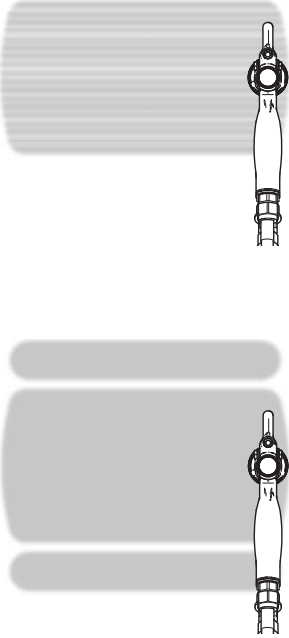
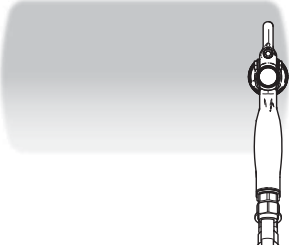

Follow **Pressure Relief Procedure**, page 15, before checking or repairing the gun.

NOTE: Check all possible problems and causes before disassembling the air cap assembly and spray tip. Air and fluid imbalance may cause improper air patterns.

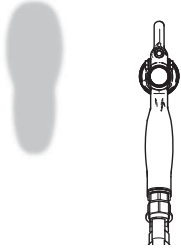
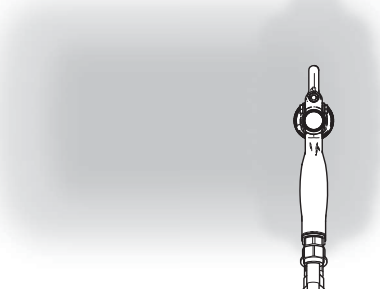
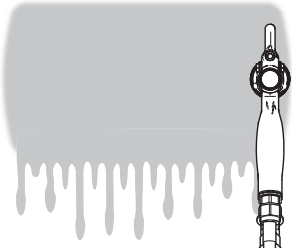
Spray Pattern Troubleshooting

Problem	Possible Causes	Solutions	Why it is important
<p>Tails and streaks in pattern</p> 	<ul style="list-style-type: none"> Tails not fully atomized Tip worn Tip plugged Fluid pressure too low 	<ul style="list-style-type: none"> Clean tip Check tip wear/ flow rate Increase fluid pressure Decrease tip orifice size 	<ul style="list-style-type: none"> Even and blended finish Even paint thickness and coverage Maintains transfer efficiency Decreases dry spray Increases cleanliness of tip, air cap, and gun
<p>Uneven spray pattern</p> 	<ul style="list-style-type: none"> Dirty or plugged air cap holes Tip worn Tip plugged Operator spray technique 	<ul style="list-style-type: none"> Clean air cap Clean tip Check tip for wear/flow rate Review operator technique 	<ul style="list-style-type: none"> Even and blended finish Eliminates stripes Even paint thickness and coverage

Problem	Possible Causes	Solutions	Why it is important
<p>Irregular pattern</p> 	<ul style="list-style-type: none"> • Spray tip partially plugged • Dirty or plugged air cap holes 	<ul style="list-style-type: none"> • Clean or replace tip • Clean or replace air cap • Test different types of air caps 	<ul style="list-style-type: none"> • Even and blended finish • Even 50% overlaps • Even paint thickness and coverage
<p>Fogging, overspray, or dry spray</p> 	<ul style="list-style-type: none"> • Too much atomization air • Too high of fluid pressure • Incorrect tip size 	<ul style="list-style-type: none"> • Reduce air pressure • Decrease fluid pressure • Increase tip orifice size 	<ul style="list-style-type: none"> • Increase transfer efficiency • Decrease overspray • Improves spray booth cleanliness
<p>Paint runs or Paint Coverage Thickness</p> 	<ul style="list-style-type: none"> • Too much fluid flow • Tip worn • Incorrect tip size • Operator spray technique 	<ul style="list-style-type: none"> • Check tip wear and flow rate • Decrease tip orifice size • Review operator technique 	<ul style="list-style-type: none"> • Minimizes runs • Maintains transfer efficiency • Even paint thickness and coverage • Even 50% overlaps
<p>Rough finish or specking</p> 	<ul style="list-style-type: none"> • Too much atomization air • Too much fan pattern adjustment • Too much distance between gun and part 	<ul style="list-style-type: none"> • Decrease air pressure • Decrease tip pattern size • Adjust gun to part distance 	<ul style="list-style-type: none"> • Increases wetness of the paint on the part • Allows material to flow evenly • Even / blended finish

Problem	Possible Causes	Solutions	Why it is important
<p>Entrained Air/ Sugary Finish/ Champagne Finish</p> 	<ul style="list-style-type: none"> • Too much atomization air • Over agitation of paint supply 	<ul style="list-style-type: none"> • Decrease air pressure • Test different type of air cap • Reduce agitation of paint supply 	<ul style="list-style-type: none"> • Air caps are designed to deliver • the proper amount of air to specific materials • Improves finish appearance • Eliminates air bubbles in material
<p>Orange Peel</p> 	<ul style="list-style-type: none"> • Paint coverage too thick • Too much atomization air 	<ul style="list-style-type: none"> • Decrease fluid pressure • Test different type of air cap • Decrease tip orifice size • Decrease air pressure 	<ul style="list-style-type: none"> • Even / blended finish • Improves finish appearance • Air caps are designed to deliver the proper amount of air to specific materials

Air Leak Troubleshooting

Follow **Pressure Relief Procedure**, page 15, before checking or repairing the gun.

NOTE: Check all possible problems and causes before disassembling the air cap assembly and spray tip. Air and fluid imbalance may cause improper air patterns.

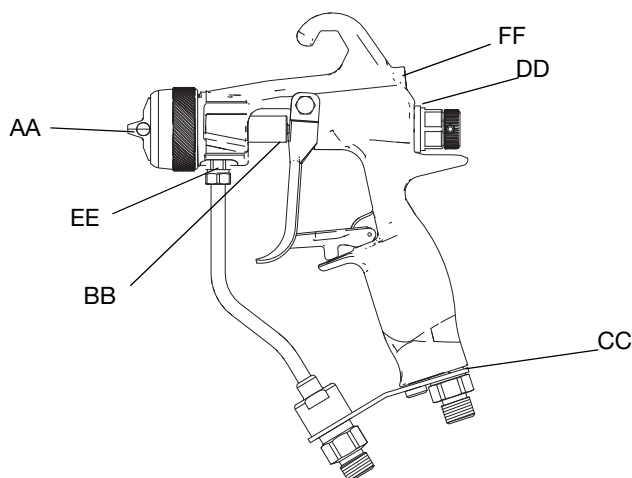

Fig. 42 Air leak identification

Leak Location		Cause	Solution	Procedure References
AA	Air cap (when the gun is not triggered)	Air valve o-ring is damaged, worn, missing, or dirty	Clean the o-ring	Air Cartridge Repair , page 32
			Clean air cartridge housing	FIG. 43 on page 30
			Replace entire air valve assembly	Air Cartridge Replacement Procedure , page 30
		U-cup seal is damaged, worn, missing, or dirty	Clean u-cup	FIG. 47 on page 31
			Replace entire air valve assembly	Air Valve Replacement , page 33
			Clean u-cup sealing surface of gun handle	Cleaning Procedure , page 22. FIG. 44 on page 30
		Air cap assembly needs repair or maintenance	Tighten retaining ring	Spray Tip and Air Cap Setup , page 13
Replace the spray tip				
Replace the spray tip gasket	Spray Tip Gasket Replacement , page 39			
BB	Gun trigger	U-cup is damaged, worn, missing, or dirty	Clean handle around u-cup seal seat.	Cleaning Procedure , page 22.
			Replace u-cup	U-Cup Replacement Procedure , page 31
CC	Gun air inlet	Air inlet fitting is not fully torqued	Torque to 175-185 in-lb (20-21 N•m)	FIG. 53, page 36
DD	Fan adjustment knob	Air cartridge is not fully torqued	Torque to 220-230 in-lb (24-25 N•m)	FIG. 43, page 30
EE	Fluid tube (near the air cap)	Damaged or worn thread tape	Re-apply thread tape to fluid cartridge	Fluid Cartridge Repair , page 35 FIG. 53
FF	Fan tube	Damaged, worn, missing, or dirty fan plug o-ring	Replace or clean fan plug o-ring and fan tube plug	Fan Tube Replacement , page 34

Fluid Troubleshooting

Follow **Pressure Relief Procedure**, page 15, before checking or repairing the gun.

NOTE: Check all possible problems and causes before disassembling the air cap assembly and spray tip. Air and fluid imbalance may cause improper air patterns.

Problem	Cause	Solution
Fluid leakage from the back of fluid packing area	Worn packings or needle shaft	Replace the fluid cartridge. See Fluid Cartridge Replacement , page 34.
		Repair the fluid cartridge packings. See Fluid Cartridge Repair , page 35.
Fluid leakage from front of gun	Needle ball dirty, worn, or damaged	Replace the needle assembly. See Fluid Cartridge Replacement , page 34.
		Repair the fluid cartridge. See Fluid Cartridge Repair , page 35.
	Worn seat	Replace the fluid cartridge. See Fluid Cartridge Replacement , page 34.
		Replace the seat and seat gasket. See Fluid Cartridge Repair , page 35.
Fluid viscosity too low for proper seal with carbide seat	Install fluid cartridge 26B701 which includes a plastic seat and stainless steel ball (1500 psi rated models only).	
Fluid in air passages	Spray tip gasket leaking	Tighten retaining ring. See FIG. 8.
		Replace spray tip or spray tip gasket. See Spray Tip Gasket Replacement , page 39.
	Leaking around seat housing	Replace the seat gasket (carbide models only). See Fluid Cartridge Repair , page 35. The gasket must be replaced whenever the seat assembly is removed.
Slow fluid shut-off	Fluid buildup on fluid needle components	Replace the fluid cartridge. See Fluid Cartridge Replacement , page 34.
		Replace the fluid needle assembly. See Fluid Cartridge Repair , page 35.
		Clean the fluid cartridge. See Cleaning Procedure , page 22.
No fluid output when triggered	Spray tip is plugged	Clean spray tip. See Daily Gun Care , page 19.
	Fluid hose is plugged	Follow Pressure Relief Procedure , page 15. Very slowly loosen the hose end coupling to relieve pressure gradually. Loosen the nut or the coupling completely. Clear the obstruction in the hose. Then loosen completely to clear the obstruction.
	Fluid filter is plugged	Follow the Inline Fluid Filter Cleaning Procedure , page 21.

Repair

				
To avoid injury, follow Pressure Relief Procedure , page 15, before checking or repairing the gun.				

Check all possible remedies in the troubleshooting charts before disassembling the gun. See **Troubleshooting**, page 25.

Air Cartridge Replacement Procedure

Use an air cartridge replacement kit to replace the air cartridge assembly (21) and the u-cup (2). See **Fluid Cartridge Repair Kits**, page 58.

1. Follow the **Pressure Relief Procedure**, page 15.
2. Loosen the air cartridge assembly (21) from back of gun body with the gun tool (29).

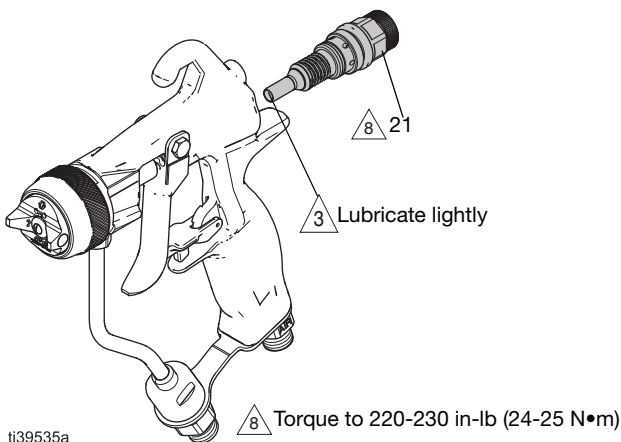

FIG. 43: Air cartridge installation

3. Slide assembly (21) out of the gun.
4. Follow the **U-Cup Replacement Procedure**, page 31 if needed.
5. Lubricate the air cartridge tip and thread the air cartridge assembly (21) into the back of the gun. Torque to Torque to 220 in-lb (24-25 N•m). See FIG. 43.

Trigger Procedure

Follow this procedure to remove and install the trigger assembly or to replace the trigger assembly with kit 26B721.

Remove the Trigger

1. Follow the **Pressure Relief Procedure**, page 15.
2. Use the nut driver (25) to loosen the trigger nut (11).
3. Remove the trigger pin (10) from the gun to release the trigger (9).

Install the Trigger

1. Position the trigger (9) between the washer and the housing.

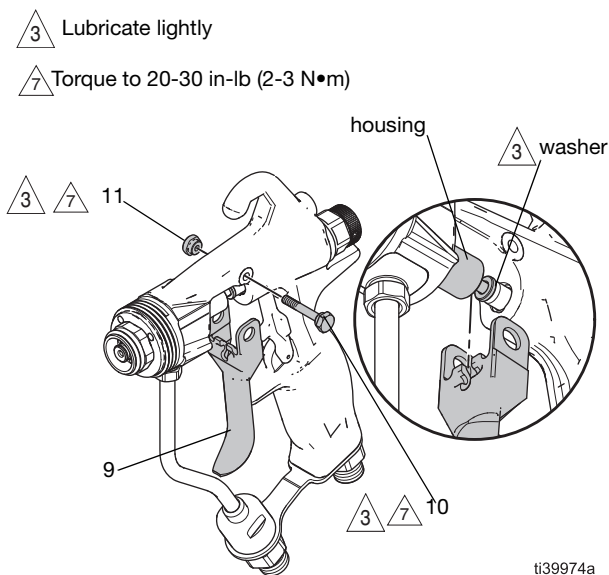

FIG. 44: Trigger placement

2. Insert the trigger pin (10).
3. Thread the trigger nut (11). Torque the trigger pin (10) and trigger nut (11) to 20-30 in-lb (2-3 N•m).

Air Cap Assembly Repair Procedure

Replace the air cap assembly (8) parts as needed. See **Air Cap Selection Guide**, page 56.

NOTE: RAC air cap assemblies cannot be repaired.

Disassemble the Air Cap

1. Follow the **Pressure Relief Procedure**, page 15.
2. Loosen the retaining ring (8b) by hand to remove the air cap assembly (8) from the gun.
3. Remove the spray tip (7) from the assembly.
4. Remove the o-ring (8d) with a pick to release the air cap (8a), and the washer (8f) from the assembly.

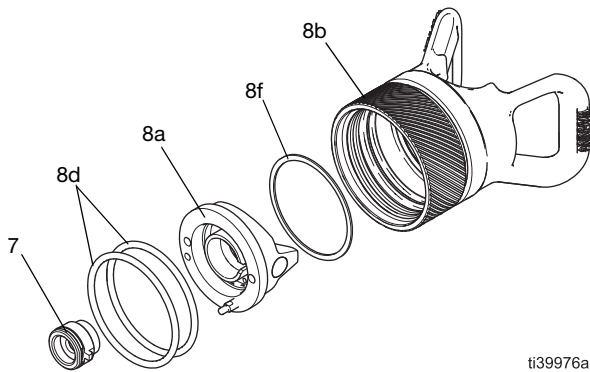

FIG. 45: PerformAA 50 air cap assembly parts and spray tip

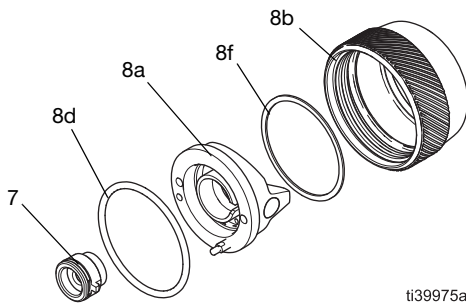

FIG. 46: PerformAA 15 air cap assembly parts and spray tip

Assemble the Air Cap

1. Place the washer (8f) onto the front of the air cap (8a).
2. Press the air cap (8a) and washer (8f) into the retaining ring (8b).

3. Install the o-ring (8d) into the retaining ring (8b) groove.

NOTE: Some models have two o-rings (8d). See FIG. 45.

4. Insert the spray tip (7) into the air cap (8a).
5. Install the air cap assembly (8) to the gun. See **Spray Tip and Air Cap Setup**, page 13.

U-Cup Replacement Procedure

1. Follow the **Pressure Relief Procedure**, page 15.
 2. Follow the **Remove Fluid Cartridge Procedure**, page 34.
 3. Remove the gun trigger (9) to access the u-cup (2) from the front of the gun. See **Remove the Trigger**, page 30.
 4. Use a thin metal pick or a flat head screwdriver to push the u-cup (2) from the front of the gun out the back of the gun.
- NOTE:** Removal damages the u-cup (2). It cannot be reused.
5. Place a new u-cup (2) on the seal installation tool (28), with the u-cup lips facing the tool. See FIG. 47.
 6. Firmly push the u-cup (2) into the back of the gun until the u-cup (2) snaps in place.
 7. Install the gun trigger (9). See **Install the Trigger**, page 30.

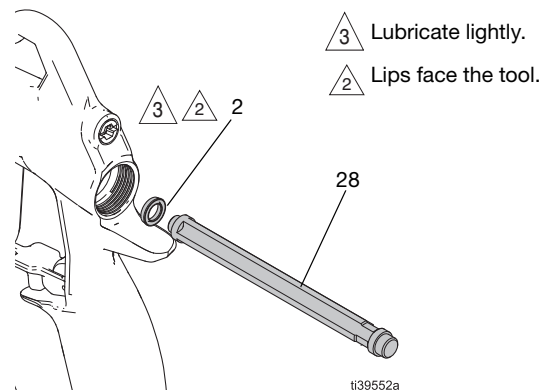

FIG. 47: U-cup installation

Air Cartridge Repair

1. Follow the **Pressure Relief Procedure**, page 15.
2. Loosen the air cartridge assembly (21) from back of the gun body with the gun tool (29).
3. Slide air cartridge assembly (21) out of the gun.
4. Disassemble the parts. See FIG. 48.
 - a. Pull the air valve assembly (21a) and spring (21b) from the cartridge enclosure (21d).
 - b. Remove the cartridge enclosure o-ring (21c).
 - c. Loosen setscrew (21h) and remove the fan adjustment knob (21g).
 - d. Remove the fan valve retaining ring (21j) with a pick.

NOTE: Use a hex wrench to press the fan valve assembly up to access the retaining ring (21j).

- e. Push the fan valve assembly (21e, 21f, 21k) out of the cartridge enclosure (21d).
- f. Loosen the fan adjustment nut (21e) to separate the fan valve stem (21f), and remove the fan valve seal (21k) with a pick.

5. Replace the air cartridge parts and rebuild.
 - a. Place the replacement fan valve o-ring (21k) onto the fan valve stem (21f). Thread the fan adjustment nut (21e) onto the stem (21f). Lubricate the o-ring (21k).
 - b. Push the assembled fan valve (21e and 21f) into the cartridge enclosure (21d).
 - c. Use a pick to press the retaining ring (21j) into place in the cartridge enclosure (21d) groove.
 - d. Place the fan adjustment knob (21g) onto the stem (21f) and tighten the set screw (21h) with a hex wrench.

NOTE: The setscrew is below flush when it is installed correctly into the stem (21f) detent.

- e. Install an o-ring (21c) onto the cartridge enclosure (21d). Lubricate the o-ring (21c).
 - f. Insert air valve (21a) into the spring (21b), and press the air valve (21a) into the cartridge enclosure (21d).
6. Follow the **U-Cup Replacement Procedure**, page 31.
 7. Lubricate the air valve tip (21a), and thread into the back of the gun. Torque to 220-230 in-lb (24-25 N•m). See FIG. 43.

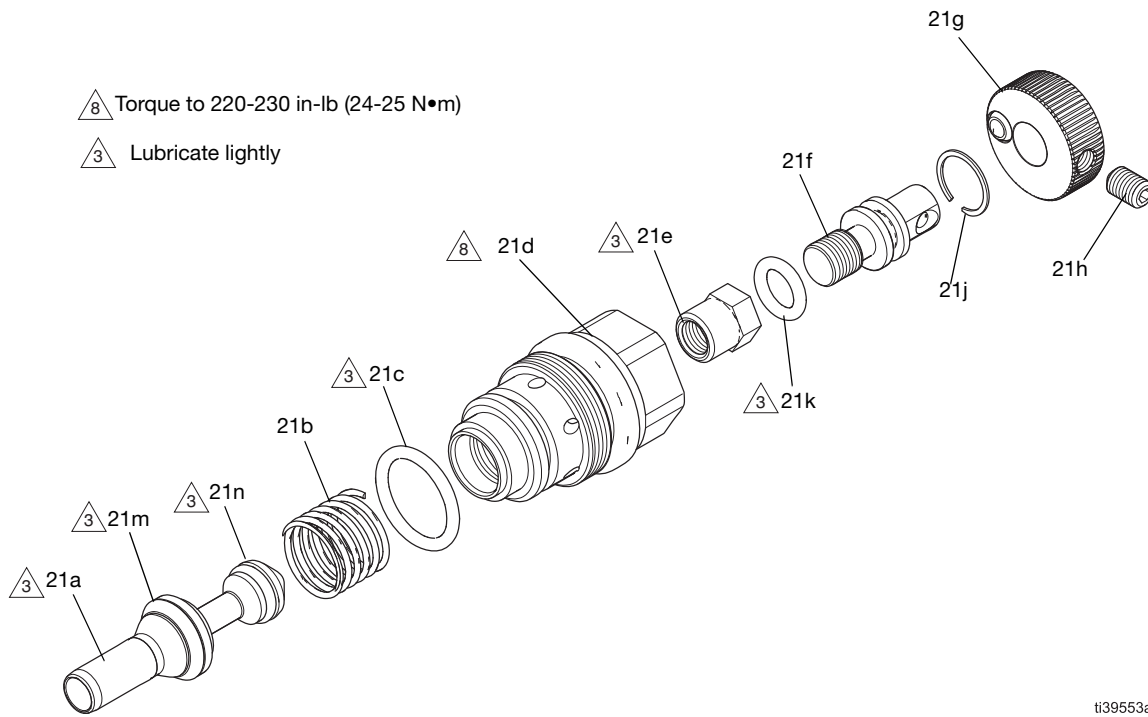

ti39553a

FIG. 48: Air cartridge assembly (for air assist models)

Air Valve Replacement

Replace the air valve (21a) with kit 26B713.

1. Follow the **Pressure Relief Procedure**, page 15.
2. Loosen the air cartridge assembly (21) from the back of the gun using the gun tool (29).
3. Pull the air cartridge assembly (21) out of the gun. See FIG. 43.
4. Follow the **U-Cup Replacement Procedure**, page 31.
5. Pull the air valve (21a) and spring (21b) from the cartridge enclosure (21d).
6. Insert a replacement air valve (21a) into the spring (21b), and press the spring (21b) into the cartridge enclosure (21d).
7. Lubricate the air valve (21a), and install the air cartridge assembly (21) into the back of the gun. Torque to 220-230 in-lb (24-25 N•m). See FIG. 43.

Fan Tube Replacement

Replace the fan tube with kit 26B715.

NOTE: RAC spray guns do not use a fan tube.

1. Follow the **Pressure Relief Procedure**, page 15.
2. Use a hex wrench to loosen the fan tube plug (18).
3. Pull the fan tube plug (18) out of the gun. Remove the fan tube (20) from the gun.
4. Insert a replacement fan tube (20) into the gun body.
5. Lubricate the o-ring (19) on the replacement fan tube plug (18).
6. Thread the fan tube plug (18) into the gun body. Tighten with a hex wrench.

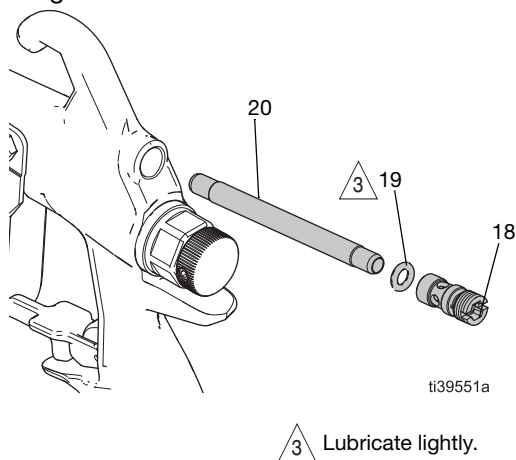

FIG. 49 Fan tube assembly

Fluid Cartridge Replacement

Replace the fluid cartridge (6) entirely with a compatible replacement kit. See **Fluid Cartridge Assembly**, page 49.

NOTE: Fluid cartridges vary by model. Some models have model identification markings. See **Fluid Cartridge Identification**, page 50.

Remove Fluid Cartridge Procedure

1. Follow the **Pressure Relief Procedure**, page 15.
2. Remove the fluid and air hoses from the gun.
3. Loosen the retaining ring (8b) by hand to remove the air cap assembly (8) and spray tip (7).

NOTE: Clean the air cap assembly (8) and spray tip (7) daily. See **Daily Gun Care**, page 19.

4. Trigger the gun while loosening the fluid cartridge (6) with the gun tool (29) until the cartridge spins freely.

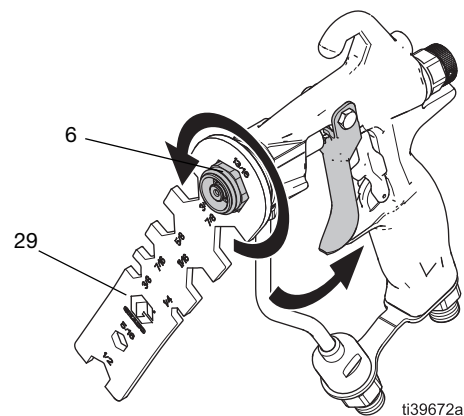
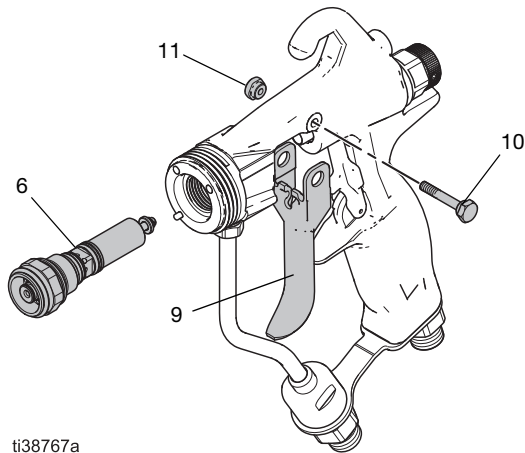

FIG. 50: Remove the fluid cartridge

NOTICE

Always trigger the gun to remove or tighten the fluid cartridge to prevent seat damage.

5. Follow the **Remove the Trigger**, page 30, instructions to release the fluid cartridge (6) from the gun.



ti38767a

FIG. 51: Remove the trigger to release the fluid cartridge

- Slide the fluid cartridge (6) out of the gun body.

Install Fluid Cartridge Procedure

- Lightly lubricate the cartridge o-rings (6e and 6c).
- Thread the cartridge 1-2 turns into the gun body until the trigger assembly (9) can fit between the needle washer and housing. See FIG. 44: Trigger placement, page 30.
- Install the trigger (9), trigger pin (11) and trigger nut (10) in front of the washer. See **Install the Trigger**, page 30.

 Torque to 175-185 in-lb (20-21 N•m)

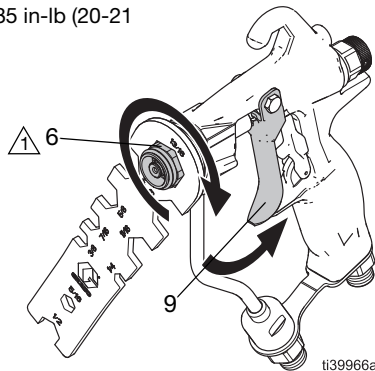

ti39966a

FIG. 52: Depress the trigger while threading the cartridge

- Depress the trigger (9) and thread the fluid cartridge (6) into the gun. Torque to 175-185 in-lb (20-21 N•m).

NOTE: Depress the trigger while torquing the cartridge.

- Install air cap assembly (8). See **Spray Tip and Air Cap Setup**, page 13.

Fluid Cartridge Repair

Rebuild the fluid cartridge or replace fluid cartridge parts with a compatible repair kit. See **Fluid Cartridge Repair Kits**, page 58.

- Follow the **Pressure Relief Procedure**, page 15.
- Remove Fluid Cartridge Procedure**, page 34, to remove the fluid cartridge assembly (6) from the gun.
- Separate needle assembly (6b) and diffuser assembly (6a) with the gun tool (29) and a vise tool.
- Remove the needle assembly (6b) outer o-rings (6c) and the inner o-ring (6c).

NOTE: Push the back of the needle forward to access inner o-ring.

- Remove worn thread tape from the needle assembly (6b)
- Remove outer diffuser o-rings (6d and 6e).
- Replace the diffuser (6a) parts.
 - Hold the diffuser housing (6m) with a wrench and loosen the seat nut (6f) with a hex wrench.
 - Remove the seat (6g), gasket (6h), and seat nut (6f) from the diffuser housing (6m).

NOTE: The gasket (6h) may get stuck. Use a pick to remove.

- Rebuild the diffuser (6a).
 - Use a pick to press the seat gasket (6h) into the diffuser housing (6m).
 - Place the seat (6g) into the diffuser housing (6m).

Fluid Tube Assembly Replacement

Replace the fluid tube assembly (13). See **Fluid Tube Repair Kits**, page 58.

1. Follow the **Pressure Relief Procedure**, page 15.
2. Follow the **Remove Fluid Cartridge Procedure**, page 34.
3. Remove the air inlet fitting (16) with the gun tool (29).
4. Remove the screw (17) using a 3/16 in hex wrench.
5. Slide the fluid tube assembly (13) out of the gun body.
6. Install a new fluid tube assembly (13) into the gun.
7. Install the fluid tube screw (17) with a 3/16 in. hex wrench. Torque to 50-60 in-lb (6-7 N•m).
8. Install the air inlet (16). Torque 175-185 in-lb (20-21N•m).
9. Install a fluid swivel (22) (if using) onto the fluid inlet fitting (15) with the gun tool (29).
10. Follow the **Install Fluid Cartridge Procedure**, page 35, to replace the trigger (9) and the fluid cartridge assembly (6).

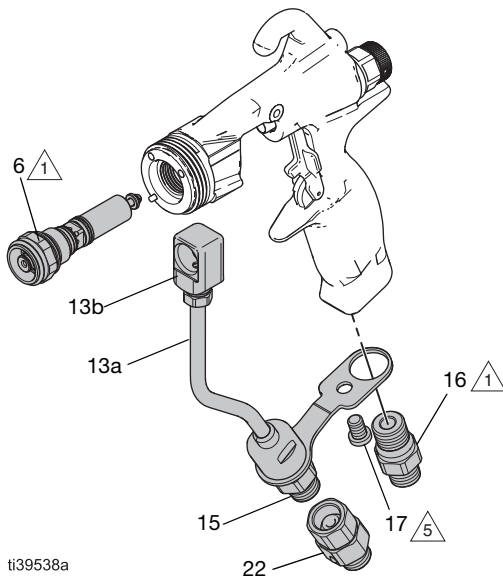

 Torque to 175-185 in-lb (20-21 N•m)

 Torque to 50-60 in-lb (6-7 N•m)

FIG. 54: Fluid tube replacement

Fluid Tube Gasket Replacement

1. Follow the **Pressure Relief Procedure**, page 15.
2. Remove the fluid tube assembly (13).
 - a. Remove the air inlet fitting (16) with the gun tool (29).
 - b. Remove the screw (17) with a 3/16 in. hex wrench.
 - c. Loosen the top of the fluid tube nut (13d) from the fluid tube enclosure (13b) with the gun tool (29) or a wrench.
 - d. Separate the fluid tube from the gun.
3. Use a pick to remove the fluid tube gasket (13c) from the cartridge insert (13b).
4. Place a new gasket (13c) into the cartridge insert (13b).
5. Assemble the spray gun.
 - a. Thread the fluid tube nut (13d) into the cartridge insert (13b). Do not tighten.
 - b. Install the fluid tube screw (17) with a 3/16 in. hex wrench. Torque to 50-60 in-lb (6-7 N•m).
 - c. Tighten the fluid tube nut (13d) into the cartridge insert (13b). Torque to 150-160 in-lb (17-18 N•m).
 - d. Thread the air inlet fitting (16). Torque to 175-185 in-lb (20-21 N•m).



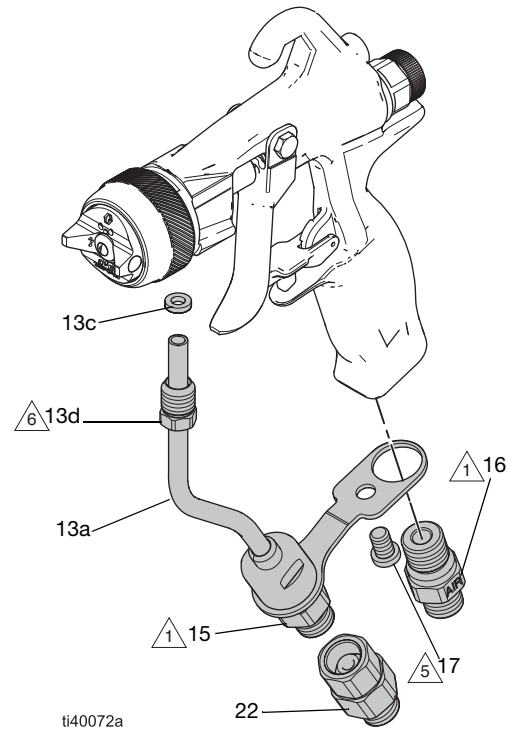

-  Torque to 175-185 in-lb (20-21 N•m)
-  Torque to 50-60 in-lb (6-7 N•m)
-  Torque to 150-160 in-lb (17-18 N•m)

FIG. 55: Fluid tube gasket replacement

Spray Tip Gasket Replacement

Replace the spray tip gasket (7a) with a compatible replacement part. See **Spray Tip Kits**, page 58.

Follow the **Reverse-A-Clean® (RAC) Setup**, page 14 to replace RAC spray tip parts.

NOTE: Some AXM spray tip gaskets include a filter. See **AXM Spray Tip Chart**, page 53.

1. Follow the **Pressure Relief Procedure**, page 15.
2. Separate the spray tip (7) from the gun. See **Disassemble the Air Cap**, page 31.
3. Use a pick to remove the gasket (7a) from the spray tip (7).
4. Press the replacement gasket (7a) into the spray tip (7).

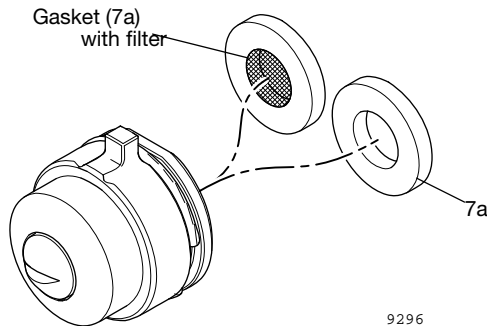

FIG. 56: Spray tip gasket options

5. Install the spray tip and the air cap. See **Assemble the Air Cap**, page 31

RAC Conversion Instructions

Convert air assist gun model to or from a RAC gun model with a conversion kit. See **Reverse-a-Clean Kits**, page 59.

1. Follow the **Pressure Relief Procedure**, page 15.
2. Remove the air cap assembly (8). See **Disassemble the Air Cap**, page 31.
3. Remove the fluid cartridge (6). Follow the **Remove Fluid Cartridge Procedure**, page 34.

NOTE: Replace the u-cup (2) if needed. See **U-Cup Replacement Procedure**, page 31.

4. Remove and replace the air cartridge. Follow the **Air Cartridge Replacement Procedure**, page 30.
5. Install a replacement Fluid Cartridge (6). Follow the **Install Fluid Cartridge Procedure**, page 35.
6. Setup the replacement air cap assembly (8).
 - **Reverse-A-Clean® (RAC) Setup**, page 14.
 - **Spray Tip and Air Cap Setup**, page 13.
7. Replace fan tube parts. See **Fan Tube Replacement**, page 34 for reference.

NOTE: RAC spray guns do not use a fan tube.

- a. Remove the fan tube plug (18).
- b. **Air assist to RAC air assist kits:** Remove the fan tube (20).

RAC Air Assist to air assist kits: Install a fan tube (20).

- c. Install fan tube plug (18).

Parts

PerformAA 15 Air Assist Gun Models

Models 26B500, 26B501, 26B502, 26B503, 26B504, and 26B505.

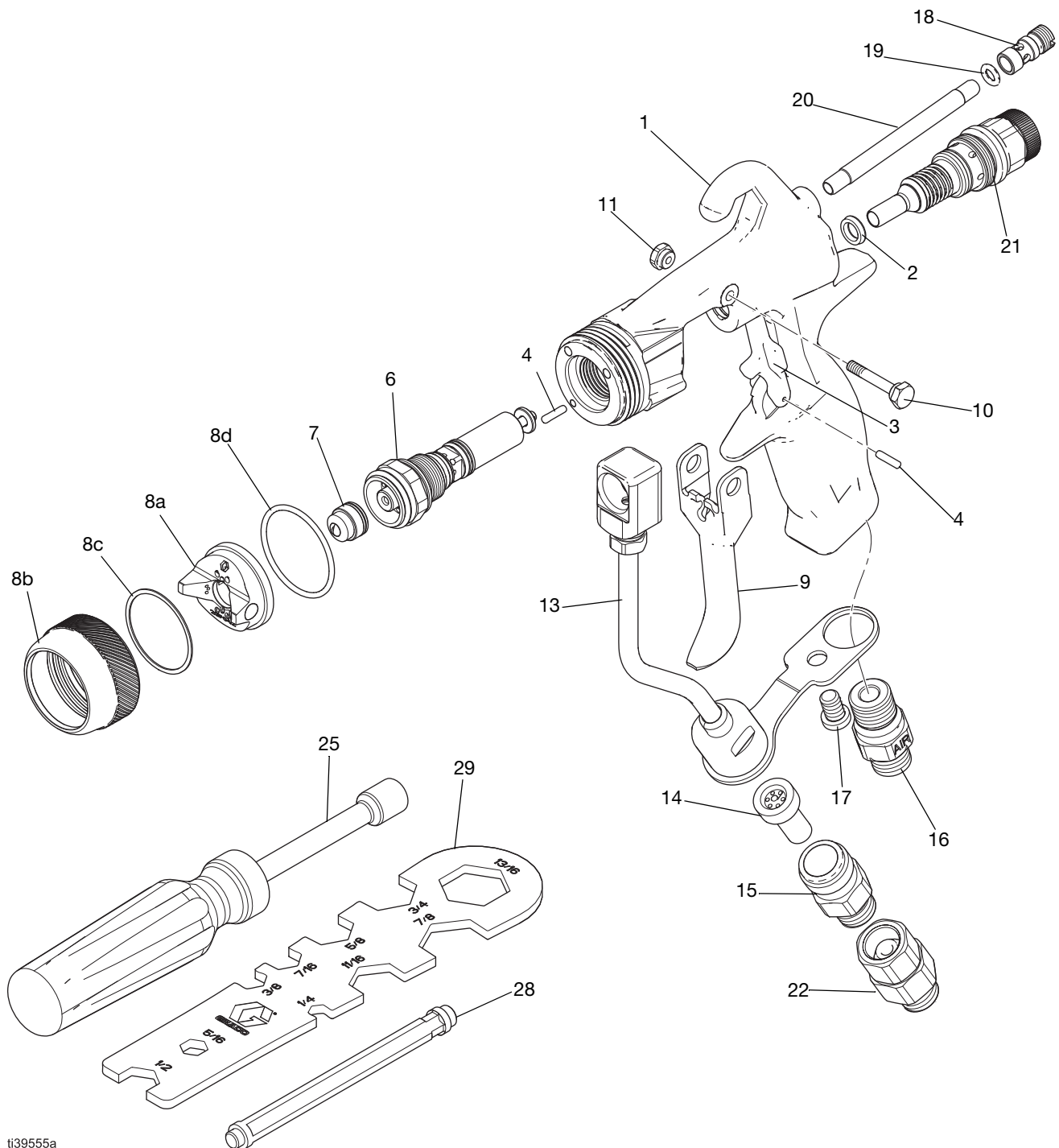

ti39555a

PerformAA 15 Air Assist Gun Models

Models 26B500, 26B501, 26B502, 26B503, 26B504, and 26B505

Ref. No.	Part No.	Description	Qty.
1	--	BODY, gun	1
2	188493	PACKING, U-CUP, gun	1
3	249423	STOP, TRIGGER (includes item 4)	1
4	115132	PIN, DOWEL	2
6†	26B700	CARTRIDGE, FLUID (Models 26B500 and 26B501)	1
	26B701	CARTRIDGE, FLUID, 1500, SST Plastic (Model 26B504)	1
	26B702	CARTRIDGE, FLUID, WL, LV (Models 26B502, and 26B503, 26B505)	1
7	--	SPRAY TIP, Customer's Choice of AXM or AXF, See Spray Tip Charts , page 52	1
8	--	AIR CAP, ASSY.; includes 8a, 8b, 8c, and 8d; see Air Cap Selection Guide , page 56	1
8a	2GF042	AIR CAP, general finishing (Models 26B500, 26B501, and 26B504)	1
	2WL042	AIR CAP, wood lacquer (Models 26B502 and 26B503)	1
	2LV042	AIR CAP, low viscosity (Model 26B505)	1
8b	26B800	RING, RETAINING (includes 8c and 8d)	1
8c	15G320	WASHER, PTFE	1
8d	109213	PACKING, O-ring, PTFE	1
9	26B721	TRIGGER, GUN (includes 10 and 11)	1

10	15F739	PIN, PIVOT	1
11	15F740	PIN, PIVOT, NUT	1
13	26B711	KIT, FLUID TUBE, filter (includes 14, 15, and 17), See Fluid Tube Assembly Parts , page 51.	1
14	205264	FILTER, TIP	1
15	24D437	FITTING, HOSE, filter	1
16	26B867	FITTING, AIR	1
17	119996	SCREW, CAP, SCKT, LH, 1/4-20X3/8	1
18	--	PLUG, FAN AIR (purchase kit 26B715: includes 18, 19, and 20)	1
19	112319	PACKING, O-RING	1
20	--	TUBE, FAN AIR (purchase kit 26B715: includes 18, 19, and 20)	1
21	26B713	CARTRIDGE, AIR VALVE (includes item 2 and 28) See Air Cartridge Assembly , page 48	1
22	189018	SWIVEL (Models 26B501, 26B503, 26B505)	1
25	117642	TOOL, NUT DRIVER, 5/16"	1
26▲	222385	LABEL, SAFETY, WARNING, MED. ALERT, not shown	1
27▲	172479	TAG, INSTRUCTION, not shown	1
28	192282	TOOL, INSTALLATION, SEAL	1
29	15F446	TOOL, GUN	1

† See **Fluid Cartridge Assembly**, page 49.

▲ Replacement safety labels, tags, and cards are available at no cost.

PerformAA 50 Air Assist Gun Models

Models 26B509, 26B510, 26B511, 26B512, 26B513, 26B514, 26B515, and 26B516

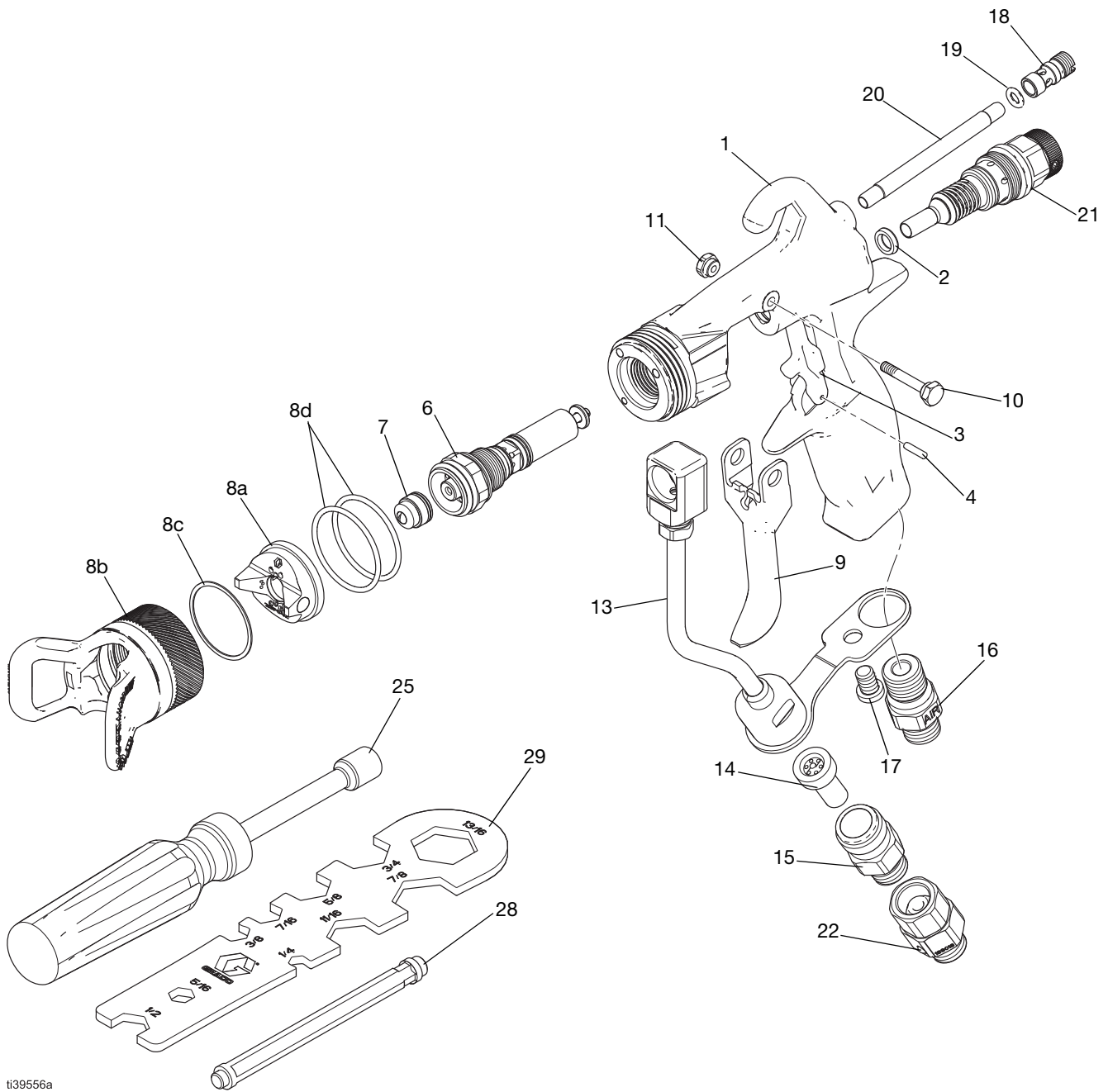

ti39556a

PerformAA 50 Air Assist Gun Models

Models 26B509, 26B510, 26B511, 26B512, 26B513, 26B514, 26B515, and 26B516

Ref. No.	Part No.	Description	Qty.
1	—	BODY, gun	1
2	188493	PACKING, U-CUP, GUN	1
3	249423	STOP, TRIGGER (kit includes item 4)	1
4	115132	PIN, DOWEL	1
6	26B700	CARTRIDGE, FLUID, see Fluid Cartridge Assembly , page 49	1
7	—	SPRAY TIP, Customer's Choice of AXM or AXF, see Spray Tip Charts , page 52	1
8		AIR CAP, ASSY.; includes 8a, 8b, 8c, and 8d; see Air Cap Selection Guide , page 56.	1
8a	2GF042	AIR CAP, general finishing (26B510, 26B511, 26B509)	1
	2WL042	AIR CAP, wood lacquer (26B512)	1
	2HV042	AIR CAP, high viscosity (26B513)	1
	2WB042	AIR CAP, waterborne (26B514)	1
	2QD042	AIR CAP, quick drying (26B515)	1
	2LV042	AIR CAP, low viscosity (26B516)	1
8b	26B801	RETAINING RING (kit includes 8c and 8d)	1
8c	15G320	WASHER, PTFE	1
8d	109213	PACKING, O-ring, PTFE	2
9	26B721	TRIGGER, GUN (kit includes 10 and 11)	1
10	15F739	PIN, PIVOT	1
11	15F740	PIN, PIVOT, NUT	1

13	26B711	KIT, FLUID TUBE, filter, all models except 26B509, (kit includes 14, 15, and 17) See Fluid Tube Assembly Parts , page 51.	1
13	26B712	KIT, FLUID TUBE, high flow model 26B509 (kit includes 17), see Fluid Tube Assembly Parts , page 51.	1
14	205264	FILTER, TIP (not included in 26B509), see Inline Fluid Filter Kits , page 58	1
15	24D437	FITTING, HOSE, FILTER (not included in 26B509)	1
16	26B867	FITTING, AIR	1
17	119996	SCREW, CAP, SCKT, LH, 1/4-20X3/8	1
18	—	PLUG, FAN AIR, (purchase kit 26B715: includes 18, 19, and 20)	1
19	112319	PACKING, O-RING	1
20	—	TUBE, FAN AIR (purchase kit 26B715: includes 18, 19,20)	1
21	26B713	CARTRIDGE, AIR VALVE (kit includes item 2 and 28), see Air Cartridge Assembly , page 48	1
22	189018	SWIVEL (Models 26B511, 26B512, 26B513, 26B514, 26B515, and 26B516)	1
25	117642	TOOL, NUT DRIVER, 5/16"	1
26▲	222385	LABEL, SAFETY, WARNING, MED. ALERT, not shown	1
27▲	172479	TAG, INSTRUCTION, not shown	1
28	192282	TOOL, INSTALLATION, SEAL	1
29	15F446	TOOL, GUN	1

▲Replacement safety labels, tags, and cards are available at no cost.

PerformAA RAC Air Assist Gun Models

Models 26B517 and 26B518

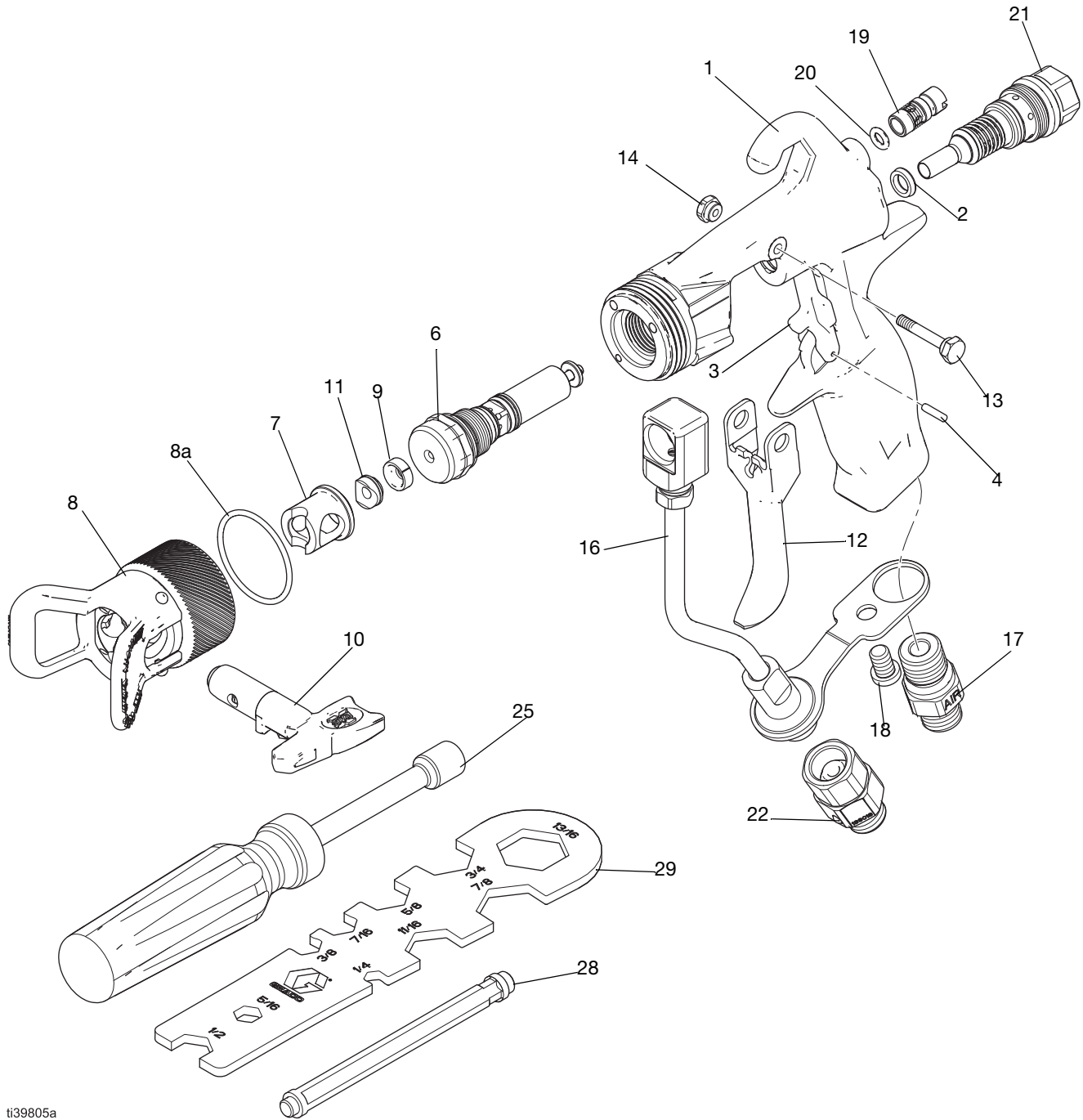

ti39805a

PerformAA RAC Air Assist Gun Models

Models 26B517 and 26B518

Ref No.	Part No.	Description	Qty.
1	--	BODY, gun	1
2	188493	PACKING, U-CUP, GUN	1
3	249423	STOP, TRIGGER (kit includes item 4)	1
4	115132	PIN, DOWEL	1
6	26B703	CARTRIDGE, FLUID, see Fluid Cartridge Repair Kits , page 58	1
7	15F442	HOUSING, RAC	1
8	26B869	AIR CAP, RAC, PERFORMAA (kit includes 7)	1
8a	109213	PACKING, O-ring, PTFE	1
9	15E557	GASKET, TIP	1
10	--	SPRAY TIP, Customer's Choice of LTX or FFLP, see PerformAA RAC SwitchTips , page 55.	1
11	15A981	SEAT, CYLINDER	1
12	26B721	TRIGGER, GUN (kit includes 13 and 14)	1
13	15F739	PIN, PIVOT	1
14	15F740	PIN, PIVOT, NUT	1
16	26B712	KIT, FLUID TUBE, high flow (includes 18). See Fluid Tube Assembly Parts , page 51.	1

17	26B867	FITTING, AIR	1
18	119996	SCREW, CAP, SCKT, LH, 1/4-20X3/8	1
19	26B915	PLUG, FAN AIR; includes 19 and 20	1
20	112319	PACKING, O-RING	1
21	26B717	CARTRIDGE, AIR VALVE, FIXED (kit includes item 2 and 28), Air Cartridge Assembly , page 48	1
22	189018	SWIVEL (Model 26B518)	1
25	117642	TOOL, NUT DRIVER, 5/16"	1
26▲	222385	LABEL, SAFETY, WARNING, MED. ALERT, not shown	1
27▲	172479	TAG, INSTRUCTION, not shown	1
28	192282	TOOL, INSTALLATION, SEAL	1
29	15F446	TOOL, GUN	1

▲Replacement safety labels, tags, and cards are available at no cost.

PerformAA Airless Gun Models

Models 26B519 and 26B520

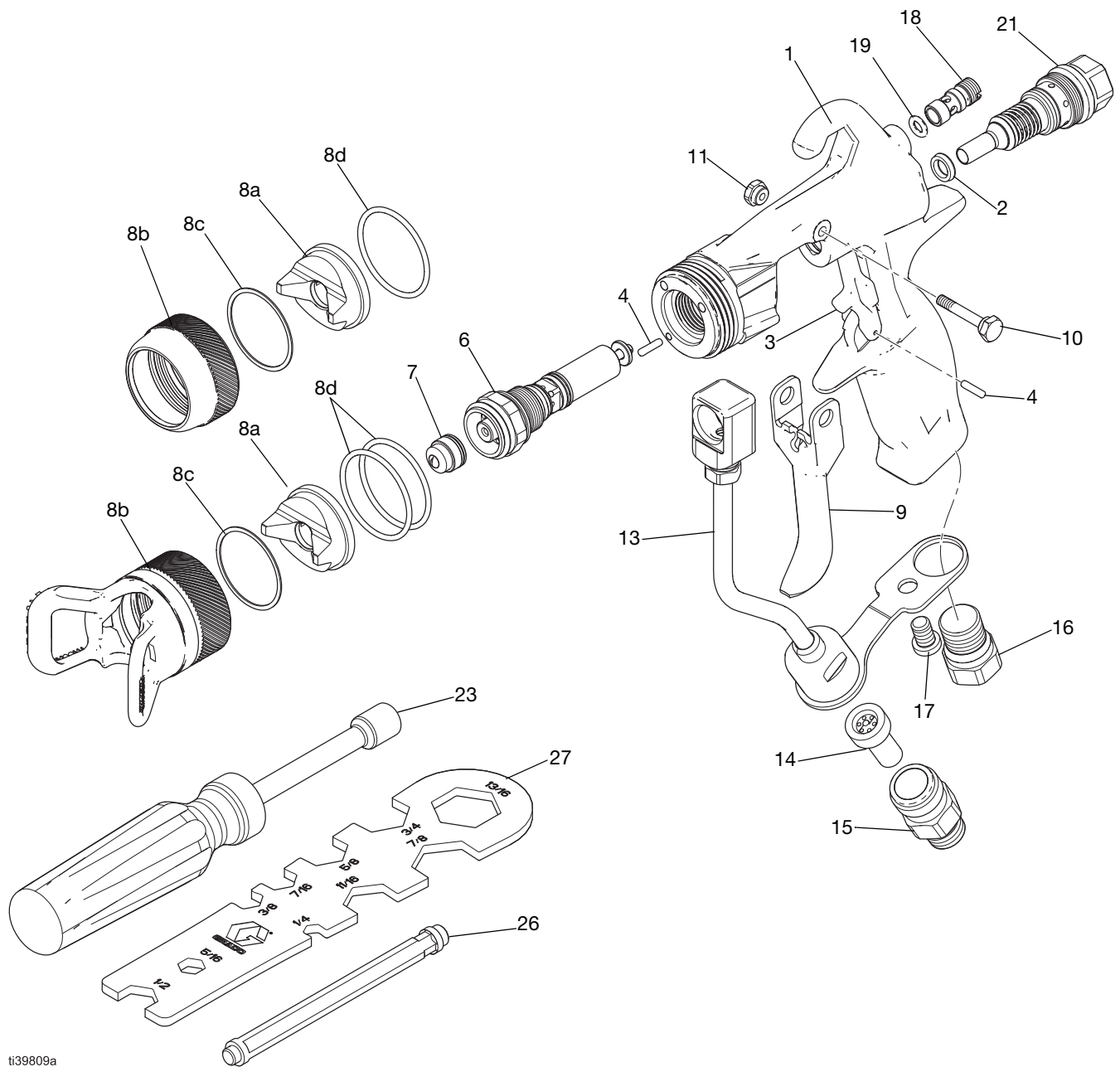

ti39809a

PerformAA Airless Gun Models

Models 26B519 and 26B520

Ref. No.	Part No.	Description	Qty.
1	--	BODY, gun	1
2	188493	PACKING, U-CUP, gun	1
3	249423	STOP, TRIGGER (kit includes item 4)	1
4	115132	PIN, DOWEL, model 26B519	2
		PIN, DOWEL, model 26B520	1
6	26B700	CARTRIDGE, FLUID, see Fluid Cartridge Assembly , page 49	1
7	--	Spray Tip, Customer's Choice of AXM or AXF, see Spray Tip Charts , page 52	1
8	--	AIR CAP, ASSY., airless; includes 8a, 8b, 8c, and 8d; see Air Cap Selection Guide , page 56	1
8a	2AL042	AIR CAP, airless	1
8b	26B800	RETAINING RING, model 26B519 (kit includes 8c and 8d)	1
	26B801	RETAINING RING, model 26B520 (kit includes 8c and 8d)	1
8c	15G320	WASHER, PTFE	1
8d	109213	PACKING, O-RING, PTFE (model 26B519)	1
		PACKING, O-RING, PTFE (model 26B520)	2
9	26B721	TRIGGER, GUN, (kit includes items 10 and 11)	1

10	15F739	PIN, PIVOT	1
11	15F740	PIN, PIVOT, NUT	1
13	26B711	KIT, FLUID TUBE, filter (kit includes 14, 15, and 17) See Fluid Tube Assembly Parts , page 51.	1
14	205264	FILTER, TIP, see Inline Fluid Filter Kits , page 58 for options	1
15	24D437	FITTING, HOSE, filter	1
16	26B868	PLUG, AIR, AIRLESS	1
17	119996	SCREW, CAP, SCKT, LH, 1/4-20X3/8	1
18	--	PLUG, FAN AIR (Purchase kit 26B915: includes 18 and 19)	1
19	112319	PACKING, O-RING	1
21	26B717	CARTRIDGE, AIR VALVE, FIXED (kit includes item 2 and 28) See Air Cartridge Assembly , page 48	1
23	117642	TOOL, NUT DRIVER, 5/16"	1
24▲	222385	LABEL, SAFETY, WARNING, MED. ALERT, not shown	1
25▲	172479	TAG, INSTRUCTION	1
26	192282	TOOL, INSTALLATION, SEAL	1
27	15F446	TOOL, GUN	1

▲Replacement safety labels, tags, and cards are available at no cost.

Air Cartridge Assembly

26B713: Air Cartridge Assembly Kit with a fan adjustment knob for air assist models

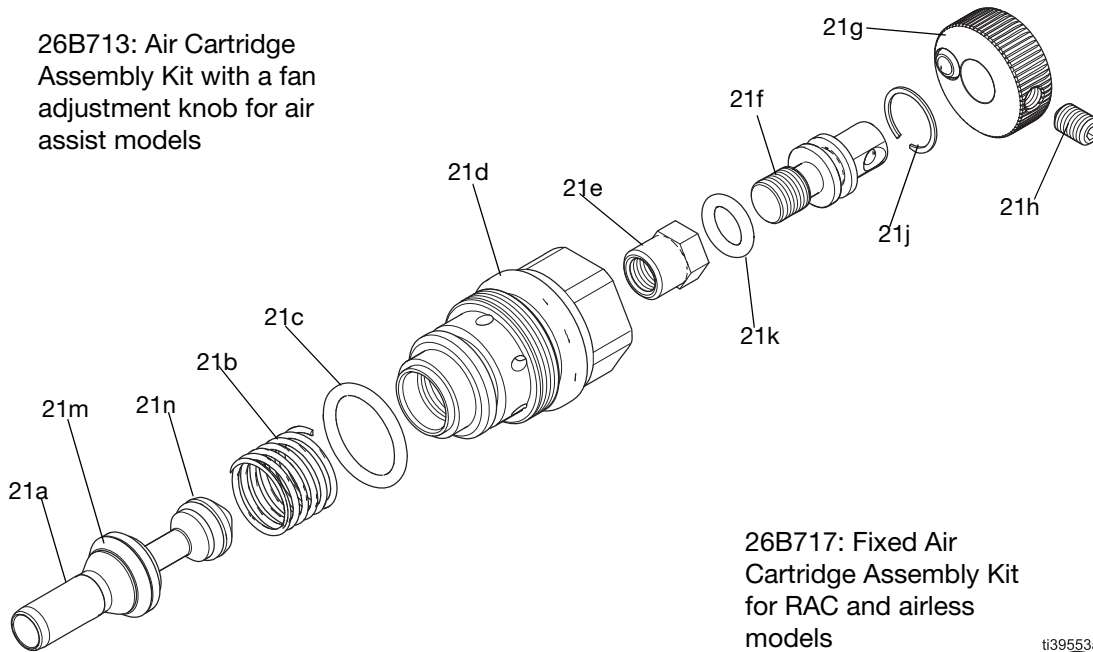

26B717: Fixed Air Cartridge Assembly Kit for RAC and airless models

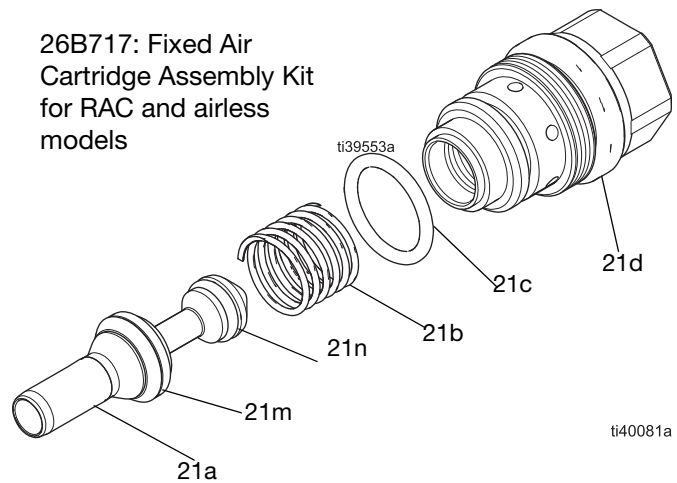

ti40081a

Ref. No.	Part Number	Description	Qty
2	188493	PACKING, u-cup, gun (not shown)	1
21a	26B716	VALVE, ASSY., AIR (includes 21m, 21n, 2, and 26)	1
21b	114069	SPRING, COMPRESSION	1
21c	113746	PACKING, O-RING	1
21d	—	HOUSING, CARTRIDGE	1
21e*	—	NUT, FAN ADJUSTMENT	1
21*	—	STEM, FAN VALVE	1

21g*	26B914	KNOB, FAN ADJUSTMENT (kit includes 21h)	1
21h*	GC2082	SCREW, set	1
21j*	19B708	RING, RETAINING, INTERNAL	1
21k*	111450	PACKING, O-RING, fan valve	1
21m	15F488	PACKING, U-CUP, air valve	1
21n	111508	PACKING, O-RING	1
26	192282	TOOL, INSTALLATION, seal (not shown)	1

*Not included in 26B717

Fluid Cartridge Assembly

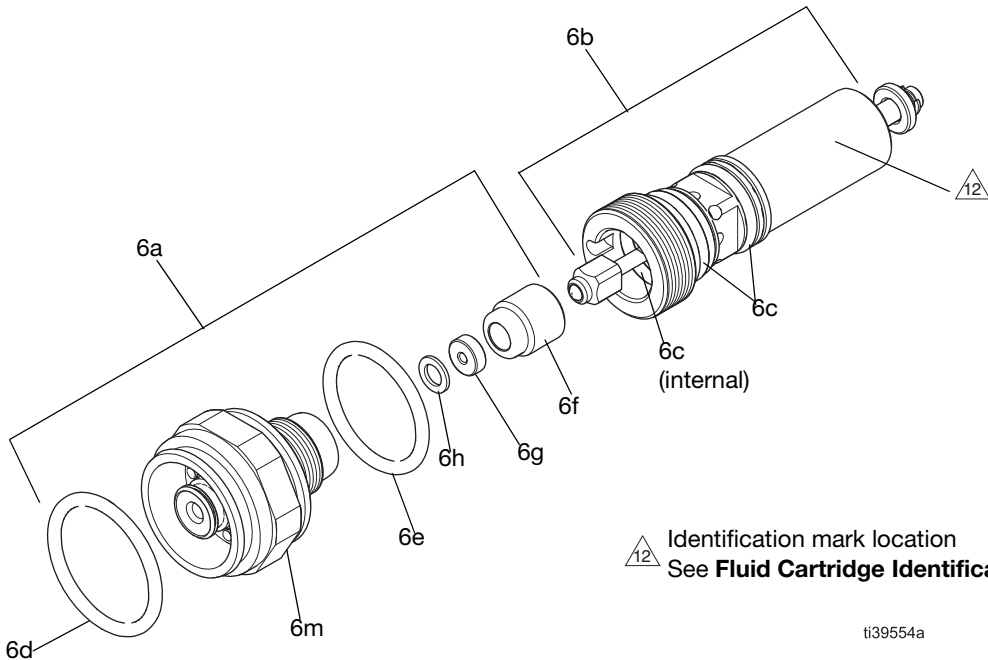

△ Identification mark location
See **Fluid Cartridge Identification**, page 50

t139554a

26B700 Fluid Cartridge Kit PerformAA with carbide ball and seat

Used in models 26B500, 26B501, 26B509, 26B510, 26B511, 26B512, 26B513, 26B514, 26B515, 26B516, 26B519, 26B520. Identified with no markings on 6b. Not Compatible with RAC models.

Ref. No.	Part No.	Description	Qty.
6a	26B707	KIT DIFFUSER carbide seat; kit includes 1 o-ring (6c)	1
6b	26B704	KIT, NEEDLE ASSEMBLY	1
6c+	111316	PACKING, O-RING	3
6d+	111116	PACKING, O-RING	1
6e+	116768	PACKING, O-RING	1
6f	—	NUT SEAT, purchase kit 26B710	1
6g	—	SEAT, CARBIDE, purchase kit 26B710	1
6h+	—	GASKET, SEAT, purchase kit 26B710	1

⊕ Included in Fluid Cartridge Seal Kit (26B706). See **Fluid Cartridge Repair Kits**, page 58.

26B701 Fluid Cartridge Kit with stainless steel ball, plastic seat, and low viscosity spring.

Use in model 26B504. Identified with two markings on 6b. Not compatible with PerformAA 50 or RAC models.

Ref. No.	Part No.	Description	Qty.
6a	26B708	KIT DIFFUSER, plastic seat; kit includes 1 o-ring (6c)	1
6b	26B705	KIT, NEEDLE ASSEMBLY, stainless steel	1
6c+	111316	PACKING, O-RING	3
6d+	111116	PACKING, O-RING	1
6e+	116768	PACKING, O-RING	1
6f†	—	NUT, SEAT, purchase kit 249424	1
6g†	—	SEAT, PLASTIC, purchase kit 249424	1

⊕ Included in Fluid Cartridge Seal Kit (26B706). See **Fluid Cartridge Repair Kits**, page 58.

† Included in Plastic Seat Repair Kit (249424). See **Plastic Seat Repair Kits**, page 58.

26B702 Fluid Cartridge Kit: Wood Lacquer and Low Viscosity with carbide ball and seat and low viscosity spring.

Used in models 26B502, 26B503, and 26B505. Not compatible with PerformAA 50 or RAC models.

Ref. No.	Part No.	Description	Qty.
6a	26B707	KIT DIFFUSER, carbide seat, kit includes 1 o-ring (6c)	1
6b	26B880	KIT, NEEDLE ASSEMBLY, wood Lacquer, low viscosity	1
6c+	111316	PACKING, O-RING	3
6d+	111116	PACKING, O-RING	1
6e+	116768	PACKING, O-RING	1
6f	—	NUT, SEAT purchase kit 26B710	1
6g	—	SEAT CARBIDE purchase kit 26B710	1
6h+	—	GASKET, SEAT, purchase kit 26B710	1

+ Included in Fluid Cartridge Seal Kit (26B706). See **Carbide Seat Repair Kits**, page 58

26B703 RAC Fluid Cartridge Kit with carbide ball and seat.

Used in models 26B517 and 26B518. Not compatible with other models.

Ref. No.	Part No.	Description	Qty.
6a	26B709	KIT DIFFUSER, RAC, kit includes 1 o-ring (6c)	1
6b	26B704	KIT, NEEDLE, ASSEMBLY	1
6c+	111316	PACKING, O-RING	3
6e+	116768	PACKING, O-RING	1
6f	—	NUT, SEAT, purchase kit 26B710	1
6g	—	SEAT, CARBIDE, purchase kit 26B710	1
6h+	—	GASKET, SEAT, purchase kit 26B710	1

+ Included in Fluid Cartridge Seal Kit (26B706). See **Carbide Seat Repair Kits**, page 58

Fluid Cartridge Identification

Model 26B700

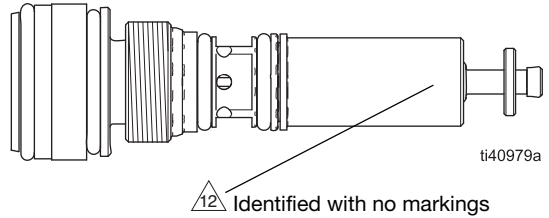

Model 26B701

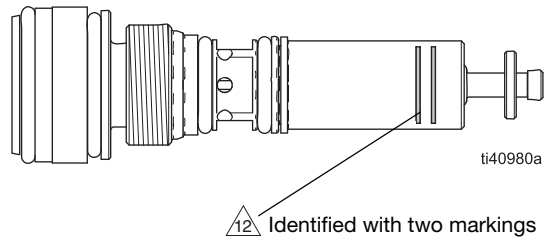

Model 26B702

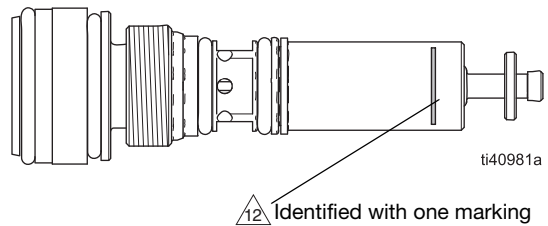

Fluid Tube Assembly Parts

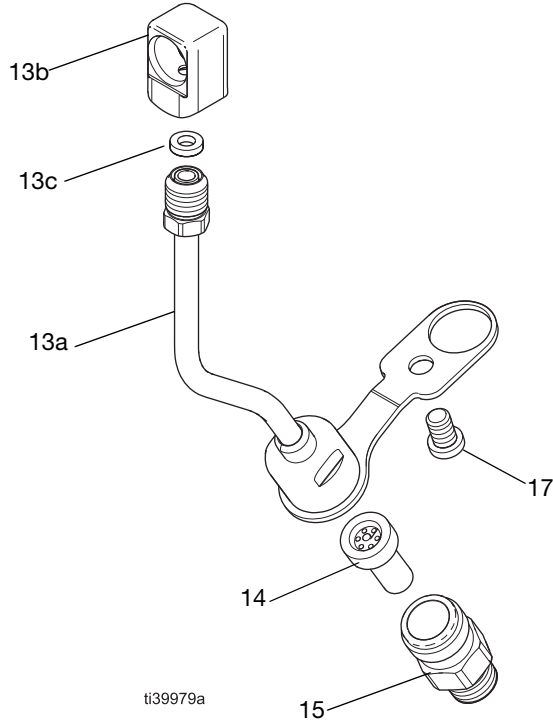

FIG. 57: Fluid tube assembly: model 26B711

26B711 Fluid Tube Kit with filter.

Used in all gun models except 26B509, 26B517, and 26B518.

Ref. No.	Part No.	Description	Qty.
13a	24D436	FLUID TUBE, includes 13c	1
13b	—	INSERT, CARTRIDGE, fluid tube	1
13c	115133	GASKET, fluid tube	1
14	205264	FILTER, TIP, See Inline Fluid Filter Kits , page 58	1
15	24D437	FITTING, HOSE, FILTER	1
17	119996	SCREW, CAP, SCKT, LH, 1/4-20X3/8	1

26B712 High Flow Fluid Tube Kit

Use in high flow gun models 26B509, 26B517, and 26B518.

Ref. No.	Part No.	Description	Qty.
13a	249317	FLUID TUBE	1
13b	—	INSERT, CARTRIDGE, fluid tube	1
13c	115133	GASKET, fluid tube	1
17	119996	SCREW, CAP, SCKT, LH, 1/4-20X3/8	1

Spray Tip Charts

PerformAA 15, PerformAA 50, and PerformAA Airless Spray Tips



To reduce the risk of injury, including skin injection:

- Follow the **Pressure Relief Procedure**, page 15, before removing or installing a spray tip or an air cap.
- Do not use spray tips in the gray shaded area of the Spray Tip Selection Chart with PerformAA 15 guns.
- Never exceed the maximum working fluid pressure for your gun model.

The spray tips in the gray shaded area can only be used with 5000 psi (34.5 MPa, 345 bar) rated spray guns.

PerformAA models are compatible with the following spray tips:

AXM Fine Finish Spray Tips (AXMxxx):

Recommended for high finish quality applications. Use the **AXM Spray Tip Chart**, page 53.

AXF Fine Finish Pre-Orifice Spray Tips (AXFxxx):

AXF tips have a pre-orifice that assists in atomizing sheer thinning materials, including lacquers. Use the **AXF Fine Finish Pre-Orifice Spray Tip Chart**, page 54.

Order desired tip, where xxx = 3-digit number from matrix 1 or 2. Example: AXM611 is the AXM Fine Finish Spray Tip with a 0.011 in. (0.279 mm) orifice and a maximum spray pattern of 12 to 14 inches (350 mm).

Table 1: AXM Spray Tip Chart

Orifice Size in. (mm)	* Fluid Output 2000 psi (14.0 MPa, 140 bar) fl oz/min (lpm)		❖ Maximum Pattern Width at 12 in. (305 mm) in. (mm)								
	at 600 psi (4.1 MPa, 41 bar)	at 1000 psi (7.0 MPa, 70 bar)	2 to 4 (75)	4 to 6 (150)	6 to 8 (200)	8 to 10 (250)	10 to 12 (300)	12 to 14 (350)	14 to 16 (400)	16 to 18 (450)	18 to 20 (500)
†0.007 (0.178)	4.0 (0.1)	5.2 (0.15)	107	207	307	—	—	—	—	—	—
†0.009 (0.229)	7.0 (0.2)	9.1 (0.27)	109	209	309	409	509	609	—	—	—
†0.011 (0.279)	9.5 (0.28)	12.5 (0.37)	111	211	311	411	511	611	711	—	—
0.013 (0.330)	12.0 (0.35)	16.0 (0.47)	113	213	313	413	513	613	713	—	—
0.015 (0.381)	16.0 (0.47)	21.0 (0.62)	—	215	315	415	515	615	715	815	—
0.017 (0.432)	20.0 (0.59)	26.5 (0.78)	—	217	317	417	517	617	717	817	917
0.019 (0.483)	28.0 (0.8)	36.3 (1.09)	—	219	319	419	519	619	719	819	919
0.021 (0.533)	35.0 (1.0)	45.4 (1.36)	—	—	321	421	521	621	721	821	921
‡0.023 (0.584)	40.0 (1.2)	51.9 (1.56)	—	—	—	423	523	623	723	—	923
‡0.025 (0.635)	50.0 (1.5)	64.8 (1.94)	—	—	—	425	525	625	725	825	—
‡0.027 (0.686)	58.5 (1.7)	75.8 (2.27)	—	—	—	—	527	627	—	827	—
‡0.029 (0.737)	68.0 (1.9)	88.2 (2.65)	—	—	—	—	—	629	—	—	—
‡0.031 (0.787)	78.0 (2.2)	101.1 (3.03)	—	—	—	431	—	631	—	—	—
‡0.033 (0.838)	88.0 (2.5)	114.1 (3.42)	—	—	—	—	—	633	—	—	—
‡0.035 (0.889)	98.0 (2.8)	127.1 (3.81)	—	—	—	435	—	—	—	—	—
‡0.037 (0.940)	108.0 (3.1)	140.0 (4.20)	—	—	—	—	—	—	737	—	—
‡0.039 (0.991)	118.0 (3.4)	153.0 (4.59)	—	—	—	—	539	639	—	839	—

*Tips are tested in water.

❖ Measured with NO airflow. Air assist will tend to reduce pattern lengths by 1 in. to 2 in.

‡Do not use these tips with PerformAA 15 gun models.

†150 mesh tip filter included.

Fluid output (Q) at other pressures (P) can be calculated by this formula: $Q = (0.041) (QT) \sqrt{P}$ where QT = fluid output (fl oz/min) from the above table for the selected orifice size.

Table 2: AXF Fine Finish Pre-Orifice Spray Tip Chart

Orifice Size in. (mm)	* Fluid Output 2000 psi (14.0 MPa, 140 bar) fl oz/min (lpm)		❖Maximum Pattern Width at 12 in. (305 mm) in. (mm)							
	at 600 psi (4.1 MPa, 41 bar)	at 1000 psi (7.0 MPa, 70 bar)	2 to 4 (75)	4 to 6 (150)	6 to 8 (200)	8 to 10 (250)	10 to 12 (300)	12 to 14 (350)	14 to 16 (400)	16 to 18 (450)
0.007 (0.178)	4.0 (0.1)	5.2 (0.15)	—	—	306	—	—	—	—	—
0.009 (0.229)	7.0 (0.21)	8.5 (0.25)	108	208	308	408	508	608	—	—
0.011 (0.279)	9.5 (0.28)	12.5 (0.37)	—	210	310	410	510	610	710	—
0.013 (0.330)	12.0 (0.35)	16.0 (0.47)	—	212	312	412	512	612	712	—
0.015 (0.381)	16.0 (0.47)	21.0 (0.62)	—	—	314	414	514	614	714	814
0.017 (0.432)	20.0 (0.59)	26.5 (0.78)	—	—	316	416	516	616	716	—
0.019 (0.483)	28.0 (0.8)	36.3 (1.09)	—	—	—	—	518	—	—	—

*Tips are tested in water.

❖ Measured with NO airflow. Air assist will tend to reduce pattern lengths by 1 in. to 2 in.

Fluid output (Q) at other pressures (P) can be calculated by this formula: $Q = (0.041) (QT) \sqrt{P}$
 where QT = fluid output (fl oz/min) from the above table for the selected orifice size.

PerformAA RAC SwitchTips

PerformAA RAC models are compatible with the following RAC spray tips:

LTX RAC Spray Tips (LTXxxx): Recommended for high pressure RAC spray gun models.

FFLP Fine Finish Low Pressure (FFLPxxx): Recommended for low pressure, fine finish applications for less over-spray and a consistent finish.

LTX and FFLP SwitchTips are the typical tips chosen, but the PerformAA RAC is also compatible with Low Pressure (LPxxxx) and Wide (WRxxxx) tips.

Order desired tip, where xxx = 3-digit spray tip Part No. from the matrix table. Example: Order LTX209 for the LTX RAC Spray tip with a 0.009 in. (0.229 mm) orifice and a maximum spray pattern of 2 to 4 in. (100 mm).

Convert PerformAA 50 models to a RAC Model with RAC Conversion Kit 26B722. Standard and acetal (solvent resistant) gasket kits are available. See **Reverse-a-Clean Kits**, page 59.



Orifice Size in. (mm)	* Fluid Output 2000 psi (14.0 MPa, 140 bar) fl oz/min (lpm)	❖ Maximum Pattern Width at 12 in. (305 mm) in. (mm)							
		2 to 4 (100)	4 to 6 (150)	6 to 8 (200)	8 to 10 (250)	10 to 12 (300)	12 to 14 (350)	14 to 16 (400)	16 to 18 (450)
LTX RAC Spray Tips									
0.009 (0.229)	11.2 (0.33)	109	209	309	409	509	—	—	—
0.011 (0.279)	16.6 (0.49)	111	211	311	411	511	611	—	—
0.013 (0.330)	23.3 (0.69)	—	213	313	413	513	613	—	—
0.015 (0.381)	30.8 (0.91)	115	215	315	415	515	615	—	—
0.017 (0.432)	39.5 (1.17)	—	217	317	417	517	617	—	817
0.019 (0.483)	49.7 (1.47)	—	219	319	419	519	619	—	819
0.021 (0.533)	60.5 (1.79)	—	221	321	421	521	621	721	821
0.023 (0.584)	72.7 (2.15)	—	—	323	423	523	623	723	—
0.025 (0.635)	85.9 (2.54)	—	225	325	425	525	625	—	—
0.027 (0.686)	100.0 (2.96)	—	227	327	427	527	627	—	827
0.029 (0.737)	115.6 (3.42)	—	—	329	429	529	629	729	—
0.031 (0.787)	131.8 (3.90)	—	231	331	431	531	631	—	831
0.033 (0.838)	149.4 (4.42)	—	—	—	433	533	633	—	833
0.035 (0.889)	168.4 (4.98)	—	235	335	435	535	635	735	835
FFLP Fine Finish Low Pressure RAC Spray Tips									
0.008 (0.203)	8.8 (0.26)	108	208	308	—	—	—	—	—
0.010 (0.254)	13.9 (0.41)	110	210	310	410	510	—	—	—
0.012 (0.305)	19.9 (0.59)	112	212	312	412	512	612	—	—
0.014 (0.356)	27.0 (0.80)	—	214	314	414	514	614	—	—
0.016 (0.406)	35.0 (1.04)	—	—	—	—	516	616	—	—
0.018 (0.457)	44.6 (1.32)	—	—	—	—	518	618	—	—
0.020 (0.51)	54.8 (1.62)	—	—	—	—	520	620	—	—

*Tips are tested in water.

❖Measured with NO airflow. Air assist will tend to reduce pattern lengths by 1 in. to 2 in.

Fluid output (Q) at other pressures (P) can be calculated by this formula: $Q = (0.041) (QT) \sqrt{P}$ where QT = fluid output (fl oz/min) from the above table for the selected orifice size.

Air Cap Selection Guide

				
<p>To reduce the risk of injury, follow the Pressure Relief Procedure, page 15, before removing or installing a tip and/or air cap.</p>				

Air caps are versatile, and more than one air cap can meet your finishing requirements. Select an air cap based on coating properties, finishing requirements, and operator preference.

Part No.	Color	Description	Typical Viscosity Range	Optimal Use Recommendations	HVLP Verification Kit
2GF042	PTFE Nickel	General Finishing (GF)	20-360 cP	Atomizes tails at lower pressures	2GF044
2WL042	Black	Wood Lacquer (WL)	20-360 cP	Spray wood finishing top coats and lacquer	2WL044
2WB042	Blue	Waterborne (WB)	20-360 cP	Break up the waterborne fluid stream for even wet film build with waterborne materials	2WB044
2LV042	Silver	Low Viscosity (LV)	20-70 cP	Promote dispersion of low viscosity materials	2LV044
2HV042	Blue Grey	High Viscosity (HV)	360+ cP	Build wet film with high solids materials	2HV044
2QD042	Green	Quick Drying (QD)	20-360 cP	Maintain transfer efficiency and minimize air bubbles with quick drying materials	2QD044
2TC042	PTFE Nickel	Top Coat (TC)	20-360 cP	Spray wood finishing top coats	2TC044
2AL042	Black	Airless (AL)	Not applicable	Airless spray application	---

Air Flow

See the **Air Cap Selection Guide** for part numbers.

General Finishing (GF), Wood Lacquer (WL), and Top Coat (TC) Air Caps

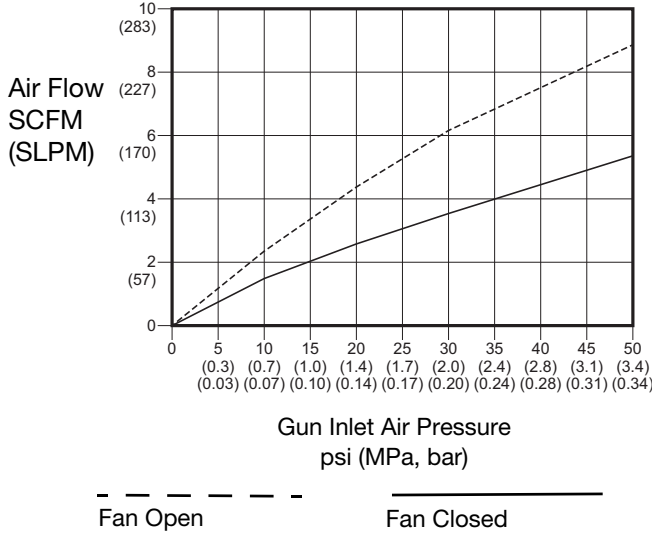

Quick Drying (QD) and High Viscosity (HV) Air Caps

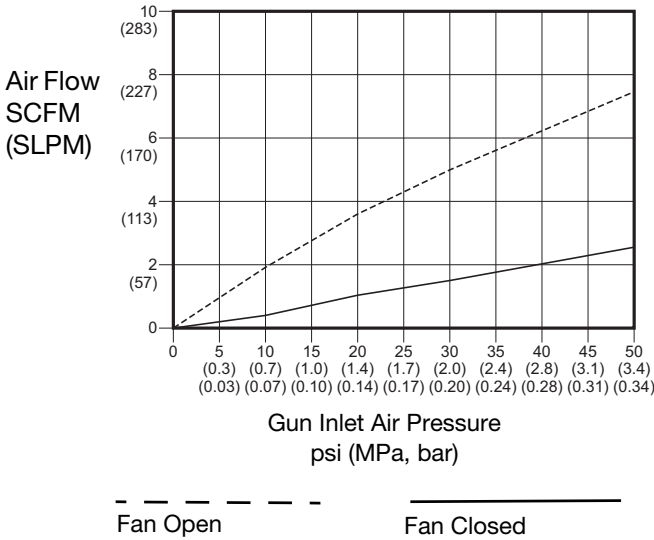

Low Viscosity (LV) and Waterborne (WB) Air Caps

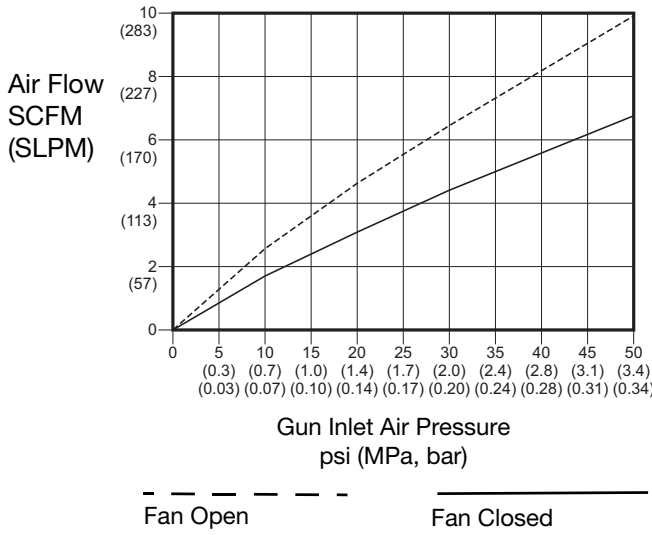

Kits and Accessories

Fluid Cartridge Repair Kits

Carbide Seat Repair Kits

26B707	Diffuser Replacement Kit, Carbide	housing, o-rings (3 sizes), nut, and carbide seat
26B710	Carbide Seat Repair Kit	nut, gasket (qty 2), and carbide seat
288619	Carbide Seat Gasket Kit	gaskets for carbide seat (10 pack)

Plastic Seat Repair Kits

26B708	Diffuser Replacement Kit, Plastic	housing, o-rings (3 sizes), nut, and plastic seat
249424	Plastic Seat Repair Kit	nut and plastic seat (10 pack)

Retaining Ring Kits

26B800	Retaining ring kit for PerformAA 1500 models	retaining ring, washer, o-ring
26B801	Retaining ring kit for PerformAA 5000 models	retaining ring with tip guard, washer, 2 o-rings
241812	Retaining ring seal kit	replacement washer and o-rings (5 pack of each)

Seal Kits

26B706	Fluid Seal Replacement Kit	replacement seals for the diffuser assembly, needle assembly, seat, and fluid tube
26B720	Fluid and Air Seal Repair Kit	Replacement fluid seals, air seals, and installation tool

Fluid Tube Repair Kits

26B711	Fluid Tube Assembly, with filter	fluid fitting, filter, tube, gasket, tube insert cartridge, and screw
26B712	High Flow Fluid Tube Assembly	tube, gasket, tube insert cartridge, and screw

Inline Fluid Filter Kits

238563	60 Mesh Inline Fluid Filters	replacement filters (3 pack)
238561	100 Mesh Inline Fluid Filters	replacement filters (3 pack)
25N892	150 Mesh Inline Fluid Filters	replacement filters (3 pack)
25N894	200 Mesh Inline Fluid Filters	replacement filters (3 pack)

Air Cartridge Kits

26B713	Air Cartridge Replacement Kit (with fan adjustment knob for air assist models)	air cartridge assembly, u-cup, and installation tool
26B717	Fixed Air Cartridge Assembly Kit (RAC and Airless models)	air cartridge assembly, u-cup, and installation tool
26B716	Air Valve Assembly Replacement Kit	air valve, u-cup and installation tool
26B715	Fan Tube Repair Kit (for air assist models)	fan tube, o-ring, and fan plug
26B915	Fan Tube Repair Kit (RAC and airless models)	o-ring and fan plug
26B714	Air Cartridge Repair Kit	air valve assembly, u-cup, installation tool, air cartridge o-rings, fan tube o-ring, and c-clip

Spray Tip Kits

26C713	Spray Tip Gasket Kit	replacement sealing washers (10 pack)
241804	Spray Tip Filter Kit	replacement filters for AXM spray tip orifice sizes 0.007, 0.009, and 0.011 (10 pack)

Reverse-a-Clean Kits

26B709	RAC Diffuser Replacement Kit	housing, o-rings (2 sizes), nut, and carbide seat
26B869	RAC Air Cap Assembly	air cap, retaining ring and tip housing
246453	RAC Gasket	replacement standard RAC gaskets (5 pack)
248936	Acetal RAC Gasket (solvent resistant)	plastic (acetal) replacement RAC gaskets (5 pack)
26B722✘	RAC Conversion Kit: AA to RAC AA	housing, air cap assembly, fluid cartridge, air cartridge, u-cup, and installation tool.
26B723✘	RAC Conversion Kit: Airless to RAC Airless	housing, air cap assembly, and fluid cartridge.
26B793✘	RAC Conversion Kit: RAC to Air Assist (5000 psi)	fluid cartridge, GF air cap assembly, air cartridge, u-cup, installation tool, and fan tube.
26B718	RAC Air Seal Repair Kit	air valve, u-cup seal, o-rings, and installation tool.

✘ Purchase tip separately.

Gun Part Kits

26B721	Trigger Repair Kit	trigger, trigger pin, and trigger nut
249423	Trigger Stop Kit	trigger stop and dowel pin
189018	Fluid Swivel Connector	5800 psi (40 MPa, 400 bar) maximum working pressure connector. 1/4-18 npsm. 17-4 PH stainless steel wetted parts
26B374	Fluid Swivel Connector, JIC	1/2-20 JIC fluid fitting; 5800 psi (40 MPa 400 bar) max working pressure connector
24C356	Fluid Fitting Kit	1/2-20 JIC threaded fluid inlet fitting

Cleaning Accessories

101892	Gun Brush
15C161	Ultimate Gun cleaning Kit
249598	Unclogging Needle Kit
15G093	PerformAA 15 Gun Flush Insert
15G346	PerformAA 50 Gun Flush Insert
111265	Gun Lubricant; 4 oz
15T544	O-Ring Pick

Air Quick Connect Fittings

26B727	Gun and Hose Connectors	100 psi (0.7 MPa, 7 bar) maximum working pressure
26B728	Gun Connector	9/16-18 unf thread; 100 psi (0.7 MPa, 7 bar) maximum working pressure
26B729	Hose Connector	1/4-18 npsm thread; 100 psi (0.7 MPa, 7 bar) maximum working pressure

Information Sign Accessories

19C703	Operation and Daily Care Quick Guide
19C704	Spray Gun Pattern Quick Guide
19C705	Spray Pattern Test Sheet (single)
19C706	Spray Pattern Test Sheet (Pack of 25)

System Accessories

249473	Air Fitting and Tubing Kit	3/8 in. to 1/4 push-to-lock fitting, 25 ft (7.62 m) long, nylon tubing
256389	Air Hose	1/4-18 npsm(fbe), 1/4 in. (6 mm) ID, 52 ft (15.85 m) long polyurethane tubing, 100 psi (0.7 MPa, 7 bar) max working pressure
256390	Air Hose	1/4-18 npsm(fbe), 1/4 in. (6 mm) ID, 27 ft (8.23 m) long polyurethane tubing, 100 psi (0.7 MPa, 7 bar) max working pressure
241812	Fluid Hose	3300 psi (2.2 MPa, 227 bar) maximum working pressure, 1/4-18 npsm(fbe), 3/16 in. (5 mm) ID, 25 ft (7.62 m) long, nylon tubing with polyurethane cover
24B562	Fluid Hose	3300 psi (2.27 MPa, 227 bar) maximum working pressure, 1/4-18 npsm(fbe), 3/16 in. (5 mm) ID, 50 ft (15.24 m) long, nylon tubing with polyurethane cover
24A446	Fluid Hose	4100 psi (2.8 MPa, 283 bar) maximum working pressure, 1/4-18 npsm(fbe), 1/4 in. (6.3 mm) ID, 23 ft (7.01 m) long, nylon tubing with polyurethane cover
24A412	Fluid Hose	5600 psi (3.8 MPa, 386 bar) maximum working pressure, 1/4-18 npsm(fbe), 1/4 in. (6.3 mm) ID, 25 ft (7.62 m) long, nylon tubing with polyurethane cover
24A413	Fluid Hose	5600 psi (3.8 MPa, 386 bar) maximum working pressure, 1/4-18 npsm(fbe), 1/4 in. (6.3 mm) ID, 50 ft (15.24 m) long, nylon tubing with polyurethane cover
26B598	Fluid Whip Hose	5000 psi (3.4 MPa, 345 bar) maximum working pressure, 1/4-18 npsm(fbe), 3/16 in. (4.8 mm) ID, 2 ft (0.6 m) long, nylon tubing with polyurethane cover
166846	Whip Hose Adapter	7250 psi (50 MPa, 500 bar) max working pressure whip hose adapter, 1/4-18 npsm x 1/4-18 npt (male).
238694	High Pressure Fluid Ball Valve	5000 psi (34.5 MPa, 345 bar) maximum working pressure, 3/8 npt (mbe), PTFE seals, stainless steel

Dimensions

Perform AA 15 Air Assist and Airless Gun Models	A	B	C	D	E
26B500, 26B501, 26B502, 26B503, 26B505, 26B504, 26B519*	6 in. (252.4 mm)	1.5 in. (38.1 mm)	8.2 in. (208.3 mm)	1/4-18 npsm (m)	1/4-18 npsm (R1/4-19) compound male thread

*dimension E does not apply

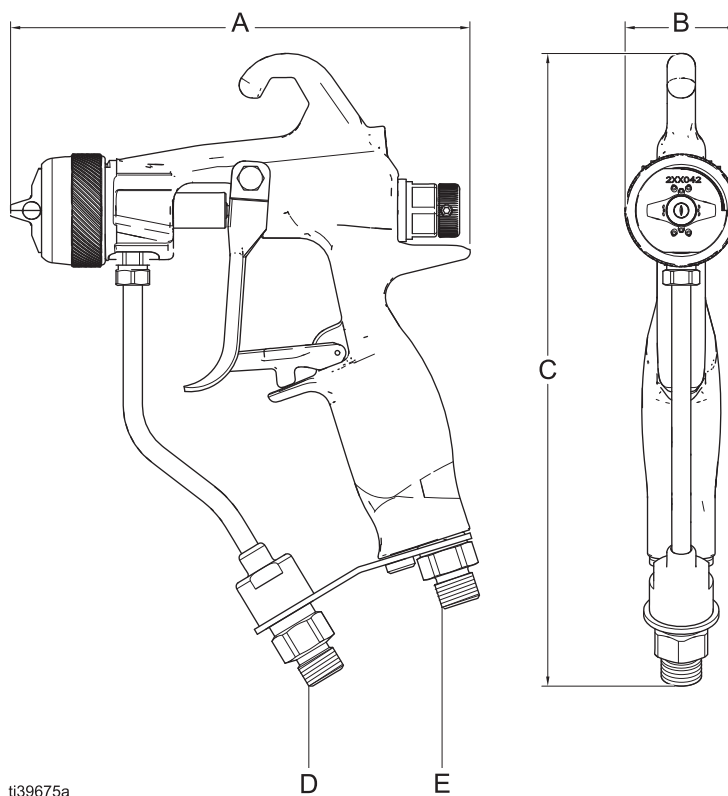

ti39675a

Dimensions

PerformAA 50 Air Assist and Airless Gun Models	A	B	C	D	E
26B510, 26B511, 26B512, 26B513, 26B514, 26B515, 26B516, 26B509, 26B520*	6.8 in. (172.7 mm)	2.2 in. (55.9 mm)	8.2 in. (208.3 mm)	1/4-18 npsm (m)	1/4-18 npsm (R1/4-19) compound male thread

*dimension E does not apply.

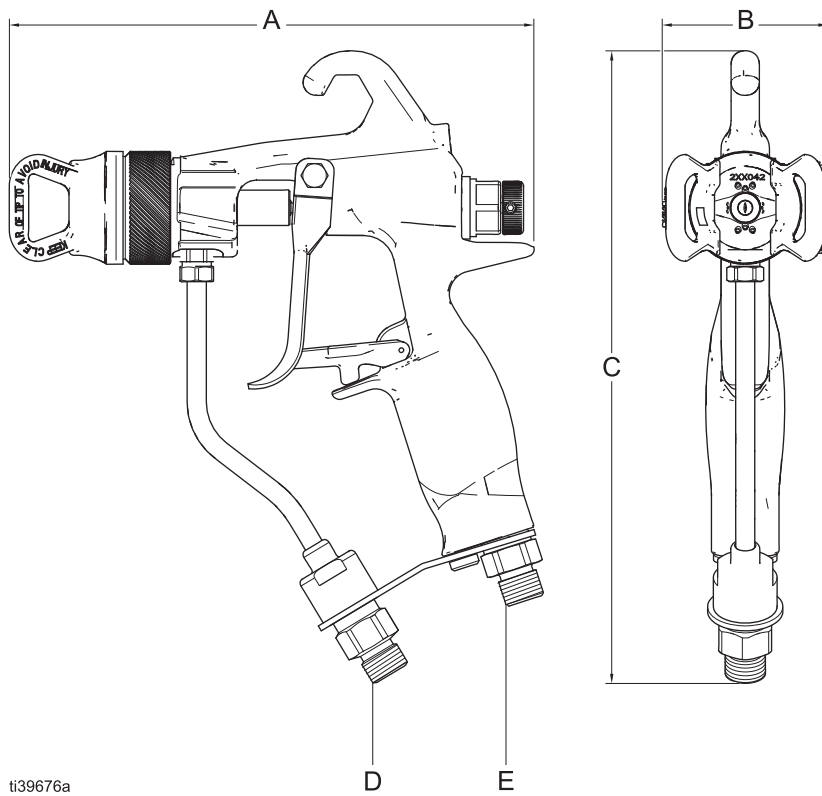

ti39676a

PerformAA RAC Air Assist Gun Models	A	B	C	D	E
26B517, 26B518	7.2 in. (182.9 mm)	2.8 in. (71.1 mm)	7.8 in. (198.1 mm)	1/4-18 npsm (m)	1/4-18 npsm (R1/4-19) compound male thread

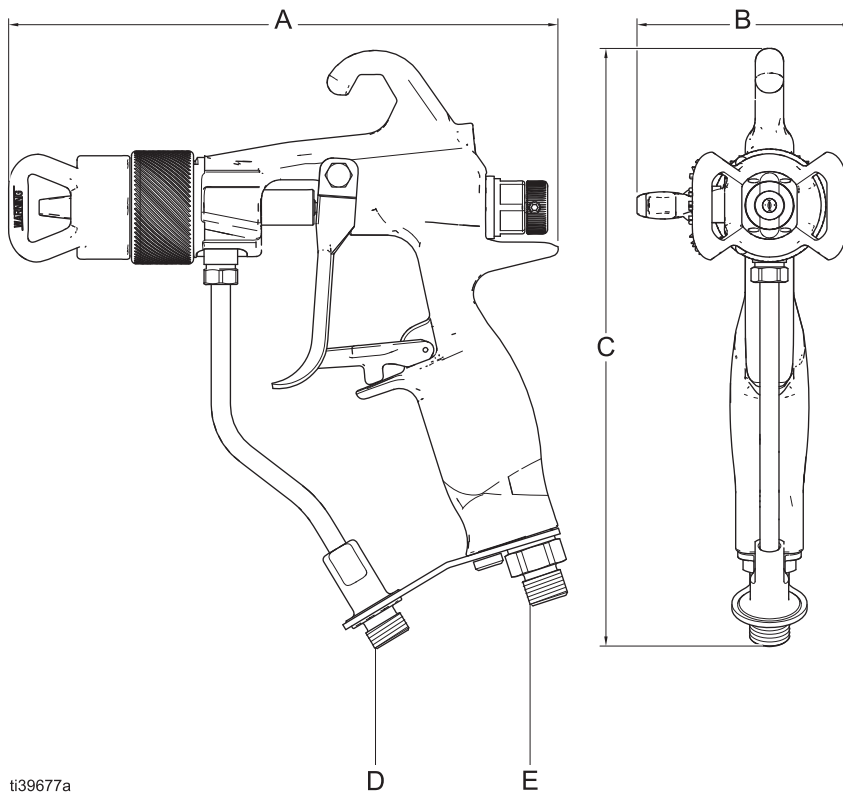

Technical Specifications

PerformAA Spray Guns		
	US	Metric
Maximum working fluid pressure		
PerformAA 15 air assist models	1500 psi	10.5 MPa, 105 bar
PerformAA 50 air assist models	5000 psi	34.5 MPa, 345 bar
Perform AA RAC air assist models	5000 psi	34.5 MPa, 345 bar
PerformAA airless model 26B519	1500 psi	10.5 MPa, 105 bar
PerformAA airless model 26B520	5000 psi	34.5 MPa, 345 bar
Maximum working air pressure	100 psi	0.7 MPa, 7 bar
Maximum fluid temperature	110°F	43°C
Noise (dBa)		
Sound pressure at 20 psi (138 kPa, 1.4 bar)	62.6 dBa	
Sound pressure at 100 psi (0.7 MPa, 7 bar)	75.8 dBa	
Sound power at 20 psi (138 kPa, 1.4 bar)	72.3 dBa	
Sound power at 100 psi (0.7 MPa, 7 bar)	89.3 dBa	
<i>All readings were taken with the fan valve fully closed (full fan size), at 20 psi (138 kPa, 1.4 bar) and 100 psi (0.7 MPa, 7 bar), and at the assumed operator position.</i>		
<i>Sound power measured per ISO-9614-2.</i>		
Inlet/Outlet Sizes		
Air inlet size	1/4-18 npsm (R1/4-19) compound male thread	
Fluid inlet size	1/4-18 npsm (m)	
Materials of Construction		
Wetted materials: all models except 26B504	Stainless Steel, Carbide, Ultra High Molecular Weight Polyethylene, Engineered Plastic, PTFE, Nylon, Fluoroelastomer	
Wetted materials: model 26B504	Stainless Steel, Ultra High Molecular Weight Polyethylene, Engineered Plastic, PTFE, Nylon, Fluoroelastomer	
Weight		
PerformAA 15 models	17.1 oz	480 grams
PerformAA 50 models	17.4 oz	490 grams

California Proposition 65

CALIFORNIA RESIDENTS

 **WARNING:** Cancer and reproductive harm – www.P65warnings.ca.gov.

Graco Standard Warranty

Graco warrants all equipment referenced in this document which is manufactured by Graco and bearing its name to be free from defects in material and workmanship on the date of sale to the original purchaser for use. With the exception of any special, extended, or limited warranty published by Graco, Graco will, for a period of twelve months from the date of sale, repair or replace any part of the equipment determined by Graco to be defective. This warranty applies only when the equipment is installed, operated and maintained in accordance with Graco's written recommendations.

This warranty does not cover, and Graco shall not be liable for general wear and tear, or any malfunction, damage or wear caused by faulty installation, misapplication, abrasion, corrosion, inadequate or improper maintenance, negligence, accident, tampering, or substitution of non-Graco component parts. Nor shall Graco be liable for malfunction, damage or wear caused by the incompatibility of Graco equipment with structures, accessories, equipment or materials not supplied by Graco, or the improper design, manufacture, installation, operation or maintenance of structures, accessories, equipment or materials not supplied by Graco.

This warranty is conditioned upon the prepaid return of the equipment claimed to be defective to an authorized Graco distributor for verification of the claimed defect. If the claimed defect is verified, Graco will repair or replace free of charge any defective parts. The equipment will be returned to the original purchaser transportation prepaid. If inspection of the equipment does not disclose any defect in material or workmanship, repairs will be made at a reasonable charge, which charges may include the costs of parts, labor, and transportation.

THIS WARRANTY IS EXCLUSIVE, AND IS IN LIEU OF ANY OTHER WARRANTIES, EXPRESS OR IMPLIED, INCLUDING BUT NOT LIMITED TO WARRANTY OF MERCHANTABILITY OR WARRANTY OF FITNESS FOR A PARTICULAR PURPOSE.

Graco's sole obligation and buyer's sole remedy for any breach of warranty shall be as set forth above. The buyer agrees that no other remedy (including, but not limited to, incidental or consequential damages for lost profits, lost sales, injury to person or property, or any other incidental or consequential loss) shall be available. Any action for breach of warranty must be brought within two (2) years of the date of sale.

GRACO MAKES NO WARRANTY, AND DISCLAIMS ALL IMPLIED WARRANTIES OF MERCHANTABILITY AND FITNESS FOR A PARTICULAR PURPOSE, IN CONNECTION WITH ACCESSORIES, EQUIPMENT, MATERIALS OR COMPONENTS SOLD BUT NOT MANUFACTURED BY GRACO. These items sold, but not manufactured by Graco (such as electric motors, switches, hose, etc.), are subject to the warranty, if any, of their manufacturer. Graco will provide purchaser with reasonable assistance in making any claim for breach of these warranties.

In no event will Graco be liable for indirect, incidental, special or consequential damages resulting from Graco supplying equipment hereunder, or the furnishing, performance, or use of any products or other goods sold hereto, whether due to a breach of contract, breach of warranty, the negligence of Graco, or otherwise.

FOR GRACO CANADA CUSTOMERS

The Parties acknowledge that they have required that the present document, as well as all documents, notices and legal proceedings entered into, given or instituted pursuant hereto or relating directly or indirectly hereto, be drawn up in English. Les parties reconnaissent avoir convenu que la rédaction du présente document sera en Anglais, ainsi que tous documents, avis et procédures judiciaires exécutés, donnés ou intentés, à la suite de ou en rapport, directement ou indirectement, avec les procédures concernées.

Graco Information

For the latest information about Graco products, visit www.graco.com.

For patent information, see www.graco.com/patents.

TO PLACE AN ORDER, contact your Graco distributor or call to identify the nearest distributor.

Phone: 612-623-6921 **or Toll Free:** 1-800-328-0211, **Fax:** 612-378-3505

All written and visual data contained in this document reflects the latest product information available at the time of publication. Graco reserves the right to make changes at any time without notice.

Original instructions. This manual contains English. MM 3A8099

Graco Headquarters: Minneapolis

International Offices: Belgium, China, Japan, Korea

GRACO INC. AND SUBSIDIARIES • P.O. BOX 1441 • MINNEAPOLIS MN 55440-1441 • USA
Copyright 2021, Graco Inc. All Graco manufacturing locations are registered to ISO 9001.

www.graco.com
Revision C, July 2023