



MAGNUM[®] TRUEAIRLESS[®]

Electric Airless Sprayer

OWNERS MANUAL PROX19 CORDLESS

3A9019C EN

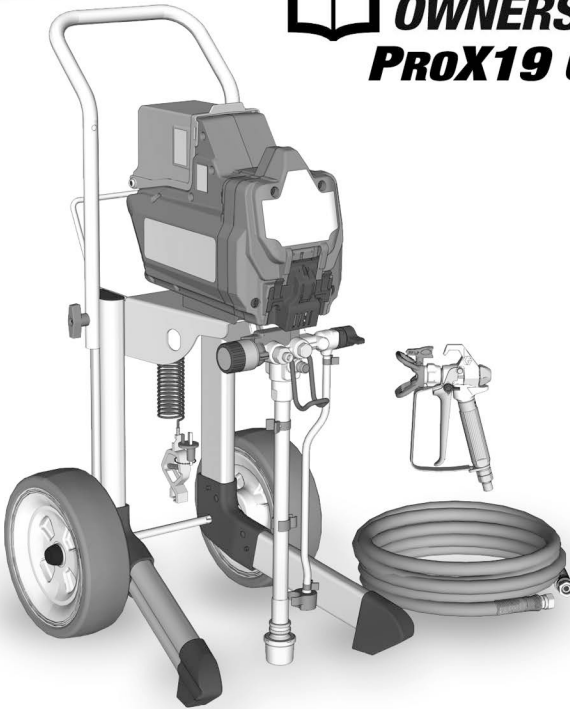

940783a



Important Safety Instructions

Read all warnings and instructions in this manual, related manuals, and on the unit, before using the equipment. Be familiar with the controls and the proper usage of the equipment. Save these instructions.



Magnum Products Operational Videos
<http://magnum.graco.com/magop/>

***For portable spray applications of architectural paints and coatings only.
Not approved for use in explosive atmospheres or hazardous (classified) locations.***

 SERVICE <small>To every customer, every time</small>	Questions? 888-541-9788	
	http://magnum.graco.com/magop/	

PROVEN QUALITY. LEADING TECHNOLOGY.

Before You Spray

Before You Spray

Review Warnings for Important Safety Information

Important! Read carefully and practice good safety habits.



Magnum Products Operational Videos
<http://magnum.graco.com/magop/>

Related Manuals

312830	SG Spray Guns
3A3172	ProXChange™ Pump

Models

3000 psi (207 bar, 20.7 MPa) Maximum Working Pressure

	Charger Voltage (VAC)	Model	Cart
 110474 Certified to CAN/CSA C22.2 No. 68 Conforms to UL 1450	120	ProX19	25U478
			CAN478

Online Resources

Visit Our Website:	magnum.graco.com
Operational Videos:	magnum.graco.com/magop/
Manuals:	magnum.graco.com/support/#manuals
Parts Online:	magnum.graco.com/partsonline/

TheProX19 is compatible with the following DEWALT® FLEXVOLT 60V batteries:

- DCB606 - 60V/2ah (20V/6ah)
- DCB609 - 60V/3ah (20V/9ah)
- DCB612 - 60V/4ah (20V/12ah)

Related DEWALT Manuals

Manual	Description	Region
N463494	DEWALT DCB118 Fast Charger Manual	USA/CA

Contents

Before You Spray	2
Contents	3
Important Grounding Information	4
Warnings	5
Know Your Sprayer	7
ProX19 Cart Sprayer	7
Know Your Controls	9
Grounding Instructions	10
(Oil-Based or Flammable Materials)	10
Pails	10
Setup	12
Battery Installation and Removal	13
Start Up	14
Pressure Relief Procedure	14
Flush Storage Fluid	15
Strain the Paint	16
Fill Pump (Prime Pump)	16
Fill Gun and Hose	17
Refill Paint Pail	18
Blockages	18
Spraying	19
Start	19
Adjust Pressure Control	19
Spray Pattern Quality	19
Spray Techniques	20
Trigger the Gun	20
Aim Gun	20
Align Spray Pattern	20
Spray Tip and Pressure Selection	22
Clear Spray Tip Clog	23
Spray Tip Installation	23
Cleanup	25
Clean from a Pail	25
Cleanup with Power Flush Valve	27
Clean InstaClean Filter	29
Clean the Gun and Gun Filter	29

Contents

Storage	30
Short Term Storage	30
Long Term Storage	30
Reference	32
Lacquer Conversion Kit	32
Cleaning Fluid Compatibility	32
Quick Reference	33
Maintenance	34
Airless Hoses	34
Spray Tips	34
Storage/Priming Tool	34
Inlet Valve Removal	35
Pump Repair	36
Troubleshooting	38
ProX19 Cordless Cart Sprayer Parts	43
ProX19 Cordless Cart Sprayer Parts List	44
ProXChange Pump Parts	45
ProXChange Pump Parts List	46
Wiring Diagram - 60VDC	47
Technical Specifications	48
Graco Standard Warranty	49
Graco Information	50



Important Grounding Information

Important Grounding Information

The following information is intended to help you understand when to use the grounding wire and clamp provided with your sprayer.

Please read the information on the material container label to determine if it is oil-based or flammable. Ask for a Safety Data Sheet (SDS) from your supplier. The container label and SDS will explain the contents of the material and the specific precautions related to it.

Paints, coatings and clean-up materials generally fit into one of the following **3 basic types**:

Grounding Wire and Clamp Required?	Type of Material
No	WATER-BASED: The container label should indicate that the material can be cleaned up with soap and water.
Yes 	OIL-BASED: The container label should indicate that the material is COMBUSTIBLE and can be cleaned up with mineral spirits or non-flammable paint thinner. Use oil-based material outdoors or in a well-ventilated indoor area with a flow of fresh air. See the safety warnings in this manual. Follow Grounding Instructions , page 11, when using this type of material.
Yes 	FLAMMABLE: This type of material contains flammable solvents such as xylene, toluene, naphtha, MEK, lacquer thinner, acetone, denatured alcohol, and turpentine. The container label should indicate that this material is FLAMMABLE. Use flammable materials outdoors or in a well-ventilated area with a flow of fresh air. Follow Grounding Instructions , page 11, when using this type of material.

NOTE: To spray flammable materials, you must install the **Lacquer Conversion Kit**, page 32.

Warnings

The following warnings are for the setup, use, grounding, maintenance, and repair of this equipment. The exclamation point symbol alerts you to a general warning and the hazard symbols refer to procedure-specific risks. When these symbols appear in the body of this manual or on warning labels, refer back to these Warnings. Product-specific hazard symbols and warnings not covered in this section may appear throughout the body of this manual where applicable.

WARNING



FIRE AND EXPLOSION HAZARD

Flammable fumes, such as solvent and paint fumes, in work area can ignite or explode. To help prevent fire and explosion:



- Do not spray flammable or combustible materials near an open flame or sources of ignition such as cigarettes, motors, and electrical equipment.



- Do not use a paint or a solvent containing halogenated hydrocarbons.



- Keep spray area well-ventilated. Keep a good supply of fresh air moving through the area.
- Sprayer generates sparks. Keep pump assembly in a well-ventilated area at least 20 feet (6.1 m) from the spray area when spraying, flushing, cleaning, or servicing. Do not spray pump assembly.

- Do not smoke in the spray area or spray where sparks or flame is present.

- Do not operate light switches, engines, or similar spark producing products in the spray area.

- Keep area clean and free of paint or solvent containers, rags, and other flammable materials.

- Know the contents of the paints and solvents being sprayed. Read all Safety Data Sheets (SDSs) and container labels provided with the paints and solvents. Follow the paint and solvent manufacturer's safety instructions.

- Keep a working fire extinguisher in the work area.

Oil-based or Flammable Materials

Paint or solvent flowing through the equipment is able to result in static electricity. Static electricity creates a risk of fire or explosion in the presence of paint or solvent fumes. To help prevent fire and explosion when using oil-based or flammable materials:

- Connect the grounding wire and clamp to a true earth ground.

- If there is static sparking or if you feel a shock, stop operation immediately. Do not use sprayer until you identify and correct the problem.

- All parts of the spray system, including the pump, hose assembly, spray gun, and objects in and around the spray area shall be properly grounded to protect against static discharge and sparks. Use Graco conductive or grounded high-pressure airless paint sprayer hoses. Follow **Grounding Instructions**, page 11.

- Verify that all containers and collection systems are grounded to prevent static discharge. Do not use pail liners unless they are anti-static or conductive.

WARNING



SKIN INJECTION HAZARD

High-pressure spray is able to inject toxins into the body and cause serious injury that can result in amputation. In the event that injection occurs, **get immediate surgical treatment.**



- Do not aim the gun at, or spray any person or animal.
- Keep hands and other body parts away from the discharge. For example, do not try to stop leaks with any part of the body.
- Always use the spray tip guard. Do not spray without spray tip guard in place.
- Use Graco spray tips.
- Use caution when cleaning and changing spray tips. In the case where the spray tip clogs while spraying, follow the **Pressure Relief Procedure** for turning off the unit and relieving the pressure before removing the spray tip to clean.
- Equipment maintains pressure after power is shut off. Do not leave the equipment energized or under pressure while unattended. Follow the **Pressure Relief Procedure** when the equipment is unattended or not in use, and before servicing, cleaning, or removing parts.
- Check hoses and parts for signs of damage. Replace any damaged hoses or parts.
- This system is capable of producing 3000 psi (207 bar, 20.7 MPa). Use Graco parts or accessories that are rated a minimum of 3000 psi (207 bar, 20.7 MPa).
- Always engage the trigger lock when not spraying. Verify the trigger lock is functioning properly.
- Verify that all connections are secure before operating the unit.
- Know how to stop the unit and bleed pressure quickly. Be thoroughly familiar with the controls.



EQUIPMENT MISUSE HAZARD

Misuse can cause death or serious injury.



- Always wear appropriate gloves, eye protection, and a respirator or mask when spraying.
- Do not operate or spray near children. Keep children away from equipment at all times.
- Do not overreach or stand on an unstable support. Keep effective footing and balance at all times.
- Stay alert and watch what you are doing.
- Do not operate the unit when fatigued or under the influence of drugs or alcohol.
- Do not kink or over-bend the hose.
- Do not expose the hose to temperatures or to pressures in excess of those specified by Graco.
- Do not use the hose as a strength member to pull or lift the equipment.
- Do not spray with a hose shorter than 25 feet.
- Always replace cracked, broken or missing parts immediately with genuine Graco parts. See **Parts**, page 43.
- Do not alter or modify equipment. Alterations or modifications may void agency approvals and create safety hazards.
- Use only in dry locations. Do not expose to water or rain.
- Use in well-lit areas.
- Make sure all equipment is rated and approved for the environment in which you are using it.
- Do not operate or clean sprayer with the battery shield open.

Warnings

WARNING



PRESSURIZED ALUMINUM PARTS HAZARD

Use of fluids that are incompatible with aluminum in pressurized equipment can cause serious chemical reaction and equipment rupture. Failure to follow this warning can result in death, serious injury, or property damage.

- Do not use 1,1,1-trichloroethane, methylene chloride, other halogenated hydrocarbon solvents or fluids containing such solvents.
- Do not use chlorine bleach.
- Many other fluids may contain chemicals that can react with aluminum. Contact your material supplier for compatibility.



BATTERY AND CHARGER COMPATIBILITY HAZARD



- Only use DEWALT brand 60V Max batteries and battery chargers with this tool.
- READ ALL INSTRUCTIONS included with this tool regarding the safety and usage of DEWALT batteries and battery chargers.
- Do not wash or spray down battery.
- Do not clean the battery with anything other than a cloth moistened with water.



MOVING PARTS HAZARD

Moving parts can pinch, cut, or amputate fingers and other body parts.



- Keep clear of moving parts.
- Do not operate equipment with protective guards or covers removed.
- Equipment can start without warning. Before checking, moving, or servicing equipment, follow the **Pressure Relief Procedure** and disconnect all power sources.



TOXIC FLUID OR FUMES HAZARD

Toxic fluids or fumes can cause serious injury or death if splashed in the eyes or on skin, inhaled, or swallowed.

- Read Safety Data Sheets (SDSs) to know the specific hazards of the fluids you are using.
- Store hazardous fluid in approved containers, and dispose of it according to applicable guidelines.



PERSONAL PROTECTIVE EQUIPMENT

Wear appropriate protective equipment when in the work area to help prevent serious injury, including eye injury, hearing loss, inhalation of toxic fumes, and burns. Protective equipment includes but is not limited to:

- Protective eyewear, and hearing protection.
- Respirators, protective clothing, and gloves as recommended by the fluid and solvent manufacturer.

Know Your Sprayer

ProX19 Cart Sprayer

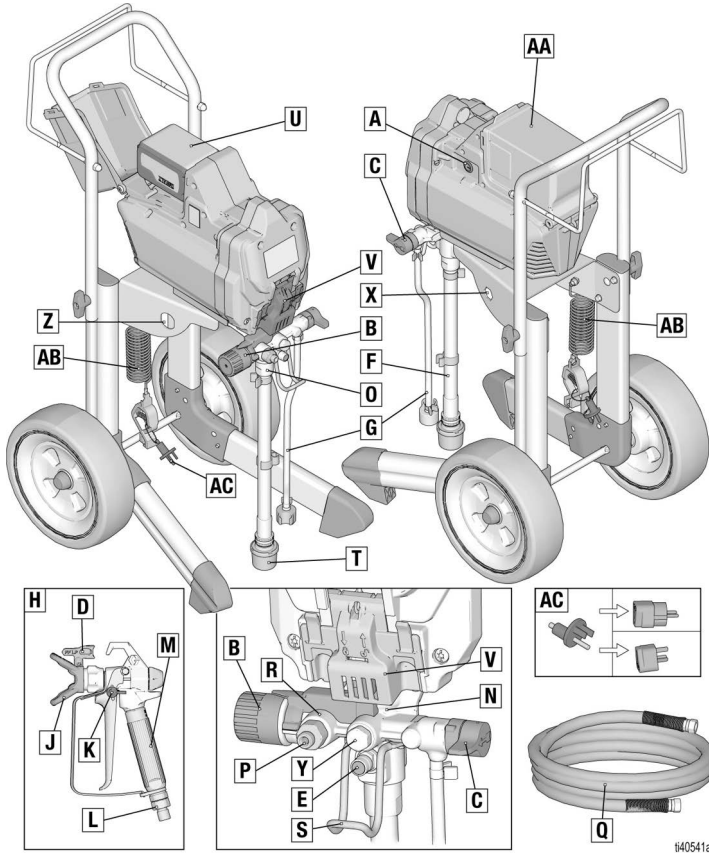

A	Power - ON/OFF Switch
B	Pressure Control Knob
C	Prime/Spray Valve
D	Spray Tip
E	PushPrime Button
F	Suction Tube
G	Drain Tube (with diffuser)
H	Airless Spray Gun
J	Spray Tip Guard
K	Gun Trigger Lock
L	Gun Fitting
M	Gun Filter (inside handle)
N	ProXChange™ Pump (behind Easy Access Door)
O	Inlet Valve
P	Airless Hose Connection

Q	Airless Hose
R	InstaClean™ Filter (inside fluid outlet)
S	Pail Hanger
T	Inlet Screen
U	Battery
V	Easy Access Door
X	Pump Removal Tool
Y	Outlet Valve
Z	Inlet Valve Removal Tool
AA	Battery Cover
AB	Ground Wire w/ Clamp
AC	Outlet Ground Adapter
	Model/Serial Tag (Not shown, located on bottom of unit.)
See Quick Reference , page 33 for more information.	

Know Your Controls

Know Your Controls

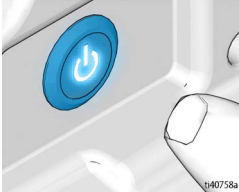
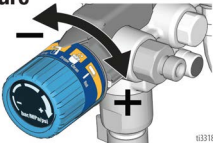
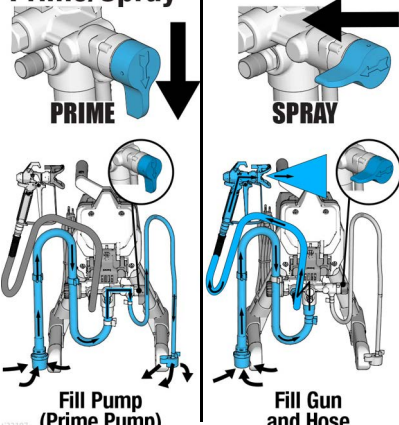
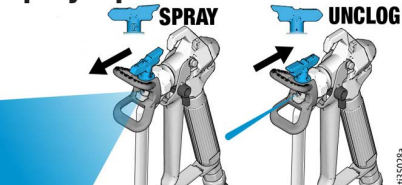
<p>Power</p>  <p>ti40758a</p>	<p>The ON/OFF power switch controls the main power to your sprayer. The power button is illuminated when ON.</p>
<p>Pressure</p>  <p>ti33186a</p>	<p>The Pressure Control knob increases or decreases the pressure and flow of the paint.</p>
<p>Prime/Spray</p>  <p>ti33187a</p>	<p>The Prime/Spray Valve directs the fluid to either the Drain Tube or the hose and gun. It is used to prime the sprayer, which means to evacuate the air out of the pump, hose, and gun.</p> <p>Your gun will not spray if there is air in the system. It is necessary to prime the pump, hose, and gun any time air enters the Suction Tube.</p>
<p>Spray Tip</p>  <p>ti33028a</p>	<p>The Spray Tip is the key to airless spray technology. High pressure paint pumped through the very small hole in the Spray Tip comes out as a spray.</p> <p>The Spray Tip has the ability to be reversed and quickly clear clogs.</p>

Grounding Instructions

(Oil-Based or Flammable Materials)



The equipment must be grounded to reduce the risk of static sparking. A static spark can cause fumes to ignite or explode. A good ground provides an escape wire for the electric current.

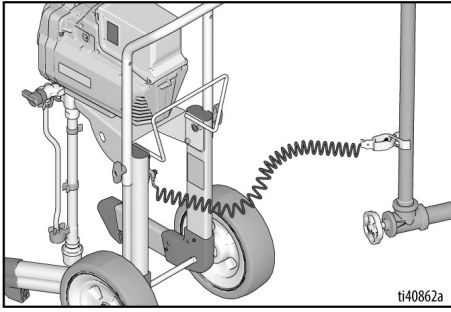

The sprayer is equipped with a grounding wire and clamp. The clamp must be connected to a true earth ground when spraying or flushing oil-based or flammable materials, see **Important Grounding Information**, page 5.

A water pipe can be used as a true earth ground. Connect the grounding wire and clamp to a metal water pipe.

A properly grounded electrical outlet can also be used as a true earth ground. Use the provided outlet adapter.

Plug the adapter in to a grounded outlet. Connect the grounding wire and clamp to the metal stud on the adapter. If the ground wire is not long enough to reach a grounded electrical outlet, use a 3-wire grounded extension cord between the adapter and outlet.

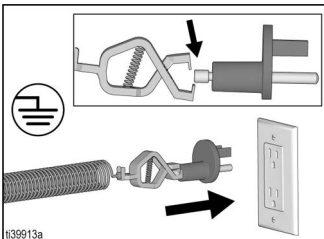

Fluid hoses: Use only electrically conductive hoses with a maximum of 300 ft. (91 m) combined hose length to ensure grounding continuity.

Spray gun: Grounded through connection to a properly grounded fluid hose and pump.

Pails

Oil-based or flammable fluids: follow local codes and regulations. Use only conductive metal pails, placed on a grounded surface such as concrete.

Do not place pail on a non-conductive surface such as paper or cardboard which interrupts grounding continuity.



Always ground a metal pail: connect a ground wire to the pail. Clamp one end to the pail and the other end to a true earth ground such as a water pipe.

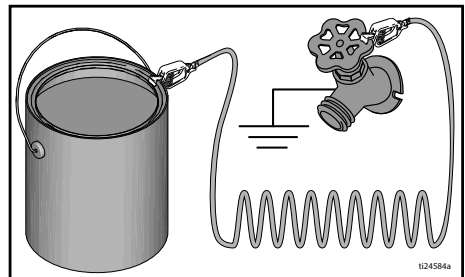

Grounding Instructions

To maintain ground continuity when sprayer is flushed or pressure is relieved: hold metal part of spray gun firmly to the side of a grounded metal pail then trigger the gun.

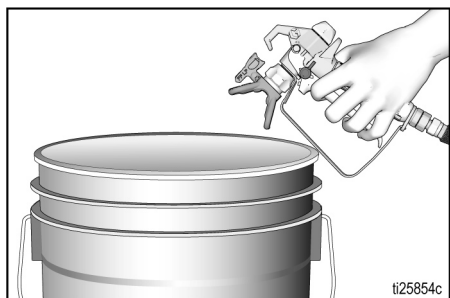

Setup

Assemble Your Sprayer

1. Connect airless hose to airless hose connection (P) on sprayer. Use wrench to tighten securely.
2. Connect the other end of the hose to the gun. Use two wrenches to tighten securely to gun (see image below).

NOTE: It is important to use two wrenches when connecting the hose to the gun, both for ease of installation and to ensure a tight connection.

If hose is already connected, make sure connections are tight.

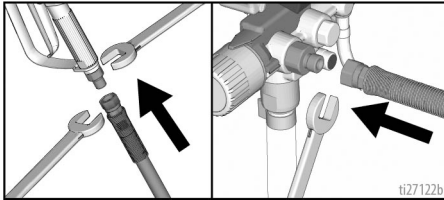

3. Assure Spray Tip is properly inserted into the Spray Tip Guard, and the Spray Tip Guard assembly is tightened securely to gun. See **Spray Tip Installation**, page 23.

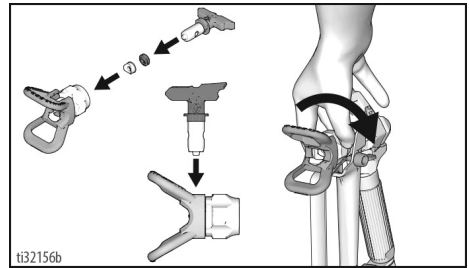

Setup

Battery Installation and Removal

Always start with a fully charged battery. Do not splash or immerse battery or charger in water. See battery and charger information shipped with the sprayer.



Replace and charge battery only in a well-ventilated area and away from flammable or combustible materials, including paints and solvents.

Remove and install battery into the sprayer as follows:

1. Remove the used battery, if in place.

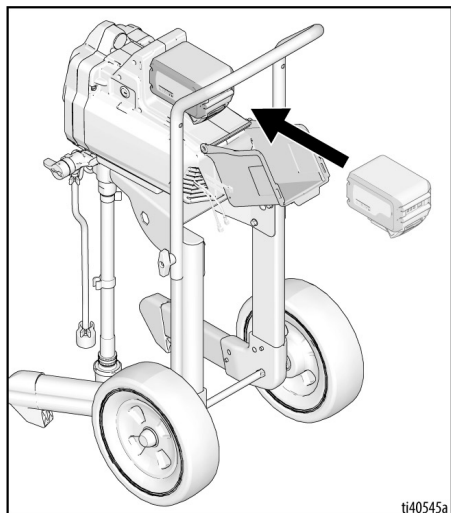

ti40545a

2. Install battery by aligning the battery pack with the rails inside the sprayer and sliding it in until the battery pack is firmly seated. Ensure that it does not disengage.

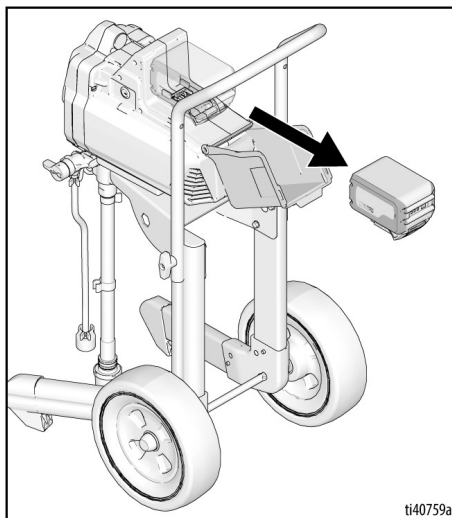

ti40759a

Start Up

Pressure Relief Procedure



Follow the Pressure Relief Procedure whenever you see this symbol.

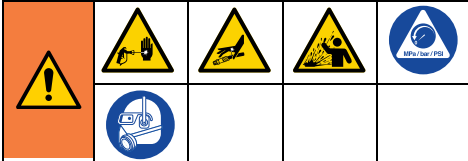

This equipment stays pressurized until pressure is manually relieved. To help prevent serious injury from pressurized fluid, such as skin injection or splashed fluid, follow the **Pressure Relief Procedure** whenever sprayer is stopped and before sprayer is cleaned or checked, and before equipment is serviced.

1. Engage the trigger lock. Always engage the trigger lock when sprayer is stopped to prevent the gun from being triggered accidentally.

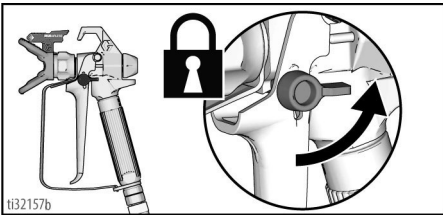

2. Turn ON/OFF switch to the **OFF** position. Button is not illuminated when OFF.

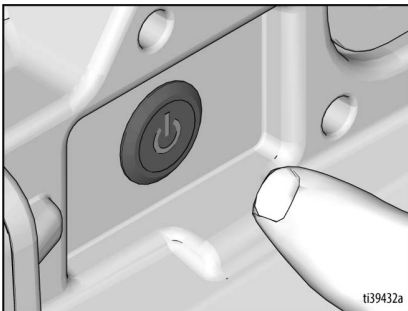

3. Turn pressure control knob to lowest setting.

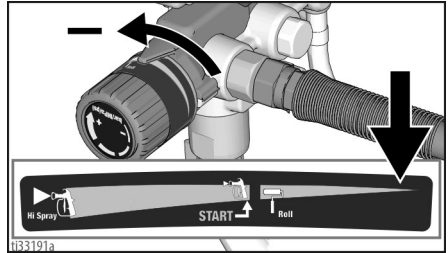

4. Put Drain Tube into a waste pail and turn Prime/Spray Valve down to PRIME position to relieve pressure.

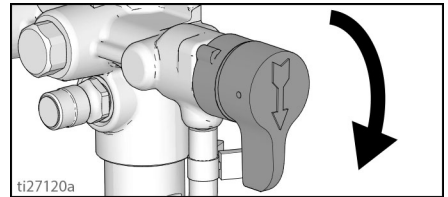

5. Hold the gun firmly to a pail. Point gun into pail. Disengage the trigger lock and trigger the gun to relieve pressure.

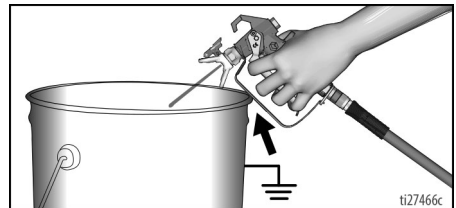

6. Engage the trigger lock.

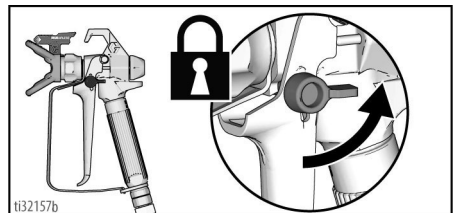

7. If you suspect that pressure has not been fully relieved, see **Blockages**, page 19.

NOTE: Leave Prime/Spray Valve in the PRIME position until you are ready to spray.

Flush Storage Fluid

It is important that you flush storage fluid from the sprayer before using it.

1. Make certain ON/OFF switch is **OFF**. Button is not illuminated when OFF.
2. Separate Drain Tube (smaller) from Suction Tube (larger). Place Drain Tube in a waste pail.
3. Submerge Suction Tube into pail filled with water if spraying water-based material, or mineral spirits or compatible flushing solvents if spraying oil-based or flammable material. When flushing oil-based or flammable materials, follow **Grounding Instructions**, page 11.

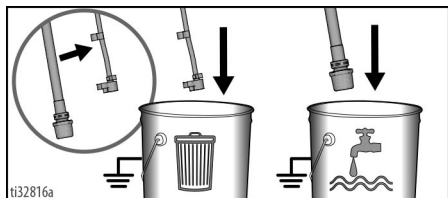

4. Turn Prime/Spray Valve down to **PRIME** position.

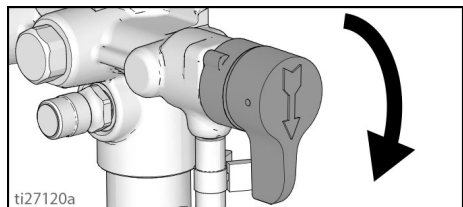

5. Install battery, see **Battery Installation and Removal**, page 14.
6. Press the PushPrime button twice to loosen Inlet Valve ball.

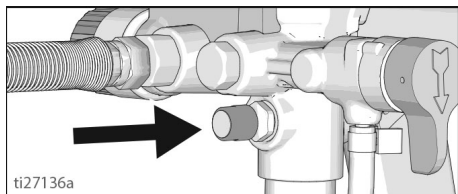

7. Align setting indicator with the **START** setting on the pressure control knob.

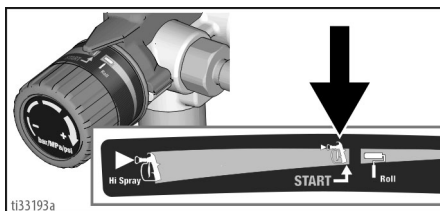

8. Turn ON/OFF switch to **ON** position. Button is illuminated when ON.

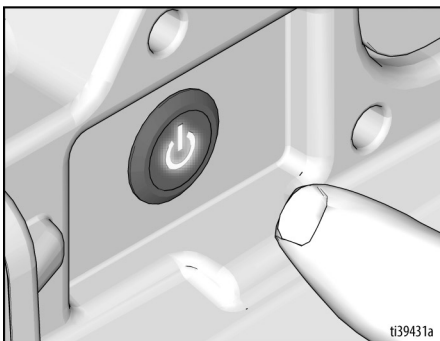

9. When sprayer starts pumping, flushing fluid will flow up the Suction Tube and out the Drain Tube. Allow fluid to flow out of Drain Tube, into waste pail, for 30 to 60 seconds.

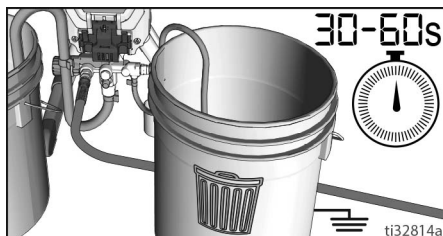

- Turn the ON/OFF switch to **OFF** position. Button is not illuminated when OFF.

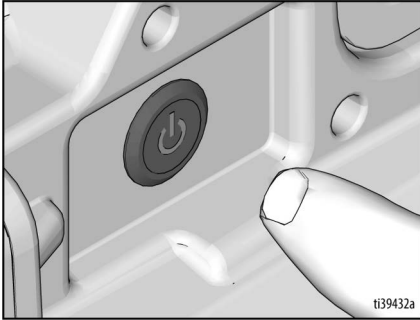

NOTE: If flushing fluid fails to come out of the Drain Tube, see **Storage/Priming Tool**, page 34.

Strain the Paint

Disposable paint strainer bags are used to remove coarse particles and debris from new or previously opened paint or stain, and are available where paint is sold. To avoid priming problems and Spray Tip clogs it is recommended to strain all paints and stains before spraying. Stretch a disposable paint strainer bag over a clean pail and pour the paint through the strainer.



Fill Pump (Prime Pump)

The Prime/Spray Valve directs the fluid to either the Drain Tube or the hose and gun. It is used to prime the sprayer, which means to evacuate the air out of the pump, hose, and gun.

Your gun will not spray if there is air in the system. It is necessary to prime the pump, hose, and gun any time air enters the suction tube.

- Move Suction Tube to paint pail and submerge Suction Tube in paint. When spraying oil-based or flammable materials, follow **Grounding Instructions**, page 11.

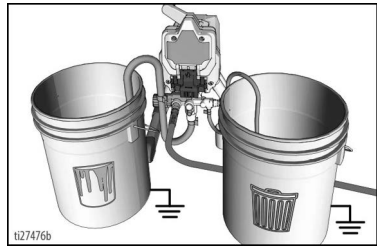

- Turn ON/OFF switch to **ON** position.
- Wait to see paint coming out of Drain Tube.
- Turn ON/OFF switch to **OFF** position.

NOTE: If paint does NOT flow up the Suction Tube and out the Drain Tube, see **Flush Storage Fluid**, page 16.

Start Up

Fill Gun and Hose

1. Rotate Spray Tip to UNCLOG position and ensure the Spray Tip Guard is tight.

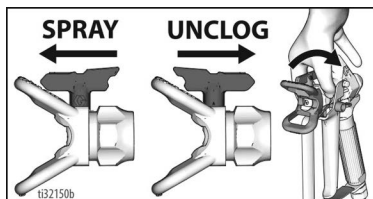

2. Hold gun against waste pail. Point gun into waste pail.

- a. Disengage trigger lock (A).
- b. Pull and hold gun trigger (B).
- c. Turn Prime/Spray Valve horizontal to SPRAY position (C).
- d. Turn ON/OFF switch to **ON** position (D). Power switch is illuminated when ON.

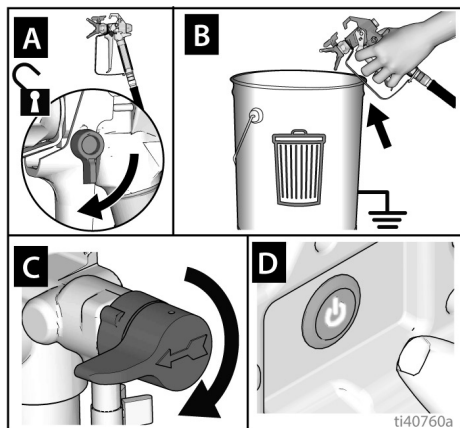

3. Trigger gun into waste pail until only paint comes out of the gun.

4. Release trigger. Engage trigger lock.

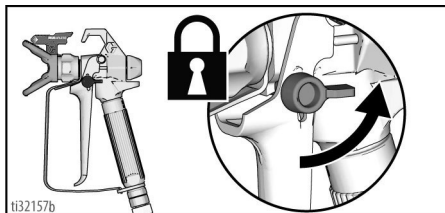

<p>High-pressure spray is able to inject toxins into the body and cause serious bodily injury. Do not stop leaks with hand or rag.</p>				

NOTE: Inspect for leaks. If leaking occurs, perform **Pressure Relief Procedure**, page 15, then tighten all fittings and repeat **Fill Pump (Prime Pump)**, page 17.

5. Transfer Drain Tube to paint pail and clip to Suction Tube.

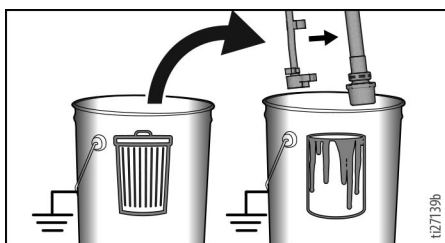

6. Rotate Spray Tip back to SPRAY position and ensure the Spray Tip Guard is tight.

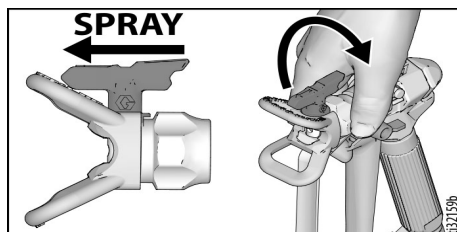

Refill Paint Pail

When the paint pail runs low and the gun stops spraying, refill the paint pail and repeat the **Fill Pump (Prime Pump)** procedure, then the **Fill Gun and Hose** procedure.

You are now ready to spray!

NOTE: It is normal for the motor to stop once the sprayer is primed and under pressure. If the motor continues to run, the sprayer is not primed. Repeat the **Fill Pump (Prime Pump)** and **Fill Gun and Hose** processes.

Blockages

If paint does not come out of the gun, or if you have performed the pressure relief procedure and you suspect pressure has not been fully relieved:

1. VERY SLOWLY loosen the hose connection to the gun and disconnect the airless spray hose from the gun.
2. Turn Prime/Spray Valve horizontal to SPRAY position.
3. While holding hose firmly, point end of hose into paint pail and turn ON/OFF switch to **ON** position. Button is illuminated when ON.
 - a. If fluid does not flow out of hose, replace the hose and continue to step 4.
 - b. If fluid flows out of hose, see **Clean the Gun and Gun Filter**, page 29.
4. Reassemble the hose and gun, and repeat **Fill Gun and Hose**, page 18.

Spraying



Start

1. Turn pressure control knob to **START** position. When spraying oil-based or flammable materials, follow **Grounding Instructions**, page 11.

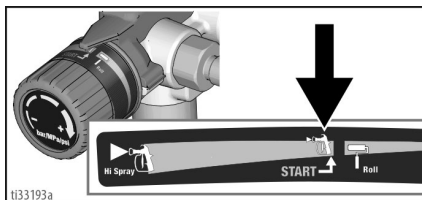

2. Disengage trigger lock.

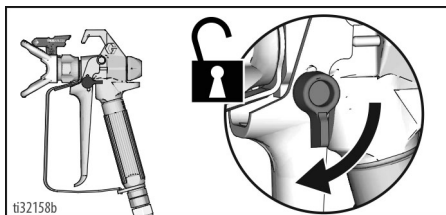

Adjust Pressure Control

To select a setting, align symbol on pressure control knob with setting indicator on sprayer.

1. For best spray results with lowest overspray, adjust pressure control to **"START"** setting.
2. Test the spray pattern on a test area or piece of cardboard.
3. If needed, increase Pressure Control Knob setting to minimum setting that results in an acceptable spray pattern.

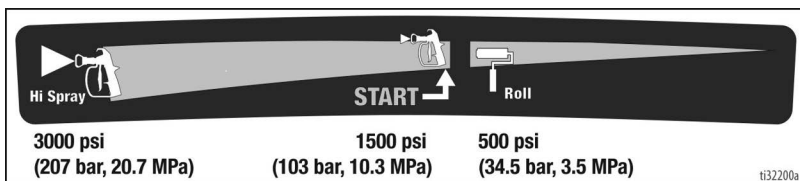

Spray Pattern Quality

A good spray pattern is evenly distributed as it hits the surface.

- Spray should be atomized (evenly distributed, no gaps at edges).
- Increase Pressure Control Knob setting if needed until spray is even and without gaps at edges.
- Spray Tip may be worn or a smaller tip may be needed. See **Spray Tip and Pressure Selection**, page 22.
- Material may need to be thinned. If material needs to be thinned follow manufacturer's recommendations.

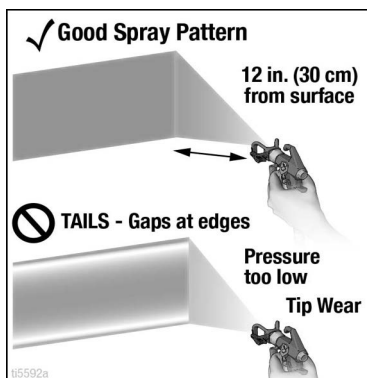

Spray Techniques

Use a piece of scrap cardboard to practice these basic spraying techniques before you begin spraying the surface.

- Hold gun 12 in. (30 cm) from surface and aim straight at surface. Tilting gun to direct spray angle causes an uneven finish.
- Flex wrist to keep gun pointed straight. Fanning gun to direct spray at angle causes uneven finish.

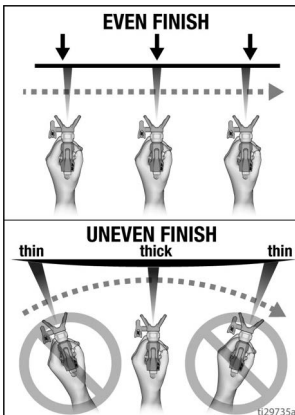
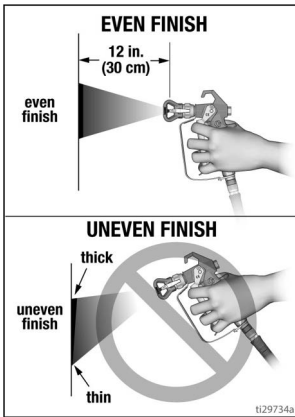

Trigger the Gun

Pull trigger after starting stroke. Release trigger before end of stroke. Gun must be moving when trigger is pulled and released.

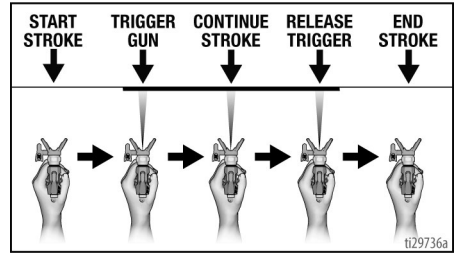

Aim Gun

Aim center of spray of gun at bottom edge of previous stroke, overlapping each stroke by half.

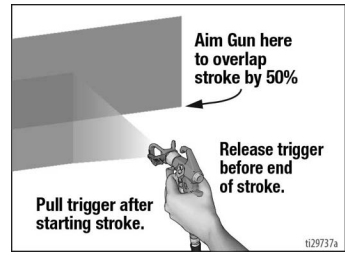

Align Spray Pattern

<p>High-pressure spray is able to inject toxins into the body and cause serious bodily injury. Do not stop leaks with hand or rag.</p>				

1. Relieve pressure. Perform **Pressure Relief Procedure**, page 15. Engage trigger lock.
2. Align guard horizontally to spray a horizontal pattern.
3. Align guard vertically to spray a vertical pattern.

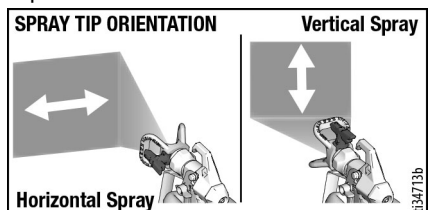

Spray Tip and Pressure Selection

Spray Tips come in a variety of sizes for spraying a wide range of materials. Your sprayer includes a 515 Spray Tip for use with most paints on large surfaces such as walls and ceilings. If you are spraying stain or need a different spray fan width, refer to the Spray Tip chart below to select the best Spray Tip for your project. Additional Spray Tip sizes are available where paint sprayers are sold.

Tip Number Calculation:

- The first digit is half of the fan width (#5 x 2 = 10 inch fan width).
- The last two digits are the size of the tip opening in thousandths of an inch.



- 1 What material are you spraying?
 - The thicker the material, the larger Spray Tip size you will need.
- 2 What spray fan width is needed for your project?
 - Narrow spray fan for smaller projects
 - Wider spray fan for larger projects

1 Material	2 Fan Width				
	4 in Fan Width	6 in Fan Width	8 in Fan Width	10 in Fan Width	12 in Fan Width
Stain and Sealer	209	309			
	211	311	411		
Semi Transparent Stain	211	311	411		
		313	413		
Solid Stain	211	311	411		
		313	413		
Interior Paint/Primer		315	415	515	
			417	517	
Exterior Paint/Primer			415	515	
			417	517	
				519	619
				521	621

- As you spray, the Spray Tip wears and as a result, the hole size gets larger. Starting with a Spray Tip hole size smaller than the maximum will allow you to spray longer within the compatibility of the sprayer.
- Spray Tips wear with use and need periodic replacement.

Clear Spray Tip Clog

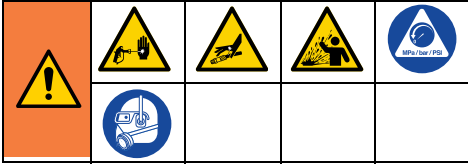

In the event that particles or debris clog the Spray Tip, the Spray Tip can be reversed to quickly and easily clear particles without disassembling the sprayer.

See **Strain the Paint**, page 17 for additional information.

1. Engage trigger lock. Rotate Spray Tip to UNCLOG position. Ensure spray tip remains fully seated, pushed all the way into the Spray Tip Guard. Disengage trigger lock. Trigger gun at waste area to clear clog.

UNCLOG

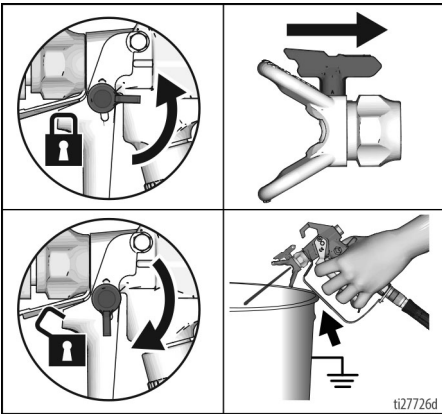

NOTE: If Spray Tip is difficult to rotate when turning to the UNCLOG position perform, **Pressure Relief Procedure**, page 15, then turn Prime/Spray Valve horizontal to SPRAY position and repeat step 1.

2. Engage trigger lock. Rotate Spray Tip back to SPRAY position. Disengage trigger lock and continue spraying.

SPRAY

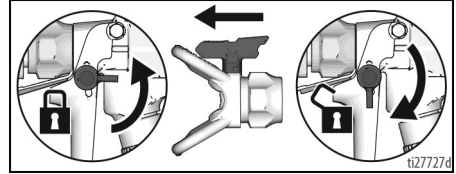

Spray Tip Installation



To prevent Spray Tip leaks make certain Spray Tip and Spray Tip Guard are installed properly.

1. Perform **Pressure Relief Procedure**, page 15.
2. Engage trigger lock.
3. Verify Spray Tip Guard parts are assembled in the order shown.

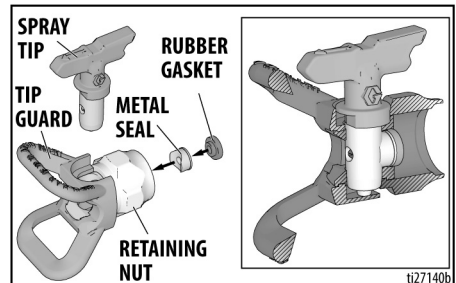

Spraying

- a. Use Spray Tip to align gasket and seal in the Spray Tip Guard.

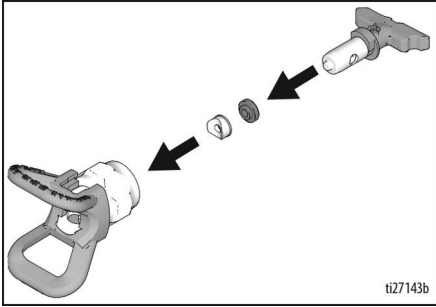

- b. Spray Tip must be pushed all the way into the Spray Tip Guard. Rotate Spray Tip while pushing down.

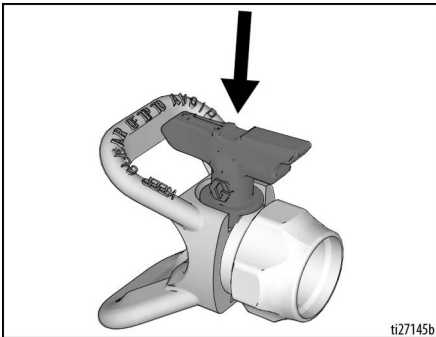

- c. Turn the arrow shaped handle on the Spray Tip forward to the SPRAY position.
4. Screw Spray Tip Guard assembly onto the gun and tighten.

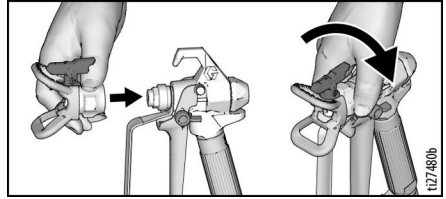

Cleanup

Cleaning the sprayer after each use helps ensure a more trouble-free start-up the next time the sprayer is used.

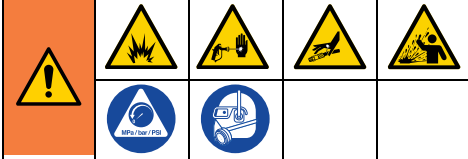

To avoid serious injury from fire and explosion when using oil-based or flammable materials:

- Do not spray solvents through the spray tip. Always remove tip guard and spray tip before flushing. Clean tip guard and spray tip in a bucket of compatible solvent.
- Clean in a well-ventilated area. Keep a good supply of fresh air moving through the area.
- When flushing with solvents, always ground the sprayer and waste container.

- For short term shutdown periods (overnight to two days), refer to **Short Term Storage**, page 30.
- For cleanup after using water-based materials only (by use of a garden hose), refer to **Cleanup with Power Flush Valve**, page 27.
- For cleanup from pails, refer to **Clean from a Pail**, below.
- For cleanup after using oil-based or solvent-based flammable materials, follow **Grounding Instructions**, page 11, and see **Cleaning Fluid Compatibility**, page 32.

Clean from a Pail

1. Perform **Pressure Relief Procedure**, page 15.
2. Remove battery, see **Battery Installation and Removal**, page 14.

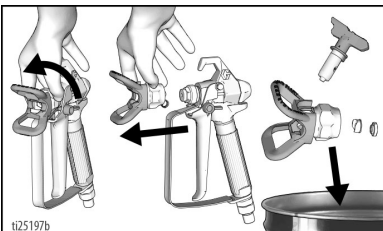

3. Remove Spray Tip Guard assembly from gun and place in waste pail.
4. Lift Suction Tube and Drain Tube from paint pail. Let paint drain into the pail.
5. Separate Drain Tube (smaller) from Suction Tube (larger).

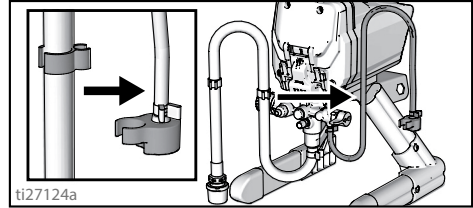

6. Place empty waste and flushing fluid pails side by side.
7. Place Suction Tube in flushing fluid. For water-based paints, use water. For non-water-based paints, use mineral spirits, paint thinner, or compatible flushing fluid. Place Drain Tube in waste pail.

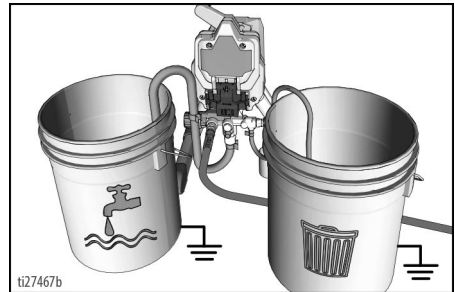

8. Turn Pressure Control Knob to the **START** position.

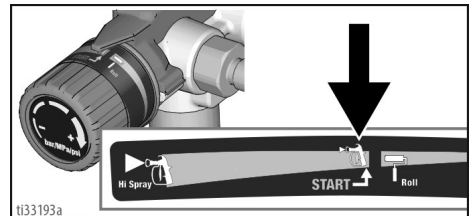

Cleanup

- Turn Prime/Spray valve down to PRIME position.

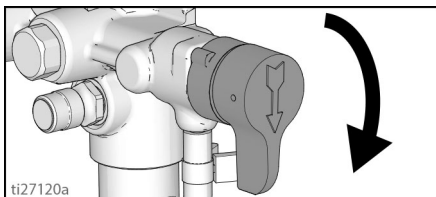

- Install battery, see **Battery Installation and Removal**, page 14.
- Turn ON/OFF switch to **ON** position. Button is illuminated when ON.
- Flush until approximately 1/3 of the flushing fluid is emptied from the pail.
- Turn ON/OFF switch to **OFF** position. Button is not illuminated when OFF.

NOTE: Step 14 is for returning paint in hose to paint pail. One 50 ft (15.2 m) hose holds approximately 1 quart (1 liter) of paint.

- To recover paint in hose, point gun into paint pail while holding gun firmly to the pail.
 - Disengage trigger lock (A).
 - Pull and hold gun trigger (B).
 - Turn Prime/Spray Valve horizontal to SPRAY position (C).
 - Turn ON/OFF switch to **ON** position (D). Button is illuminated

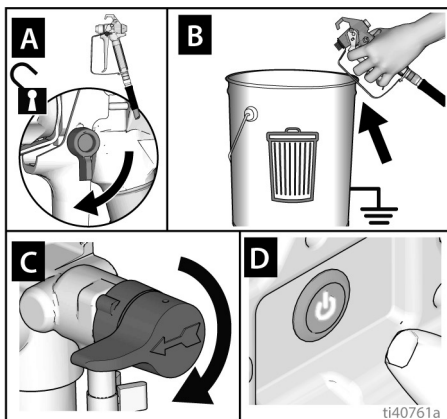

when ON.

- Continue to hold gun trigger until you see paint diluted with flushing fluid starting to come out of gun.

- While continuing to trigger gun, quickly move gun to redirect spray into waste pail. Continue triggering gun into waste pail until flushing fluid dispensed from gun is relatively clear.

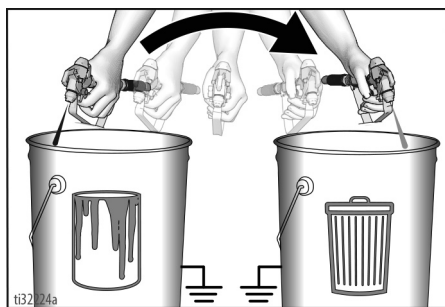

- Turn pressure control knob to the lowest setting.
- Stop triggering gun. Engage the trigger lock.

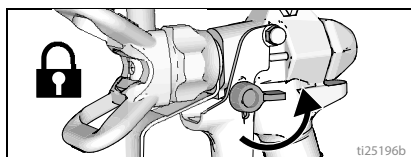

- Turn Prime/Spray Valve down to PRIME position.
- Turn ON/OFF switch to **OFF** position. Button is not illuminated when OFF.
- Remove battery, see **Battery Installation and Removal**, page 14.
- Follow **Short Term Storage** or **Long Term Storage**, page 30.

Cleanup with Power Flush Valve

(Water-based materials only)

Power flushing is a faster method of cleanup. It can only be used after spraying water-based coatings.

1. Perform **Pressure Relief Procedure**, page 15.
2. Engage trigger lock. Remove Spray Tip Guard assembly from gun and place in waste pail.

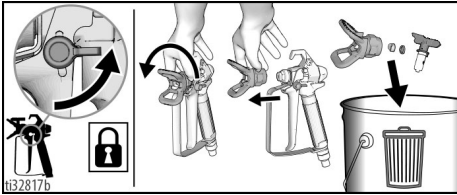

3. Place empty waste and paint pails side by side.
4. Lift Suction Tube and Drain Tube from paint pail. Let paint drain into the pail.
5. Place suction and Drain Tube in waste pail.

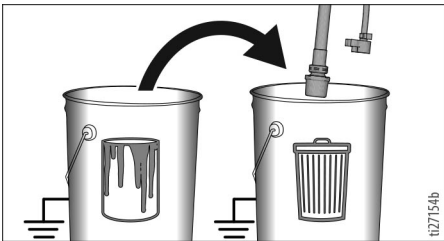

6. Turn pressure control knob to the **START** position.

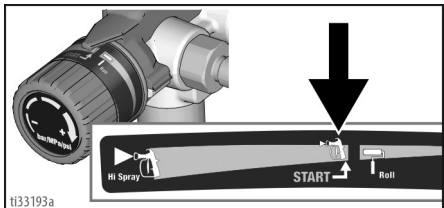

7. Screw Power Flush Valve (included with sprayer) to garden hose. Close Power Flush Valve.
8. Turn on water. Open Power Flush Valve. Rinse paint off Suction Tube, Drain Tube and inlet screen. Close Power Flush Valve.

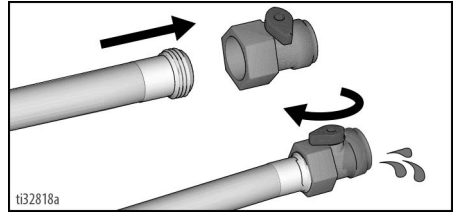

9. Unscrew inlet screen from Suction Tube. Place inlet screen in waste pail. Connect garden hose to Power Flush Valve on Suction Tube. Leave Drain Tube in waste pail.

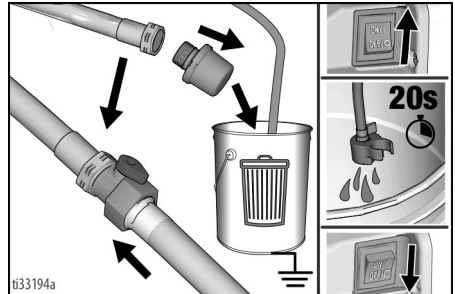

10. Install battery, see **Battery Installation and Removal**, page 14.
11. Turn ON/OFF switch to **ON** position. Button is illuminated when ON.
12. Open Power Flush Valve.
13. Circulate water through sprayer, into waste pail, for 20 seconds.
14. Turn ON/OFF switch to **OFF** position. Button is not illuminated when OFF.

NOTE: Step 15 is for returning paint in hose to paint pail. One 50 ft (15.2 m) hose holds approximately 1 quart (1 liter) of paint.

Cleanup

15. To recover paint in hose, point gun into paint pail while holding gun firmly to the pail.

- Disengage trigger lock (A).
- Pull and hold gun trigger (B).
- Turn Prime/Spray Valve horizontal to SPRAY position (C).
- Turn ON/OFF switch to **ON** position (D). Button is illuminated when ON.
- Continue to hold gun trigger until you see paint diluted with flushing fluid starting to come out of gun.

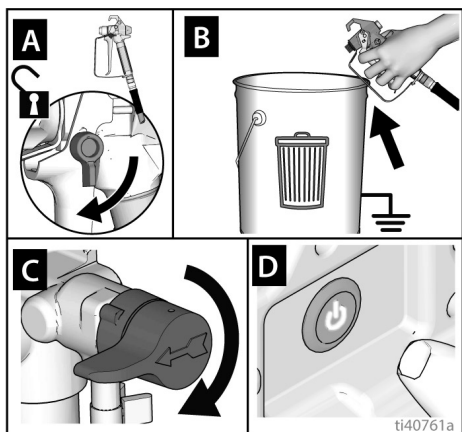

16. While continuing to trigger gun, quickly move gun to redirect spray into waste pail. Continue triggering gun into waste pail until flushing fluid dispensed from gun is relatively clear.

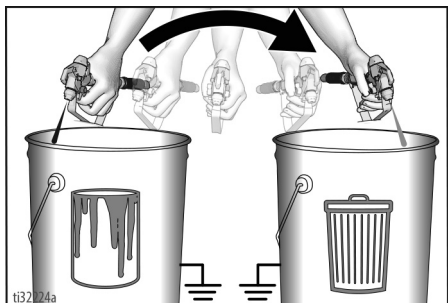

17. Turn pressure control knob to the lowest setting.

18. Stop triggering gun. Engage the trigger lock.

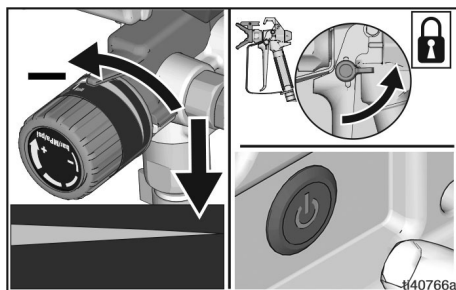

19. Turn Prime/Spray Valve down to PRIME position.

20. Turn ON/OFF switch to **OFF** position. Button is not illuminated when OFF.

21. Remove battery, see **Battery Installation and Removal**, page 14.

22. Follow **Short Term Storage** or **Long Term Storage**, page 30.

Clean InstaClean Filter

The InstaClean Filter prevents debris from entering paint hose. After each use, remove and clean it to ensure peak performance.

1. Perform **Pressure Relief Procedure**, page 15.
2. Disconnect airless spray hose (A) from sprayer.
3. Unscrew fluid outlet (B).
4. Remove InstaClean filter (C).

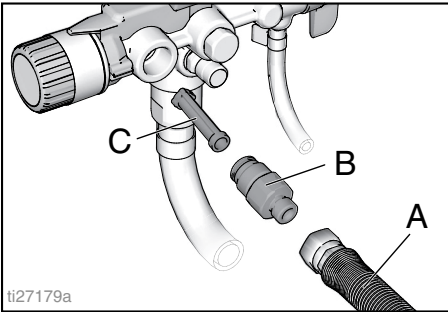

5. Check InstaClean Filter (C) for debris. If needed, clean filter with water or flushing fluid and a soft brush.
 - a. Install closed (square) end of InstaClean Filter (C) in sprayer.
 - b. Screw fluid outlet (B) into sprayer.
6. Tighten outlet valve and reconnect hose (A) to sprayer. Use two wrenches to tighten securely.

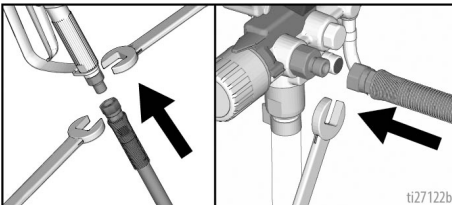

Clean the Gun and Gun Filter

1. Perform **Pressure Relief Procedure**, page 15.
2. Remove the gun handle by unscrewing the handle from the gun head.

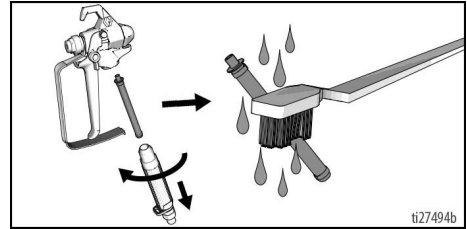

3. Clean gun filter with water or flushing fluid and a brush every time you flush the system. Replace gun filter if damaged.
4. Remove Spray Tip Guard assembly and clean with water or flushing fluid and a brush.

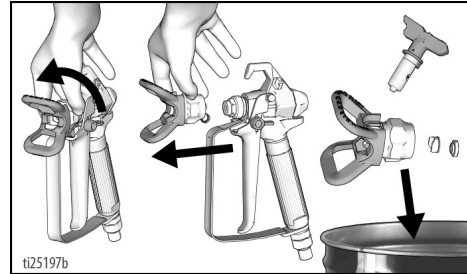

5. See **Spray Tip Installation**, page 23 to properly reinstall Spray Tip Guard assembly.
6. Wipe paint off outside of gun using a soft cloth moistened with water or flushing fluid.

Storage

Storage

With proper storage, the sprayer will be ready to use the next time it is needed.

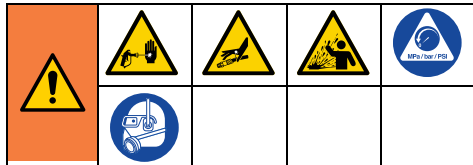

Short Term Storage

(up to 2 days)

1. Remove battery, see **Battery Installation and Removal**, page 14.
2. Leave Suction Tube and Drain Tube in paint pail.

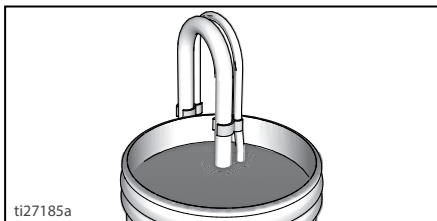

3. Cover paint and pail tightly with plastic wrap.

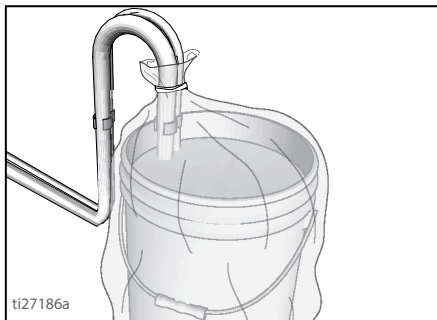

4. Engage trigger lock.

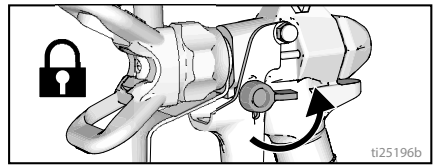

5. Leave gun attached to hose.
6. Remove Spray Tip and Spray Tip Guard and clean with water or flushing fluid and a brush.
7. Wipe paint off outside of gun using a soft cloth moistened with water or flushing fluid.

Long Term Storage

(more than 2 days)

Pump Armor™ fluid protects the sprayer against freezing and corrosion.

- Do not store the sprayer full of water.
- Do not allow water to freeze in sprayer.
- Do not store sprayer under pressure.
- Store sprayer indoors.

1. Perform **Cleanup**, page 25.
2. Remove Pump Armor bottle cap and foil seal.

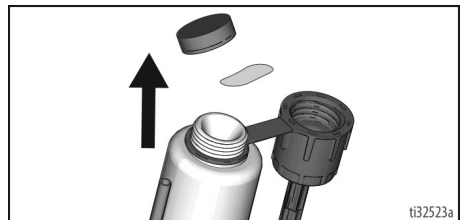

- If needed, unscrew Inlet Screen from Suction Tube. Turn Prime/Spray Valve down to **PRIME** position.

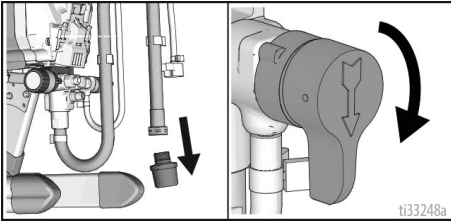

- Place drain tube in waste pail. Turn pressure control to the **START** position.

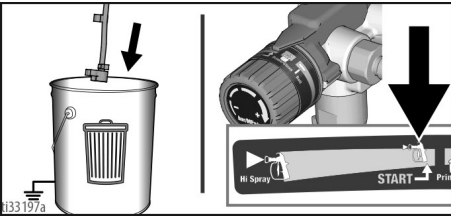

- Install battery, see **Battery Installation and Removal**, page 14.

- While holding the Suction Tube above the sprayer, pour approximately 2 ounces (1/4 cup) of Pump Armor into Suction Tube and turn Power Switch **ON**. Button is illuminated when ON.

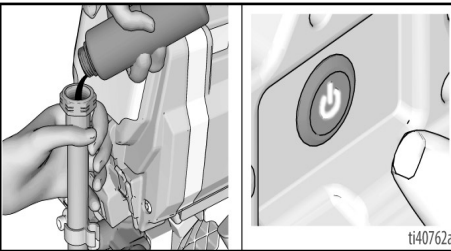

- When Pump Armor is flushed through the sprayer and out the Drain Tube, turn Power Switch **OFF**. Replace and tighten child-proof cap for storage.

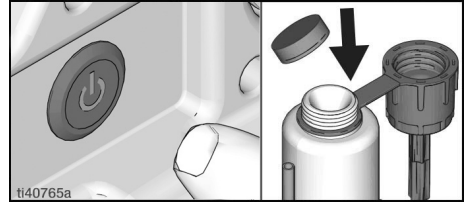

- Screw Inlet Screen back to Suction Tube. Ensure that spray gun and hose stay attached to sprayer.

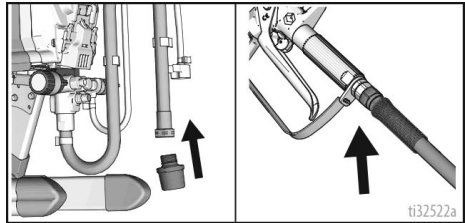

- Turn Spray/Prime Valve horizontal to **SPRAY** position for storage.

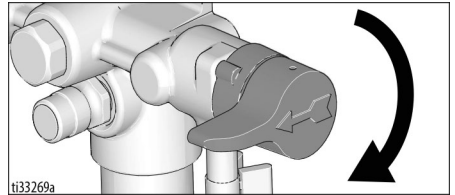

- Turn ON/OFF switch to **OFF** position. Button is not illuminated when OFF. Remove battery, see **Battery Installation and Removal**, page 14.

- Secure a plastic bag around Suction Tube and Drain Tube to catch any drips.

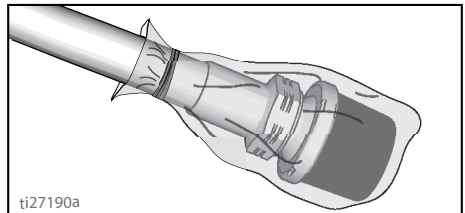

Reference

Lacquer Conversion Kit

To spray flammable materials, you must purchase a lacquer conversion kit. Contact customer service for lacquer conversion kit part number.

Follow **Grounding Instructions**, page 11, when spraying oil-based or flammable materials.

NOTICE

Spraying flammable materials without installing the lacquer conversion kit will damage your sprayer.

Cleaning Fluid Compatibility

- When spraying **water-based** materials, flush the system thoroughly with water.
- When spraying oil-based or flammable materials, flush the system thoroughly with mineral spirits or compatible flushing solvent. When flushing with solvents, always follow **Grounding Instructions**, page 11.
- To spray **water-based** materials **after spraying oil-based or flammable** materials and flushing with mineral spirits or compatible solvents, flush the system thoroughly with water first. The water flowing out of drain tube should be clear and solvent-free **before** you begin spraying the water-based material.
- To spray **oil-based or flammable** materials **after spraying water-based** materials and flushing with water, flush the system thoroughly with mineral spirits or a compatible flushing solvent first. The solvent flowing out of the drain tube should not contain any water. When flushing with solvents always follow **Grounding Instructions**, page 11.
- To avoid fluid splashing back on your skin or into your eyes, always aim gun at inside wall of pail.

Quick Reference

Page 10	Name	Description
A	Power - ON/OFF Switch	Turns sprayer ON and OFF.
B	Pressure Control Knob	Increases (clockwise) and decreases (counter-clockwise) fluid pressure in pump, hose, and spray gun. To select function, align symbol on pressure control knob with setting indicator.
C	Prime/Spray Valve	<ul style="list-style-type: none"> • In PRIME position directs fluid to Drain Tube. • In SPRAY position directs pressurized fluid to paint hose. • Automatically relieves system pressure in overpressure situations.
D	Spray Tip	<ul style="list-style-type: none"> • Atomizes fluid being sprayed, forms spray pattern and controls fluid flow according to hole size. • Reverse position unclogs plugged Spray Tips without disassembly.
E	PushPrime Button	Taps the inlet ball when pushed to loosen it.
F	Suction Tube	Draws fluid from paint pail into pump.
G	Drain Tube (with diffuser)	Drains fluid in system during priming and pressure relief.
H	Airless Spray Gun	Dispenses fluid.
J	Spray Tip Guard	Reduces risk of fluid injection injury.
K	Gun Trigger Lock	Prevents accidental triggering of spray gun.
L	Gun Fitting	Threaded connection for Airless Hose.
M	Gun Filter (inside handle)	Filters fluid entering spray gun to reduce Spray Tip clogs.
N	ProXChange™ Pump	Pumps and pressurizes fluid and delivers it to Airless Hose.
O	Inlet Valve	Allows paint to flow from paint bucket into the sprayer.
P	Airless Hose Connection	Threaded connection for airless hose.
Q	Airless Hose	Transports high-pressure fluid from pump to spray gun.
R	InstaClean Filter	<ul style="list-style-type: none"> • Filters fluid coming out of pump to reduce Spray Tip clogs and improve finish. • Self cleans only during pressure relief.
S	Pail Hanger	For transporting pail by its handle.
T	Inlet Screen	Prevents debris from entering pump.
U	Battery	Power source for sprayer.
V	Easy Access Door	Permits quick access to the pump. Open pump door by pulling out on the tabs while sliding door up.
X	Pump Removal Tool	Cut out in the frame provides the tools to quickly remove the pump packing without additional tools.
Y	Outlet Valve	Allows paint to flow from the sprayer to the gun.
Z	Inlet Valve Removal Tool	Cut out in the frame provides the tools to quickly remove the inlet valve without additional tools.
	Power Flush Valve	Connects garden hose to Suction Tube for power flushing water-based fluids.
AA	Battery Cover	Protects the battery.
AB	Ground Wire w/ Clamp	Provides means to maintain good ground continuity.
AC	Outlet Ground Adapter	Provides a means to attach grounding wire clamp to grounded electrical outlet.

Maintenance

Routine maintenance is important to ensure proper operation of your sprayer.



Maintenance Activity

1. Inspect motor shroud openings for blockage every time you spray.
2. Clean/inspect inlet screen, InstaClean filter, and gun filter every time you spray. Replace if the filter cannot be cleaned or is damaged.

NOTICE

Protect the internal drive parts of this sprayer from water. Openings in shroud allow cooling of mechanical parts and electronics inside. If water gets into these openings, the sprayer could malfunction or be permanently damaged.

Airless Hoses

Check hose for damage every time you spray. Do not attempt to repair hose if hose jacket or fittings are damaged. Do not use hoses shorter than 25 ft. (7.6 m). Wrench tighten, using two wrenches.

Spray Tips

- Always clean Spray Tips with compatible cleaning fluid and brush after spraying.
- Tips may require replacement after 15 gallons (57 liters) or they may last through 60 gallons (227 liters) depending on abrasiveness of paint. See **Spray Pattern Quality**, page 20.

Storage/Priming Tool

Perform these steps if you are experiencing difficulty priming your sprayer.

1. Perform **Pressure Relief Procedure**, page 15.
2. Remove Pump Armor bottle cap. Insert small fluid tube into bottom of Storage/Prime Tool, and thread tool onto the bottle. **NOTE:** For best results, make sure the bottle is full of Pump Armor.

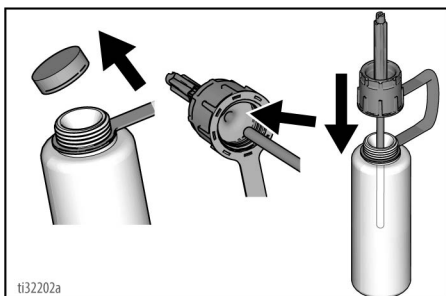

3. Remove sprayer Suction Tube. Insert tool into the inlet and push up firmly until it stops.

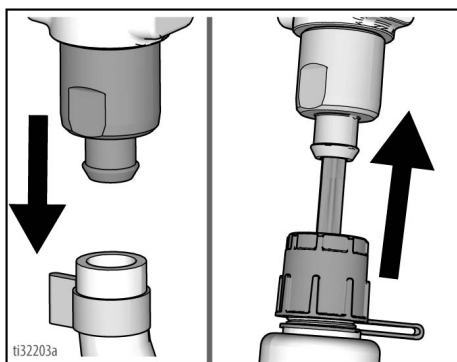

4. Squeeze Pump Armor bottle until Pump Armor flows into the Drain Tube.

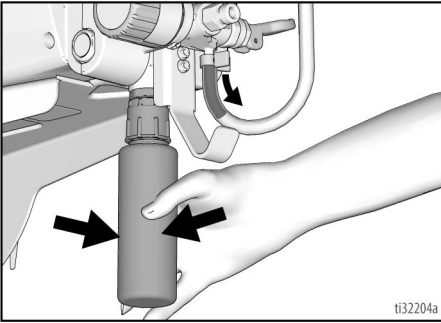

5. Remove tool. Replace and tighten child-proof cap for storage.

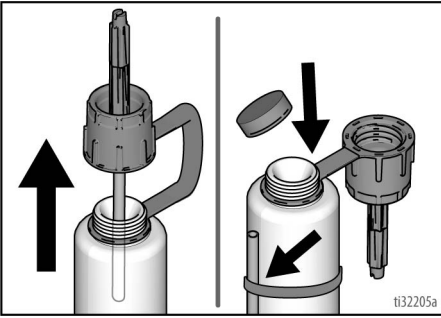

6. Reinstall the sprayer Suction Tube. Ensure that the tube is snug on the inlet and the clamp is engaged.

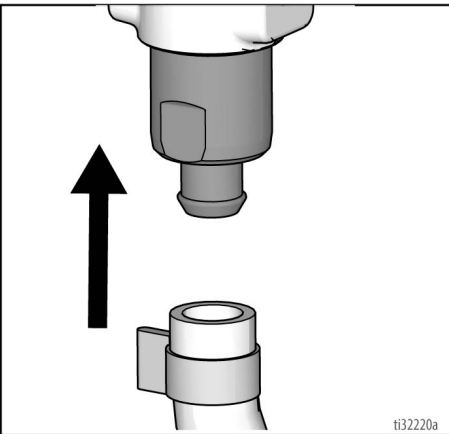

Inlet Valve Removal

An integrated tool is included in the frame to remove the inlet valve assembly from the pump. If you suspect that the inlet valve is clogged or stuck, remove the valve assembly and clean or replace.

1. Perform **Pressure Relief Procedure**, page 15.
2. Insert pump inlet into frame and loosen the inlet valve. Remove inlet valve.

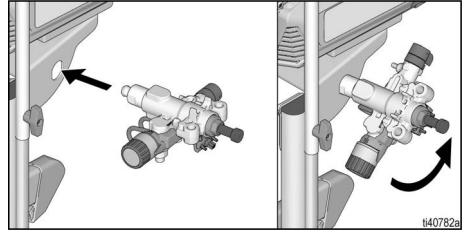

3. Remove inlet valve. Clean and reinstall.

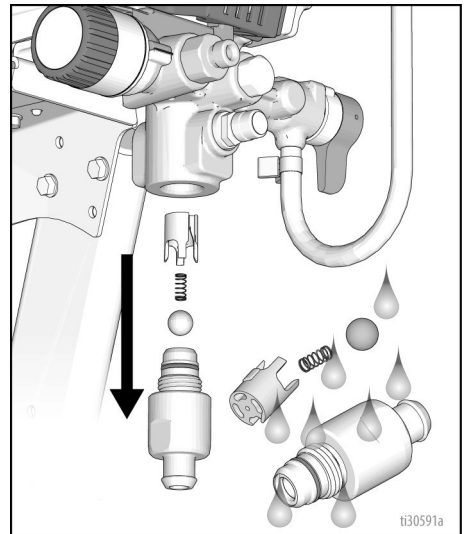

NOTICE

Do not lose the ball and spring inside the inlet valve assembly. It may fall out when the inlet valve is removed. Pump will not prime without the ball and spring.



Maintenance

4. Perform a power flush. See **Cleanup with Power Flush Valve**, page 27 and **Cleaning Fluid Compatibility**, page 32

				
High-pressure spray is able to inject toxins into the body and cause serious bodily injury. Do not stop leaks with hand or rag.				

5. Inspect for leaks. If leaks occur, perform **Pressure Relief Procedure**, page 15, then tighten all fittings and repeat step 3.

Pump Repair



When pump packings wear, paint will begin to leak down outside of pump. Purchase a pump repair kit and install according to instructions provided with kit, before your next job. See **ProXChange Pump Parts List**, page 46, or consult a Graco/MAGNUM authorized retailer, distributor, or service center.

Each time the pump kit is replaced, check pump inlet and outlet valves for wear or damage. Replace if worn or damaged. Always replace inlet and outlet valves every second time the pump kit is replaced.

Pump Removal

Remove airless hose, suction tube, and drain tube. Always perform **Pressure Relief Procedure**, page 15 before starting any pump repairs.

1. Perform Pressure relief procedure, see **Pressure Relief Procedure**, page 15.
1. Remove battery, see **Battery Installation and Removal**, page 14.

2. Pull tabs on sides of the easy access door towards you while pushing the entire door up.
3. Now lift the door so that it swings out of the way.

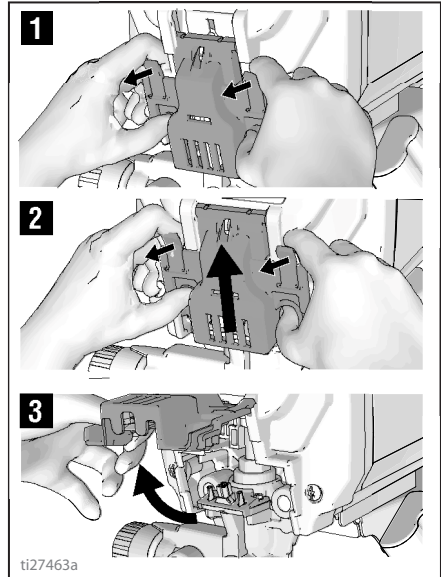

4. Slide pump assembly off the mounting pins.

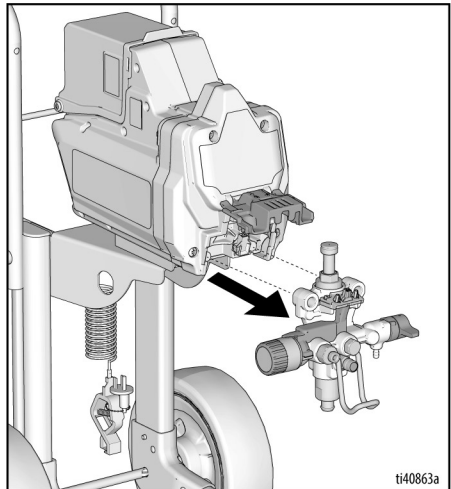

ProXChange Removal Tool

An integrated tool is included in the frame to remove the ProXChange packing assembly. See ProXChange Pump manual for complete repair instructions.

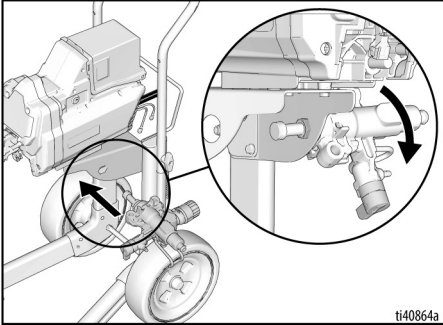

ti40864a

Pump Installation

1. Slide pump assembly onto the mounting pins.

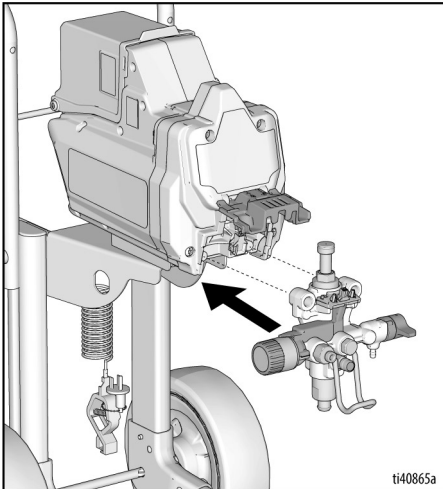

ti40865a

- a. Move pump rod up or down until cap is level with the opening in the yoke.

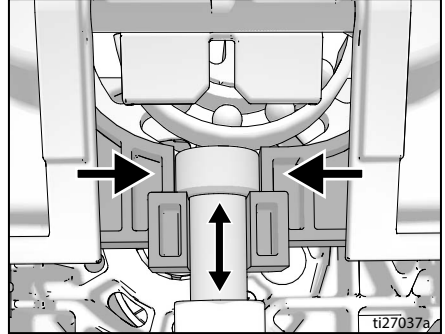

ti27037a

- b. Push on pump rod to slide pump assembly back on to mounting pins.
2. Swing Easy Access Door closed while pushing the entire door down.

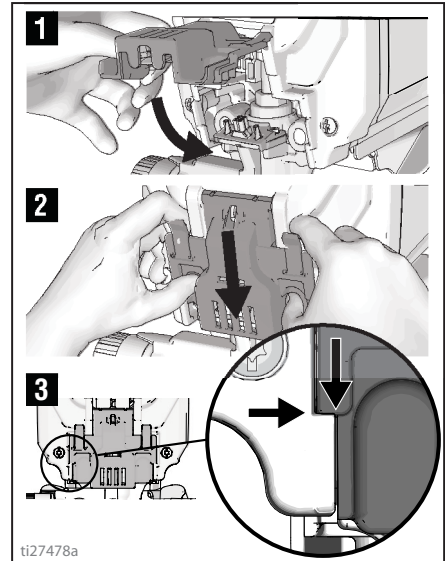

ti27478a

3. Install hose, suction tube, and drain tube.
4. Install battery, see **Battery Installation and Removal**, page 14.

NOTE: Door must be fully closed and latched before sprayer will operate.

Troubleshooting

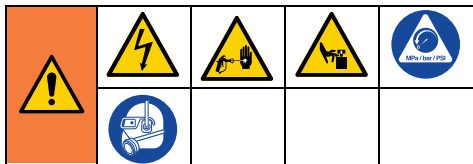

3. Check everything in this Troubleshooting Table before you bring the sprayer to an authorized service center.

1. Follow **Pressure Relief Procedure**, page 15, before checking or repairing.
2. Solutions at the beginning of each problem listed are the most common.

Have a Question?
Call Us Toll-Free: 1-888-541-9788
 or visit us at:
www.magnum.graco.com

024021a

Problem	Cause	Solution
Motor does not run: (verify battery is installed and charged, and ON/OFF switch is on)	Easy Access Door not fully closed	Verify that Easy Access Door is closed and latched. See step 2 of Pump Installation , page 37.
	Pressure control is set at zero pressure.	Turn pressure control knob clockwise to increase pressure setting.
	Battery has insufficient charge.	Charge battery.
	Battery is defective.	Replace battery.
	Pump is seized (Paint has hardened in pump or water is frozen in pump.)	Turn ON/OFF switch off and remove battery. If frozen do NOT try to start sprayer until it is completely thawed or it may damage the motor, control board and/or drive train. Place sprayer in warm area for several hours. Check for free moving pump by removing shroud and spinning fan. If not frozen, check for hardened paint in pump. If paint has hardened in pump. See Pump Repair , page 36. If motor does not turn with pump removed, consult a Graco/ Magnum authorized retailer, distributor, or service center.
Motor or control is damaged.	Consult a Graco/ Magnum authorized retailer, distributor, or service center.	

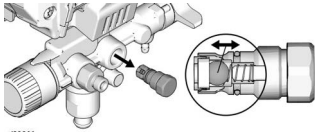
Problem	Cause	Solution
Sprayer runs, but pump does not prime or loses prime while in use. (Pump cycles but does not pull paint into Suction Tube or build pressure.)	Prime/Spray Valve is in SPRAY position.	Turn Prime/Spray Valve down to PRIME position until paint exits Drain Tube.
	Inlet screen is clogged or Suction Tube is not completely immersed in paint.	Clean debris off inlet screen and make sure Suction Tube is completely immersed in paint.
	Inlet or outlet valve ball is stuck or dirty.	Press PushPrime button twice to loosen inlet valve and reprime sprayer. See Fill Pump (Prime Pump) , page 17. See Storage/Priming Tool , page 34. Then reprime pump. Remove inlet and/or outlet valves and clean, replace and reprime. See Fill Pump (Prime Pump) , page 17. <ul style="list-style-type: none"> • Make certain to not lose the ball and spring of the inlet valve assembly or the sprayer will not function. See Inlet Valve Removal, page 35. • Make certain the outlet ball moves free in the housing before replacing. 
	Suction Tube is leaking.	Inspect Suction Tube connection for cracks or vacuum leaks.
	Debris in paint causing obstruction.	Strain the paint. See Strain the Paint , page 17.
Prime/Spray Valve is worn or obstructed with debris.	Take sprayer to Graco/MAGNUM authorized service center.	

Troubleshooting

Problem	Cause	Solution
Pump is primed, but can not achieve good spray pattern.	Spray Tip may be partially clogged.	See Clear Spray Tip Clog , page 23.
	Reversible Spray Tip is in UNCLOG position.	Rotate arrow-shaped handle on Spray Tip so it points forward to SPRAY position. See page 23.
	Debris in paint causing obstruction.	Strain the paint. See Clear Spray Tip Clog , page 23.
	Pressure is set too low.	Align pressure control knob setting indicator to desired spray setting. See Clear Spray Tip Clog , page 23.
	InstaClean Filter is clogged.	Clean or replace InstaClean filter. See Clean InstaClean Filter , page 29.
	Spray gun filter is clogged.	Clean or replace gun filter. See Clear Spray Tip Clog , page 23.
	Spray Tip selected is too large for capability of sprayer.	Replace Spray Tip. See Spray Techniques , page 21.
	Spray Tip is worn beyond the capability of sprayer.	Replace Spray Tip. See Spray Techniques , page 21.
	Spray Tip gasket and seal worn or missing.	Replace gasket and seal. See Spray Techniques , page 21.
	Inlet screen is clogged or Suction Tube is not immersed in paint.	Clean debris off inlet screen and make sure Suction Tube is immersed in paint.
	Battery has insufficient charge for tip support.	Charge battery or reduce tip size.
	Inlet valve or outlet valve is worn or clogged with debris.	<p>Check for worn or contaminated inlet valve or outlet valve.</p> <ul style="list-style-type: none"> - Prime sprayer with paint - Trigger gun momentarily - When trigger is released, pump should cycle momentarily and stop - If pump continues to cycle, pump valves may be worn or contaminated with debris - See Storage/Priming Tool, page 34. - Clean and reinstall valves. - Replace valves with appropriate kits. For kit part numbers, see ProXChange Pump Parts List, page 46.
	Material is too thick.	Thin material. Follow manufacturers recommendations.
Airless hose is too long (if extra section was added).	Remove section of airless hose.	
Spray gun stopped spraying while trigger is pulled.	Spray Tip is clogged.	See Clear Spray Tip Clog , page 23
	Sprayer lost prime.	Reprime sprayer. See Fill Pump (Prime Pump) , page 17.
		See Troubleshooting , page 38.

Problem	Cause	Solution
When paint is sprayed, it runs down the wall or sags.	Material is going on too thick.	Move gun faster.
		Choose a Spray Tip with smaller hole size.
		Choose Spray Tip with wider fan.
		Make sure gun is far enough from surface.
When paint is sprayed, coverage is inadequate.	Material is going on too thin.	Move gun slower.
		Choose Spray Tip with larger hole size.
		Choose Spray Tip with narrower fan.
		Make sure gun is close enough to surface.
Fan pattern varies dramatically while spraying.	Pressure control switch is worn and causing excessive pressure variation.	Take sprayer to Graco/MAGNUM authorized service center.
Cannot trigger spray gun.	Spray gun trigger lock is engaged.	Rotate trigger lock to disengage trigger lock.
Paint is coming out of pressure control switch.	Pressure control switch is worn.	Take sprayer to Graco/MAGNUM authorized service center.
Paint is leaking through Drain Tube.	Sprayer is over pressurizing.	Take sprayer to Graco/MAGNUM authorized service center.
Paint leaks down outside of pump.	Pump packings are worn.	Replace pump. See .
Motor is hot and runs intermittently. Motor automatically shuts off due to excessive heat. Damage can occur if cause is not corrected.	Vent holes in enclosure are plugged or sprayer is covered.	Keep vent holes clear of obstructions and overspray and keep sprayer open to air.
	Battery has insufficient charge.	Charge battery.
	Motor needs to be replaced.	Take sprayer to Graco/Magnum authorized retailer, distributor, or service center.
Sprayer makes no sound when pressure control is ON and ON/OFF switch is ON (illuminated).	ON/OFF switch light blinks two times when pressure control is ON. Indicates incorrect voltage.	Replace battery with charged battery.
		Battery has reached end of life. Replace battery.
		Motor damaged, replace motor assembly.
	ON/OFF switch light blinks three times when pressure control is ON. Indicates battery temperature is too hot or too cold.	Allow battery to cool down or warm up to room temperature.
	ON/OFF switch light blinks four times when pressure control is ON. Indicates locked rotor condition.	Replace pump and/or motor assembly.
ON/OFF switch light blinks five times when pressure control is ON. Indicates motor temperature is too hot.	Allow motor to cool down to room temperature.	

Troubleshooting

Problem	Cause	Solution
ON/OFF switch does not illuminate when pressed.	Indicates battery is not installed, has insufficient charge, or is damaged.	Install battery correctly, ensure battery is fully charged, or replace battery.
	Control board is damaged.	Replace control board.
	Power switch is damaged.	Replace power switch.
ON/OFF switch is constantly illuminated (does not turn off).	Control board is damaged.	Replace control board.

Online Resources

Visit Our Website:	magnum.graco.com
Operational Videos:	magnum.graco.com/magop/
Manuals:	magnum.graco.com/support/#manuals
Parts Online:	magnum.graco.com/partsonline/

ProX19 Cordless Cart Sprayer Parts

ProX19 Cordless Cart Sprayer Parts

Ref.	Torque	Ref.	Torque
	110-120 in-lb (12-14 N•m)		23-27 in-lb (2.6-3.0 N•m)
	30-35 in-lb (3.5-4.0 N•m)		80-90 in-lb (9-10.2 N•m)
	8-10 in-lb (0.9-1.2 N•m)		180-220 in-lb (20.3-24.0 N•m)
	45-55 in-lb (5-6 N•m)		55-65 in-lb (6.2-7.3 N•m)

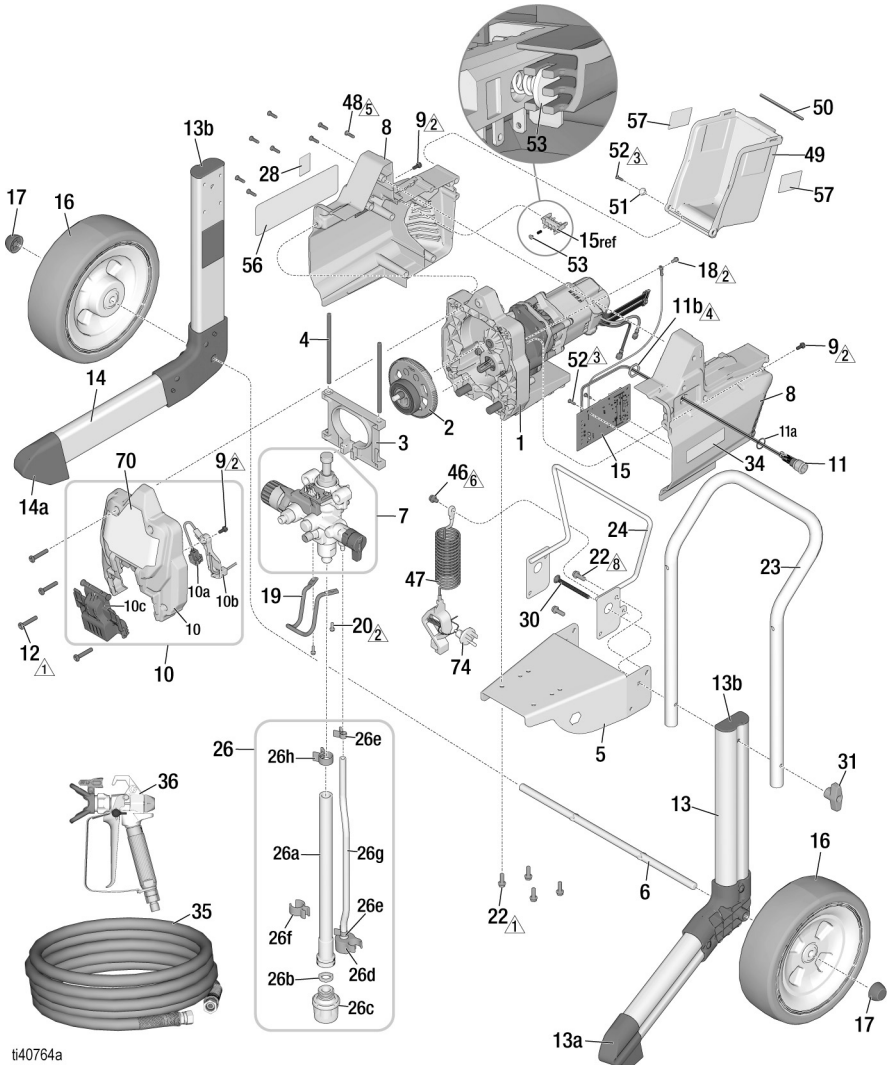





ProX19 Cordless Cart Sprayer Parts

ProX19 Cordless Cart Sprayer Parts List

Ref.	Part	Description	Qty.	Ref.	Part	Description	Qty.
1	20A066	KIT, motor, <i>includes 22</i>	1	26f	195400	CLIP, spring	1
2	17J863	KIT, gear and yoke	1	26h	116295	CLAMP, tube	1
4	17J864	KIT, yoke	1	26g	195108	TUBE, drain	1
5	17G541	PLATE, motor, mount	1	27	17J819	PLUG, hole, 1 in.	1
6	16W362	AXLE, cart	1	28	16D576	LABEL, made in USA	1
7	17J874	KIT, pump complete	1	30	120788	SCREW, carriage	2
8	20A979	SHIELD, motor, blue <i>includes 9, 48, and labels</i>	1	31	115480	KNOB, T-handle	2
9	118444	SCREW, mach, hwhd 10-24 x 0.5 in.	3	34	17K516	LABEL, A+	1
10	17J866	COVER, front <i>includes 9, 10a, 10b, 10c, 12</i>	1	35	247340	HOSE, cpld, 1/4 in. x 50 ft	1
10a	128551	CABLE, jumper, PC	1	36	243012	GUN, spray, SG3	1
10b	17F262	COVER, wire	1	37	115648	VALVE, power flush (not shown)	1
10c	17F233	COVER, pump, locking	1	38	17S980	FLUID, pump armor, 8 oz (not shown)	1
11	19D610	SWITCH, ON/OFF	1	46	112798	SCREW, thd forming, hex hd	1
11a		O-RING, power switch	1	47	237686	WIRE, ground assy with clamp	1
11b		NUT, power switch	1	48	115477	SCREW, mach, torx, pan hd.	8
12	115478	SCREW, mach, Torx, pan hd	1	49	20A980	KIT, cover, battery, <i>includes 50, 51, 52, 57</i>	1
13	17K186	LEG, left, <i>includes 13a, 13b</i>	1	50	19D421	GASKET, door, battery shield	1
13a	16W517	CAP, tube, left	1	51	20A010	BUTTON, door, hinge	1
13b	15J699	CAP, tube	2	52	119236	SCREW, mach, torx, pan hd.	3
14	17K185	LEG, right, <i>includes 14a, 13b</i>	1	53	25V553	KIT, spring and pin, <i>includes 53a</i>	1
14a	16W505	CAP, tube, right	2	53a		SPRING, button assy	1
15	20A542	KIT, control board 120V <i>includes 52</i>	1	56 ▲	20A915	LABEL, warning	1
16	17K546	WHEEL <i>includes 17</i>	2	57	20A309	LABEL, brand, Dewalt	2
17	112612	CAP, hub	2	60		GUIDE, Magnum quick guide, 60V US	1
18	115498	SCREW, mach, slot, hex whd	1		20A981	CAN	1
19	17J430	HOOK, pail	1	64	17Y794	TAG, hang, tip (not shown)	1
20	117501	SCREW, plastite	3	65 ▲	15G026	TAG, warning, hose, (not shown)	1
22	260212	SCREW, hwh, thread forming	8	70	20A864	LABEL, front	1
23	16H353	HANDLE, cart	1	74	25U292	ADAPTER, ground plug	1
24	20A865	RACK, hose	1	75 ▲	179960	CARD, medical alert (not shown)	1
26	24V073	TUBE, suction, assembly <i>includes 26a, 26b, 26c, 26d, 26e, 26f, 26g, 26h</i>	1				
26a	16H348	TUBE, suction <i>includes 26b</i>	1				
26b	115099	WASHER, hose	1				
26c	288716	STRAINER, inlet	1				
26d	244035	DEFLECTOR, barbed	1				
26e	115489	CLAMP, drain tube	2				

▲ Replacement safety labels, tags, and cards are available at no cost.

ProXChange Pump Parts

Ref.	Torque
 1	140-160 in-lb (16-18 N•m)
 2	30-35 in-lb (3.4-4.0 N•m)
 3	30-35 ft-lb (40-48 N•m)
 4	220-250 in-lb (25-28 N•m)
 5	320-380 in-lb (36-43 N•m)

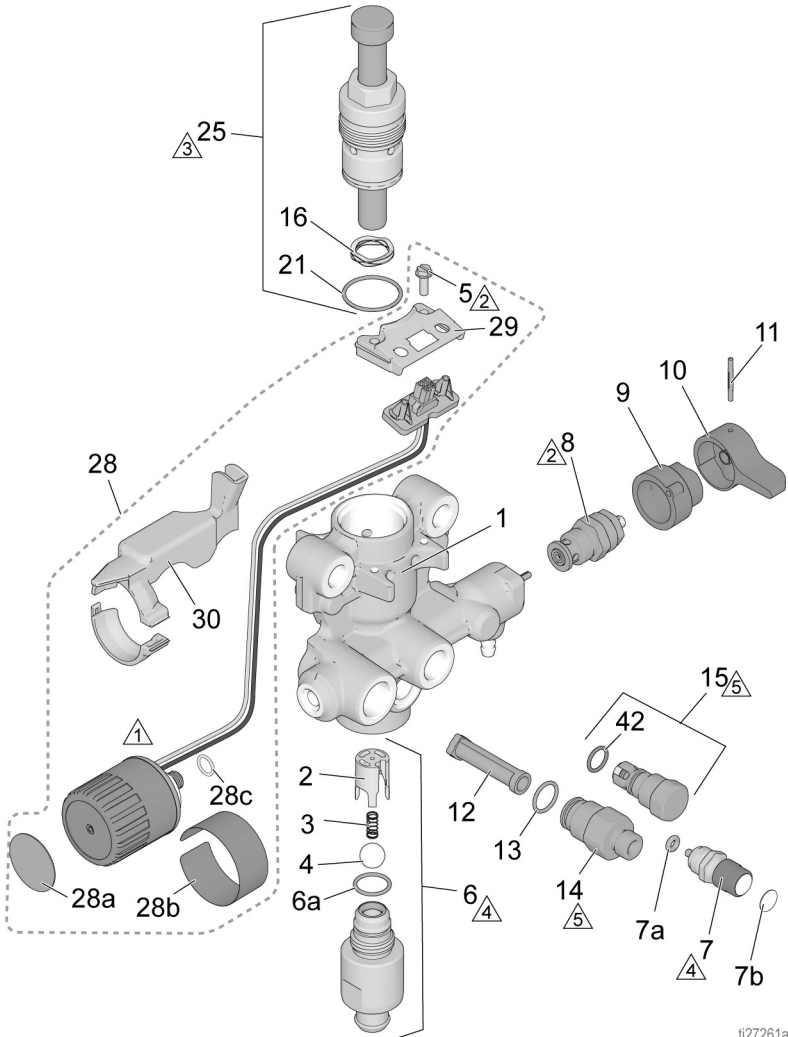

ti27261a

ProXChange Pump Parts

ProXChange Pump Parts List

Ref. Part	Description	Qty.	Ref. Part	Description	Qty.
1	17G447 HOUSING, pump	1	13	120776 PACKING, O-ring	1
2	17D364 GUIDE, ball	1	14	24Y327 KIT, repair outlet	1
3	128336 SPRING, compression	1		<i>includes 12,13</i>	
4	105445 BALL, 0.5 in.	1	15	17J880 KIT, outlet valve repair	1
5	117501 SCREW, mach, slot	2		<i>includes 42</i>	
	HWH		16	128323 SPRING, valve	1
6	KIT, inlet housing		21	16D531 PACKING, O-ring	1
	17J876 ProX17, ProX19	1	25	24Y472 KIT, repair, piston	1
	17J877 ProX21	1		pump	
6a	124582 O-ring	1	28	17J881 KIT, pressure control	1
7	17J878 KIT, PushPrime	1		<i>includes 5, 28a, 28b,</i>	
	<i>includes 7a, 7b</i>			<i>28c, 29, 30</i>	
7a	16P303 PACKING, O-ring	1	28a	15A464 LABEL, control	1
7b	17G540 LABEL, PushPrime	1	28b	17V191 LABEL, control	1
8	235014 VALVE, drain, assy	1	28c	106555 O-ring	1
9	224807 BASE, valve	1	29	17F227 BRACKET, electrical	1
10	187625 HANDLE, valve, drain	1		connector	
11	111600 PIN, grooved	1	30	17F229 KIT, shield, wire	1
12	288747 KIT, filter	1	42	122486 PACKING, O-ring	1

Wiring Diagram - 60VDC

Wiring Diagram - 60VDC

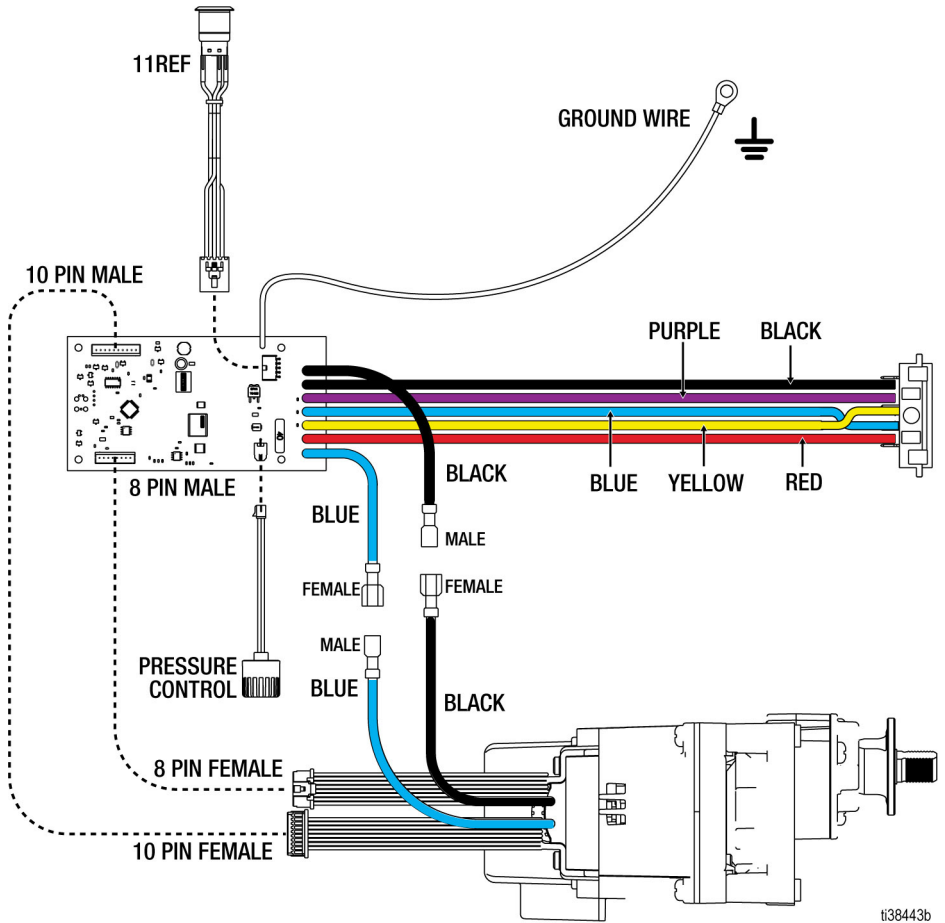

Technical Specifications

Technical Specifications

ProX19 Cordless	US	Metric
Sprayer		
Maximum fluid working pressure	3000 psi	207 bar, 20.7 MPa
Maximum Delivery	0.38 gpm	1.4 lpm
Maximum Spray Tip Size	0.019 in.	0.48 mm
Fluid Outlet npsm	1/4 in.	1/4 in.
Power Requirements	See page 2 for battery compatibility	
Dimensions		
Height	36.7 in.	93.0 cm
Length	20.2 in.	51.3 cm
Width	17.2 in.	43.7 cm
Weight	46.0 lb.	20.9 kg
Storage temperature range ♦♦	-30° to 160°F	-35° to 71°C
Operating temperature range ✓	40° to 115°F	4° to 46°C
Noise		
Sound Pressure	83 dBa**	
Sound Power	93 dBa**	
Materials of Construction		
Wetted materials on all models	stainless steel, brass, leather, ultra-high molecular weight polyethylene (UHMWPE), carbide, nylon, aluminum, PVC, polypropylene, fluoroelastomer, plated steel	
Notes		
* Startup pressures and displacement per cycle may vary based on suction condition, discharge head, air pressure, and fluid type.		
** Sound pressure measured 3 feet (1 meter) from equipment. Sound power measured per ISO-9614.		
All trademarks or registered trademarks are the property of their respective owners.		

♦ When pump is stored with non-freezing fluid, pump damage will occur if water or latex paint freezes in pump.

❖ Damage to plastic parts may result if impact occurs in low temperature conditions.

✓ Changes in paint viscosity at very low or very high temperatures can affect sprayer performance.

California Proposition 65

CALIFORNIA RESIDENTS

 **WARNING:** Cancer and reproductive harm –
www.P65warnings.ca.gov.

Graco Standard Warranty

Graco warrants all equipment referenced in this document which is manufactured by Graco and bearing its name to be free from defects in material and workmanship on the date of sale to the original purchaser for use. With the exception of any special, extended, or limited warranty published by Graco, Graco will, for a period of twelve months from the date of sale, repair or replace any part of the equipment determined by Graco to be defective. This warranty applies only when the equipment is installed, operated and maintained in accordance with Graco's written recommendations.

This warranty does not cover, and Graco shall not be liable for general wear and tear, or any malfunction, damage or wear caused by faulty installation, misapplication, abrasion, corrosion, inadequate or improper maintenance, negligence, accident, tampering, or substitution of non-Graco component parts. Nor shall Graco be liable for malfunction, damage or wear caused by the incompatibility of equipment with structures, accessories, equipment or materials not supplied by Graco, or the improper design, manufacture, installation, operation or maintenance of structures, accessories, equipment or materials not supplied by Graco.

This warranty is conditioned upon the prepaid return of the equipment claimed to be defective to an authorized Graco distributor for verification of the claimed defect. If the claimed defect is verified, Graco will repair or replace free of charge any defective parts. The equipment will be returned to the original purchaser transportation prepaid. If inspection of the equipment does not disclose any defect in material or workmanship, repairs will be made at a reasonable charge, which charges may include the costs of parts, labor, and transportation.

THIS WARRANTY IS EXCLUSIVE, AND IS IN LIEU OF ANY OTHER WARRANTIES, EXPRESS OR IMPLIED, INCLUDING BUT NOT LIMITED TO WARRANTY OF MERCHANTABILITY OR WARRANTY OF FITNESS FOR A PARTICULAR PURPOSE.

Graco's sole obligation and buyer's sole remedy for any breach of warranty shall be as set forth above. The buyer agrees that no other remedy (including, but not limited to, incidental or consequential damages for lost profits, lost sales, injury to person or property, or any other incidental or consequential loss) shall be available. Any action for breach of warranty must be brought within two (2) years of the date of sale.

GRACO MAKES NO WARRANTY, AND DISCLAIMS ALL IMPLIED WARRANTIES OF MERCHANTABILITY AND FITNESS FOR A PARTICULAR PURPOSE, IN CONNECTION WITH ACCESSORIES, EQUIPMENT, MATERIALS OR COMPONENTS SOLD BUT NOT MANUFACTURED BY GRACO. These items sold, but not manufactured by Graco (such as electric motors, switches, hose, etc.), are subject to the warranty, if any, of their manufacturer. Graco will provide purchaser with reasonable assistance in making any claim for breach of these warranties.

In no event will Graco be liable for indirect, incidental, special or consequential damages resulting from Graco supplying equipment hereunder, or the furnishing, performance, or use of any products or other goods sold hereto, whether due to a breach of contract, breach of warranty, the negligence of Graco, or otherwise.

FOR GRACO CANADA CUSTOMERS

The Parties acknowledge that they have required that the present document, as well as all documents, notices and legal proceedings entered into, given or instituted pursuant hereto or relating directly or indirectly hereto, be drawn up in English. Les parties reconnaissent avoir convenu que la rédaction du présente document sera en Anglais, ainsi que tous documents, avis et procédures judiciaires exécutés, donnés ou intentés, à la suite de ou en rapport, directement ou indirectement, avec les procédures concernées.

Graco Information

For the latest information about Graco products, visit www.graco.com.

For patent information, see www.graco.com/patents.

TO PLACE AN ORDER, contact your Graco distributor or call 1-800-690-2894 to identify the nearest distributor.

All written and visual data contained in this document reflects the latest product information available at the time of publication. Graco reserves the right to make changes at any time without notice.

Original instructions. This manual contains English. MM 3A9019

Graco Headquarters: Minneapolis

International Offices: Belgium, China, Japan, Korea

GRACO INC. AND SUBSIDIARIES • P.O. BOX 1441 • MINNEAPOLIS MN 55440-1441 • USA

Copyright 2021, Graco Inc. All Graco manufacturing locations are registered to ISO 9001.

www.graco.com

Revision C, January 2023