

LineDriver[®] ES Lithium

3A9034E

EN

For the propulsion of line striping and removal equipment. For professional use only. Not approved for use in explosive atmospheres or hazardous (classified) locations.

Models: 25U670, 25U671



10 mph (16 kph) Maximum Operating Speed



Important Safety Instructions

Read all warnings and instructions in this manual and in related LineLazer[®], GrindLazer[®] and ThermoLazer[®] manuals before using the equipment. Save these instructions.

Related Manuals:	
Power Sonic Quick Guide (Scan QR code below)	
710-0138	Delta-Q Battery Charger
3A6720	Hitch Receiver Kit

LineDriver ES Lithium			
	Model	Series	Cord Adapter
	25U670	B	North America
  	25U671	B	North America Australia CEE 7/7 Denmark Italy Switzerland United Kingdom

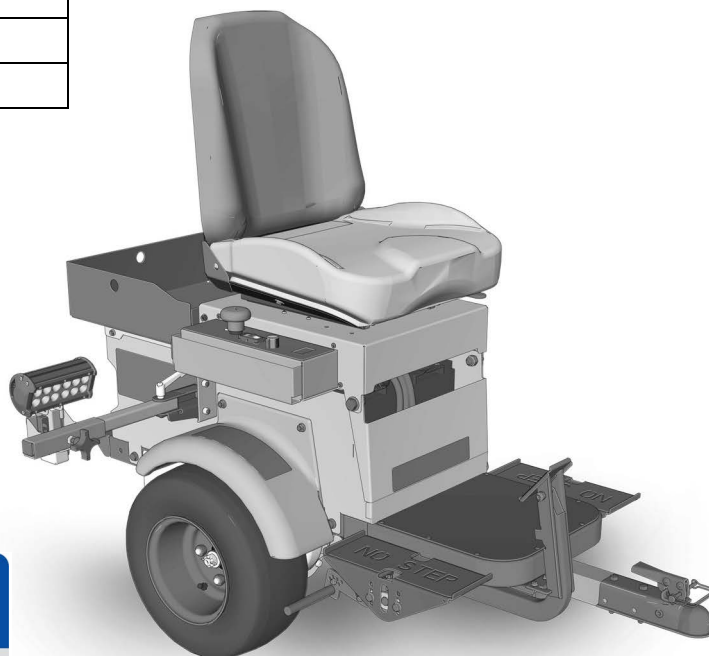

POWER SONIC
TRUSTED BATTERY SOLUTIONS

SMART BATTERY

 **LEARN MORE ABOUT THE LITHIUM BLUETOOTH BATTERY SERIES**

 Quick Guide

 App Download

Use only genuine Graco replacement parts.
The use of non-Graco replacement parts may void warranty.

SERVICE
to every customer, every time

 ??  ??
www.graco.com/techsupport













Contents

Warnings	3	Repair	19
Component Identification	6	Battery Pack Replacement	19
Setup	7	Transaxle Replacement	20
12V Auxiliary Ports	7	Traction Motor Replacement	20
Startup	8	Motor Controller Replacement	20
Know Your Controls	8	Motor Replacement: Series A to Series B	20
Daily Inspections	9	Recycling and Disposal	21
Operation	10	Rechargeable Battery Disposal	21
Differences in Operation	10	End of Product Life	21
How to Operate	10	Troubleshooting - LineDriver	22
Operating on Inclines	11	Troubleshooting - Motor Controller	23
Trailer Loading & Unloading	11	Parts Drawing	28
Charging the Batteries	12	Parts Drawing	29
Maintenance	14	Parts Drawing - Detail Views	30
Parking/Emergency Brake Adjustment or Replacement	14	Parts Drawing	31
Throttle Linkage Adjustment	15	Parts List	32
Coupler Adjustment	16	Wiring Diagram - Harness 25N661	34
Accelerator Calibration (Using Kit 25N880)	17	Wiring Diagram	35
Transaxle Service	18	Wiring Diagram - Harness 25E406	36
		Technical Specifications	37
		Graco Standard Warranty	39
		Graco Information	39

Warnings

The following warnings are for the setup, use, grounding, maintenance, and repair of this equipment. The exclamation point symbol alerts you to a general warning and the hazard symbols refer to procedure-specific risks. When these symbols appear in the body of this manual or on warning labels, refer back to these Warnings. Product-specific hazard symbols and warnings not covered in this section may appear throughout the body of this manual where applicable.

 <h1 style="margin: 0;">WARNING</h1>	
	<p>MOVING VEHICLE HAZARD</p> <p>Careless and reckless behavior causes accidents. Falling from vehicle, running into people or objects, or being struck by other vehicles may result in serious injury or death.</p> <ul style="list-style-type: none"> • Do not operate unless attached to line striping or line removal equipment. • Do not step on Direction/Speed Pedals. • Make turns slowly. Do not make turns greater than 45°. • Loss of traction may occur going downhill. • Do not operate on inclines greater than 7.5°. • Do not carry passengers. • Do not tow. • Use with line striping or line removal equipment only. • Use appropriate traffic control in all traffic areas. Refer to manual on Uniform Traffic Control Devices (MUTCD), U.S. Department of Transportation, Federal Highway Administration or local highway and transportation regulations.
 	<p>TRAFFIC HAZARD</p> <p>Vehicle strikes may result in serious injury or death.</p> <ul style="list-style-type: none"> • Do not operate in traffic. • Use traffic control.
 	<p>ELECTRIC SHOCK HAZARD</p> <p>This equipment must be grounded. Improper grounding, setup, or usage of the system can cause electric shock.</p> <ul style="list-style-type: none"> • Turn off and disconnect power cord before servicing equipment. • Connect only to grounded electrical outlets. • Use only 3-wire extension cords. • Ensure ground prongs are intact on power and extension cords. • Do not expose to rain. Store indoors.
	<p>EQUIPMENT MISUSE HAZARD</p> <p>Misuse can cause death or serious injury.</p> <ul style="list-style-type: none"> • Do not operate the unit when fatigued or under the influence of drugs or alcohol. • Check equipment daily. Repair or replace worn or damaged parts immediately with genuine manufacturer's replacement parts only. • Do not alter or modify equipment. Alterations or modifications may void agency approvals and create safety hazards. • Make sure all equipment is rated and approved for the environment in which you are using it. • Use equipment only for its intended purpose. Call your distributor for information. • Keep children and animals away from work area. • Comply with all applicable safety regulations.
	<p>BURN HAZARD</p> <p>Equipment surfaces and fluid that is heated can become very hot during operation. To avoid severe burns:</p> <ul style="list-style-type: none"> • Do not touch hot fluid or equipment.

WARNING



BATTERY HAZARD

The battery may leak, explode, cause burns, or cause an explosion if mishandled. Contents of an open battery can cause severe irritation and/or chemical burns. If on skin, wash with soap and water. If in eyes, flush with water for at least 15 minutes and get immediate medical attention.

- Replace battery only in a well-ventilated area and away from flammable or combustible materials, including paints and solvents.
- When battery is not in use, keep it away from metal objects like keys, nails, screws or other metal objects that can short circuit the battery terminals.
- Do not throw into fire.
- Charge only with Graco approved charger as listed in this manual.
- Do not store or charge at temperatures below 32° or above 113°F (0° to 45°C).
- Do not use at temperatures below 14° or above 140°F (-10° to 60°C).
- Do not expose battery to water or rain.
- Do not disassemble, crush, or penetrate the battery.
- Do not use or charge a battery that is cracked or damaged.
- Follow local ordinances and/or regulations for disposal.



CHARGER ELECTRIC SHOCK, FIRE AND EXPLOSION HAZARD

Improper setup or usage can cause electric shock, fire, and explosion.



- Charge only in a well-ventilated area and away from flammable or combustible materials, including paints and solvents.
- Do not charge on a combustible or flammable surface.
- Do not leave battery unattended while charging.
- Immediately unplug charger when charging is complete.
- Charge only Graco approved batteries listed in this manual; other batteries may burst.
- Use only in dry locations. Do not expose to water or rain.
- Do not use a charger that is cracked or damaged.
- If the supply cord is damaged, replace the charger or cord, depending on model.
- Disconnect the charger from the outlet before cleaning.
- Ensure that the outside surface of the battery is clean and dry before plugging into the charger.
- Do not attempt to charge non-rechargeable batteries.
- Do not disassemble the charger. Take charger to authorized service center when service or repair is required.

Component Identification

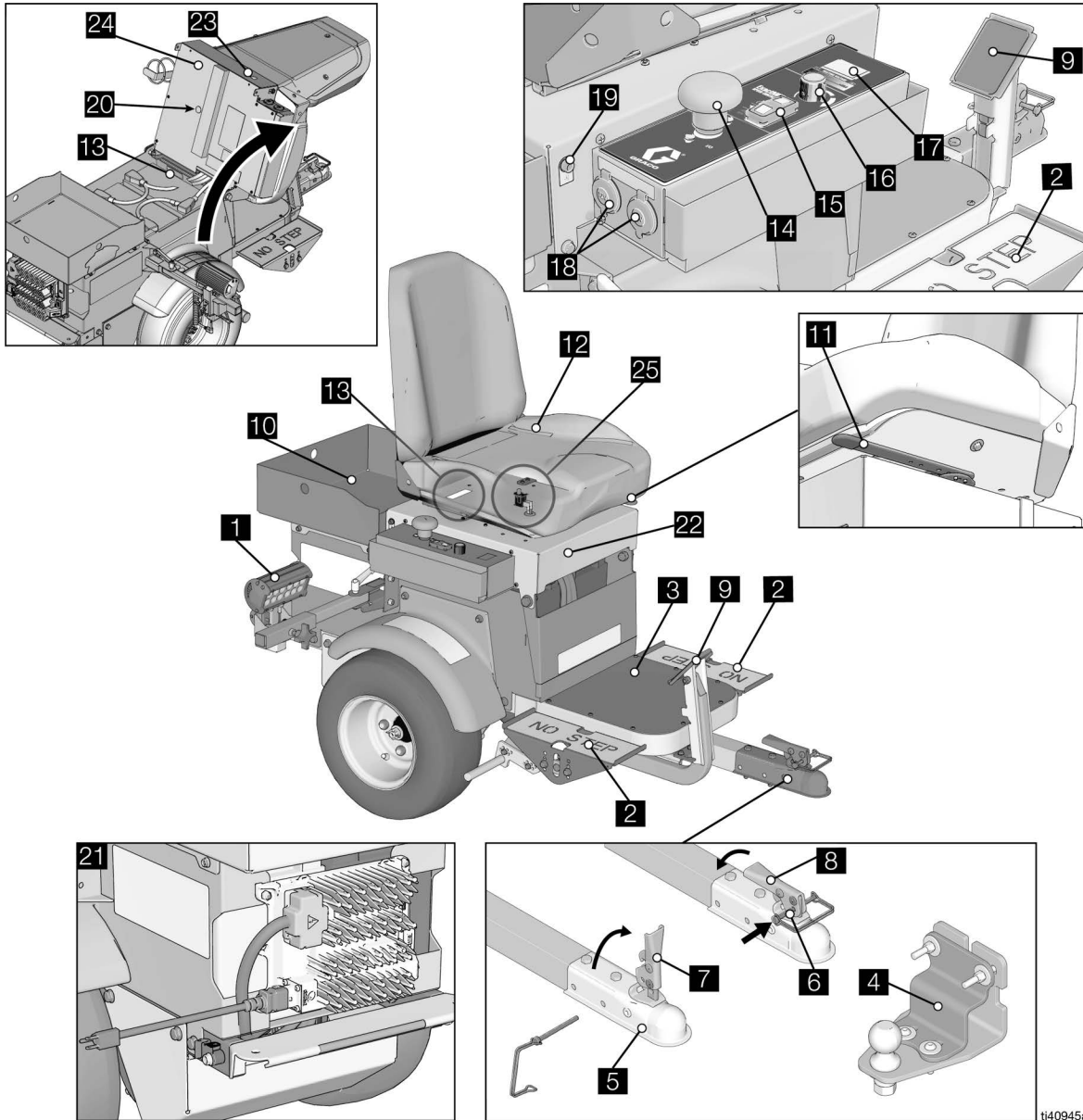

1	Headlight
2	Direction/Speed Pedals
3	Step Plate
4	Hitch
5	Coupler
6	Safety Pin Location
7	Handle Open
8	Handle Locked
9	Parking/Emergency Brake
10	Tool Tray
11	Seat Adjustment
12	Operator Seat
13	Serial ID

14	Power Switch
15	Speed Switch
16	ExactMil™ Speed Control
17	Voltage Meter
18	12V Aux. Power
19	Light Socket
20	Motor Controller Diagnostic Light
21	Battery Charger
22	Seat Lid
23	Buzzer
24	Seat Cover
25	Seat Interlock Switch

Setup

1. Install supplied ramp onto pallet.
2. Connect Hitch Receiver to line stripping or line removal equipment - **Hitch Receiver Kit 25N787; Manual 3A6720.**

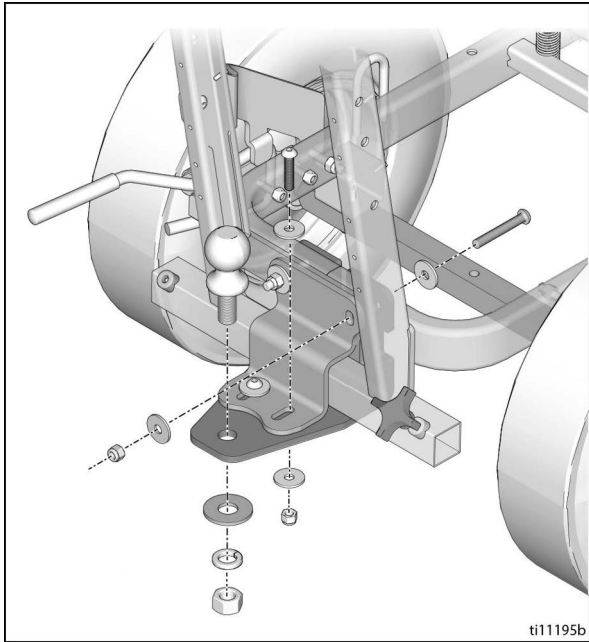

3. Install LineDriver Coupler to striper or grinder hitch ball.

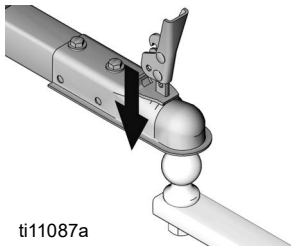

4. Latch Coupler to locked position (M).

NOTE: If Coupler is too tight to latch or is loose after latching, Coupler needs adjustment. Refer to **Coupler Adjustment**, page 16.

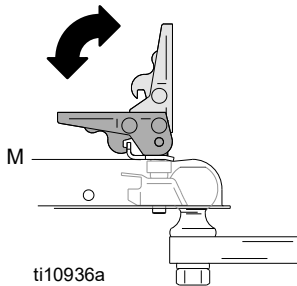

5. Insert safety pin in latch

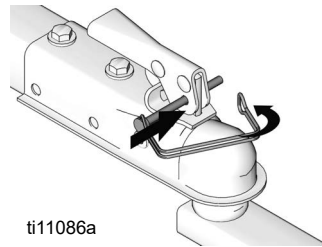

6. Adjust seat forward/backward with lever below seat.

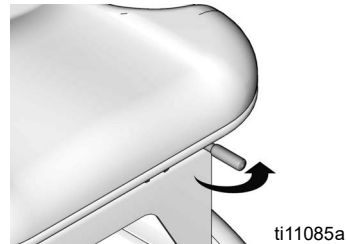

7. Adjust height of pedals to desired position by removing/replacing bolts (Y).
8. Loosen two bolts (C) on topside of pedals. Rotate pedal to desired position. Tighten bolts.

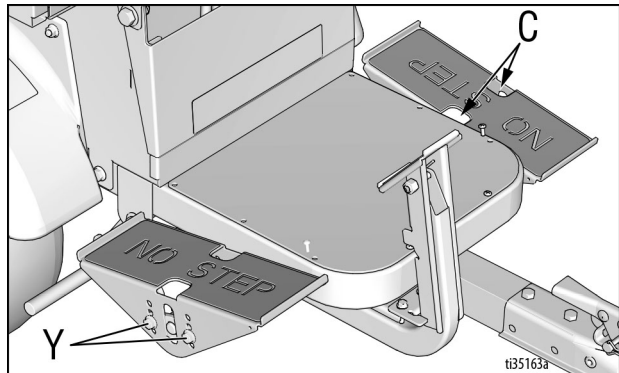

12V Auxiliary Ports

12V auxiliary power ports are provided to power accessories.

NOTICE

12V auxiliary ports must be used to power accessories. Battery damage can result if other means are used to power accessories.

Startup

Know Your Controls

Direction/Speed Pedals

The Direction/Speed Pedals drive the LineDriver forward and in reverse. Switching from forward to reverse creates a braking action. When both feet are removed from the pedals, the LineDriver stops. Use one or both feet to operate the pedals.

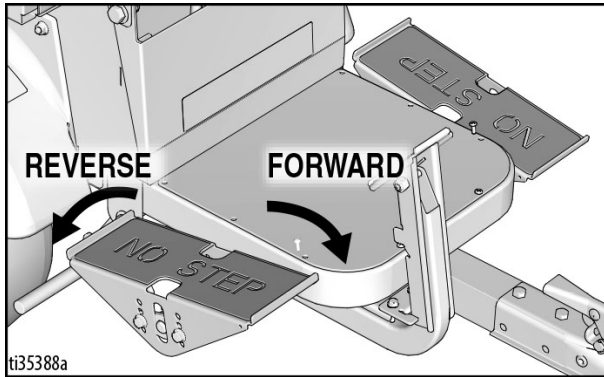

Parking/Emergency Brake

The Parking/Emergency Brake stops the machine in an emergency and prevents it from rolling when parked. To engage the Parking/Emergency Brake, press brake pedal firmly until it latches. To release, press the lower edge of the brake pedal.

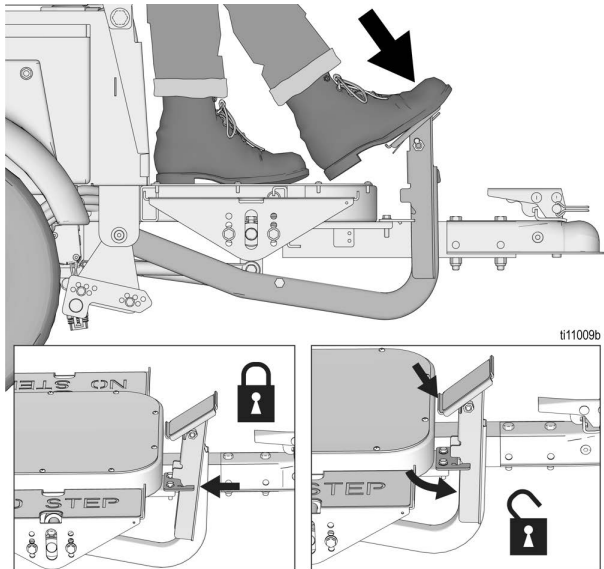

Speed Switch

ExactMil™ (Speed Control) Mode

ExactMil Mode ensures a consistent paint thickness by holding the speed steady. To enable ExactMil mode:

1. Stop moving. Turn speed control knob all the way counterclockwise.
2. Set Speed Switch to ExactMil  position.

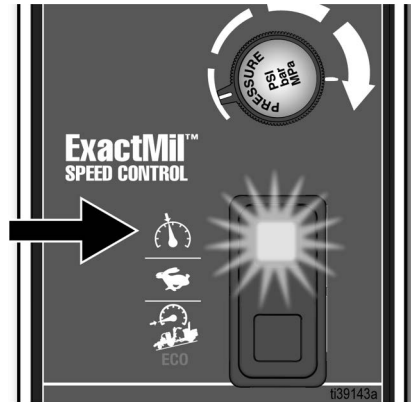

3. Depress foot pedal to go forward. Adjust speed control knob to desired speed setting.

NOTE: ExactMil speed control is only active when moving forward. Reverse speed is not impacted. ExactMil speed control limits the maximum speed that can be obtained with the pedal.

To disable ExactMil Mode:

- Return Speed Switch to center position.

Full Speed Mode

Set Speed Switch to the center  position. This allows a forward speed of 10 mph (16 kph) and a reverse speed of 7 mph (11 kph).

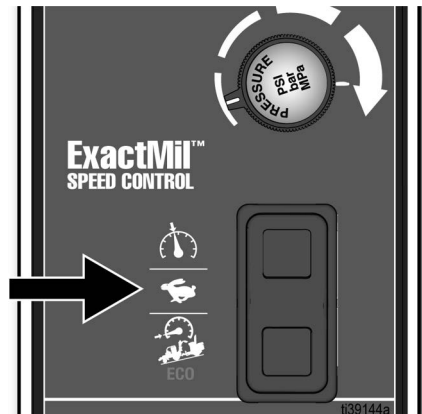

Incline/ECO Mode

Incline/ECO Mode is the recommended default mode for all operations. It is helpful when greater control is needed such as during loading or unloading and in congested areas. Incline/ECO mode should be used when operating on inclines. It also extends battery life. To enable Incline/ECO mode:

- Set Speed Switch to Incline/ECO  position.

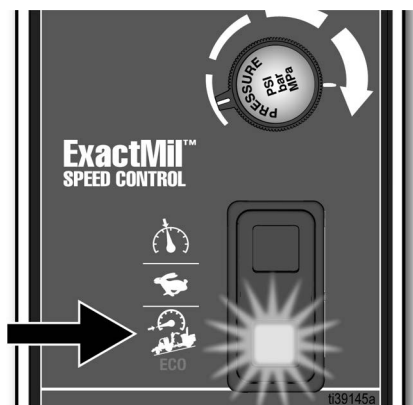

NOTE: Incline/ECO Mode limits forward speed to 5.5 mph (9 kph) and reverse speed to 4 mph (6 kph).

To disable Incline/ECO Mode:

- Return Speed Switch to center position.

Buzzer

A buzzer will sound to indicate different operating conditions.

Single tone, about one second long, after turning the Power Switch ON.	Direction/Speed control pedals now active.
Repeating tone, about every second.	Batteries are deeply discharged. See Charging the Batteries , page 12.
Continuous tone while traveling faster than 6.5 mph (10 kph).	Reduced braking available from Direction/Speed Pedals. See warning in Extended Braking Distance , page 11.

Daily Inspections

Perform the following inspections each day before using the LineDriver ES Lithium.

- Check battery charge level. Charge if not fully charged.
- Inspect Coupler for excess movement. Adjust if needed. See **Coupler Adjustment**, page 16. Replace Coupler when it is no longer adjustable.
- Check function of the Seat Interlock Switch. The Seat Interlock Switch stops the ES Driver when the operator leaves the seat, and disables the Direction/Speed Pedals.
 - With the Parking/Emergency Brake ON, move the Power Switch to the ON position while standing next to the LineDriver ES.
 - Gently tap the Direction/Speed Pedals. The LineDriver ES should not attempt to travel.
 - Sit on the seat and gently tap the Direction/Speed Pedals. The unit should attempt to travel.
 - Service the Seat Interlock Switch if the LineDriver does not respond as described in steps b and c above.
- Test Parking/Emergency Brake function and adjustment.
 - Choose a flat open area. Accelerate unit to 3 mph (5 kph).
 - Cause the LineDriver ES to roll freely (freewheel) by moving the Power Switch to the OFF position.
 - Stop unit by applying Parking/Emergency Brake. To adjust brakes, see **Parking/Emergency Brake Adjustment or Replacement**, page 14.

Operation

Differences in Operation

The LineDriver ES Lithium operates differently than a gasoline powered LineDriver.

1. LineDriver ES rolls freely, especially on inclines, when the power is off. Set Parking/Emergency Brake before turning off.
2. Turn power on before releasing Parking/Emergency Brake.
3. Performance drops when the battery charge becomes low. When there is about one hour of runtime remaining, the Voltage Meter begins to flash. When the batteries are deeply discharged and the LineDriver ES is about to shut down, the buzzer sounds about once per second.
4. The response of the Direction/Speed pedals is softer. Learn this softer response before operating on a job site.

How to Operate

1. Sit on seat to actuate Seat Interlock Switch. Ensure Direction/Speed Pedals are not depressed.
2. Turn Power Switch ON. Buzzer will sound in a few seconds, indicating that the Direction/Speed Pedals are now active.
3. Disengage Parking/Emergency Brake on LineDriver and any brakes on attached equipment.
4. Squeeze hand control to release caster wheel of attached equipment.

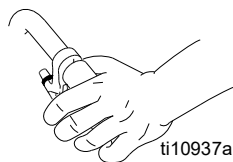

NOTE: LineDriver motion is forward and reverse. Turns are made with the striper or grinder.

5. Push striper or grinder handle bars to begin desired turn.

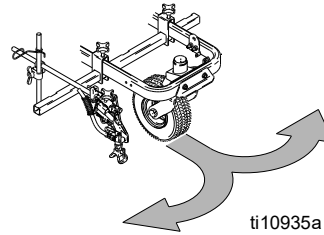

FREEWHEEL HAZARD				
Turning the Power Switch OFF will result in loss of drive power. Loss of drive power causes LineDriver to freewheel, which allows it to roll freely.				
<ul style="list-style-type: none"> Do not turn Power Switch OFF while LineDriver is in motion. If loss of drive power occurs while LineDriver is in motion, use the Parking/Emergency Brake to bring LineDriver to a stop. Always engage Parking/Emergency Brake before turning Power Switch OFF or standing up from seat. 				

6. Move Direction/Speed pedals to drive the LineDriver, as shown below. Switching from forward to reverse creates a braking action.

NOTE: LineDriver stops when both feet are removed from pedals.

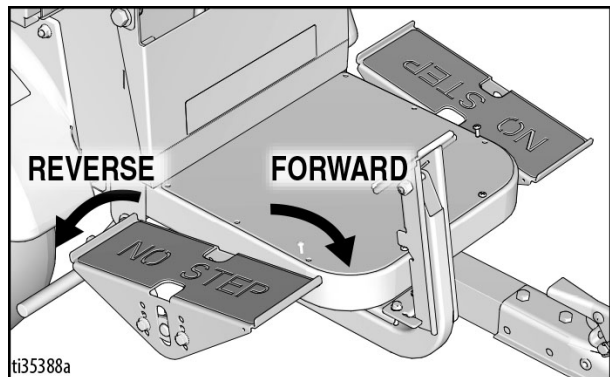

- Engage Parking/Emergency Brake when not operating LineDriver. This prevents rolling when on an incline.

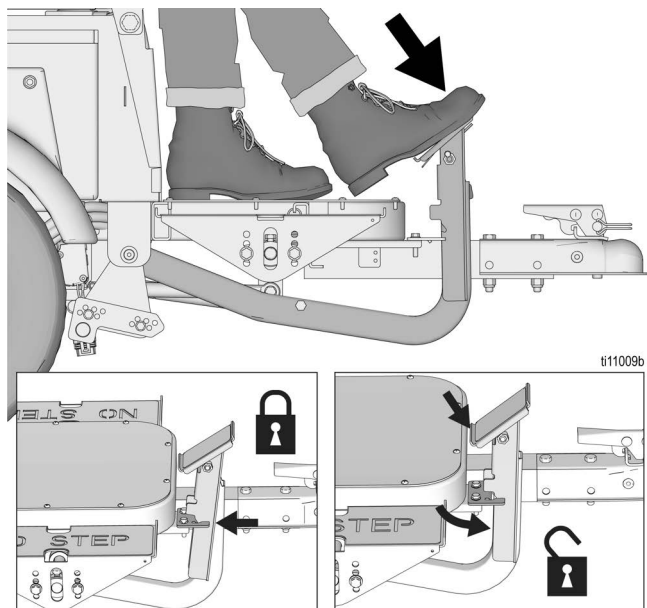

Operating on Inclines

Extended Braking Distance

Operating on inclines results in extended braking distances.

- Select Incline/ECO mode on Speed Switch when operating on inclines.
- Be prepared to use the Parking/Emergency Brake when operating on inclines.

NOTE: Do not operate on inclines greater than 7.5° (13%).



REDUCED BRAKING HAZARD

The braking from the Direction/Speed pedals can be significantly reduced when going down inclines at speeds over 6.5 mph (10 kph). This reduced braking results in longer braking distance than normal, which could lead to an accident.

A continuous buzzer alarm will sound when this reduced braking condition occurs. If this alarm sounds, apply the Parking/Emergency Brake to slow down. Failure to do so could result in serious injury.

- Do not drive in a manner that causes this alarm to sound.

Starting and Stopping on an Incline

- Engage the Parking/Emergency Brake before turning the Power Switch to OFF when parking on an incline.
- Turn the Power Switch to ON, and allow the machine to initialize before releasing the Parking/Emergency Brake when starting on an incline.

Trailer Loading & Unloading

NOTE: LineDriver ES rolls freely, especially on inclines, when the power is off. Set Parking/Emergency Brake before turning off. Turn power on before releasing Parking/Emergency Brake.

- Always keep LineDriver connected to striper or grinder.
- Use a level surface to load and unload. Leave sufficient space behind ramps.
- Use loading ramps of sufficient length and capable of handling weight of unit and operator.
- Adjust striper or grinder handlebar to highest position. Slide seat back as far as possible.

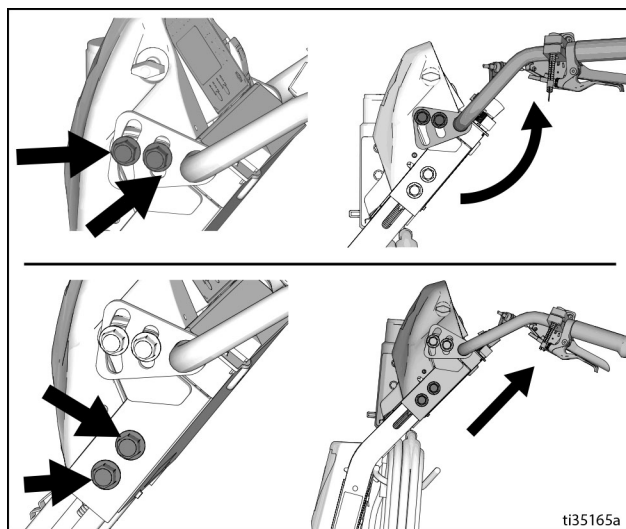

- Use right foot to engage Parking/Emergency Brake. Use left foot to control speed. Use ECO Mode to limit speed.
- Slowly drive straight up/down ramps (do not drive at an angle).
- Keep a firm grip on handlebars as the ramp is negotiated.

NOTE: Striper or grinder handlebars swing up/down as the ramp is engaged/disengaged. Keep legs clear.

Charging the Batteries



Replace and charge battery only in well-ventilated area and away from flammable or combustible materials, including paints and solvents. The charger may become hot while charging. Do not touch. Refer to Charger Manual for additional information.

The charger may be used any time the LineDriver is not being used. When the batteries are fully charged, the charger automatically stops.

Batteries are 50% charged when leaving the factory. Due to self-discharging of the battery, charge battery before first use. It takes ~10-12 hours to charge a fully depleted battery, and ~4 hours to charge the battery 3/4 full.

NOTE: Battery life depends on the depth of discharge per cycle. A battery that is discharged to 50% depth will get over twice as many cycles in its life compared to it being discharged to 100% depth each cycle.

1. Place unit in dry, well-ventilated area and away from flammable or combustible materials, including paints and solvents.
2. Position the driver so the wheels are on a true grounded surface, not on pavement.
3. Ensure Power Switch is in **OFF** position.

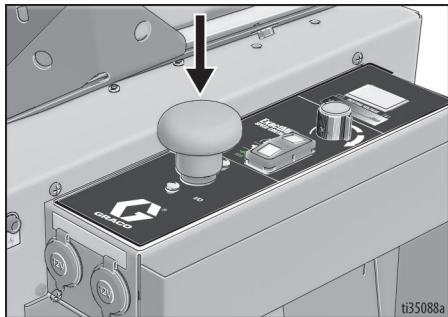

4. Use your smartphone's camera to scan and download the Power Sonic Quick Guide and Battery App to check the battery level.

POWERSONIC
TRUSTED BATTERY SOLUTIONS

SMART BATTERY

LEARN MORE ABOUT THE LITHIUM BLUETOOTH BATTERY SERIES

 Quick Guide

 App Download

5. Plug charging cord into charging port on the unit. Connect an extension cord, per charger manual, to the charging cord and plug it into wall power.
6. **Always unplug the battery charger when the batteries reach full charge.**



This equipment must be grounded to reduce the risk of static sparking and electric shock. An electric shock or static spark can cause fumes to ignite or explode. An improper ground can cause electric shock. A good ground provides an escape wire for the electric current.

Always use an outlet that is properly installed and grounded in accordance with all local codes and ordinances.

Do not modify the plug provided; if it does not fit the outlet, have the proper outlet installed by a qualified electrician.

Power Requirements

- All models use the same battery charger. Refer to **Technical Specifications**, page 37, for power requirements.

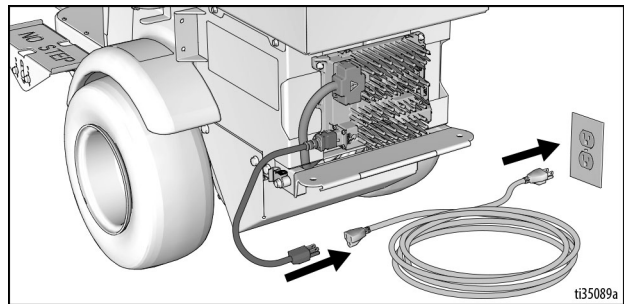

Battery Maintenance

- Charging – always unplug charger after 24 hours.
- Storage – never leave the battery charger plugged into wall power during storage. For optimal battery life, don't allow battery to get below 20% SOC (state of charge).
- In long-term storage applications, a lithium battery should not be stored at 100% SOC. Store between 30-70% SOC.
- Recommended long-term storage temperature: 59° to 95°F (15° to 35°C).

7. The Charging Output Indicator means that the charger output is active.
8. When power is connected, charger will immediately begin charging.

NOTE: Battery will charge to ~30 volts while charging and then it will come back down to ~27 volts after fully charging.

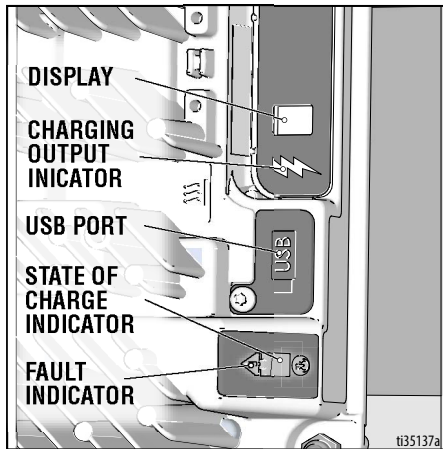

NOTE: The Charge Display may show codes to indicate different conditions. **Refer to charger manual for additional information.**

- 'F' codes meaning that an internal fault condition has caused charging to stop.
 - 'E' codes meaning that an external error condition has caused charging to stop.
9. When battery charge indicator is solid green, the charge is complete.

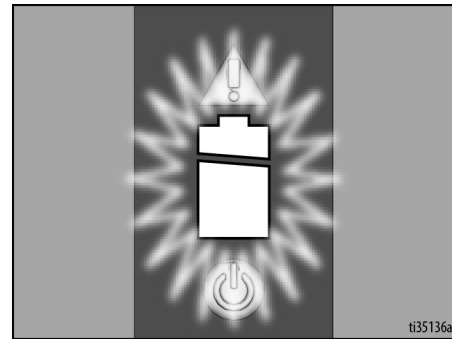

Maintenance

Parking/Emergency Brake Adjustment or Replacement

1. Block tires so LineDriver will not move. Release Parking/Emergency Brake.
2. Ensure Power Switch is in OFF position.
3. Inflate tires to operating pressure per tire sidewall. Remove two bolts securing brake rod.

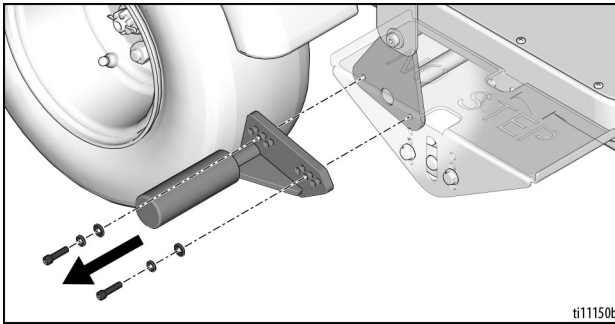

4. Select a hole pattern that positions the brake rod 1/8 to 1/4 in. from the tire.

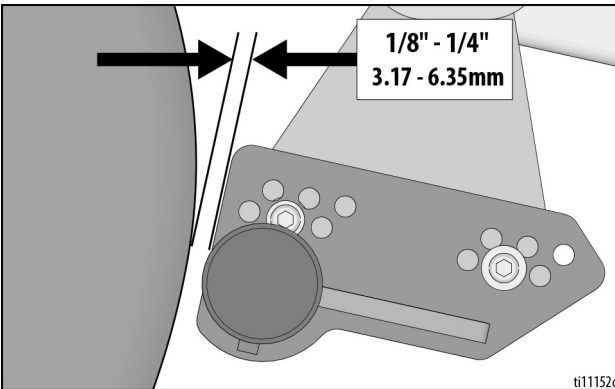
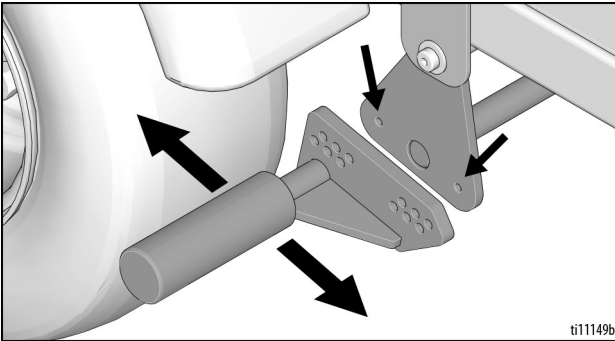

5. Install two bolts and secure brake rod. Repeat for second tire.

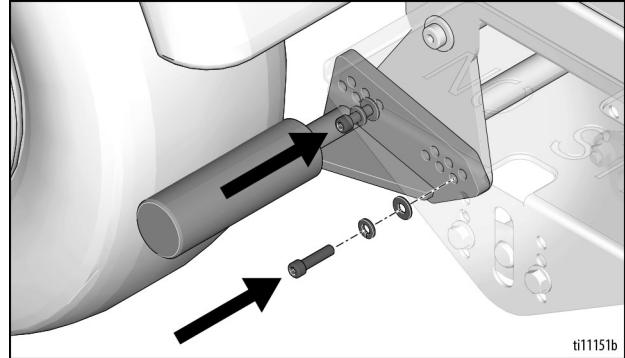

NOTE: Brake rods are not interchangeable from side to side. Model shown in the graphic above is the right side version.

Throttle Linkage Adjustment

**LineDriver creeps in forward or reverse direction
(with no pressure on speed pedals)**

NOTE : Always turn the main power switch off except when it needs to be on to check operation.

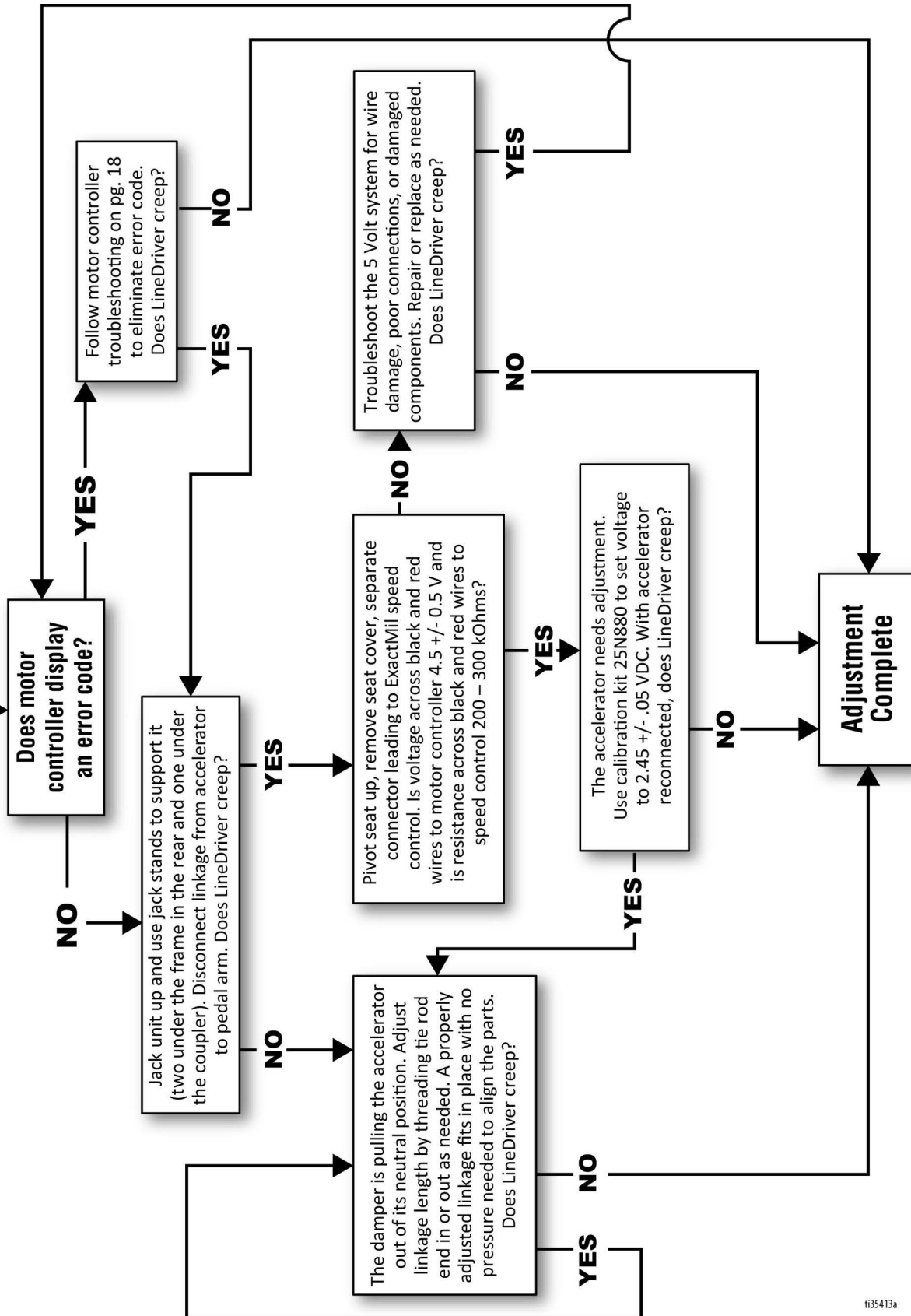

t35413a

Coupler Adjustment

A Coupler too tight or too loose needs to be adjusted.

Ensure Power Switch is in OFF position.

Before adjusting, check ball and Coupler for wear.

Replace entire Coupler if unable to tighten it.

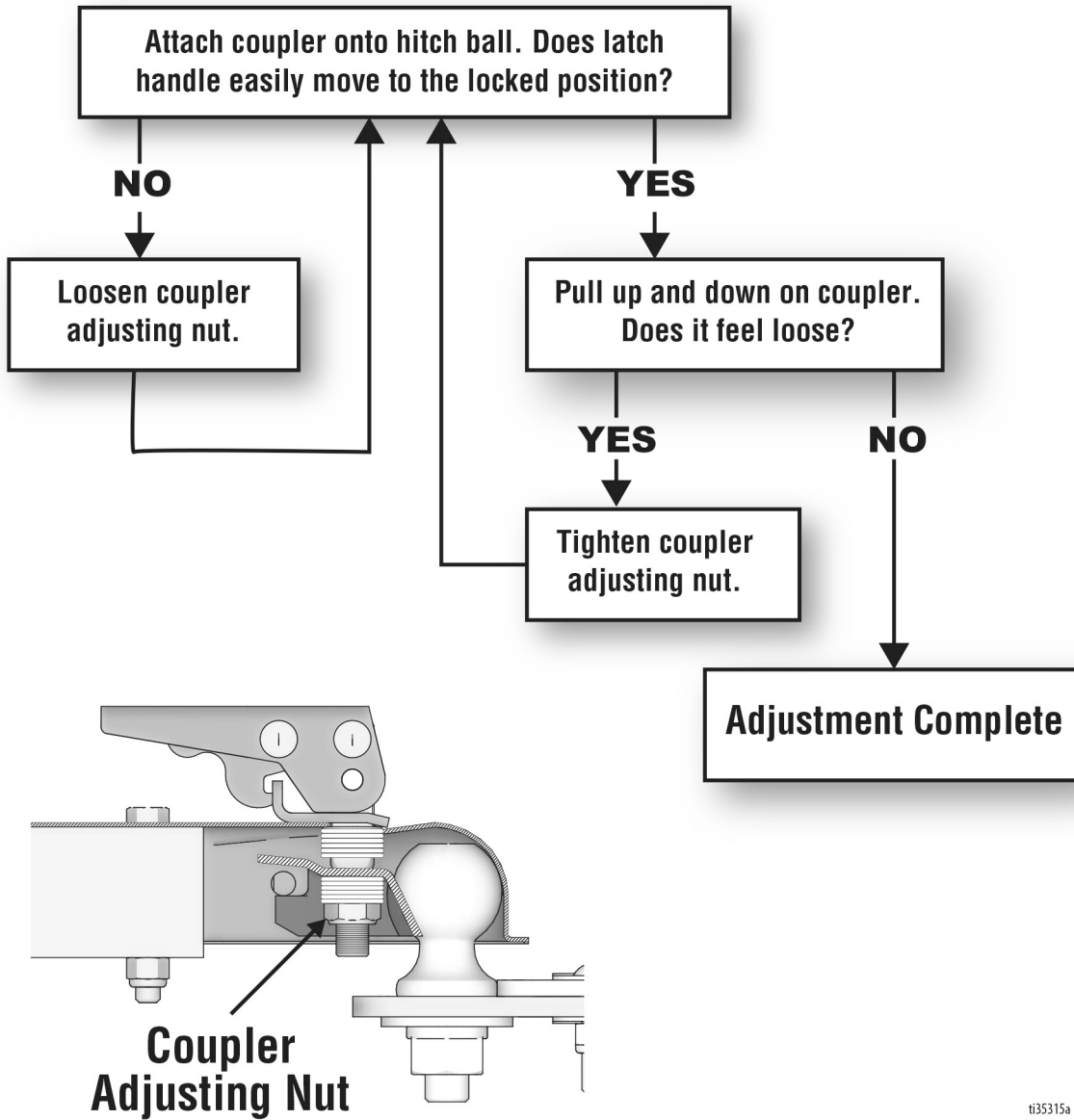

t35315a

Accelerator Calibration (Using Kit 25N880)

1. Turn power OFF. Engage Parking/Emergency Brake.
2. Slowly raise hitch Coupler until LineDriver rests on rear bumper.
3. Remove accelerator from LineDriver.
4. Connect calibration cable per illustration. Use a Digital Multi-Meter to measure volts DC.
5. Mount accelerator to calibration plate and plate to pedal. This makes it easier to torque fasteners.
6. Ensure nothing is on the operator's seat so the Seat Interlock Switch prevents wheel movement. Turn power ON.
7. Loosen adjustment fastener and set neutral position voltage to $2.45 \pm .05$ volts. Use calibration plate to hold accelerator in this position. Torque adjustment fastener to 90-100 in-lbs.
8. Rotate accelerator arm back and forth, then return it to neutral position. Re-adjust voltage if necessary. Turn power OFF.
9. Install accelerator onto LineDriver. When connecting linkage, adjust tie rod end so no pressure is needed to align parts. Otherwise the LineDriver will creep.
10. LineDriver may creep forward or reverse when turned on. As a precaution, jack unit up and use jack stands to support it (two under the frame in the rear and one under the Coupler).
11. Connect the LineDriver to a striper or grinder, sit on the seat and turn on. If wheels do not turn (with no pressure on speed pedals), calibration is complete. If they do turn, follow **Throttle Linkage Adjustment**, page 15.

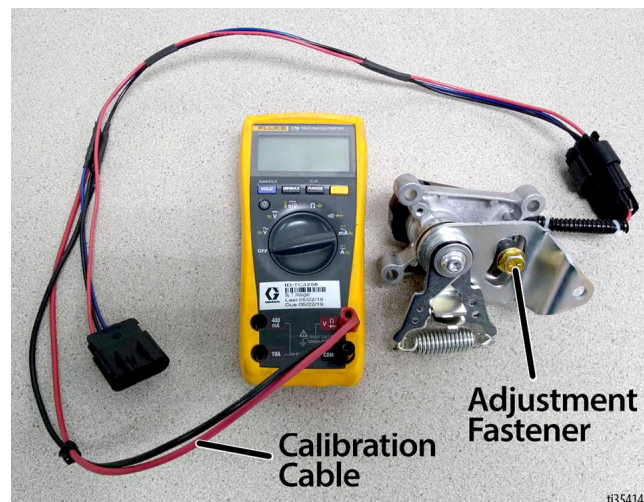
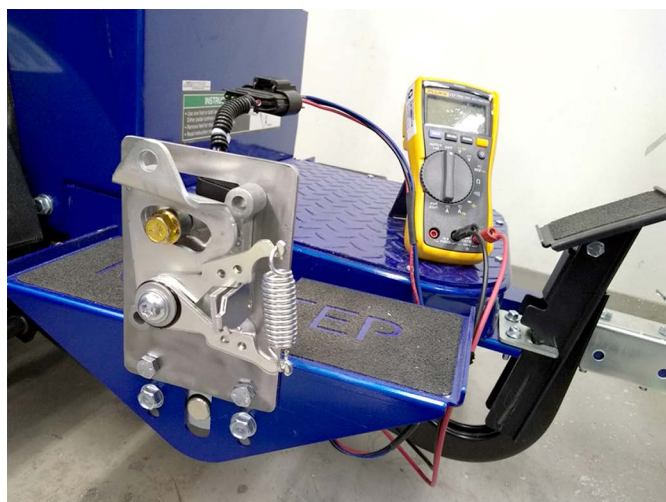

Transaxle Service

Check Oil Level (Annually)

1. Turn power OFF. Engage Parking/Emergency Brake.
2. Slowly raise hitch Coupler until LineDriver rests on rear bumper.

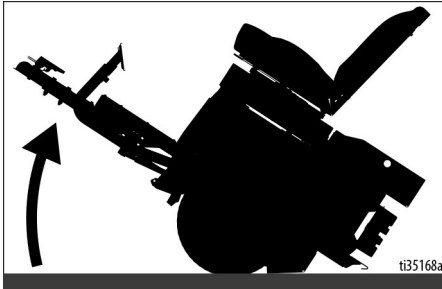

3. Remove fill plug from transaxle cover.

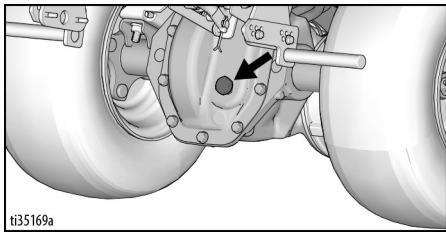

4. Slowly lower hitch Coupler. Oil will begin to flow out of transaxle when hitch Coupler is lowered to 10.5 - 12.5" from the floor. Add or remove oil as needed.

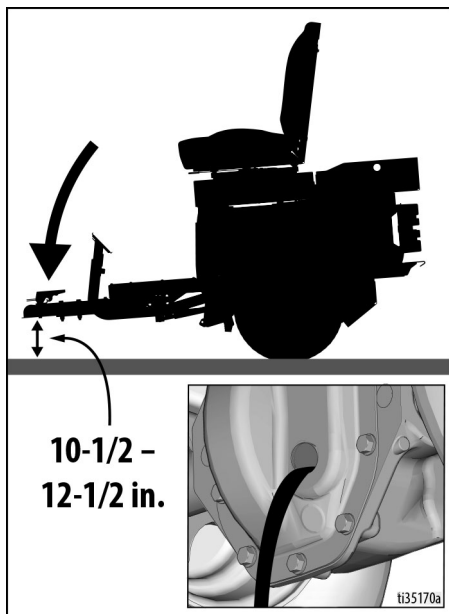

5. Reinstall plug.

Change Oil (recommended every 3 years)

1. Turn power OFF. Engage Parking/Emergency Brake.
2. Slowly raise hitch Coupler until LineDriver rests on rear bumper.
3. Place pan under transaxle cover. Remove screws and cover.

NOTE: Sealant may hold cover on. If necessary, pry cover off.

4. Allow oil to drain completely. Follow local ordinances and regulations for disposal.
5. Clean cover and housing where sealant is used. Apply new sealant (recommended is RTV silicone).
6. Reinstall cover with screws.
7. Remove drain plug. Fill with 22 oz. of Mobilfluid™ 424.
8. Check oil level per above. Reinstall plug.
9. Check for oil leaks. Fix if necessary.

Repair

Battery Pack Replacement

NOTE: Prior to replacing batteries, refer to **Troubleshooting - LineDriver**, page 22, to determine if the batteries are the cause of the problem. Never mix battery types or brands. A new battery can be mixed with older batteries. The LineDriver ES ships with three lithium batteries, however, a fourth battery can be added for additional run time between charge.

1. Turn Power Switch OFF. Turn lights OFF. Disconnect 12V accessories. Unplug the battery charging cord.
2. Remove Tool Tray.
3. Remove rear screws of Seat Lid.
4. Pivot Operator Seat forward slowly.

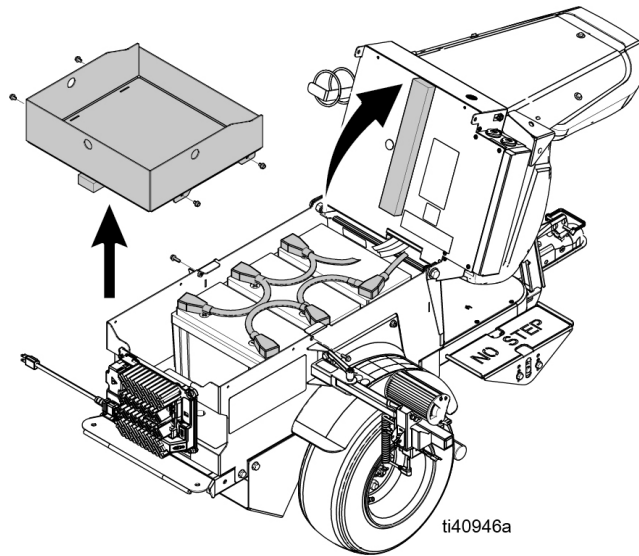

5. Remove battery cables. Always disconnect negative (black) cables prior to disconnecting positive (red) cables.

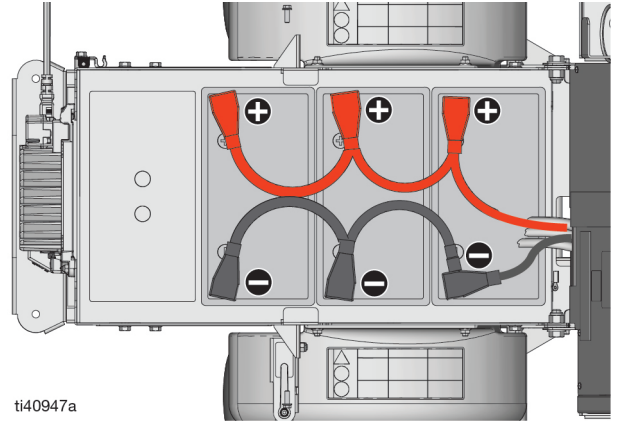

6. Remove batteries and recycle according to below.

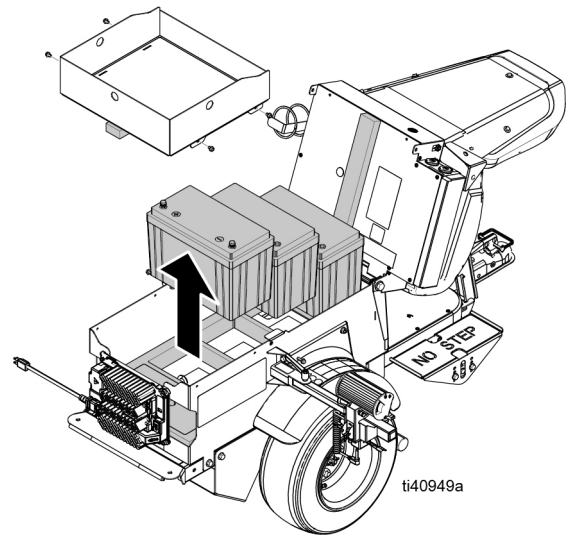

7. Install new batteries. Install cables positive to positive and negative to negative. To prevent battery terminal short circuit, always connect the positive (red) cables prior to connecting negative (black) cables.
8. Reinstall seat and Tool Tray.
9. Charge batteries. See **Charging the Batteries**, page 12.

Transaxle Replacement

1. Turn power OFF.
2. Remove rear screws of Seat Lid. Pivot seat forward slowly.
3. Disconnect battery cables to motor controller.
4. Jack unit up and use jack stands to support unit (two jacks at the rear and one jack in the front). Raise wheels about 2 inches off the floor, leaving enough room to pull the transaxle out.
5. Remove wheels.
6. Remove motor cover.
7. Disconnect wires attached to motor.
8. Place a support under motor and remove transaxle.
9. Place new transaxle under unit. Lay motor wires on transaxle.
10. Bolt new transaxle to frame.
11. Connect wires to motor. Take care when attaching the three large cables to prevent damage to the plastic terminal block on the motor.
12. Install motor cover.
13. Install wheels.
14. Lower unit to the floor and reconnect the battery cables.
15. Reinstall Operator Seat.

Traction Motor Replacement

Follow **Transaxle Replacement**, page 20.

Motor Controller Replacement

1. Turn power OFF.
2. Remove rear screws of Seat Lid. Pivot seat forward slowly.
3. Disconnect battery cables to motor controller. Tape over terminals to prevent accidental contact.
4. Remove Seat Cover to expose motor controller.
5. Disconnect wires from motor controller.
6. Remove nuts holding motor controller in place.
7. Install new motor controller.
8. Connect wires to new motor controller. Be sure 35 pin connector latches.
9. Install Seat Cover.
10. Reconnect battery cables. Pivot seat back and reinstall rear screws of Seat Lid.
11. LineDriver may creep forward or reverse when turned on. As a precaution, jack unit up and use jack stands to support it (two under the frame in the rear and one under the Coupler).
12. Sit on the seat and turn on. If wheels turn with no pressure on speed pedals, follow the **Accelerator Calibration Procedure**, page 17.

Motor Replacement: Series A to Series B

1. Follow seps 1-8 of the **Transaxle Replacement**, page 20.
2. Use 2001834 screws in kit PN 18H262 to mount motor to transaxle, follow torque specifications on page 30.
3. Place transaxle under unit. Lay motor wires on transaxle.
4. Bolt transaxle to frame.
5. Connect wire to motor using PN 2002461 adapter harness. Take care when attaching the three large cables to prevent damage to the plastic terminal block on the motor.
6. Follow steps 12-15 of the **Transaxle Replacement**, page 20.
7. Follow **Motor Controller Replacement**, page 20.

Recycling and Disposal

Rechargeable Battery Disposal

Do not place batteries in the trash. Recycle batteries according to local regulations. In the USA and Canada, call 1-800-822-8837 to find recycling locations or go to www.call2recycle.org.

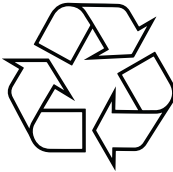

End of Product Life

At the end of the product's useful life, dismantle and recycle it in a responsible manner.

- Perform the **Pressure Relief Procedure**.
- Drain and dispose of fluids according to applicable regulations. Refer to the material manufacturer's Safety Data Sheet.
- Remove motors, batteries, circuit boards, LCDs (liquid crystal displays), and other electronic components. Recycle according to applicable regulations.
- Do not dispose of batteries or electronic components with household or commercial waste.
 - 
- Deliver remaining product to a recycling facility.

Troubleshooting - LineDriver

PROBLEM	CAUSE	SOLUTION
Parking/Emergency Brake does not keep LineDriver from moving	Parking Brake needs adjustment	Adjust Parking Brake
	Tire pressure too low	Adjust pressure per tire sidewall
LineDriver creeps in forward or reverse direction	Throttle linkage too long or too short	Adjust throttle linkage
Head light does not turn on	Connections	Repair connections
	LED	Replace light
	Open 10 amp fuse	Address cause of high current Replace fuse
	Switch	Replace switch
LineDriver does not move forward or reverse - Voltage Meter ON	Batteries discharged / go to battery app	Charge batteries at least 2 hours
	Seat Interlock Switch	Sit on seat
	Speed pedals engaged while turning unit on	Disengage pedals then turn unit on
	Speed pedals engaged for 15 seconds with no LineDriver movement	Turn Power Switch OFF then back ON to reset motor controller
	Motor Controller fault	Follow Troubleshooting - Motor Controller instructions, page 23
LineDriver does not move forward or reverse - Voltage Meter OFF	Batteries discharged	Charge batteries at least 2 hours
	Power Switch OFF	Pull knob up
	Open 20 amp fuse	Address cause of high current Replace fuse
	Open 300 amp fuse	Address cause of high current Replace fuse
LineDriver only moves slowly	Parking/Emergency Brake engaged	Disengage Parking/Emergency Brake
	Batteries discharged	Charge batteries at least 2 hours
	ExactMil™ Speed Control ON	Increase speed setting or turn OFF
	ECO Mode ON	Turn OFF
	Motor Controller fault	Follow Troubleshooting - Motor Controller instructions, page 23
Battery charger not charging	Batteries already charged	Charge batteries after voltage drops below 25.0V
	Charger has error or fault code	Clear code. See charger manual
Batteries discharge within 6 hours of usage (even when charged overnight)	Parking/Emergency Brake engaged	Disengage brake while operating
	Wheels rubbing	Clear material away from wheels
	Go to battery app	Replace failed battery
	Charger has error or fault code	Clear code. See charger manual
Hitch Coupler too tight to latch or too loose after latching	LineDriver hitch Coupler too loose or tight on ball	Adjust Coupler
Voltmeter flashes ON/OFF	Batteries discharged and less than one hour of runtime left	Charge batteries at least 2 hours
Buzzer sounds continuously when traveling over 6.5 mph (10 kph).	Braking from Direction/Speed Control pedals is significantly reduced.	Slow down. Apply Parking/Emergency Brake as needed.

Troubleshooting - Motor Controller

Diagnostics

Diagnostics information can be obtained by observing the fault codes issued by the Status LEDs. See Table 1 for a summary of LED display formats.

The pair of LEDs built into the controller (one red, one yellow) produce flash codes displaying all the currently set faults in a repeating cycle. Each code consists of two digits. The red LED flashes once to indicate that the first digit of the code will follow; the yellow LED then flashes the appropriate number of times for the first digit. The red LED flashed twice to indicate that the second digit of the code will follow; the yellow LED flashes the appropriate number of times for the second digit.

Example:

B+ Under voltage Cutback (code 23) and Stall Detected (code 73).

The controller's two LEDs will display this repeating pattern:

Code	Display
23	One red, two yellow, two red, three yellow
73	One red, seven yellow, two red, three yellow

The numerical codes used by the yellow LED are listed in **Table 2**, page 24, which also lists possible fault causes and describes the conditions that set and clear each fault.

NOTE: If there are more than one errors active at one time, the control will cycle through them and repeat.

Summary of LED Display Formats

The two LEDs have four different display modes, indicating the type of information they are providing.

Table 1

Display	Status
Neither LED illuminated	Controller is not powered on, or Vehicle has dead battery, or Severe damage
Yellow LED flashing	Controller is operating normally
Yellow and red LEDs both on solid	Controller is in Flash program mode
Red LED on solid	Internal hardware fault detected by the Supervisor or Primary microprocessor. Missing or corrupt software. Interrupting a software download may cause corruption of the software. Cycle Power Switch to clear. Reload software or replace controller if necessary.
Red LED and yellow LED flashing alternately	Controller has detected a fault. 2-digit code flashed by yellow LED identifies the specific fault; one or two flashes by red LED indicate whether first or second code digit will follow.

NOTE: When a fault is encountered, shut off the Power Switch and turn it back on to see if the fault clears. If it does not, shut off the Power Switch and remove the 35-pin connector. Check the connector for corrosion or damage, clean if necessary, and re-insert connector. If the fault persists, follow the instructions below. When inspecting a cable, always check for a loose terminal fastener, a loose crimp, corrosion, and connector or insulation damage. Repair or replace components as needed.

Table 2

CODE	DESCRIPTION	POSSIBLE CAUSE	SET / CLEAR CONDITIONS	SOLUTION
12	Controller Overcurrent	<ol style="list-style-type: none"> External short of phase U, V, or W motor connections. Controller defective. 	<p><i>Set:</i> Phase current exceeded the current measurement limit.</p> <p><i>Clear:</i> Cycle Power Switch.</p>	<ol style="list-style-type: none"> Inspect motor cables U,V,W. Visually inspect motor terminal block for external short circuit. Measure resistance between U, V, W cables and frame of motor. If resistance is less than 1 megohm, replace motor or controller.
13	Current Sensor Fault	<ol style="list-style-type: none"> Leakage to vehicle frame from phase U, V, or W (short in motor stator). Controller defective. 	<p><i>Set:</i> Controller current sensors have invalid offset reading.</p> <p><i>Clear:</i> Cycle Power Switch.</p>	<ol style="list-style-type: none"> Inspect motor cables U,V,W. Visually inspect motor terminal block for external short circuit. Measure resistance between U, V, W cables and frame of motor. If resistance is less than 1 megohm, replace motor or controller.
14	Pre-charge Failed	<ol style="list-style-type: none"> External load on battery pack (B+ connection terminal) that prevents the controller from charging. 	<p><i>Set:</i> The pre-charge failed to charge the capacitor bank.</p> <p><i>Clear:</i> Cycle Power Switch.</p>	<ol style="list-style-type: none"> Inspect all cables and connectors from batteries to controller. Remove any after market devices that could draw power during system power up. Only use designated auxiliary ports for after market devices.
15	Controller Severe Undertemp	<ol style="list-style-type: none"> Controller is operating in an extreme environment. 	<p><i>Set:</i> Heatsink temperature below -40°C.</p> <p><i>Clear:</i> Bring heatsink temperature above -40°C, and cycle Power Switch.</p>	<ol style="list-style-type: none"> Move the unit to a warmer area.
16	Controller Severe Overtemp	<ol style="list-style-type: none"> Controller is operating in an extreme environment. Excessive load on vehicle. Improper mounting of controller. 	<p><i>Set:</i> Heatsink temperature above +95°C.</p> <p><i>Clear:</i> Bring heatsink temperature below +95°C, and cycle Power Switch.</p>	<ol style="list-style-type: none"> Move the unit to a cooler area. Reduce operating load on vehicle. Inspect controller heatsink mounting for air gaps and tighten fasteners.

CODE	DESCRIPTION	POSSIBLE CAUSE	SET / CLEAR CONDITIONS	SOLUTION
17	Severe B+ Undervoltage	<ol style="list-style-type: none"> 1. Non-controller system drain on battery. 2. Battery resistance too high. 3. Battery disconnected while driving. 4. Open B+ fuse or main contractor did not close 	<p><i>Set:</i> Battery pack voltage dropped below the Severe Undervoltage limit with FET bridge enabled.</p> <p><i>Clear:</i> Bring battery pack voltage above Severe Undervoltage limit.</p>	<ol style="list-style-type: none"> 1. Inspect all cables and connectors from batteries to controller. 2. Let battery cool then fully recharge battery. If error happens again, load test battery and replace if needed. 3. Inspect 300 amp fuse and replace if open. 4. Inspect contactor for corroded contacts and replace if needed.
	Severe Power Switch Undervoltage	<ol style="list-style-type: none"> 1. Non-controller system drain on battery/Power Switch circuit wiring. 2. Power Switch disconnected while driving. 3. Open 20 amp fuse. 	<p><i>Set:</i> Below Brownout Voltage for 2 seconds.</p> <p><i>Clear:</i> Bring Power Switch voltage above Brownout Voltage.</p>	<ol style="list-style-type: none"> 1. Inspect all Power Switch cables and connectors. 2. Inspect 20 amp fuse and replace if open.
18	Severe B+ Overvoltage	<ol style="list-style-type: none"> 1. Battery resistance too high for given regen current. 2. Battery disconnected while regen braking. 	<p><i>Set:</i> Battery pack voltage exceeded the Severe Overvoltage limit with FET bridge enabled.</p> <p><i>Clear:</i> Bring battery pack voltage below Severe Overvoltage limit, and then cycle Power Switch.</p>	<ol style="list-style-type: none"> 1. Let battery cool then fully recharge battery. If error happens again, load test batteries and replace if needed. 2. Inspect all cables and connectors from batteries to controller.
	Severe Power Switch Overvoltage	<ol style="list-style-type: none"> 1. Incorrect (too high) battery-voltage applied to Power Switch (pin 1). <p>NOTE: Prevents Main Contactor closure if Power Switch is greater than the Severe Overvoltage limit.</p>	<p><i>Set:</i> Power Switch voltage exceeded Severe Overvoltage limit.</p> <p><i>Clear:</i> Bring Power Switch voltage below the Severe Overvoltage limit.</p>	<ol style="list-style-type: none"> 1. Check the voltage of each 24V battery with a digital volt meter. Inspect Power Switch and battery wiring for insulation damage and proper wiring.
22	Controller Overtemp Cutback	<ol style="list-style-type: none"> 1. Controller is performance-limited at this temperature. 2. Controller is operating in an extreme environment. 3. Excessive load on vehicle. 4. Improper mounting of controller. 	<p><i>Set:</i> Heatsink temperature exceeded 85°C.</p> <p><i>Clear:</i> Bring heatsink temperature below 85°C.</p>	<ol style="list-style-type: none"> 1. Move the unit to a cooler area. 2. Reduce operating load on vehicle. 3. Inspect controller heatsink mounting for air gaps and tighten fasteners.
23	B+ Undervoltage Cutback	<ol style="list-style-type: none"> 1. Normal operation. Fault indicates the batteries need recharging. Controller is performance limited at this voltage. 2. Battery resistance too high. 3. Battery disconnected while driving. 4. Open 300 amp fuse or main contactor did not close. 5. Non-controller system drain on battery. 	<p><i>Set:</i> Battery pack voltage dropped below the Undervoltage limit with the FET bridge enabled.</p> <p><i>Clear:</i> Bring battery pack voltage above the Undervoltage limit (19V).</p>	<ol style="list-style-type: none"> 1. Charge batteries. 2. Let battery cool then fully recharge battery. If error happens again, load test batteries and replace if needed. 3. Inspect all cables and connectors from batteries to controller. 4. Inspect 300 amp fuse and replace if needed. 5. Inspect contactor for damaged, corroded or contaminated contacts. Repair or replace as needed.

CODE	DESCRIPTION	POSSIBLE CAUSE	SET / CLEAR CONDITIONS	SOLUTION
24	B+ Overvoltage Cutback	<ol style="list-style-type: none"> Normal operation. Fault shows that regen braking currents elevated the battery voltage during regen braking. Controller is performance limited at this voltage. Battery disconnected while regen braking. 	<p><i>Set:</i> Battery pack voltage exceeded the Overvoltage limit. <i>Clear:</i> Bring battery pack voltage below the Overvoltage limit (30V).</p>	<ol style="list-style-type: none"> Continue using the unit. Inspect all cables and connectors from batteries to controller.
25	+5V Supply Failure	<ol style="list-style-type: none"> Bad crimps or faulty wiring. Shorted motor encoder. Shorted throttle. Shorted ExactMil potentiometer. 	<p><i>Set:</i> +5V supply (pin 26) outside the 5 V±10% range. <i>Clear:</i> Bring voltage within range.</p>	<ol style="list-style-type: none"> Inspect motor encoder/thermistor cable and connector. Disconnect motor encoder and cycle unit power. If the 5V supply fault clears, replace the motor. If the 5V supply fault persists, reconnect encoder and repeat this process for the throttle assembly and ExactMil potentiometer.
28	Motor Temp Hot Cutback	<ol style="list-style-type: none"> Motor temperature is at or above the programmed Temperature Hot setting, and the current is being cut back. 	<p><i>Set:</i> Motor temperature is at or above the Temperature Hot parameter setting. <i>Clear:</i> Bring the motor temperature within range.</p>	<ol style="list-style-type: none"> Move to cooler area, reduce operating load.
29	Motor Temp Sensor Fault	<ol style="list-style-type: none"> Motor thermistor is not connected properly. 	<p><i>Set:</i> Motor thermistor input (pin 8) is at the voltage rail (0V or 10 V). <i>Clear:</i> Bring the motor thermistor input voltage within range.</p>	<ol style="list-style-type: none"> Inspect motor encoder/thermistor cable and connector.
31	Main Contactor Open/Short	<ol style="list-style-type: none"> Open or short across contractor coil. Dirty connector pins. Bad crimps or faulty wiring. 	<p><i>Set:</i> Main contactor driver (pin 6) is either open or shorted. This fault can be set only when Main Enable = ON. <i>Clear:</i> Correct open or short, and cycle Power Switch.</p>	<ol style="list-style-type: none"> Inspect contactor coil cables and connectors. Test the contactor coil and replace contactor if needed.
36	Encoder Fault	<ol style="list-style-type: none"> Motor encoder failure. Bad crimps or faulty wiring. 	<p><i>Set:</i> Motor encoder phase failure detected. <i>Clear:</i> Cycle Power Switch.</p>	<ol style="list-style-type: none"> Inspect motor encoder/thermistor cable and connector. Replace motor.
37	Motor Open	<ol style="list-style-type: none"> Motor phase is open. Bad crimps or faulty wiring. 	<p><i>Set:</i> Motor phase U, V, or W detected open. <i>Clear:</i> Cycle Power Switch.</p>	<ol style="list-style-type: none"> Inspect U, V, W cables. Replace motor.
38	Main Contactor Welded	<ol style="list-style-type: none"> Main contactor tips are welded closed. Motor phase U or V is disconnected or open. An alternate voltage path is bypassing the contractor between battery and B+ on the controller before the contractor engages. 	<p><i>Set:</i> Just prior to the main contactor closing, the battery pack voltage (B+ connection terminal) was loaded for a short time and the voltage did not discharge. <i>Clear:</i> Cycle Power Switch.</p>	<ol style="list-style-type: none"> Inspect contactor for welded contacts and replace if necessary. Inspect all cables from the battery pack to controller looking for insulation damage. Inspect U, V, W cables.

CODE	DESCRIPTION	POSSIBLE CAUSE	SET / CLEAR CONDITIONS	SOLUTION
39	Main Contactor Did Not Close	<ol style="list-style-type: none"> 1. Main contactor did not close. 2. Main contactor tips are oxidized, burned, or not making good contact. 3. External load on battery pack (B+ connection terminal) that prevents battery pack from charging. 4. Blown 300 amp fuse. 	<p><i>Set:</i> With the main contactor commanded closed, the battery pack voltage (B+ connection terminal) did not charge to B+.</p> <p><i>Clear:</i> Cycle Power Switch.</p>	<ol style="list-style-type: none"> 1. Inspect contactor cable and connectors. 2. Inspect all cables and connectors from batteries to controller. 3. Inspect contactor contacts for damage or corrosion and repair or replace contactor. 4. Inspect 300 amp fuse and replace if needed.
41	Throttle Open	<ol style="list-style-type: none"> 1. Throttle wiper voltage too high. 	<p><i>Set:</i> Throttle wiper (pin 16) voltage is higher than the high fault threshold.</p> <p><i>Clear:</i> Bring throttle wiper voltage below the fault threshold.</p>	<ol style="list-style-type: none"> 1. Inspect throttle cable insulation and connectors for damage and repair or replace where needed. 2. Replace throttle assembly.
42	Throttle Short	<ol style="list-style-type: none"> 1. Throttle wiper voltage too low. 	<p><i>Set:</i> Throttle wiper (pin 16) voltage is lower than the low fault threshold.</p> <p><i>Clear:</i> Bring throttle wiper voltage above the fault threshold.</p>	<ol style="list-style-type: none"> 1. Inspect throttle cable and connectors. 2. Replace throttle assembly.
47	HPD/Sequencing Fault	<ol style="list-style-type: none"> 1. Power Switch, seat, and throttle inputs applied in incorrect sequence. 2. Faulty wiring, crimps, or switches at Power Switch, seat, or throttle inputs. 	<p><i>Set:</i> HPD (High Pedal Disable) or sequencing fault caused by incorrect sequence of Power Switch, seat, and throttle inputs.</p> <p><i>Clear:</i> Reapply inputs in correct sequence (neutral throttle, power, seat switch).</p>	<ol style="list-style-type: none"> 1. Cycle power with no pressure on Speed Pedals. 2. If error persists, inspect throttle and seat switch cables. 3. Recalibrate the accelerator assembly. Refer to Accelerator Calibration, page 17. 4. Replace throttle assembly.
73	Stall Detected	<ol style="list-style-type: none"> 1. Stalled motor. 2. Motor encoder failure. 3. Bad crimps or faulty wiring. 4. Problems with power supply for the motor encoder. 	<p><i>Set:</i> No motor encoder movement detected.</p> <p><i>Clear:</i> Cycle Power Switch.</p>	<ol style="list-style-type: none"> 1. Reduce load on driver so it can move with applied throttle. 2. Inspect encoder/thermistor cable. Verify motor wires U, V, W are properly wired. 3. Replace motor. 4. Replace controller.
88	Encoder Pulse Count Fault	<ol style="list-style-type: none"> 1. Encoder Steps parameter does not match the actual motor encoder. 	<p><i>Set:</i> Detected wrong setting of the Encoder Steps parameter.</p> <p><i>Clear:</i> Cycle Power Switch.</p>	<ol style="list-style-type: none"> 1. Inspect motor encoder/thermistor cable. 2. Replace motor.

Parts Drawing



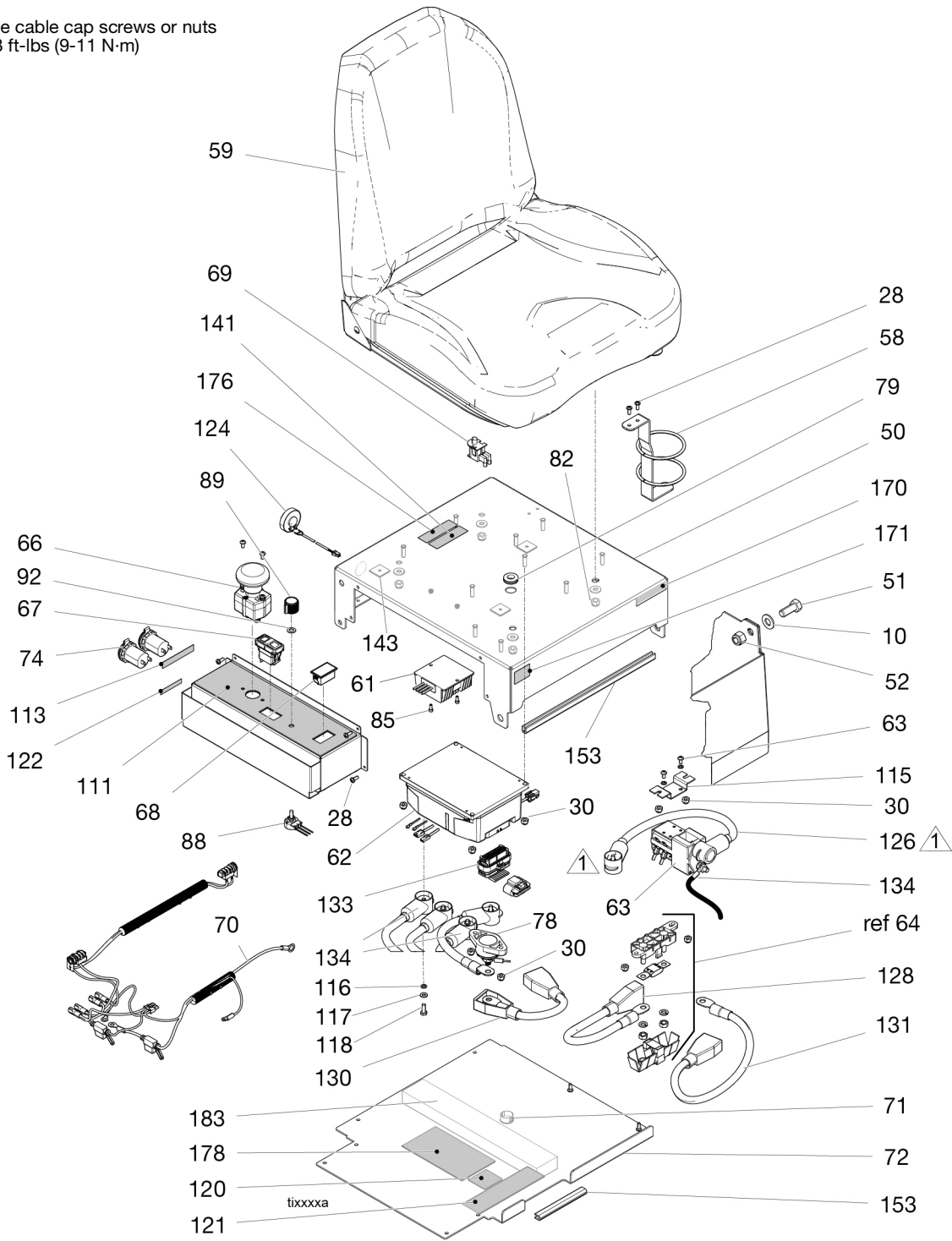

 Torque cable cap screws or nuts to 7-8 ft-lbs (9-11 N-m)

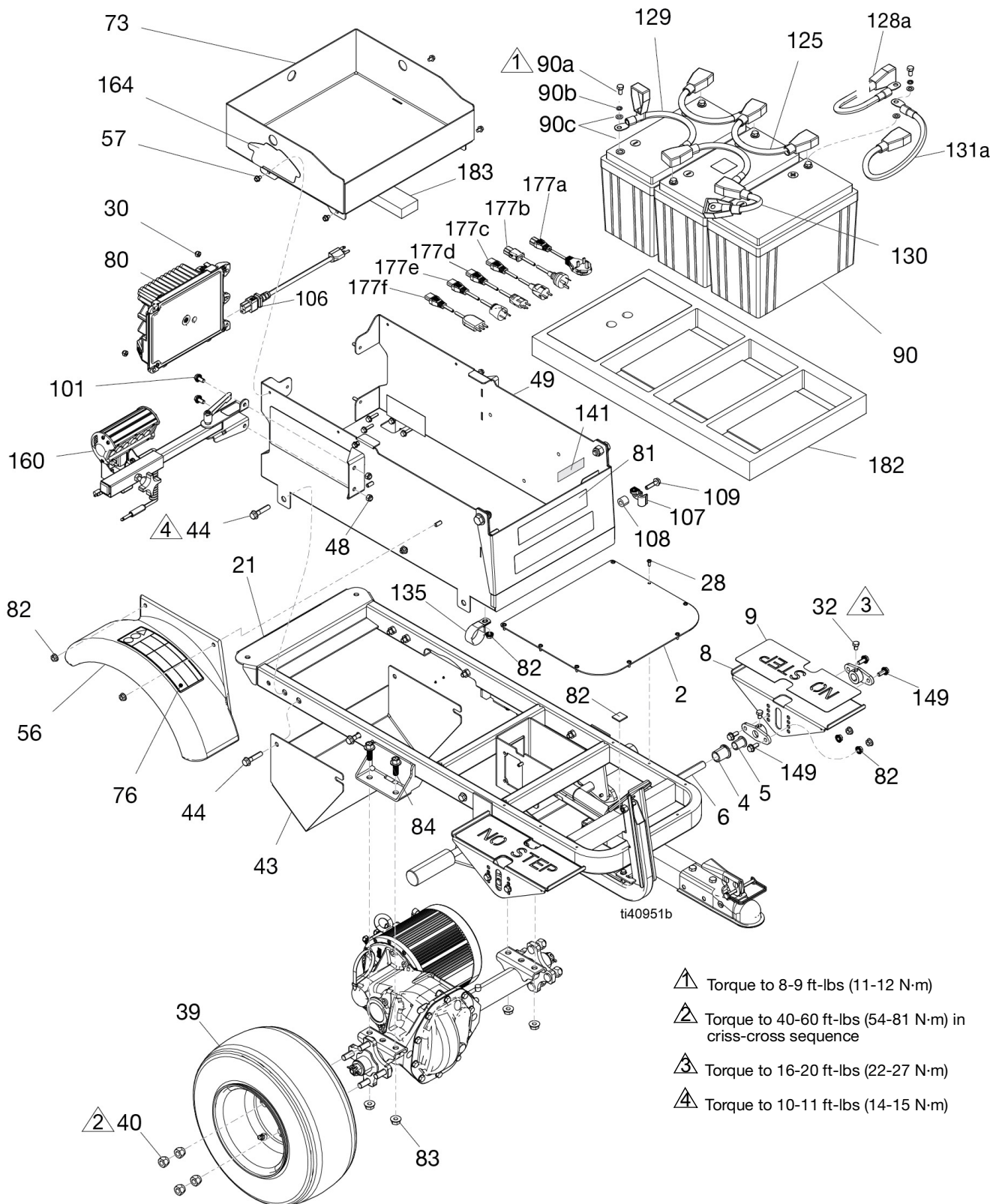

Parts Drawing



Parts Drawing - Detail Views

-  Torque to 6-7 ft-lbs. (8-9 N·m)
-  Torque to 20-25 ft-lbs (27-34 N·m)
-  Torque to 90-115 ft-lbs (122-156 N·m)
-  Torque to 95-105 in-lbs (10.7-11.9 N·m)

Use a wrench to support backup nuts firmly while tightening.

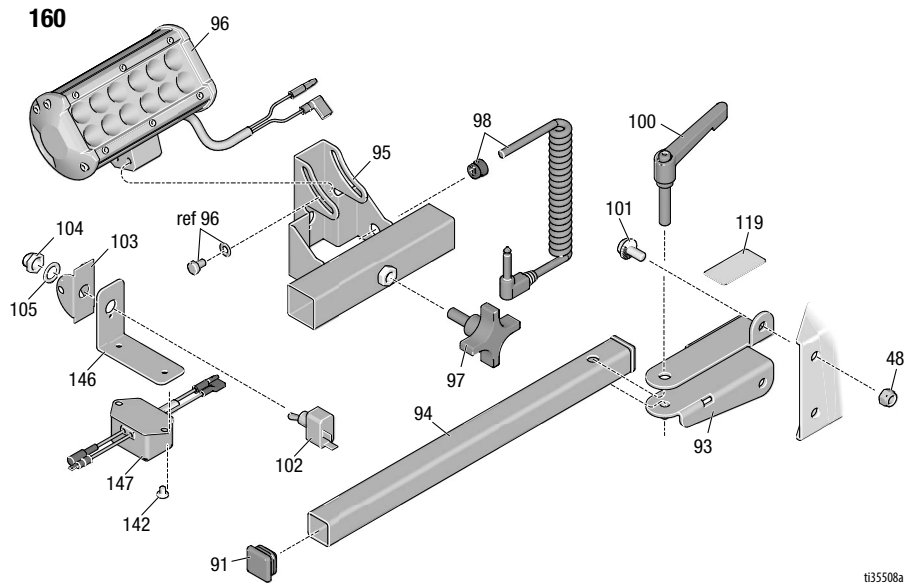
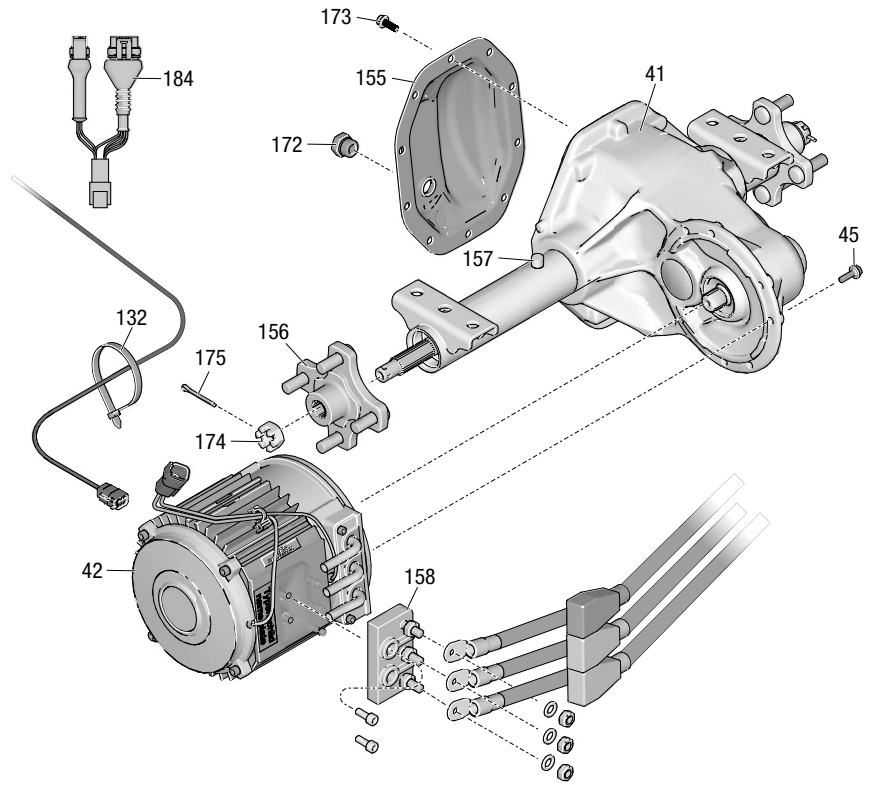

ti35508a

Parts List

Ref.	Part	Description	Qty	Ref.	Part	Description	Qty
1	25N649	FRAME, electric LineDriver	1	51	100424	SCREW, cap, hex hd	2
2	15N470	PLATE, floor	1	52	801020	NUT, lock, hex	2
3	25N776	KIT, throttle, <i>includes 180</i>	2	53	113796	SCREW, flanged, hex hd	2
4	15R872	INSERT, bearing, flange	2	54	25N477	BASE, controls, paint	1
5	116887	BEARING, flanged, bronze	2	56	17X959	FENDER	1
6	15R794	SHAFT, foot pedal	1	57	112798	SCREW, thread forming, hex hd	4
7	247901	PLATE, linkage	1	58	247544	HOLDER, bottle	1
8	25N760	PEDAL, foot, adjustment	2	59	245341	SEAT, <i>includes 69, 82 (x4)</i>	1
9	121234	PAD, non-slip, pedal	2	61	25N483	CONVERTER, power	1
10	109570	WASHER, plain	2	62†			1
11	116889	COUPLER, ball	1		19C163	MOTOR, controller, series B	
12	113696	PIN, ball coupler	1		2002466	MOTOR, controller, series A	
13	247571	BRACKET, brake	1	63	25N487	BATTERY, contactor	1
14	15R123	SPRING	1	64	17N816	HOLDER, fuse	1
15	15R068	LATCH, brake	1	65	131738	FUSE, 300 amp	1
16	247572	PEDAL, foot brake	1	66	25N482	SWITCH, push button, shut off	1
17	15R409	PAD, non-slip, brake	1	67	25N625	SWITCH, rocker	1
18	15R122	SPRING	1	68	17N638	METER, volt, digital	1
19	19B111	BRAKE, adjustment, right	1	69	116833	SWITCH, safety, seat	1
20	19B112	BRAKE, adjustment, left	1	70	25E406	CABLE, harness, 12 vdc supply	1
21	290159	LABEL, reflective	1	71	25N649	PLUG, panel	1
22	17C773	BALL, joint, rod end	2	72	25N475	COVER, seat, paint	1
23	17Z351	ROD, straight linkage	1	73	17X949	TRAY, tool	1
24	25N527	DAMPENER, pedal	1	74	17Y217	SOCKET, 12V	2
25	103746	NUT, jam, hex, 3/8-24	2	75	16P138	LABEL, energy source	2
26	104541	NUT, lock, M8	2	76▲	198918	LABEL, warning	2
27	15R472	FASTENER, hex hd, flanged	2	77	25N529	LABEL	2
28	110037	SCREW, mach, pnh	22	78	25N526	POST, distribution	1
29	125585	SCREW, cap, hex hd	4	79	16V700	GROMMET	1
30	102040	NUT, lock, hex	18	80	25N480	BATTERY, charger	1
31	100527	WASHER, plain	4	81	15T120	LABEL, instruction	1
32	121280	SCREW, cap, hex hd	6	82	110996	NUT, hex, flange hd	19
33	115348	SCREW, cap, 3/8-16 hex hd, 5/16-18	2	83	125943	NUT, serrated flange, 7/16-14	4
34	101566	NUT, lock, 3/8-16	2	84	17M849	BOLT, flange, serrated	4
36	121256	SCREW, shoulder, skt hd	2	85	103229	SCREW, cap sch	2
37	802127	SCREW, cap, hex hd	2	86	187797	SPACER, duct	1
38	110838	NUT, lock	2	87	17X783	ISOLATOR, hvlp	1
39	249083	WHEEL pneumatic, assy	2	88	17P951	POTENTIOMETER, assy	1
40	125481	NUT, wheel	8	89	17N957	KNOB, potentiometer	1
41	25N488	AXLE, transaxle, <i>includes 155, 156, 157, 172, 173, 174, 175</i>	1	90	25U602	BATTERY, lithium 24v, <i>includes 90a, 90b, 90c, 112</i>	3
42†	25N521	MOTOR, transaxle, <i>includes 158</i>	1	90a		M8x1.25x16mm cap screw	8
43	17Y182	GUARD, motor	1	90b		M8 lock washer	8
44	116780	SCREW, hexed, hd, flanged	8	90c		M8 flat washer	16
45†	2001834	SCREW, hex flange, M6	6	91	116895	CAP, tube, square	2
47	100521	SCREW, cap, hex head	2	92	17X783	WASHER, nylon	1
48	111040	NUT, lock, insert, nylock, 5/16	4	93	15R063	BRACKET, light	1
49	25N471	CARRIAGE	1	94	15R064	SUPPORT, light	1
50	25N476	LID, seat, paint	1	95	17R099	TUBE, bracket, light, LED	1
				96	17R098	LIGHT, LED	1

Ref.	Part	Description	Qty	Ref.	Part	Description	Qty
97	111145	KNOB, pronged	1	157	17Z072	AXLE, vent, cap	1
98	114425	BUSHING, strain relief	1	158	17Z073	KIT, terminal, block	1
99	15R308	CORD, power	1	159	25N762	KIT, transaxle, assembly, <i>includes 41, 42, 45</i>	1
100	15R864	KNOB	1	160	25N778	KIT, LineDriver ES light	1
101	111800	SCREW, cap, hex hd	2	161	25N787	KIT, hitch	1
102	111930	SWITCH, toggle	1	161a	17Z155	BRACKET, hitch mount	1
103	107255	GUARD, switch	1	161b	17Z156	BRACKET, hitch brace	1
104	195428	BOOT, toggle	1	161c	17Z209	BOLT, button HD, 3/8-16 x 2.75	2
105	105658	RING, locking	1	161d	129602	SCREW, cap, button hd, 3/8 x 1.75	2
106	17N758	CORD, power, 125V, US	1	161e	116913	BALL, trailer	1
107	278204	CLIP, drain line	1	161f	108851	WASHER, plain	8
108	129627	SPACER, nylon, 3/8 ID	1	161g	101566	NUT, lock	4
109	15C753	SCREW, mach, hex wash hd	1	161h	110947	WASHER, plain	1
111	17Y311	LABEL, controls	1	164	25U745	LABEL	2
113	17Y313	LABEL, max wattage	1	170	17P925	LABEL, A+ service	1
115	17Y315	BRACKET, contactor	1	171	16D576	LABEL, made in USA	1
116	117018	WASHER	5	172	120765	FITTING, plug	1
117	108050	WASHER, lock, spring	5	173	110963	SCREW, cap, flange head	10
118	112117	SCREW, cap, hex hd, M6	5	174	867021	NUT, hex slotted, 5/8-18	2
119	15T112	LABEL	1	175	100103	PIN, cotter	2
120▲	195793	LABEL, warning	1	176		ARTWORK, identification	1
121▲	17K396	LABEL, safety	1	177a*	17S135	CORD, power, UK	1
122▲	17Y094	LABEL, safety, prop 65	1	177b*	17R033	CORD, power, Australia	1
123	129696	SCREW, pan hd	2	177c*	17R034	CORD, power, CEE 7/7	1
124	25N604	INDICATOR, buzzer	1	177d*	17R035	CORD, power, Switzerland	1
125	17P454	CABLE, black, dia. .625 x 1 ft.	2	177e*	17R036	CORD, power, Denmark	1
126	25E392	CABLE, red, dia. .525 x 15 in.	1	177f*	17R037	CORD, power, Italy	1
127	25E393	CABLE, black, dia. .525 x 13 in.	1	178	25U747	LABEL, battery wiring	1
128	25E391	CABLE, red, dia. .525 x 10 in.	1	179	25N899	BRACKET, throttle adapter (used on early models only)	1
129	17P455	CABLE, black, dia. polarized	2	180	25N722	HARNESS, accelerator	1
130	25E389	CABLE, black, dia. .525 x 20 in.	1	181	100214	WASHER, lock	3
131	25E390	CABLE, red, dia. .525 x 20 in.	1	182	25U741	FOAM, filler	1
132	404989	STRAP, tie	1	183	25U749	FOAM, strip	1
133	25N661	HARNESS, controls	1	184†	2002461	ADAPTER, harness, controls	1
134	25N660	HARNESS, assembly	1	185	18H262	KIT, motor, <i>includes 42, 45, 62, 184</i>	1
135	25N652	CLAMP, loop	1			* Included in 25N556	
138	15R608	SPACER, duct, .50 x .75 x .062	5			† Included in 18H262	
141		SERIAL ID	2			▲ Replacement safety labels, tags, and cards are available at no cost.	
142	109032	SCREW, mach, pnh	2				
143	25N750	PAD, adhesive mounting	5				
146	25N758	BRACKET	1				
147	25N757	FILTER, LED	1				
148	25N759	COLLAR	4				
149	110963	SCREW, cap, flange hd	18				
153	126215	TRIM, edge, protection	1.5				
155	17Z070	KIT, carrier, cover	1				
156	17Z071	KIT, axle, hub	2				

Wiring Diagram - Harness 25N661

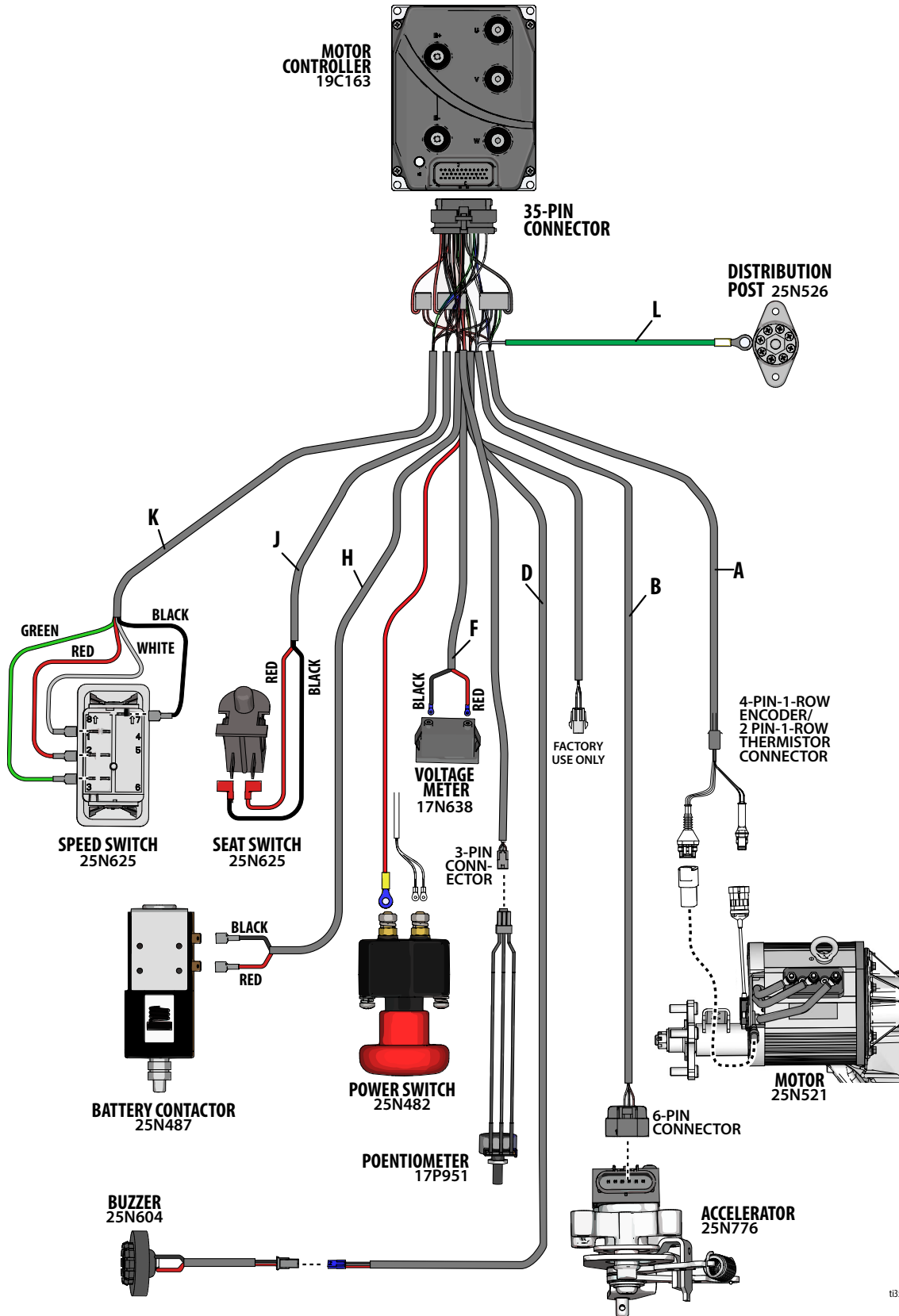

t35510b

Wiring Diagram

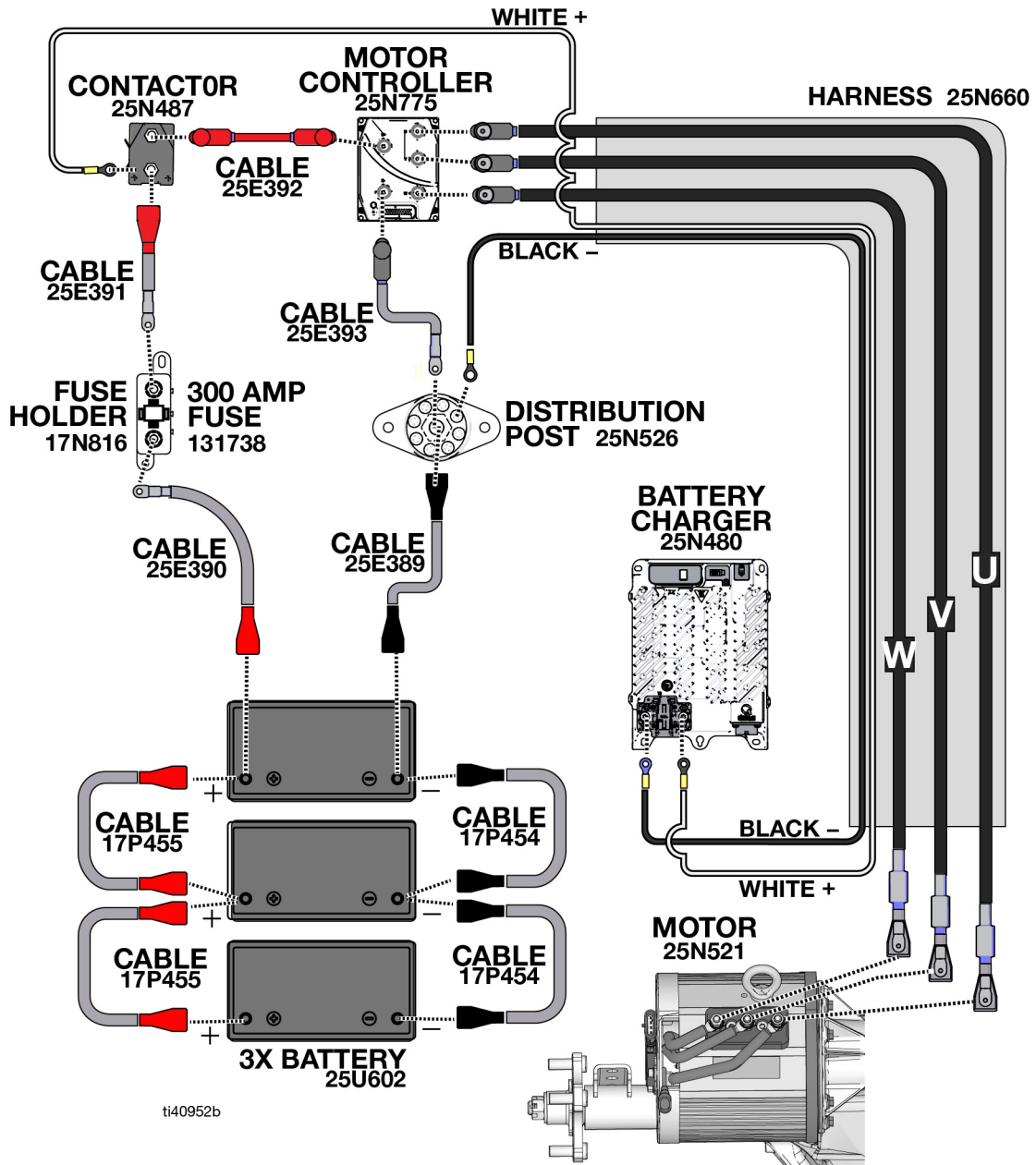

Wiring Diagram - Harness 25E406

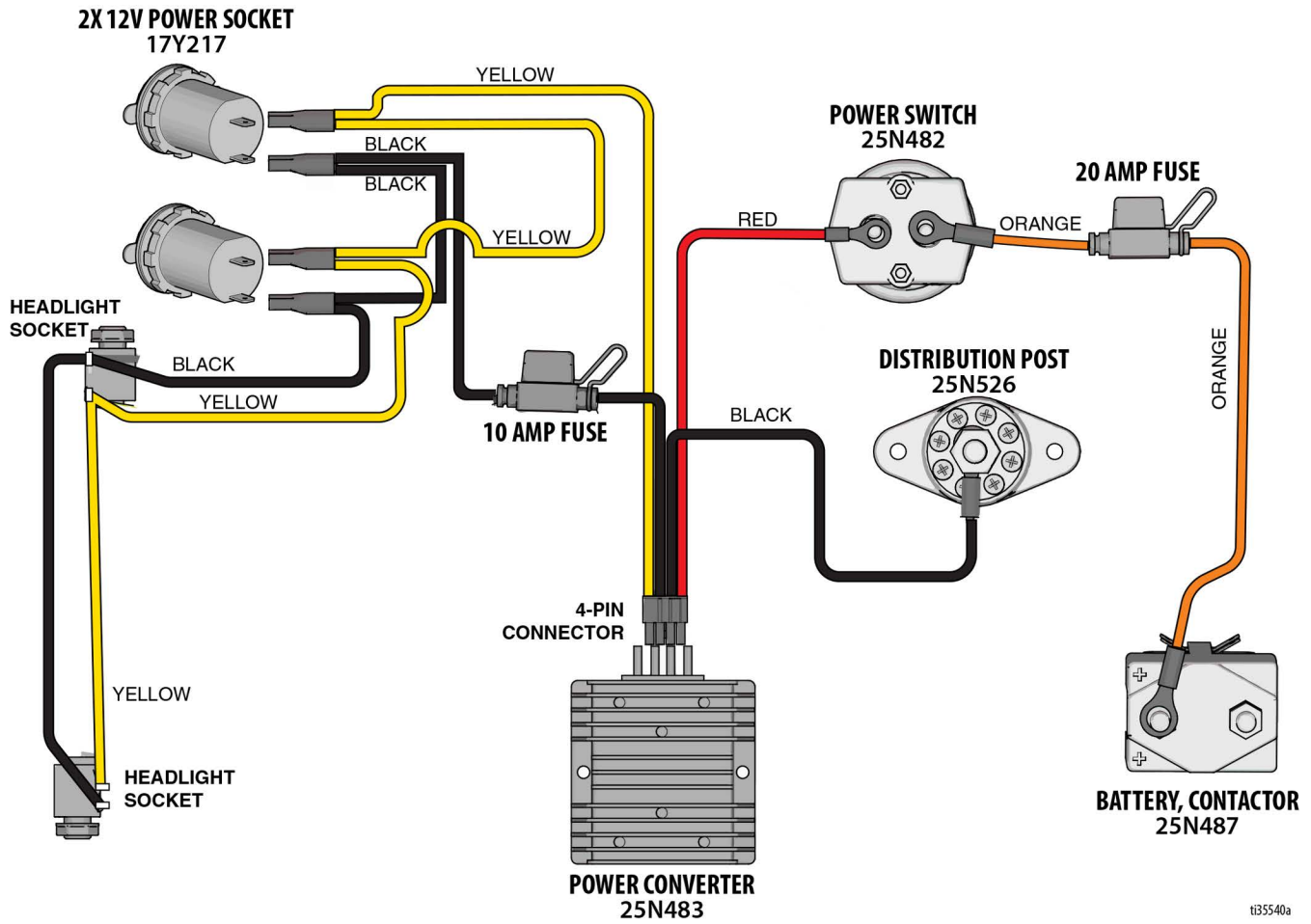

Technical Specifications

LineDriver ES Lithium		
	U.S.	Metric
Dimensions		
Height	48.5 in.	1232 mm
Width	29.3 in.	744 mm
Length	58.2 in.	1478 mm
Weight	384 lbs.	174 kg
Speed		
Forward	0-10 mph	0-16 kph
Reverse	0-6 mph	0-10 kph
Batteries		
Nominal Battery Pack Voltage	24 VDC	
Quantity	3	
Type	Lithium (LiPO4)	
Voltage (Nominal)	24 VDC	
Dimensions	12.6" x 6.93" x 8.86"	320 mm x 176 mm x 225 mm
Capacity (Nominal, 10hr rate)	50 Amp-hour / battery	
Charging Current	27.1 ADC	
Battery Charger		
Input Voltage Range	100-240 VAC	
Input Voltage Frequency	50-60 Hz	
Nominal AC input current	6.0A @ 120VAC	3.1A @ 230VAC
Max. Charger Output	650 W	
Battery Temperature		
Operating	14-140°F	-10-60°C
Charging	32-113°F	0-45°C
Storing	32-113°F	0-45°C
Noise Levels (dBa): measured at 3.1 ft (1 meter) per ISO 3744*		
Sound Power:	< 70	
Sound Pressure:	< 70	
* Does not include sound from propelled equipment - see relevant manual.		
Vibration (m/s²) (8 hours daily exposure)*		
Seat and Pedals	< 0.5	
* Does not include vibration from propelled equipment - see relevant manual.		
All trademarks or registered trademarks are the property of their respective owners.		

Technical Specifications

Storage Time	Indefinite as long as parts/components are replaced according to Storage Maintenance schedule and storage procedures specified in manual are followed.
Storage Maintenance	Change hydraulic oil and filter prior to storage.
Lifetime	Lifetime varies with use, storage methods, and maintenance. Life minimum is 25 years.
Lifetime Service Maintenance	Replace tires every 5 years or less based on use.
End of Life Disposal	If in a condition that it can no longer operate, it should be taken out of service and dismantled. Individual parts should be sorted by material and disposed of properly. Key construction materials can be found in the Materials of Construction Section.

Graco Date Code/Serial Code	Month (First Character)	Year (2nd and 3rd Characters)	Series (4th Character)	Part Number (5th-10th Characters)	Series (11th-16th Characters)
Example Date Code: A16A	A = January	16 = 2016	A = serial control number		
Example Serial Code: L16A232749000102	L = December	16 = 2016	A = serial control number	6 digit alphanumeric part number	6 digit sequential serial number

California Proposition 65

CALIFORNIA RESIDENTS

 **WARNING:** Cancer and reproductive harm – www.P65warnings.ca.gov.

Graco Standard Warranty

Graco warrants all equipment referenced in this document which is manufactured by Graco and bearing its name to be free from defects in material and workmanship on the date of sale to the original purchaser for use. With the exception of any special, extended, or limited warranty published by Graco, Graco will, for a period of twelve months from the date of sale, repair or replace any part of the equipment determined by Graco to be defective. This warranty applies only when the equipment is installed, operated and maintained in accordance with Graco's written recommendations.

This warranty does not cover, and Graco shall not be liable for general wear and tear, or any malfunction, damage or wear caused by faulty installation, misapplication, abrasion, corrosion, inadequate or improper maintenance, negligence, accident, tampering, or substitution of non-Graco component parts. Nor shall Graco be liable for malfunction, damage or wear caused by the incompatibility of Graco equipment with structures, accessories, equipment or materials not supplied by Graco, or the improper design, manufacture, installation, operation or maintenance of structures, accessories, equipment or materials not supplied by Graco.

This warranty is conditioned upon the prepaid return of the equipment claimed to be defective to an authorized Graco distributor for verification of the claimed defect. If the claimed defect is verified, Graco will repair or replace free of charge any defective parts. The equipment will be returned to the original purchaser transportation prepaid. If inspection of the equipment does not disclose any defect in material or workmanship, repairs will be made at a reasonable charge, which charges may include the costs of parts, labor, and transportation.

THIS WARRANTY IS EXCLUSIVE, AND IS IN LIEU OF ANY OTHER WARRANTIES, EXPRESS OR IMPLIED, INCLUDING BUT NOT LIMITED TO WARRANTY OF MERCHANTABILITY OR WARRANTY OF FITNESS FOR A PARTICULAR PURPOSE.

Graco's sole obligation and buyer's sole remedy for any breach of warranty shall be as set forth above. The buyer agrees that no other remedy (including, but not limited to, incidental or consequential damages for lost profits, lost sales, injury to person or property, or any other incidental or consequential loss) shall be available. Any action for breach of warranty must be brought within two (2) years of the date of sale.

GRACO MAKES NO WARRANTY, AND DISCLAIMS ALL IMPLIED WARRANTIES OF MERCHANTABILITY AND FITNESS FOR A PARTICULAR PURPOSE, IN CONNECTION WITH ACCESSORIES, EQUIPMENT, MATERIALS OR COMPONENTS SOLD BUT NOT MANUFACTURED BY GRACO. These items sold, but not manufactured by Graco (such as electric motors, switches, hose, etc.), are subject to the warranty, if any, of their manufacturer. Graco will provide purchaser with reasonable assistance in making any claim for breach of these warranties.

In no event will Graco be liable for indirect, incidental, special or consequential damages resulting from Graco supplying equipment hereunder, or the furnishing, performance, or use of any products or other goods sold hereto, whether due to a breach of contract, breach of warranty, the negligence of Graco, or otherwise.

Graco Information

For the latest information about Graco products, visit www.graco.com.

For patent information, see www.graco.com/patents.

TO PLACE AN ORDER, contact your Graco distributor or call 1-800-690-2894 to identify the nearest distributor.

*All written and visual data contained in this document reflects the latest product information available at the time of publication.
Graco reserves the right to make changes at any time without notice.*

Original instructions. This manual contains English. MM 3A9034

Graco Headquarters: Minneapolis

International Offices: Belgium, China, Japan, Korea

GRACO INC. AND SUBSIDIARIES • P.O. BOX 1441 • MINNEAPOLIS MN 55440-1441 • USA
Copyright 2021, Graco Inc. All Graco manufacturing locations are registered to ISO 9001.

www.graco.com
Revision E, November 2023