

QUANTM™ Pumps, Hygienic Models

3A9286F

EN

Electric-operated diaphragm (EODD) pumps with an integral electric drive for fluid transfer applications. For professional use only.



Important Safety Instructions

Read all warnings and instructions in this manual and related manuals before using the equipment. Save these instructions.

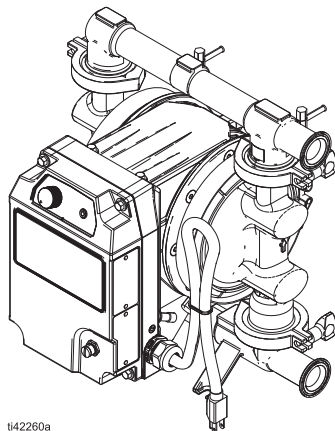

t42260a

h30 (QHC) Model

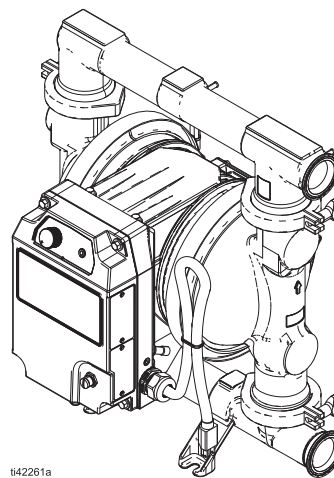

t42261a

h80 (QHD) Model

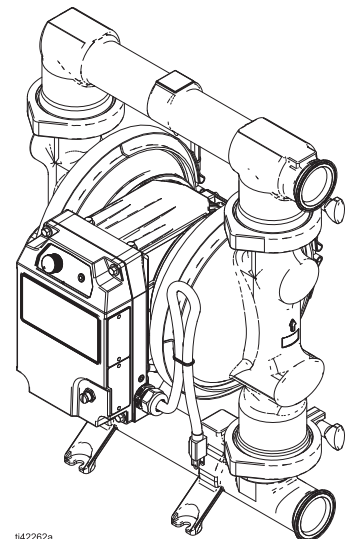

t42262a

h120 (QHE) Model

Contents

Related Manuals	3	Recycling and Disposal	45
Safety Symbols	4	Performance Charts	46
Warnings	5	Performance Chart for h30 (QHC) Models	46
Configuration Matrix	9	Performance Chart for h80 (QHD) Ball Models	47
Approvals	11	Performance Chart for h80 (QHD) Flapper Models	47
Component Identification	12	Performance Chart for h120 (QHE) Ball Models	48
Typical Installation	13	Performance Chart for h120 (QHE) Flapper Models	48
General Information	13	Dimensions	49
Typical Installation for Models in Ordinary Locations	13	Dimensions for h30 (QHC) Models	49
Typical Installation for Models in Explosive Atmospheres or Hazardous (Classified) Locations	14	Dimensions for h80 (QHD) Models	52
Installation	15	Dimensions for h120 (QHE) Ball Models	55
Mount the Pump	15	Dimensions for h120 (QHF) Flapper Models	58
Connect Fluid Lines	15	Technical Specifications	60
Install Accessories	16	Fluid Temperature Range	60
Grounding	17	Technical Specifications for h30 (QHC) Models	62
Before First Use	18	Technical Specifications for h80 (QHD) Ball Models	63
Electrical Connections and Wiring	19	Technical Specifications for h80 (QHD) Flapper Models	64
Required Power and Plugs	19	Technical Specifications for h120 (QHE) Ball Models	65
Wire Power Cables	20	Technical Specifications for h120 (QHE) Flapper Models	66
Requirements for Cables and Conduits	21	California Proposition 65	67
Adapters for Plugs and Cables	21	Graco Standard Warranty	68
I/O Pin Connection	22		
Operation	25		
Pressure Relief Procedure	25		
Before Each Use	25		
Start the Equipment	25		
Shut Down the Equipment	27		
LED Indicator	28		
LED Indicator Overview	28		
LED Indicator Event Errors	29		
Maintenance	31		
Lubricate the Equipment	31		
Flush the Equipment	31		
Store the Equipment	32		
Clean the Wetted Section	32		
Troubleshooting	33		
Repair	36		
Prepare Equipment for Repair	36		
Repair the Check Valves (Ball Pumps)	37		
Repair the Check Valves (Flapper Pumps)	38		
Repair the Standard Diaphragms	40		
Repair the Overmolded Diaphragms	43		







Related Manuals

English Manual Number	Description	Reference
3A7637	QUANTM Electric Motor, Repair-Parts	Motor Manual
3A9287	QUANTM Pumps, Hygienic Models, Parts	Parts Manual
3A8861	QUANTM Leak Sensor, Instruction	Kit Instructions
3A8982	QUANTM I/O Cable Kit (Hazardous Locations)	Kit Instructions

Safety Symbols







The following safety symbols appear throughout this manual and on warning labels. Read the table below to understand what each symbol means.

Symbol	Meaning
	Burn Hazard
	Cleaning Solvent Hazard
	Electric Shock Hazard
	Equipment Misuse Hazard
	Fire and Explosion Hazard
	Entanglement Hazard
	Moving Parts Hazard
	Pressurized Equipment Hazard
	Splash Hazard
	Toxic Fluid or Fumes Hazard

Symbol	Meaning
	Ground Equipment
	Read Manual
	Follow Pressure Relief Procedure
	Ventilate Work Area
	Wear Personal Protective Equipment
	Do Not Wipe with a Dry Cloth
	Eliminate Ignition Sources

Warnings

The following warnings are for the setup, use, grounding, maintenance, and repair of this equipment. The exclamation point symbol alerts you to a general warning and the hazard symbols refer to procedure-specific risks. When these symbols appear in the body of this manual or on warning labels, refer back to these Warnings. Product-specific hazard symbols and warnings not covered in this section may appear throughout the body of this manual where applicable.

 <h2 style="margin: 0;">WARNING</h2>	
    	<p>FIRE AND EXPLOSION HAZARD</p> <p>Flammable fumes, such as solvent and paint fumes, in work area can ignite or explode. Paint or solvent flowing through the equipment can cause static sparking. To help prevent fire and explosion:</p> <ul style="list-style-type: none"> • Use equipment only in well-ventilated area. • Eliminate all ignition sources; such as pilot lights, cigarettes, portable electric lamps, and plastic drop cloths (potential static sparking). • Ground all equipment in the work area. See Grounding instructions. • Keep work area free of debris, including solvent, rags and gasoline. • Do not plug or unplug power cords, or turn power or light switches on or off when flammable fumes are present. • Use only conductive grounded fluid lines. • Stop operation immediately if static sparking occurs or you feel a shock. Do not use equipment until you identify and correct the problem. • Keep a working fire extinguisher in the work area. <p>Static charge may build up on plastic parts during cleaning and could discharge and ignite flammable vapors. To help prevent fire and explosion:</p> <ul style="list-style-type: none"> • Clean plastic parts only in well-ventilated area. • Do not clean with a dry cloth.



WARNING



ELECTRIC SHOCK HAZARD

Explosive Atmospheres or Hazardous (Classified) Locations Models (hard wired for permanent connection)

This equipment must be grounded. Improper grounding, setup, or usage of the system can cause electric shock.

- Turn off and disconnect power at main switch before disconnecting any cables and before servicing or installing equipment.
- Connect only to grounded power source.
- All electrical wiring and repairs must be done by a qualified electrician and comply with all local codes and regulations.
- Store indoors.

Ordinary Locations Models (cord and plug connection)

This equipment must be grounded. Improper grounding, setup, or usage of the system can cause electric shock.

- Turn off and disconnect power cord before servicing equipment.
- Connect only to grounded electrical outlets.
- Only use 3-wire extension cords for 2-phase models. Only use 4-wire extension cords for 3-phase models.
- Ensure ground prongs are intact on power and extension cords.
- Store indoors.
- Wait five minutes after disconnecting power cord before servicing.



















EQUIPMENT MISUSE HAZARD

Misuse can cause death or serious injury.

- Do not operate the unit when fatigued or under the influence of drugs or alcohol.
- Do not exceed the maximum working pressure or temperature rating of the lowest rated system component. See **Technical Specifications** in all equipment manuals.
- Use fluids and solvents that are compatible with equipment wetted parts. See **Technical Specifications** in all equipment manuals. Read fluid and solvent manufacturer's warnings. For complete information about your material, request Safety Data Sheets (SDSs) from distributor or retailer.
- Turn off all equipment and follow the **Pressure Relief Procedure** when equipment is not in use.
- Check equipment daily. Repair or replace worn or damaged parts immediately with genuine manufacturer's replacement parts only.
- Do not alter or modify equipment. Alterations or modifications may void agency approvals and create safety hazards.
- Make sure all equipment is rated and approved for the environment in which you are using it.
- Use equipment only for its intended purpose. Call your distributor for information.
- Route fluid lines, cords, and cables away from traffic areas, sharp edges, moving parts, and hot surfaces.
- Do not kink or over-bend fluid lines, cords, or cables. Do not use fluid lines, cords, or cables to pull equipment.
- Keep children and animals away from work area.
- Comply with all applicable safety regulations.



 <h1 style="margin: 0;">WARNING</h1>	
 	<p>PLASTIC PARTS CLEANING SOLVENT HAZARD</p> <p>Many cleaning solvents can degrade plastic parts and cause them to fail, which could cause serious injury or property damage.</p> <ul style="list-style-type: none"> • Use only compatible solvents to clean plastic structural or pressure-containing parts. • See Technical Specifications in all equipment manuals for materials of construction. Consult the solvent manufacturer for information and recommendations about compatibility.
  	<p>PRESSURIZED EQUIPMENT HAZARD</p> <p>Fluid from the equipment, leaks, or ruptured components can splash in the eyes or on skin and cause serious injury.</p> <ul style="list-style-type: none"> • Follow the Pressure Relief Procedure when you stop spraying/dispensing and before cleaning, checking, or servicing equipment. • Tighten all fluid connections before operating the equipment. • Check fluid lines and connections daily. Replace worn or damaged parts immediately.
	<p>PRESSURIZED ALUMINUM PARTS HAZARD</p> <p>Use of fluids that are incompatible with aluminum in pressurized equipment can cause serious chemical reaction and equipment rupture. Failure to follow this warning can result in death, serious injury, or property damage.</p> <ul style="list-style-type: none"> • Do not use 1,1,1-trichloroethane, methylene chloride, other halogenated hydrocarbon solvents or fluids containing such solvents. • Do not use chlorine bleach. • Many other fluids may contain chemicals that can react with aluminum. Contact your material supplier for compatibility.
  	<p>THERMAL EXPANSION HAZARD</p> <p>Fluids subjected to heat in confined spaces, including fluid lines, can create a rapid rise in pressure due to the thermal expansion. Over-pressurization can result in equipment rupture and serious injury.</p> <ul style="list-style-type: none"> • Open a valve to relieve the fluid expansion during heating. • Replace fluid lines proactively at regular intervals based on your operating conditions.
	<p>TOXIC FLUID OR FUMES HAZARD</p> <p>Toxic fluids or fumes can cause serious injury or death if splashed in the eyes or on skin, inhaled, or swallowed.</p> <ul style="list-style-type: none"> • Read Safety Data Sheets (SDSs) to know the specific hazards of the fluids you are using. • Store hazardous fluid in approved containers, and dispose of it according to applicable guidelines.

 <h1 style="margin: 0;">WARNING</h1>	
	<p>BURN HAZARD</p> <p>Equipment surfaces and fluid that is heated can become very hot during operation. To avoid severe burns:</p> <ul style="list-style-type: none"> • Do not touch hot fluid or equipment.
	<p>PERSONAL PROTECTIVE EQUIPMENT</p> <p>Wear appropriate protective equipment when in the work area to help prevent serious injury, including eye injury, hearing loss, inhalation of toxic fumes, and burns. Protective equipment includes but is not limited to:</p> <ul style="list-style-type: none"> • Protective eyewear, and hearing protection. • Respirators, protective clothing, and gloves as recommended by the fluid and solvent manufacturer.
 	<p>MOVING PARTS HAZARD</p> <p>Moving parts can pinch, cut or amputate fingers and other body parts.</p> <ul style="list-style-type: none"> • Keep clear of moving parts. • Do not operate equipment with protective guards or covers removed. • Equipment can start without warning. Before checking, moving, or servicing equipment, follow the Pressure Relief Procedure and disconnect all power sources.

Configuration Matrix

Record the model part number and configuration sequence found on your equipment identification plate (ID) to assist you when ordering replacement parts.

Model Part Number:

Configuration Sequence:

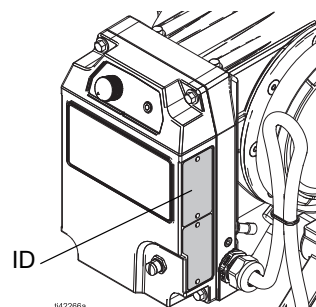

Sample Configuration Sequence: QHC-FGFF1ACACBNBNA10021											
Q	H	C	FG	FF1	AC	AC	BN	BN	A1	00	21
Brand	Application	Model	Wetted Section Material	Motor	Seat Material	Check Material	Diaphragm Material	Manifold Seal Material	Connection	Options	Material Certifications

NOTE: Some combinations are not possible. Check with your local distributor.

Brand		Application		Model		Wetted Section Material	
Q	QUANTM	H	Hygienic (h)	C	30 (1 in. port)	FG	Food Grade, Stainless Steel, 125 micro finish (cast CF8M)
				D	80 (1-1/2 in. port)	HS	Hygienic, Stainless Steel, 32 micro finish
				E	120 (2 in. port)	PH	Pharmaceutical, Stainless Steel, 20 micro finish
				F	120 (3 in. port)	3A	3-A Hygienic, Stainless Steel, 32 micro finish

Motor						
	Drive	Coat	Input Voltage	Phase	Location	Cord/Cable Termination
FF1	Aluminum Direct Drive	Fluorinated ethylene propylene (FEP) coat	200–240 V	3-Phase	Hygienic, Ordinary Locations	Cord with plug
FF2	Aluminum Direct Drive	FEP coat	200–240 V	Single-Phase	Hygienic, Ordinary Locations	Cord with plug
FF3	Aluminum Direct Drive	FEP coat	200–240 V	3-Phase	Hygienic, Hazardous (Classified) Locations	Cable with flying leads
FF4	Aluminum Direct Drive	FEP coat	200–240 V	Single-Phase	Hygienic, Explosive Atmospheres	Cable with flying leads
FF5	Aluminum Direct Drive	FEP coat	100–120 V	Single-Phase	Hygienic, Ordinary Locations	Cord with plug
FF6	Aluminum Direct Drive	FEP coat	100–120 V	Single-Phase	Hygienic, Hazardous (Classified) Locations	Cable with flying leads





Configuration Matrix

Seat Material		Check Material		Diaphragm Material		Manifold Seal Material	
FL	Flapper, for hygienic models only	BN	Buna-N, ball	BN	Buna-N	--	None
SS	316 Stainless Steel	CW	Polychloroprene, weighted, ball	EO	EPDM Overmold	BN	Buna-N
		EP	EPDM, ball	FK	Fluoroelastomer	EP	EPDM
		FK	Fluoroelastomer, ball	PO	PTFE/EPDM Overmold	FK	Fluoroelastomer
		FL	Flapper, Stainless Steel	PS	PTFE/Santoprene, two-piece	PT	PTFE
		PT	PTFE, ball	SP	Santoprene		
		SP	Santoprene, ball				

Connection		Options		Material Certifications	
S13	Stainless Steel, standard ports, hygienic clamp	00	Standard	21	EN 10204 type 2.1
S14	Stainless Steel, standard ports, DIN	SF	Sanitary Flapper	31	EN 10204 type 3.1
SSA	Center-ported tri-clamp				
SSB	Center-ported DIN				
SSE	Horizontal Wye Manifold Tri-Clamp				
SSG	Horizontal No Manifold				

Motor Drive Selection			
Hygienic - North America			
Model	Ordinary Location (NEMA Plug)	Hazardous Location (Flying Leads)	Voltage range/phase count
h30 (QHC)	FF1, FF5	FF3, FF6	200/240V/3-Phase 100/120V/Single-Phase
h80 (QHD)	FF1	FF3	200/240V/3-Phase
h120 (QHE)/(QHF)	FF1	FF3	200/240V/3-Phase
Hygienic - International			
Model	Ordinary Location (IEC Plug)	Hazardous Location (Flying Leads)	Voltage range/phase count
h30 (QHC)	FF2	FF4	200/240V/Single-Phase
h80 (QHD)	FF2	FF4	200/240V/Single-Phase
h120 (QHE)/(QHF)	FF2	FF4	200/240V/Single-Phase

Approvals

Model Information*	Approvals
Motors	For motor approvals, see your related motor manual. See Related Manuals , page 3.
Pump models with motor code FF2	
Pump models with motor code FF4	  II 2 G Ex db h IIB T4 Gb NOTE: Type of Protection “h” applied is constructional safety “c.”
Hygienic (QH) models with diaphragm materials coded EO, PO, or PS combined with EP, PT, or FL checks comply with:	 EC 1935/2004  Class VI
Wetted contact section materials in Hygienic (QH) models are FDA-compliant and meet the United States Code of Federal Regulations (CFR).	

* See **Configuration Matrix**, starting on page 9, for detailed descriptions.

Component Identification

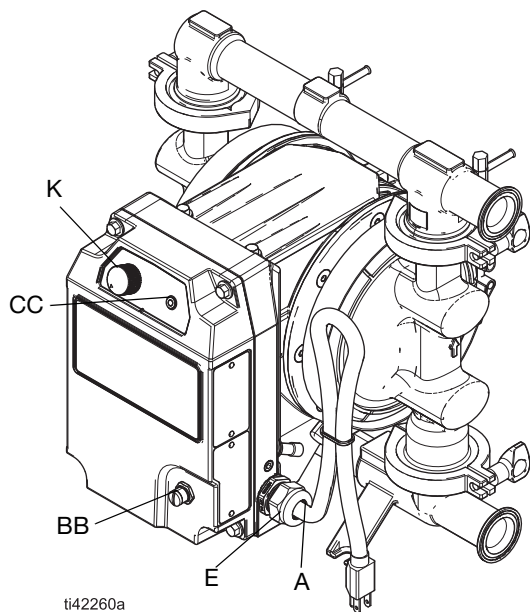

FIG. 1: Ordinary Locations Model (h30 (QHC) model shown)

Ordinary Locations models include a cord with a plug and Input/Output (I/O) port.

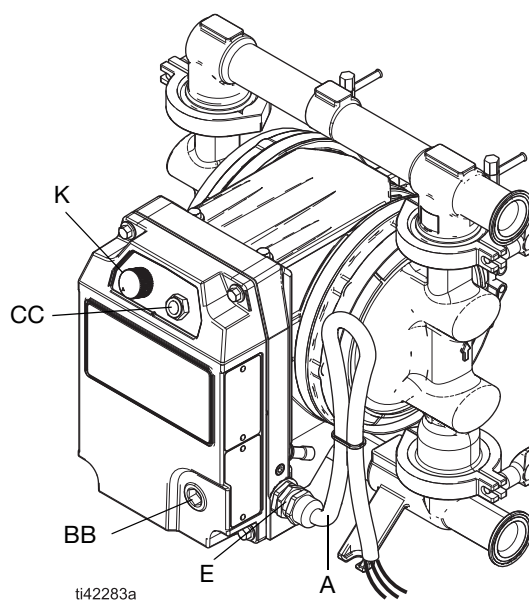



FIG. 2: Explosive Atmospheres or Hazardous (Classified) Locations Model (h30 (QHC) model shown)

Explosive Atmospheres or Hazardous (Classified) Locations models include flying leads on the power cable (for direct wiring to a power source).

Ref.	Component	Ordinary Locations Models	Explosive Atmospheres or Hazardous (Classified) Locations Models
A	Power Cord/Cable	15 ft (4.6 m) cord with plug*	15 ft (4.6 m) cable for hard-wiring†
BB	I/O Port/Cable On/Off Control, Digital Input Run Status, Digital Output Speed and Pressure Control, Analog Input	M12, 5-pin connector**	Cable (not supplied) for direct wiring to user-provided controls‡
CC	LED Indicator♦	Standard	Reinforced
E	External Ground Fastener, Ground Symbol	The equipment is marked per IEC 417, Symbol 5019: 	
K	Control Knob	Turn clockwise (right) to increase fluid output	

* See **Required Power and Plugs**, page 19.

** See **I/O Pin Connection**, page 22.

† See **Wire Power Cables**, page 20, and **Requirements for Cables and Conduits**, page 21.

‡ I/O cable kits are available (purchase separately). See **Related Manuals**, page 3.

♦ See **LED Indicator**, page 28.

Typical Installation

General Information

Typical installations are shown in FIG. 3 and FIG. 4. The figures are only guides for selecting and installing system components. Contact your local distributor for assistance in planning a system to suit your needs.

Always use Genuine Graco Parts and accessories. Be sure all accessories are adequately sized and pressure-rated to meet the requirements of the system.

Reference letters in the text, for example, (A), refer to the callouts in the figures.

Typical Installation for Models in Ordinary Locations

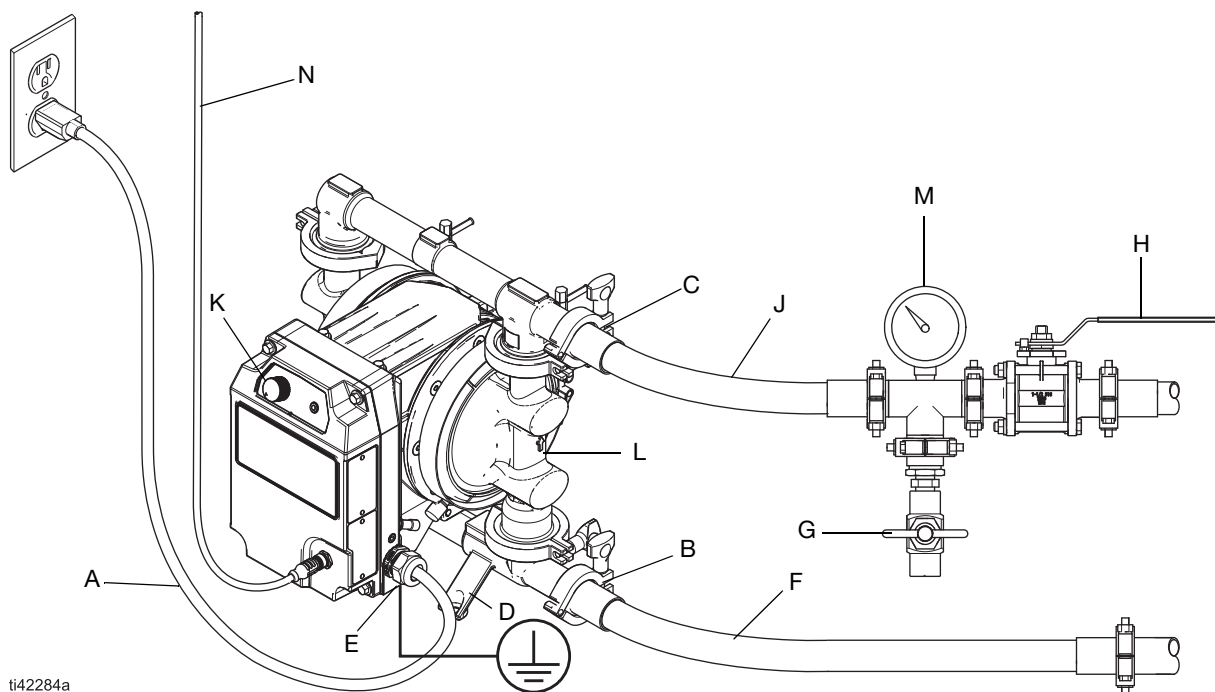

ti42284a

FIG. 3: Typical Installation for Models in Ordinary Locations (cord and plug connection) (h30 (QHC) model shown)

Pump Components

- A** ♦ Power cord
- B** Fluid inlet port
- C** Fluid outlet port
- D** Mounting feet
- E** Ground fastener
- K** Fluid output control knob
- L** ▼ Diaphragm access ports (not shown)

♦ Connect to a circuit with a main electrical disconnect. Install a branch circuit protective device in each ungrounded phase. Follow local codes and regulations.

▼ See *Install Leak Sensor Hoses and Fittings*, page 16, or *Install Fluid Leak Line Accessories*, page 16.

Accessories (Not Supplied)

- F*** Conductive, flexible fluid supply line
- G*** Fluid drain valve
- H** Fluid shutoff valve
- J*** Conductive, flexible fluid outlet line
- M** Fluid pressure gauge
- N** I/O Cable

* Required, not supplied.

Typical Installation for Models in Explosive Atmospheres or Hazardous (Classified) Locations

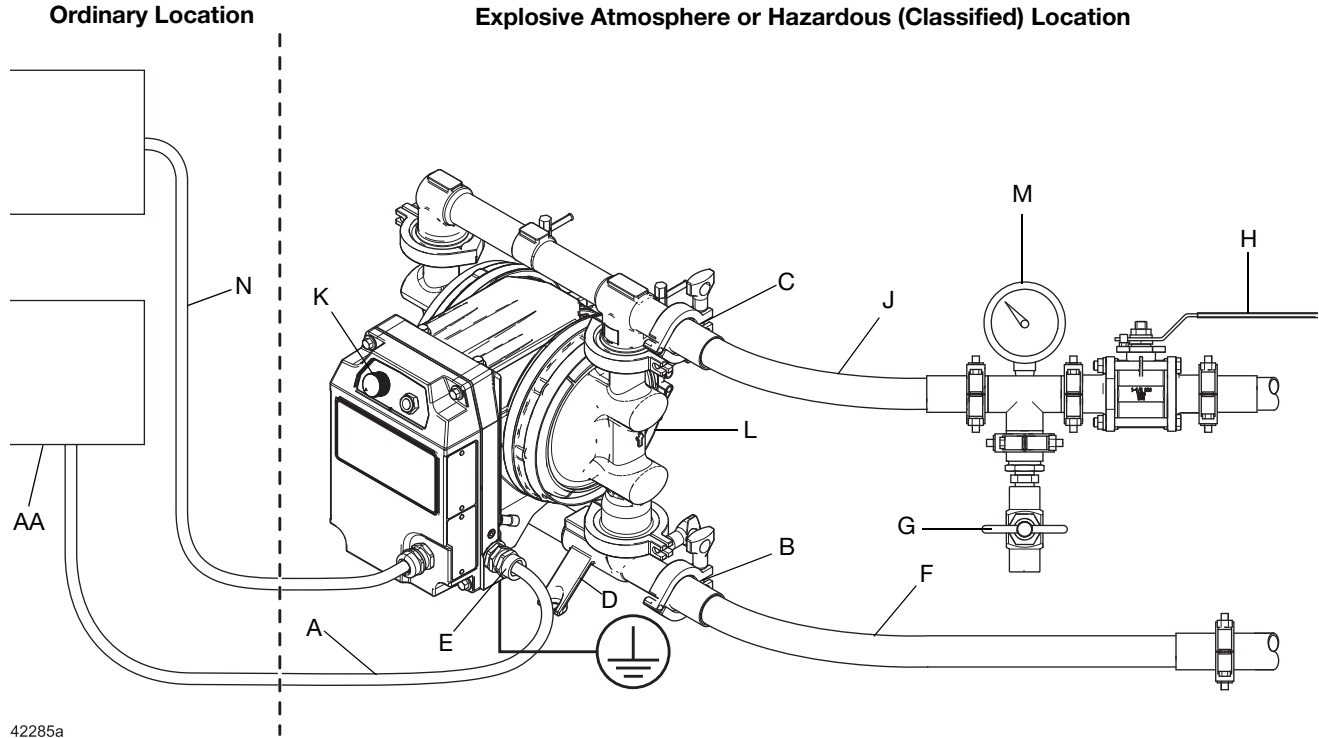

FIG. 4: Typical Installation for Models in Explosive Atmospheres or Hazardous (Classified) Locations (hard wired for permanent connection) (h30 (QHC) model shown)

Pump Components	Accessories (Not Supplied)
A ♦ Power cable	F* Conductive, flexible fluid supply line
B Fluid inlet port	G* Fluid drain valve
C Fluid outlet port	H Fluid shutoff valve
D Mounting feet	J* Conductive, flexible fluid outlet line
E Ground fastener	M Fluid pressure gauge
K Fluid output control knob	N*‡ I/O Cable
L ▼ Diaphragm access ports (not shown). Diaphragm access ports must not be open in hazardous locations. Ports must have installed either plugs 128658 (as shipped from the factory), or leak sensor kit 25F109.	AA Electrical disconnect

♦ Connect to a circuit with a main electrical disconnect. Install a branch circuit protective device in each ungrounded phase. Follow local codes and regulations.

▼ See **Install Leak Sensor Hoses and Fittings**, page 16, or **Install Fluid Leak Line Accessories**, page 16.

* Required, not supplied.

‡ I/O cable kits are available (purchase separately). See **Related Manuals**, page 3.

Installation

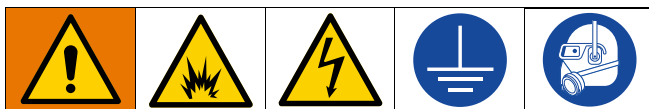

Installation of this equipment involves potentially hazardous procedures. Only trained and qualified personnel who have read and who understand the information in this manual should install this equipment.

To avoid injury from fire, explosion, or electric shock, all electrical wiring must be done by a qualified electrician and comply with all local codes and regulations.

Mount the Pump



The pump may be very heavy (see **Technical Specifications**, starting on page 60, for specific weights). Use at least two straps to evenly support the bottom of the pump, and appropriate lifting equipment or have two people lift the pump. Do not use the upper manifold or port (C) alone to lift the pump.

Mount the pump to the mounting surface using fasteners through each hole of the feet. See FIG. 5.

1. Ensure that the mounting surface is level.
2. Ensure that the mounting surface and mounting hardware is strong enough to support the weight of the pump, fluid lines, accessories, and fluid, as well as the stress caused during operation.
3. For all mountings, be sure the pump is secured with fasteners through the mounting holes on the base. See FIG. 5. See **Dimensions**, starting on page 49.

NOTE: For ease of operation and service, mount the pump so the control knob (K), LED indicator (CC), I/O port/cable (BB), and fluid inlet and outlet ports (B, C) are easily accessible.

NOTICE

To avoid pump damage, mount the pump to the mounting surface using fasteners through each hole of the feet. See FIG. 5.

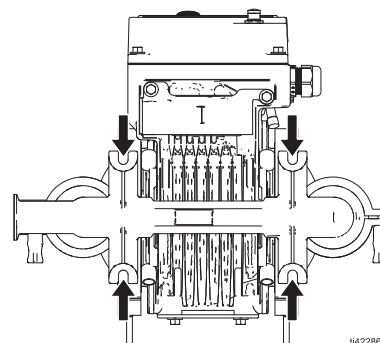

FIG. 5: Mounting Holes

Connect Fluid Lines

Use conductive, flexible fluid lines for fluid supply (F) and fluid outlet (J) lines.

NOTE: For proper priming, ensure the fluid outlet port (C) is mounted higher than the fluid inlet port (B). See FIG. 3 and FIG. 4.

1. Install conductive, flexible fluid lines (F and J).
2. Install a fluid drain valve (G) near the fluid outlet. See FIG. 3 and FIG. 4.



A fluid drain valve (G) is required to relieve pressure in the fluid outlet line. The drain valve reduces the risk of serious injury, including splashing in the eyes or on the skin, when relieving pressure.

3. Install a fluid shutoff valve (H) in the fluid outlet line (J) downstream from the fluid drain valve (G).

NOTE: Install the equipment as close as possible to the material source. See **Technical Specifications**, starting on page 60, for maximum suction lift.

NOTICE

The pump can be damaged if flexible fluid lines are not used. If hard-plumbed fluid lines are used in the system, use a short length of conductive, flexible fluid line to connect to the pump.

Install Accessories

Install Leak Sensor Hoses and Fittings

The leak sensor monitors for leaks in the pump due to diaphragm rupture or other leaks in the equipment. If the sensor detects a leak, the LED indicator on the pump will flash and the pump will stop.

The leak sensor is installed in certain models at the factory or by the distributor. A leak sensor kit is available for initial installation or replacement. See the electric motor manual for Accessory Kits. See **Related Manuals**, page 3.

For models with a factory-installed leak sensor, you must install the external hoses and fittings before using the pump for the first time. See the Leak Sensor Instructions manual for instructions. See **Related Manuals**, page 3.

NOTICE

To avoid pump damage, install a leak sensor to detect leaks in the equipment due to diaphragm rupture.

Install Fluid Line Accessories

Install the following accessories in the order shown in FIG. 3 and FIG. 4, using adapters as needed.

- **Fluid drain valve (G):** Required. Relieves fluid pressure in the system.
- **Fluid shutoff valve (H):** Shuts off fluid flow.
- **Fluid pressure gauge (M):** For more precise adjustment of the fluid pressure.
- **Fluid outlet line (J):** Required. To dispense fluid.
- **Fluid supply line (F):** Required. Enables the equipment to draw fluid from a container.

Install Fluid Leak Line Accessories



If a leak sensor is not installed in the pump and the diaphragm ruptures, the equipment will fill with fluid or fluid will drain into the work area. To avoid injury from leaking fluid, toxic fluid, toxic fumes, splashing fluid, or hot fluid, install fluid drain lines to route fluid leaks due to diaphragm rupture.

NOTICE

To avoid pump damage due to diaphragm rupture, install a leak sensor to detect leaks in the equipment and automatically stop pump operation. See **Install Leak Sensor Hoses and Fittings**, page 16.

The fluid leak line (L2) routes fluid to a drain location if fluid leaks due to diaphragm rupture.

1. Remove the plugs (if applicable) in the diaphragm access ports (L).
2. Install conductive, flexible fluid leak lines (L2) to the diaphragm access ports (L). Use adapters as needed.
3. Route the fluid leak lines (L2) to a grounded end container (L3) to catch leaking fluid. Follow local codes and regulations for grounding.



For Models in Explosive Atmospheres or Hazardous (Classified) Locations) without a leak sensor: To avoid injury from hazardous fluids, ensure that the end container is grounded and located in a non-explosive or non-hazardous environment. Diaphragm access ports must not be open in hazardous locations. Ports must have installed either plugs 128658 (as shipped from the factory), or leak sensor kit 25F109.

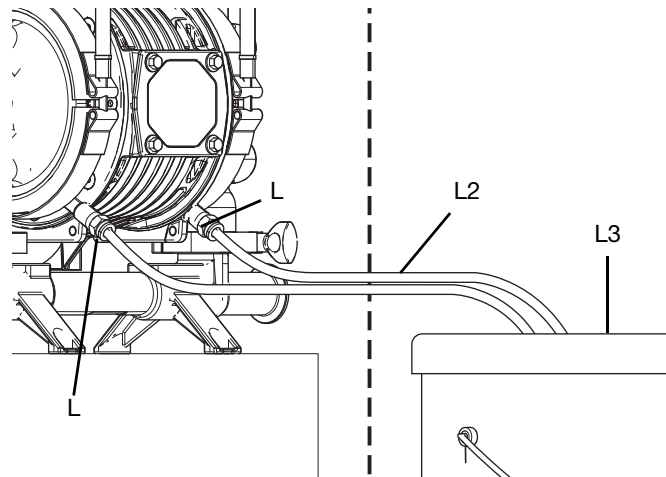





Fig. 6: Typical Installation of Fluid Leak Lines (Ordinary Locations)

Grounding

				
<p>The equipment must be grounded to reduce the risk of static sparking and electric shock. Electric or static sparking can cause fumes to ignite or explode. Improper grounding can cause electric shock. Grounding provides an escape wire for the electric current.</p> <ul style="list-style-type: none"> • Always ground the entire fluid system as described in this section. • Follow local codes and regulations. 				

Before operating the equipment, ground the system as follows.

Ground the Pump

Connect a Static Ground

See FIG. 7.

1. Loosen the ground fastener (E).
2. Insert one end of a 12-gauge or thicker ground wire behind the ground fastener and securely tighten the ground fastener (E).
3. Connect the clamp end of the ground wire to a true earth ground.

NOTE: A ground wire and clamp (part number 238909) is available (purchase separately).

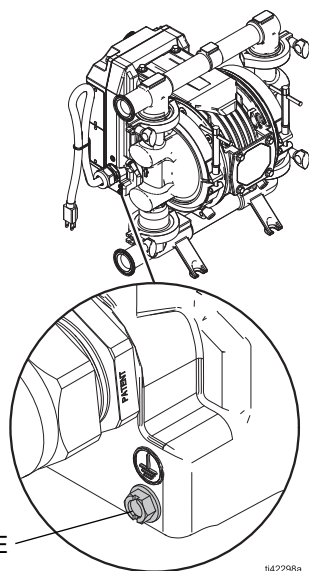

FIG. 7: Equipment Ground Fastener

Connect the Electrical Ground

For Models in Explosive Atmospheres or Hazardous (Classified) Locations: Ground through the ground wire of the power cable to a true earth ground. Connect the ground wire of the power cable to a true earth ground. See **Electrical Connections and Wiring**, starting on page 19.

For Models in Ordinary Locations: Ground through the provided power cord and plug. Connect the plug to a power outlet that is properly installed and grounded to a true earth ground.

Ground the Fluid Lines

Use only conductive fluid lines with a maximum of 500 ft (150 m) combined line length to ensure grounding continuity. Check electrical resistance of the fluid lines.

Ground the Fluid Supply Container

Follow local codes and regulations.

Ground the Pails for Solvents and compatible sanitizing solution Used when Flushing

Follow local codes and regulations. Use only conductive metal pails, placed on a grounded surface. Do not place the pail on a non-conductive surface, such as paper or cardboard, which interrupts grounding continuity.

Verify Ground Continuity

Check the pump ground continuity after the initial installation. Set a regular schedule for checking ground continuity to maintain proper grounding. Do not exceed 1 ohm resistance from earth ground to the pump.

Before First Use

Tighten Fasteners

Before using the equipment for the first time, check and tighten all fasteners.

After the first day of operation, re-tighten the fasteners.

NOTICE

To avoid pump damage, do not over-tighten the fasteners on the equipment.

Tighten Connections

Check and tighten all fluid connections before operating the equipment. Replace worn or damaged parts as needed.

NOTICE

Firmly tighten all connections to avoid leaks and damage to equipment parts.



Flush the Equipment

Before using the equipment for the first time, flush the equipment. Follow **Flush the Equipment**, page 31.

The equipment was tested using a food grade lubricant. If a food grade lubricant could contaminate the fluid being dispensed, flush the equipment thoroughly with a compatible sanitizing solution before first use.





Electrical Connections and Wiring

Required Power and Plugs

				
To avoid injury from fire, explosion, or electric shock, all electrical wiring must be done by a qualified electrician and comply with all local codes and regulations.				

NOTE: For equipment provided with a cable and flying leads (no plug), install a main electrical disconnect per local codes and regulations.

NOTE: Use adapters as needed. Follow local codes and regulations.

Required Power and Plugs								
Location	Motor Configuration Code*	Model	Power Requirements				Cord/Cable Termination	Plug
			Input Voltage	Phase [‡]	Hertz	Current		
Ordinary Locations	FF1	h30 (QUC), h80 (QHD), h120 (QHE)	200–240 V	3	50/60 Hz	7.5 A	NEMA L15-20 Plug	
	FF2	h30 (QHC)	200–240 V	1	50/60 Hz	10 A	IEC 60320-C14 Plug [♦]	
		h80 (QHD), h120 (QHE)	200–240 V	1	50/60 Hz	15 A	IEC 60320-C20 Plug [♦]	
	FF5	h30 (QHC)	100–120 V	1	50/60 Hz	12 A	NEMA 5-15 Plug	
Hazardous (Classified) Locations	FF3	h30 (QHC), h80 (QHD), h120 (QHE)	200–240 V	3	50/60 Hz	7.5 A	Flying Leads, see FIG. 10	For permanent connection [■]
	FF6	h30 (QHC)	100–120 V	1	50/60 Hz	12 A	Flying Leads, see FIG. 9	
Explosive Atmospheres	FF4	h30 (QHC)	200–240 V	1	50/60 Hz	10 A	Flying Leads, see FIG. 9	
		h80 (QHD), h120 (QHE)	200–240 V	1	50/60 Hz	15 A		

* See **Configuration Matrix**, starting on page 9, for detailed descriptions.

[‡] Connect to a circuit with a main electrical disconnect. Install a branch circuit protective device in each ungrounded phase. Follow local codes and regulations.

[■] See **Wire Power Cables**, page 20.

[♦] Adapters are available (purchase separately). See **Adapters for Plugs and Cables**, page 21.

Wire Power Cables



For models in Explosive Atmospheres or Hazardous (Classified) Locations only.

To connect an Explosive Atmospheres or Hazardous (Classified) Locations model to a power source, complete one of the following:

- Hard wire the equipment to a power source.
- Supply a plug, socket, and interlocking device that meets the requirements of EN 60079-0 or UL 674.

NOTE: See **Required Power and Plugs**, page 19, for power requirements. Install a branch circuit protective device in each ungrounded phase.

A 15 ft (4.6 m) cable (either 3-conductor or 4-conductor) is provided with models for Explosive Atmospheres or Hazardous (Classified) Locations. Connect the cable directly to a panel with branch circuit protection and an electrical disconnect per local codes and regulations. If additional length of cable is required, connect additional cable through a junction box. Use the following table to select the minimum cable wire gauge based on length:

Length	Gauge	mm ²
50 ft (15.2 m)	12 AWG	3.3
100 ft (30.4 m)	10 AWG	5.3
200 ft (61 m)	8 AWG	13.3

NOTE: Ensure that the electrical disconnect (AA) is shut off and locked out before wiring. See FIG. 8.

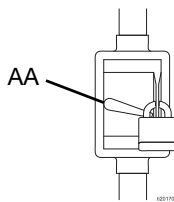
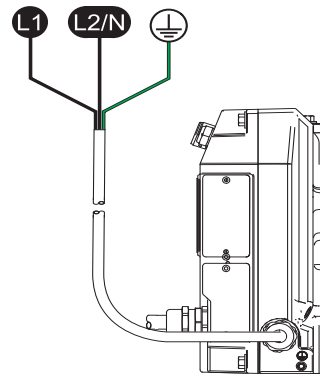

FIG. 8: Electrical Disconnect

Wire Single-Phase Models

For models in Explosive Atmospheres or Hazardous (Classified) Locations only. See FIG. 9.

1. **FF6 motors:** Connect the black wire to Line 1 (L1, black).
FF4 motors: Connect the brown wire to Line 1 (L1, brown).
2. **FF6 motors:** Connect the white wire to Neutral (L2/N, white).
FF4 motors: Connect the blue wire to Line 2 (L2/N, blue).
3. Connect the ground wire (green) to a true earth ground.



ti39015a

FIG. 9: Wiring for Single-Phase Models

Wire 3-Phase Models

For models in Explosive Atmospheres or Hazardous (Classified) Locations only. See FIG. 10.

1. Connect the black wire to Line 1 (black, L1).
2. Connect the white wire to Line 2 (white, L2).
3. Connect the red wire to Line 3 (red, L3).
4. Connect the ground wire (green) to a true earth ground.

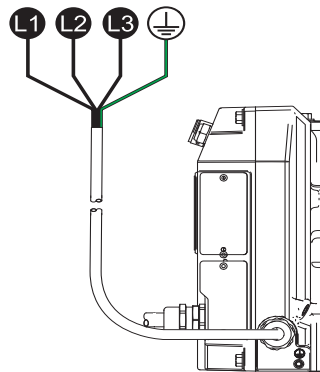

ti40182a

FIG. 10: Wiring for 3-Phase Models

Requirements for Cables and Conduits

For models in Explosive Atmospheres or Hazardous (Classified) Locations only.

<p>Do not modify or repair explosion proof joints. Modifying explosion proof joints may produce an explosion hazard.</p> <p>To avoid injury from fire, explosion, or electric shock, all electrical wiring must be done by a qualified electrician and comply with all local codes and regulations.</p>				

Requirements for Explosion Proof Equipment

Use appropriate conduits, connectors, and cable glands rated for Class I, Division I, Group D. Follow all national, state, and local electric codes and regulations.

Cable rating requirement: 158°F (70°C) minimum (all cables)

Cable gland rating requirement: 158°F (70°C) minimum (all glands)

Requirements for Flame Proof Equipment

Use appropriate conduits, connectors, and cable glands rated for Ex II 2 G. Follow all national, state, and local electric codes and regulations.

Cable rating requirement: 158°F (70°C) minimum (all cables)

Cable gland rating requirement: 158°F (70°C) minimum (all glands)

Adapters for Plugs and Cables

<p>To avoid injury from fire, explosion, or electric shock, all electrical wiring must be done by a qualified electrician and comply with all local codes and regulations.</p>				

Use adapters as needed. Follow local codes and regulations.

Adapters are available (purchase separately).

Plug Adapters			
Region	Part		Plug Adapter
	C14 Plugs	C20 Plugs	
Europe	242001	15G958	
Australia, China	242005	17A242	
Italy	---	15G959	
Italy	287121 Kit contains all three C14 Plugs	---	
Switzerland		15G961	
Denmark		---	

Plug Retainer Clips	
Plug	Part
C14 Plugs	195551
C20 Plugs	121249

I/O Port Flying Lead Cable Adapters (for models in Ordinary Locations only)	
Cable Length	Part
6.5 ft (2 m)	123846
50 ft (15 m)	17D160
98 ft (30 m)	17B590

I/O Pin Connection

				
<p>To avoid injury from fire, explosion, or electric shock, all electrical wiring must be done by a qualified electrician and comply with all local codes and regulations.</p>				

For models in Ordinary Locations only.

NOTE: All I/O connectors are capable of 30 VDC (volts of direct current) and are reverse-polarity protected.

For wiring, see **Equivalent Electrical Circuits for I/O Pin Connection**, page 23.

I/O Connector Pinout (for Models in Ordinary Locations only)		
Pin	Connector Type	Description
Pin 1 (Brown)	Digital Input	Digital input has an internal 5 VDC pull-up for dry-contact or current-sinking circuits. Digital input is internally clamped for push-pull outputs. Release or drive the input high to stop the equipment from running. Pull the input low to re-enable the equipment.
Pin 2 (White)	Digital Output (Equipment Running)	Digital output is current-sinking with a current capacity up to 100 mA. Digital output is internally clamped for driving large inductive loads. The output is automatically pulled low when the equipment is running and automatically released when the equipment is not running.
Pin 3 (Blue)	GND/Common	Earth ground, common connection.
Pin 4 (Black)	Analog Input, Positive	<p>Analog inputs are 4–20 mA current-controlled. When the analog input is connected and driving current, the equipment disables the control knob (K) and uses the analog input to control the speed and pressure of the equipment. The control knob (K) can still be used to shut off the equipment by turning the knob to off (0). To re-enable the equipment at the speed and pressure commanded by the analog input, turn the control knob up (clockwise).</p> <p>To disable the analog input control and enable the control knob (K):</p> <ol style="list-style-type: none"> 1. Shut down the equipment. See Shut Down the Equipment, page 27. Ensure the LED indicator is off (no light). 2. Disconnect power to the system. 3. Disconnect the analog input (Pin 4, Pin 5). 4. Connect the unit to a power source to turn on the equipment and enable the control knob (K) on the equipment.
Pin 5 (Gray)	Analog Input, Negative	

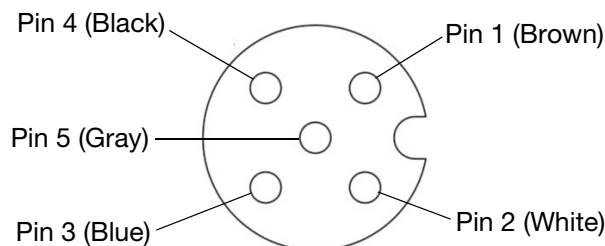

FIG. 11: M12, 5-pin Connector for Models in Ordinary Locations
Orientation: facing the connector on the pump body.

Equivalent Electrical Circuits for I/O Pin Connection

Equivalent Electrical Circuits for I/O Pin Connection (for Models in Ordinary Locations only)	
I/O Circuit	Equivalent Circuit
Digital Input	<p>Logic: Low (Run) < 2.0 V High (Stop) > 3.0 V</p> <p>Maximum 30 VDC</p>
Compatible Drivers for Digital Input	
Switch or Relay	
Open Collector (NPN)	
Push-Pull Driver	<p>Maximum 30 VDC</p>

Equivalent Electrical Circuits for I/O Pin Connection (for Models in Ordinary Locations only)	
I/O Circuit	Equivalent Circuit
Digital Output	<p>Maximum 30 VDC, Maximum 100 mA</p> <p>Logic: Pump Running: Active Pump Stopped: Inactive</p>
Compatible Digital Output Circuit Drivers	
PLC With Internal Pull-up	<p>100 mA Max</p>
PLC without Internal Pull-up	<p>100 mA Max</p>

Equivalent Electrical Circuits for I/O Pin Connection (for Models in Ordinary Locations only)	
I/O Circuit	Equivalent Circuit
Digital Output	<p>Relay or Solenoid</p>
	<p>LED</p>
	<p>Lamp</p>
Analog Input	<p>Maximum 30 VDC</p>

Operation

Pressure Relief Procedure

 Follow the Pressure Relief Procedure whenever you see this symbol.



This equipment stays pressurized until pressure is manually relieved. To help prevent serious injury from pressurized fluid, such as splashing fluid and moving parts, follow the **Pressure Relief Procedure** when you stop operating and before cleaning, checking, or servicing the equipment.

1. Turn the fluid output control knob (K) to off (0) and disconnect power to the system.
2. Close the fluid shutoff valve (H).
3. Open the fluid drain valve (G) to relieve fluid pressure. Prepare a container to catch the drainage.
4. Leave the fluid drain valve (G) open until the system is ready to be pressurized.

Before Each Use

Tighten Fasteners

Check and tighten all fasteners before operating the equipment.

NOTICE

To avoid pump damage, do not over-tighten the fasteners on the equipment.

Tighten Connections

Check and tighten all fluid connections before operating the equipment. Replace worn or damaged parts as needed.

NOTICE

Firmly tighten all connections to avoid leaks and damage to equipment parts.

Flush the Equipment

Flush the equipment before each use. Determine whether to disassemble and clean individual parts or simply flush the equipment with a compatible sanitizing solution.

To simply flush the equipment with a compatible sanitizing solution, follow **Start the Equipment**, page 25, and **Flush the Equipment**, page 31.

To disassemble and clean individual parts, see the applicable repair procedure. See **Repair**, starting on page 36.

Start the Equipment



To prevent serious injury from splashing fluid, ensure the control knob (K) is set to off (0) before connecting the equipment to a power source.

Prepare the Equipment for Startup

1. Turn the control knob (K) to off (0).
2. Confirm that the equipment is properly grounded. See **Grounding**, page 17.
3. Check and tighten all fasteners and connections before operating the equipment. Replace worn or damaged parts as needed.
4. Insert the suction end of the fluid supply line (F) into the fluid to be dispensed.
5. Insert the outlet end of the fluid outlet line (J) into the end container.
6. Close the fluid drain valve (G).
7. Ensure all fluid shutoff valves (H) are open.
8. If the fluid outlet line (J) has a dispensing device, hold the dispensing valve open into the end container.

Start and Adjust the Equipment

1. Follow **Prepare the Equipment for Startup**, page 25.
2. Connect the equipment to a power source. See **Electrical Connections and Wiring**, starting on page 19.

NOTE: The pump will automatically start cycling if the pump is connected to power and the control knob (K) is not set to off (0).

3. After the alert beep sounds, allow the equipment to complete the startup sequence. See **LED Indicator Overview**, page 28.

The LED indicator light illuminates solid yellow while calibrating. The pump cycles slowly while adjusting and operates normally after fully calibrating.

The system stays calibrated as long as power to the system is connected. If power to the system is disconnected, the system will automatically recalibrate after power is restored.

4. Slowly increase the control knob (K) until the equipment is operating at the set output level.
5. If flushing, run the equipment long enough to thoroughly clean the equipment and lines.

Tips to Reduce Cavitation

NOTICE

Frequent or excessive cavitation can cause serious damage, including pitting and early wear of wetted parts, and may result in reduced efficiency of the equipment. Cavitation damage and reduced efficiency both result in increased operating costs.

Cavitation is the formation and collapse of air pockets in the fluid. Cavitation depends on the vapor pressure of the fluid, the system suction pressure, and the velocity pressure. Viscous fluids are more difficult to pump and more prone to cavitation than non-viscous fluids.

To improve equipment efficiency and reduce the cavitation:

1. **Reduce vapor pressure:** Decrease the temperature of the fluid.
2. **Increase suction pressure:**
 - a. Position the equipment lower than the fluid level in the supply.

- b. Reduce the number of fittings on the suction lines to reduce friction length.
- c. Increase the diameter of the suction lines.
- d. Reduce the fluid inlet pressure. An inlet pressure supply of 3–5 psi (21–35 kPa, 0.2–0.3 bar) is adequate for most materials.

NOTICE

To avoid pump damage and inefficient operation, do not use a fluid inlet pressure greater than 25 percent of the outlet working pressure.

- e. Increase the Net Positive Suction Head (NPSH). See **Performance Charts**, page 46.

3. **Reduce liquid velocity:** Slow the equipment cyclic rate.

Consider all the previously listed factors in system design. To maintain efficiency, operate the equipment at the lowest speed and pressure setting needed for the required flow.

Contact your local distributor for site-specific suggestions to improve equipment performance and reduce operating costs.

Disable Auto-Prime

The auto-prime sensor detects fluid while the equipment is operating. The equipment will run as long as fluid is detected. If fluid is not detected, the auto-prime sequence will restart.

Auto-prime is enabled by default. To disable auto-prime:

1. Follow **Remove the Control Cover**, in the control cover repair procedures in the motor manual. See **Related Manuals** on page 3.
2. Locate the auto-prime switch (AP). See FIG. 12 or **Electrical Schematics** in the motor manual.
3. Push the auto-prime switch (AP) to the left (off) position.
4. Follow **Install the Control Cover** in the control cover repair procedures in the motor manual.

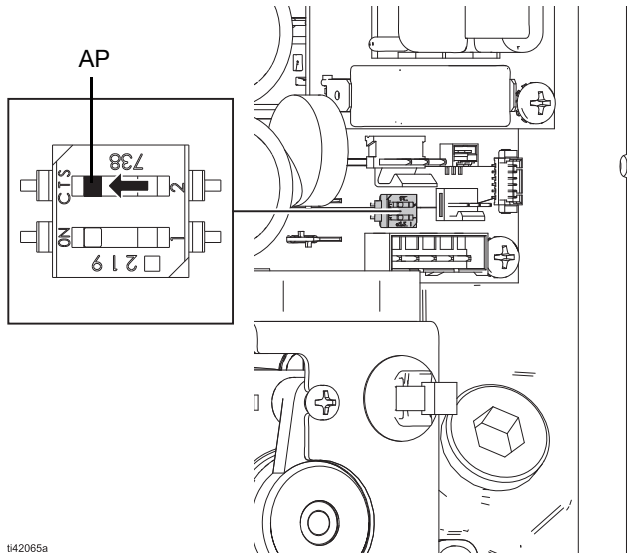

t42065a

FIG. 12: Disable Auto-Prime

Shut Down the Equipment



1. Follow **Pressure Relief Procedure**, page 25.
2. Follow **Flush the Equipment**, page 31.

LED Indicator

LED Indicator Overview

LED Indicator	Equipment Status	Notes
Red, solid	Powered on, speed set at 0 (zero), system not operating.	Be aware that the equipment is energized. To initiate equipment operation, follow Start the Equipment , page 25.
Red, flashing	Motor fault, motor error.	See LED Indicator Event Errors , page 29.
Yellow, solid	Calibrating. Performing startup sequence.	No action. Allow equipment to finish startup sequence. Open the fluid drain valve (G) or fluid shutoff valve (H) to allow the equipment to cycle until the startup sequence is finished.
Yellow, flashing	Leak sensor alert.	See "Leak sensor alert" in LED Indicator Event Errors , page 30.
Green, solid	Startup sequence complete.	To initiate equipment operation, follow Start the Equipment , page 25.
	Normal operation.	No action.
Green, flashing	Normal operation, stalled against pressure.	Be aware that the equipment is energized. Special-case action. See LED Indicator Event Errors , page 29.
No light (off)	System not powered.	See LED Indicator Event Errors , page 29.

LED Indicator Event Errors



If an event error occurs, the LED Indicator will blink a set number of times corresponding to the event code that needs acknowledged.

Follow the **Pressure Relief Procedure**, page 25, before checking or repairing the equipment.

Check all possible problems and causes before disassembling equipment.

LED Indicator Event Errors			
LED Indicator	Problem	Cause	Solution
Red, flashing, one flash	Motor or controller overheating.	Hot operating environment or hot operating conditions.	Turn the control knob (K) to the off (0) position. Keep the system connected to power and allow the equipment to cool before returning to operation.
			Inspect the fan. Repair or replace as needed. See your related motor manual. See Related Manuals , page 3.
Red, flashing, two flashes	Motor current error.	Special-case cause.	Turn control knob down, the back up. If the problem persists, contact Technical Support.
Red, flashing, three flashes	Voltage error or pump priming failure.	Input voltage is too high, too low, or too noisy, or an operational parameter of the motor was exceeded while priming.	Check line power voltage.
			Check control board connections. See your related motor manual. See Related Manuals , page 3.
			If the pump has flapper check valves, reduce the output pressure of the pump via a valve or the control knob (K). Pumps with flapper check valves are unable to prime fluid against pressure. If the problem persists or if the pump has ball check valves, examine all check valves to ensure they are checking and opening correctly.
Red, Flashing, four flashes	Motor sensor error.	Motor sensor disconnected.	Ensure the motor sensor cable is properly installed. See your related motor manual. See Related Manuals , page 3.
		Motor sensor not functioning.	Replace the motor sensor. See your related motor manual. See Related Manuals , page 3.

LED Indicator Event Errors			
LED Indicator	Problem	Cause	Solution
Red, flashing, five flashes	Special-case problem.	Special-case cause.	Power cycle the unit. If the error persists, contact Technical Support.
Red, flashing, six flashes	Motor lead connection error	One or more motor leads are connected incorrectly.	Check that all motor connections to the control board are correct.
Dim red, solid	Voltage detection error.	Power disconnected.	Check power connection.
		System powering down.	Allow equipment to finish shutdown.
Yellow, flashing, continuous flash	Leak sensor alert.*	Leak detected in the equipment.	Check the diaphragm for rupture or incorrect installation. Repair or replace. Ensure that the diaphragm is torqued to specification.
		The leak sensor disconnected.	Ensure the leak sensor is properly installed. See your related leak sensor manual. See Related Manuals , page 3.
Green, flashing, continuous flash	Equipment stalled against pressure.	A valve downstream in the fluid line is closed or clogged.	Open the valve.
			Follow the Pressure Relief Procedure , page 25, and clear the valve.
		Special-case cause.	Be aware that the equipment is energized. Special-case action. See your related motor manual. See Related Manuals , page 3.
No light (off)	Voltage detection error.	System not powered.	Contact Technical Support.
			Check power connection.
			Check the branch circuit for proper voltage.
			Replace the control board. See your related motor manual. See Related Manuals , page 3.

* A leak sensor is not provided with the equipment. Accessory kits are available (purchase separately). See your related motor manual. See **Related Manuals**, page 3.

Maintenance

Establish a Preventive Maintenance Schedule

NOTICE

Regularly maintain the equipment to avoid pump damage due to spills, leaks, or diaphragm failure.

Establish a preventive maintenance schedule based on the equipment service history.

Inspect the Equipment

Regularly inspect the equipment for worn or damaged parts. Replace as needed.

Tighten Fasteners

Regularly check and tighten all fasteners.

NOTICE

To avoid pump damage, do not over-tighten the fasteners on the equipment.

Tighten Connections

Check and tighten all fluid connections before operating the equipment. Replace worn or damaged parts as needed.

NOTICE

Firmly tighten all connections to avoid leaks and damage to equipment parts.

Lubricate the Equipment

The equipment is lubricated at the factory. Re-lubricate the equipment when replacing diaphragms.

Lubricate the motor rotor when replacing diaphragms. See your related motor manual. See **Related Manuals**, page 3.

NOTICE

Do not over-lubricate the equipment. Lubricant exhaust could contaminate your fluid supply or other equipment. Excessive lubrication can also cause the equipment to malfunction.

Flush the Equipment

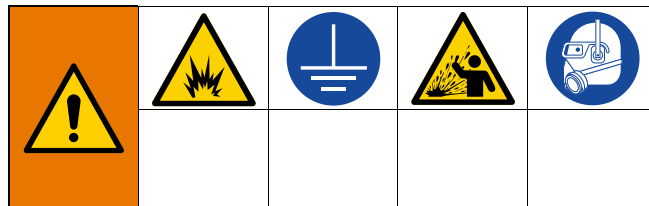

To avoid fire and explosion, always ground the equipment and waste container. To avoid static sparking and injury from splashing, always flush at the lowest possible pressure.

- Flush before fluid can dry or freeze in the equipment, at the end of the day, before storing, and before repairing equipment.
 - Flush at the lowest pressure possible. Check connections for leaks and tighten as needed.
 - Flush with a solvent that is compatible with the fluid being dispensed and the equipment wetted parts. Use a sanitary solution for hygienic applications.
 - Flushing schedule varies based on particular uses.
 - Always cycle the equipment during the entire flushing process.
1. Follow **Pressure Relief Procedure**, page 25.
 2. Insert the suction end of the fluid supply line (F) into a compatible sanitizing solution.
 3. Close the fluid drain valve (G).
 4. Ensure the control knob (K) is turned to off (0).
 5. If the fluid outlet line (J) has a dispensing device, place a metal part of the dispensing device to a grounded metal container and hold the dispensing valve open.
 6. Ensure all fluid shutoff valves (H) are open.
 7. Connect the equipment to a power source. See **Electrical Connections and Wiring**, starting on page 19.
 8. Slowly increase the control knob (K) until the equipment is operating at the set output level.
 9. Run the equipment for enough time to thoroughly clean the equipment and lines.
 10. Turn the control knob (K) to off (0).
 11. Follow **Pressure Relief Procedure**, page 25.

Store the Equipment



Always relieve the pressure and flush the equipment before storing the equipment for any length of time.

1. Follow **Pressure Relief Procedure**, page 25.
2. Follow **Flush the Equipment**, page 31.

NOTICE

Store the equipment at 32°F (0°C) or higher. Exposure to extreme low temperatures may result in damage to plastic parts.

Clean the Wetted Section



Routinely clean the wetted section. Determine whether or not to disassemble equipment for cleaning.

- To clean the equipment without disassembling parts, follow **Clean In-Place (CIP)**, page 32.
- To clean the equipment by disassembling parts, follow **Clean Out-of-Place (COP)**, page 32.

Clean in accordance with applicable sanitary standard codes and local regulations.

Clean In-Place (CIP)

NOTICE

To avoid equipment damage, only use cleaning fluids that are compatible with materials of the wetted section. To avoid damage to stainless steel parts, do not use chlorinated cleaning fluids. Do not exceed the maximum fluid temperature for the materials of the wetted section. See **Fluid Temperature Range**, page 60.

1. Follow **Pressure Relief Procedure**, page 25.
2. Flush the equipment with a compatible sanitizing solution. Follow **Flush the Equipment**, page 31.
3. Circulate the compatible sanitizing solution through the equipment. Slowly cycle the equipment as the compatible sanitizing solution is circulated.

NOTE: Thoroughly circulate the compatible sanitizing solution through the equipment and the system prior to use.

NOTICE

To avoid equipment damage, do not exceed a fluid inlet pressure of 15 psi (103 kPa, 1 bar) when cycling the equipment.

4. Follow **Pressure Relief Procedure**, page 25.

Clean Out-of-Place (COP)

1. Follow **Pressure Relief Procedure**, page 25.
2. Flush the equipment with a compatible sanitizing solution. Follow **Flush the Equipment**, page 31.
3. Disassemble parts as needed. See **Repair**, starting on page 36.
4. Inspect parts for wear or damage. Replace as needed.
5. Using a brush or other COP methods, wash all wetted parts with a compatible sanitizing solution at the recommended temperature and concentration of the manufacturer.
6. Rinse the parts again with water and allow parts to completely dry.
7. Inspect the parts and re-clean any soiled parts.
8. Immerse all wetted parts in an approved sanitizer before assembly. Leave the parts in the sanitizer, and only remove the parts one by one as needed for assembly.
9. Reassemble the equipment as needed. See **Repair**, starting on page 36.
10. Flush the equipment with a compatible sanitizing solution. Follow **Flush the Equipment**, page 31.
11. Circulate the compatible sanitizing solution through the equipment. Slowly cycle the equipment as the compatible sanitizing solution is circulated.

NOTE: Thoroughly circulate the compatible sanitizing solution through the equipment and the system prior to use.

NOTICE

To avoid equipment damage, do not exceed a fluid inlet pressure of 15 psi (103 kPa, 1 bar) when cycling the equipment.

12. Follow **Pressure Relief Procedure**, page 25.

Troubleshooting

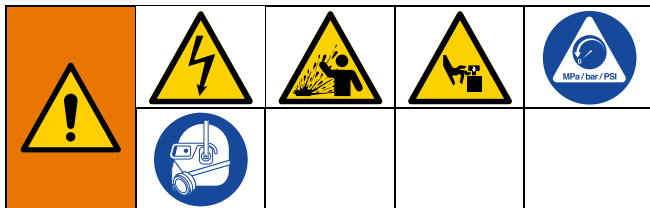

Follow the **Pressure Relief Procedure**, page 25, before checking or repairing the equipment.



Check all possible problems and causes before disassembling equipment.

Problem	Cause	Solution
Equipment emits beeping alert sound, LED light yellow	Pump starting automatic startup sequence. Pump is connected to a power source and the control knob (K) is not set to the off (0) position.	Turn the control knob (K) to the off (0) position or disconnect power to the system. If prepared to operate, allow the pump to complete the automatic startup sequence.
	LED light flashing	Equipment error; special-case cause. See LED Indicator Event Errors , page 29.
Equipment cycles, but does not prime or pump (It is normal operation for auto-prime to run and then stop once the pump is primed).	Equipment running too fast, causing cavitation before prime.	Slow down the motor speed.
	Fluid not detected by the auto-prime sensor.	Ensure the suction end of the fluid supply line (F) is inserted into the fluid to be dispensed. Allow the auto-prime sequence to run for 30 seconds.
	Check is worn or wedged in the seat or manifold.	Replace check and seat.
	Worn seat.	Replace check and seat.
	Restricted outlet or inlet port.	Remove restriction.
	Loose inlet fittings or manifolds.	Tighten.
Equipment does not hold fluid pressure at stall	Damaged manifold seats.	Replace.
	Worn check, seats, or seals.	Replace.
	Loose manifold connections or fluid connections.	Tighten.
Equipment leaking fluid externally from joints [‡]	Loose diaphragm shaft fastener.	Tighten.
	Loose manifold connections or fluid cover connections.	Tighten.
	Worn manifold seats or seals.	Replace.

Problem	Cause	Solution
Equipment leaks fluid externally from the joint between the center manifold and manifold. (Flapper pumps only)	Worn or damaged gaskets (53).	Replace gaskets (53), see Reassemble the Check Valves , page 40.
	Gasket (53) not installed properly. Manifold (5 or 4) not fully installed at joint to the center manifold (54).	Thoroughly grease the gasket (53) and the inner diameter of the manifold (5 or 4) before assembling manifold. Ensure the gasket (53) is fully installed on the outer diameter of the center manifold (54). Ensure the manifold (5 or 4) is properly aligned to the equipment. Ensure the center manifold (54) and manifold (5 or 4) are fully connected at the joint. See Reassemble the Check Valves , page 40.
Equipment stalled, will not cycle	Fluid line clogged or valves closed.	Inspect; clear. Open valves downstream of the equipment.
	Motor or controller wired improperly.	Wire per instructions in your related motor manual. See Related Manuals , page 3.
	Leak sensor tripped.	Check diaphragm for rupture or incorrect installation. Repair or replace.
Reduced performance	Fluid line clogged.	Inspect; clear.
	Checks are sticky or leaking.	Clean or replace.
	Diaphragm (or backup diaphragm, if applicable) ruptured.	Replace.
Air bubbles in fluid	Fluid line is loose.	Tighten.
	Diaphragm (or backup diaphragm, if applicable) ruptured.	Replace.
	Loose manifolds.	Tighten manifold fasteners or clamps.
	Damaged seats or seals.	Replace seats or seals.
	Loose diaphragm shaft fastener.	Tighten.
Fluid leaking from lower ports on the equipment or fluid on the floor.	Loose diaphragm shaft fastener.	Tighten.
	Diaphragm rupture. Leak in the equipment.	Replace.







Problem	Cause	Solution
Equipment suddenly stops operating or shuts down.	Ground fault circuit interrupter (GFCI) tripped.	Remove controller from the GFCI circuit.
	Poor supply power.	Check connections. Determine and fix the source of the problem with the supply power.
	Exceeded operational parameters.	See LED Indicator Event Errors , page 29, for event codes.
	Leak sensor* alert. Leak detected in the equipment.	Check the diaphragm for rupture or incorrect installation. Repair or replace.
	The leak sensor* disconnected.	Ensure the leak sensor is properly installed. See your related leak sensor manual.

* A leak sensor is not provided with the equipment. Accessory kits are available (purchase separately). See **Related Manuals**, page 3.

				
<p>‡ Do not modify or repair explosion proof joints. Modifying explosion proof joints will invalidate the Hazardous Location Certification of the equipment and may produce an explosion hazard.</p>				

Repair

NOTE: Repair kits are available (purchase separately).



				
				

This equipment stays pressurized until pressure is manually relieved. To help prevent serious injury from pressurized fluid, such as splashing fluid and moving parts, follow **Pressure Relief Procedure** when you stop operating and before cleaning, checking, or servicing the equipment.



To avoid severe burns, do not touch hot fluid or hot equipment.

Follow **Prepare Equipment for Repair**, page 36, before performing any service or repair to the equipment.

Prepare Equipment for Repair

				
-------------------------------------------------------------------------------------	-------------------------------------------------------------------------------------	-------------------------------------------------------------------------------------	--	--

To avoid injury from fire, explosion, or electric shock, all electrical wiring must be done by a qualified electrician and comply with all local codes and regulations.

				
-------------------------------------------------------------------------------------	-------------------------------------------------------------------------------------	--	--	--

Models in Explosive Atmospheres or Hazardous (Classified) Locations: To avoid injury from fire and explosion, move the equipment to a non-explosive or non-hazardous location before performing any service or repair to the equipment.

Always complete the following procedure before performing any service or repair to the equipment.

1. Follow **Pressure Relief Procedure**, page 25.
2. Follow **Flush the Equipment**, page 31.
3. Verify that the equipment is turned off and power to the system is disconnected before performing any service or repair procedure.

4. Disconnect all fluid lines.
5. Optional: Mount the back of the pump (opposite side from the motor) to the maintenance bracket stand (purchase separately). This positions the pump facing up, enabling easy working access to the pump and motor. The stand can be mounted to a workbench through the mounting holes on the feet. See FIG. 13.
 - a. Loosen the four bolts that hold the logo plate (if present) to the pump.
 - b. Slide the bracket stand behind the bolts.
 - c. Tighten the bolts.
 - d. After repairing the pump, remove the pump from the bracket stand and return it to service.

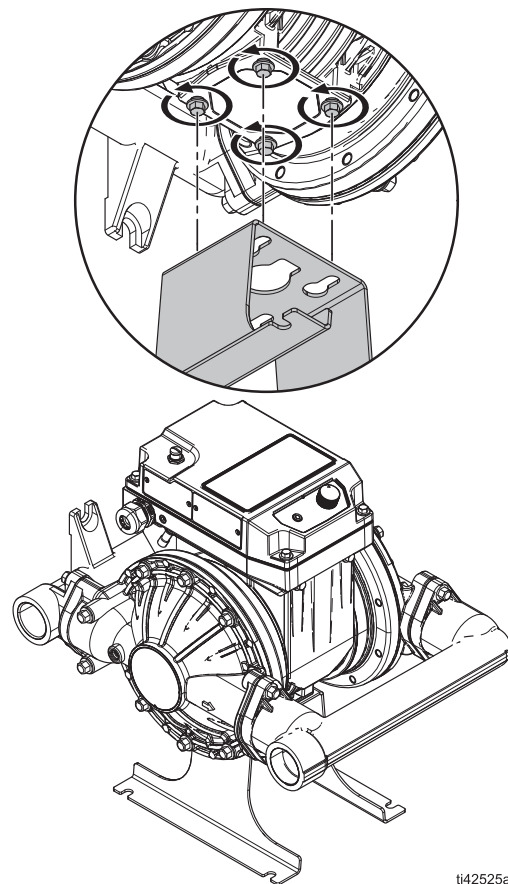

ti42525a

Fig. 13. Maintenance bracket stand

Repair the Check Valves (Ball Pumps)

Disassemble the Check Valves

				
To avoid severe burns, do not touch hot fluid or hot equipment.				

1. Follow **Prepare Equipment for Repair**, page 36.
2. Drain the equipment.

For equipment with a rotating stand: Remove the quick-release pins (29b) and rotate the equipment to drain. See FIG. 14.

NOTE: After draining, rotate the equipment to positions which will aid disassembly.

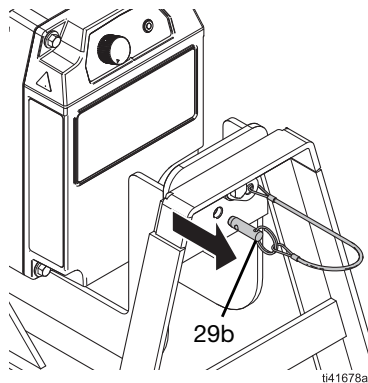

FIG. 14: Quick Release Pin, Rotating Stand

3. On the outlet manifold (4), remove all clamps (7a).
4. Remove the outlet manifold (4), seals (10, if applicable), checks (9 or 9c), and seats (8, if applicable).

NOTE: Use care while removing manifolds to avoid damage to check valve components.

5. On the inlet manifold (5), remove all clamps (7a).
6. Remove the inlet manifold (5), seals (10, if applicable), checks (9 or 9c), and seats (8, if applicable).

NOTE: Use care while removing manifolds to avoid damage to check valve components.

7. Clean and inspect parts for wear or damage. Replace as needed.

Reassemble the Check Valves

1. Align and place seats (8, if applicable), checks (9 or 9c), seals (10, if applicable), and manifolds (4, 5), exactly as shown for your equipment model. See your related parts manual. See **Related Manuals**, page 3.
2. Use the clamps (7a) to loosely attach the manifolds (4, 5) to the fluid covers (3). After all components are properly aligned, securely tighten the clamps (7a).

 Lubricate clamps (7a) and seals (10) with a waterproof, sanitary lubricant.

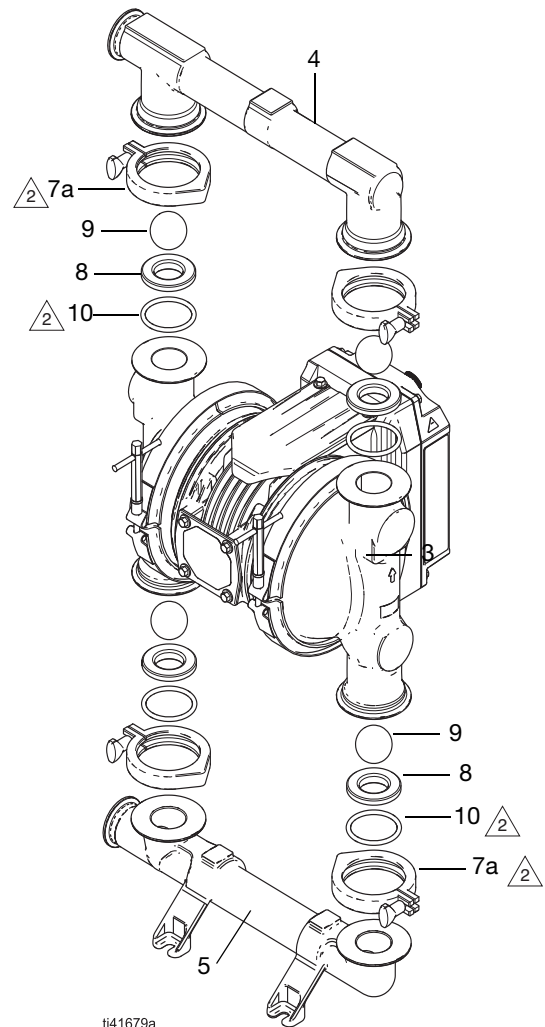

FIG. 15. Check Valves (FG Ball Pumps)

- 1 Lubricate clamps (7a) and seals (10) with a waterproof, sanitary lubricant.

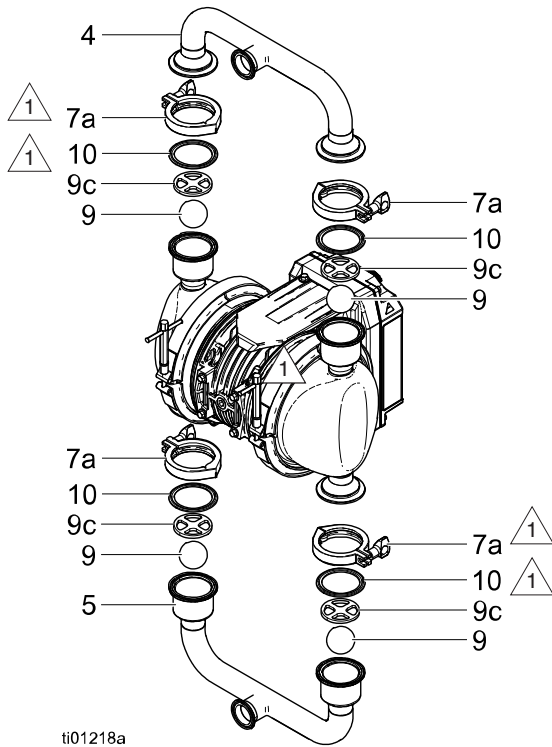

FIG. 16: Check Valves (HS Ball Pumps)

Repair the Check Valves (Flapper Pumps)

See parts manual in **Related Manuals**, page 3, for available repair kits. Service the check valves as follows.

See FIG. 17.

Disassemble the Check Valves

				
To avoid severe burns, do not touch hot fluid or hot equipment.				

1. Follow **Prepare Equipment for Repair**, page 36.
2. Drain the equipment.

For equipment with a rotating stand: Remove the quick-release pins (29b) and rotate the equipment to drain. See FIG. 14.

NOTE: After draining, rotate the equipment to positions which will aid disassembly.

3. Remove the clamps (7a) on the outlet manifold and remove the manifold (4), see FIG. 17, or remove manifold (4) assembly, see FIG. 18.
4. Remove remaining clamps, manifolds, gaskets and check valves.
5. Remove gaskets and check valves, disassembling the manifold assemblies as necessary.

NOTE: Inspect all components for any damage and replace as necessary.

6. To continue with diaphragm disassembly, see **Repair the Standard Diaphragms**, page 40.

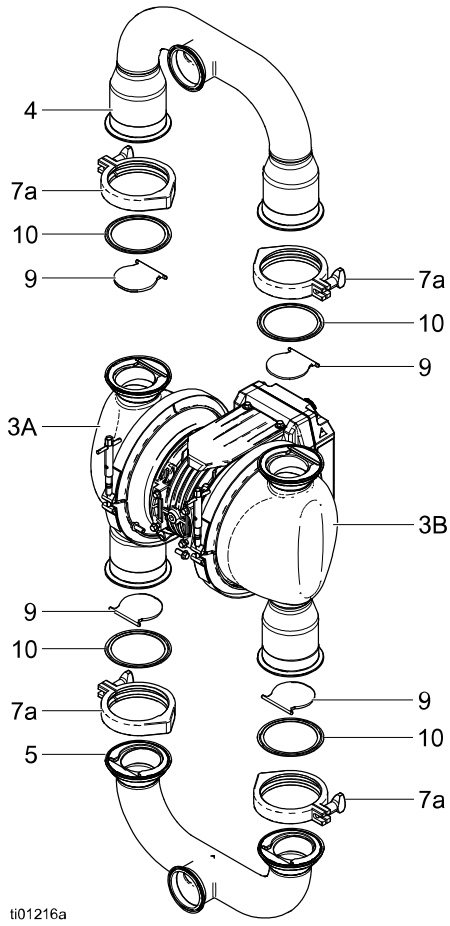

FIG. 17. Check Valves (Vertical Flapper Pump)

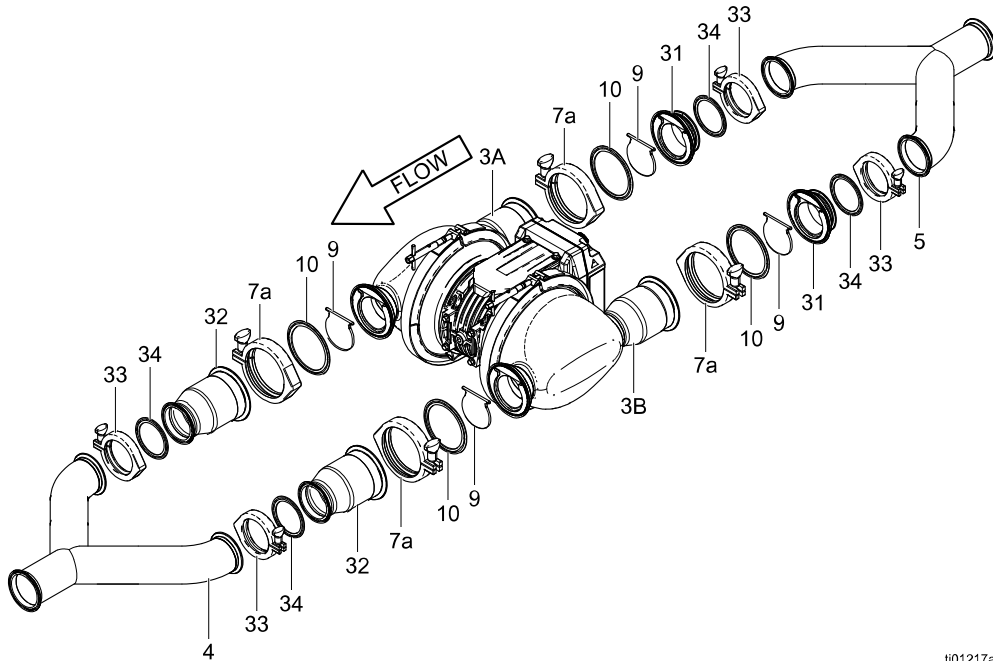
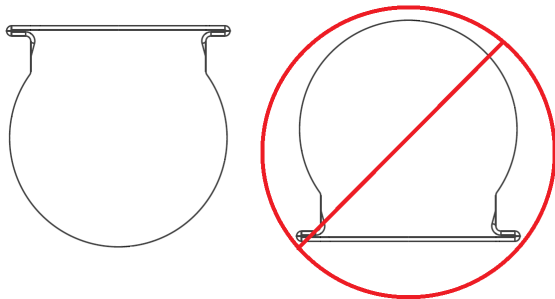

FIG. 18. Check Valves (Horizontal Flapper Pump)

Reassemble the Check Valves

1. Lubricate clamps and clamping surfaces with waterproof, sanitary lubricant.
2. Reassemble check assembly in reverse order of disassembly.
3. Loosely attach the manifolds to the fluid covers. Once all components are properly aligned, tighten clamps hand tight.

NOTE: Flapper fluid covers are not interchangeable, and their orientation is critical on horizontal pumps. Horizontal pump fluid covers must be positioned so that the flappers hang down from the hinge pin when placed in the fluid cover. Install the flapper valves (8) with the text side facing the seat.



Repair the Standard Diaphragms

Required Tools:

- Torque wrench
- 25 mm open-end wrench
- Lubriplate® Synxtreme HD-2 grease (part number 18F990) or equivalent NLGI Grade 2 synthetic grease with calcium sulfonate base
- 15 mm hex wrench

See FIG. 19–FIG. 21.

NOTE: Lubricate the motor rotor when replacing diaphragms. See your related motor manual. See **Related Manuals**, page 3.

Disassemble the Standard Diaphragms

To avoid severe burns, do not touch hot fluid or hot equipment.				

1. Follow **Prepare Equipment for Repair**, page 36.
2. Follow **Disassemble the Check Valves**, page 37.
3. Remove all clamps (6a) from the fluid covers (3). Remove the fluid covers (3).
4. Use an applicable wrench to firmly hold one diaphragm fastener (15) in place. At the same time, use an applicable wrench to loosen the fastener (15) on the opposite side.
5. Remove the fastener (15), seal (16, if applicable), fluid plate (11), diaphragm (13), and diaphragm backer (14) from the shaft (1a) on the side of the pump with the loosened fastener (15).
6. Loosen the remaining diaphragm fastener (15).

If the first loosened diaphragm fastener (15) is on the side of the shaft (1a) with the wrench flat:

- a. Use an applicable wrench to firmly hold the flat of the shaft (1a) in place. At the same time, use an applicable wrench to loosen the remaining diaphragm fastener (15). See FIG. 21.

If the first loosened diaphragm fastener (15) is opposite the wrench flat on the shaft (1a):

- a. Follow the procedure to lubricate the rotor in your related motor manual to access the flat of the shaft (1a). See **Related Manuals**, page 3.
 - b. After the flat of the shaft (1a) is accessible, use an applicable wrench to firmly hold the flat of the shaft (1a) in place. At the same time, use an applicable wrench to loosen the remaining diaphragm fastener (15). See FIG. 21.
7. Remove the remaining fastener (15), seal (16, if applicable), fluid plate (11), diaphragm (13), and diaphragm backer (14), and air-side plate (30) from the shaft (1a).

NOTE: Do not remove the diaphragm shaft (1a) from the motor (1).

NOTICE

To avoid damage to the rotor or equipment, do not remove the shaft (1a) from the motor (1). Removing the shaft will cause the rotor balls to dislodge from the rotor and the rotor will not function properly.

8. Clean and inspect parts for wear or damage. Replace parts as needed.
9. Lubricate the rotor. See your related motor manual. See **Related Manuals**, page 3.

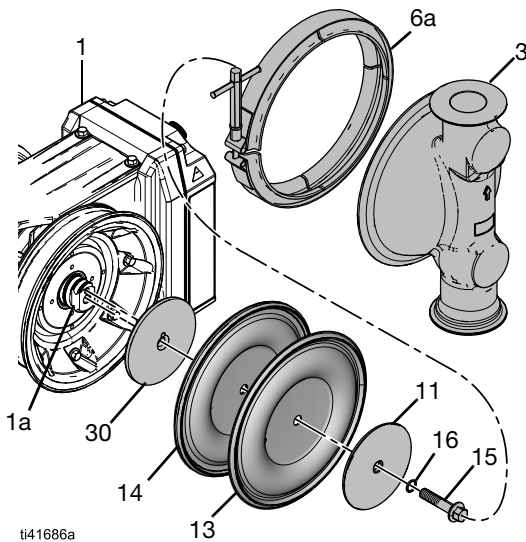

FIG. 19: Standard Diaphragms

Reassemble the Standard Diaphragms

NOTICE

After reassembly, allow the thread locker to cure for 12 hours, or per instructions of the manufacturer, prior to operating the equipment. The equipment will be damaged if the diaphragm shaft fastener loosens.

1. Assemble the air-side plates (30) diaphragm backers (14), diaphragms (13), fluid side plates (11), and seals (16, if applicable) with the fasteners (15) exactly as shown for your equipment model. See your related parts manual. See **Related Manuals**, page 3.

NOTE: Face the rounded side of the fluid side plate (11) toward the diaphragm (13).

NOTE: Regardless of any markings on the diaphragm backer (14), always assemble the diaphragm backer (14) so that the outer bead cups around (not away from) the outer bead of the diaphragm (13)

NOTE: Apply thread locker to the fastener (15) for all diaphragm assemblies.

- 1 Apply a medium-strength thread locker to the shaft side of the fastener to attach the diaphragm to the shaft.
- 2 Rounded side faces toward the diaphragm (13).

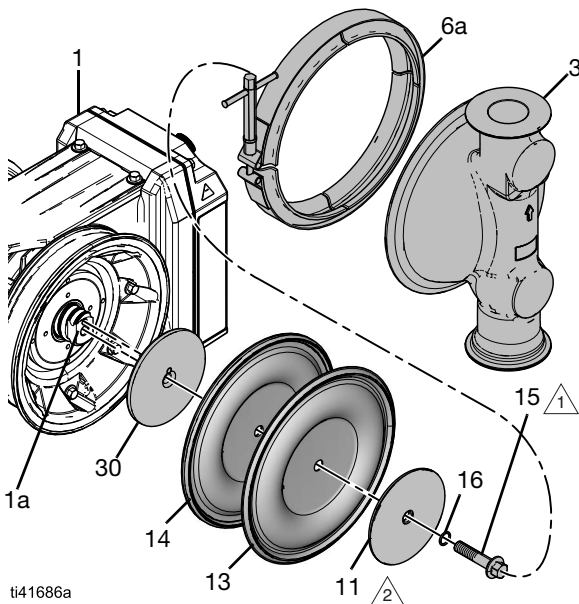
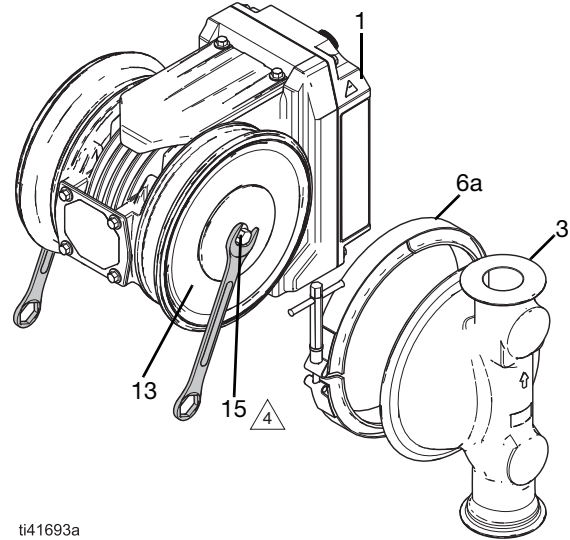

FIG. 20: Reassemble Standard Diaphragms (Hygienic Model Shown)

2. Install the assembled diaphragm assemblies into the shaft (1a) and hand-tighten the fasteners (15).

3. Use an applicable wrench to firmly hold one fastener (15) in place. At the same time, use an applicable wrench to torque the opposite fastener (15) to 50 ft-lb (68 N•m). See FIG. 21.

4 Torque to 50 ft-lb (68 N•m).



ti41693a

FIG. 21: Tighten Standard Diaphragms

4. Rotate the shaft of the motor to center it in the motor, so that neither diaphragm is extended away from the housing, which could inhibit installing the fluid covers.

NOTE: If it is not possible for both diaphragms to be in contact with the housing, choose one diaphragm to position first. Once the first fluid cover is fastened, slowly drive the motor so that the other diaphragm is in contact with the housing. Then fasten the second fluid cover.

5. Align the fluid covers (3) to the motor (1).
6. Install clamps (6a) to hold the fluid covers (3) in place.

NOTE: To ensure proper spacing and alignment of the manifolds, install clamps (6a) loose enough to allow for fluid cover movement before securing the fluid covers in place.

7. Reassemble the check valves and manifolds as explained in **Reassemble the Check Valves**, page 37.

Repair the Overmolded Diaphragms

Required Tools:

- Torque wrench
- 25 mm open-end wrench
- Lubriplate® Synxtreme HD-2 grease (part number 18F990) or equivalent NLGI Grade 2 synthetic grease with calcium sulfonate base

See FIG. 22–FIG. 24.

NOTE: Lubricate the motor rotor when replacing diaphragms. See your related motor manual. See **Related Manuals**, page 3.

Disassemble the Overmolded Diaphragms

				
To avoid severe burns, do not touch hot fluid or hot equipment.				

1. Follow **Prepare Equipment for Repair**, page 36.
2. Follow **Disassemble the Check Valves**, page 37.
3. Remove all clamps (7) from the fluid covers (3). Remove the fluid covers (3).
4. Firmly grip the outer edge of a diaphragm (13) to hold in place. At the same time, securely grip the outer edge of the opposite diaphragm (13) and rotate counterclockwise to loosen. Remove the diaphragm (13).

NOTE: If needed, leave one fluid cover fastened. With one diaphragm exposed, use both hands to loosen the exposed diaphragm.

NOTE: Do not remove the diaphragm shaft (1a) from the motor (1).

NOTICE
To avoid damage to the rotor or equipment, do not remove the shaft (1a) from the motor (1). Removing the shaft will cause the rotor balls to dislodge from the rotor and the rotor will not function properly.

5. Remove the remaining diaphragm (13).

If the first loosened diaphragm (13) is on the side of the shaft (1a) with the wrench flat:

- a. Use an applicable wrench to firmly hold the flat of the shaft (1a) in place. At the same time, securely grip the outer edge of the opposite diaphragm (13) and rotate counterclockwise to loosen.

If the first loosened diaphragm (13) is opposite the wrench flat on the shaft (1a):

- a. Follow the procedure to lubricate the rotor in your related motor manual to access the flat of the shaft (1a). See **Related Manuals**, page 3.
- b. After the flat of the shaft (1a) is accessible, use an applicable wrench to firmly hold the flat of the shaft (1a) in place. At the same time, securely grip the outer edge of the opposite diaphragm (13) and rotate counterclockwise to loosen.

6. Clean and inspect parts for wear or damage. Replace parts as needed.
7. Lubricate the rotor. See your related motor manual. See **Related Manuals**, page 3.

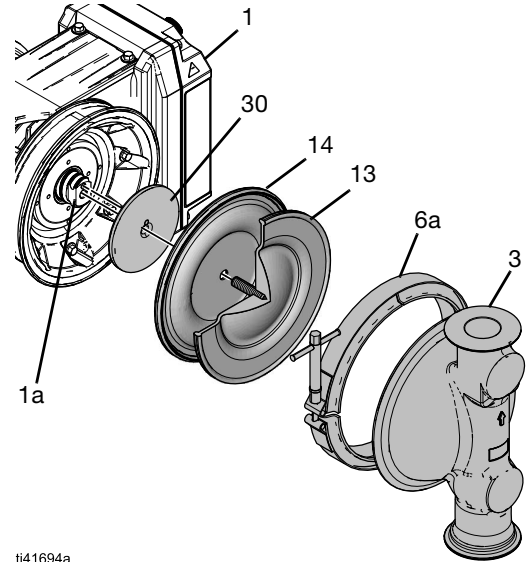

ti41694a
Fig. 22: Overmolded Diaphragms

Reassemble the Overmolded Diaphragms

NOTICE

After reassembly, allow the thread locker to cure for 12 hours, or per instructions of the manufacturer, prior to operating the equipment. The equipment will be damaged if the diaphragm shaft fastener loosens.

1. On the side of the shaft (1a) opposite of the wrench flat, install the air-side plate (30), diaphragm backer (14), and diaphragm assembly (13, 15) into the shaft (1a). Firmly tighten.

NOTE: Regardless of any markings on the diaphragm backer (14), always assemble the diaphragm backer (14) so that the outer bead cups around (not away from) the outer bead of the diaphragm (13).

NOTE: Apply thread locker to the fastener (15) for all diaphragm assemblies.

- 1 Apply a medium-strength thread locker to the shaft side of the fastener to attach the diaphragm to the shaft.

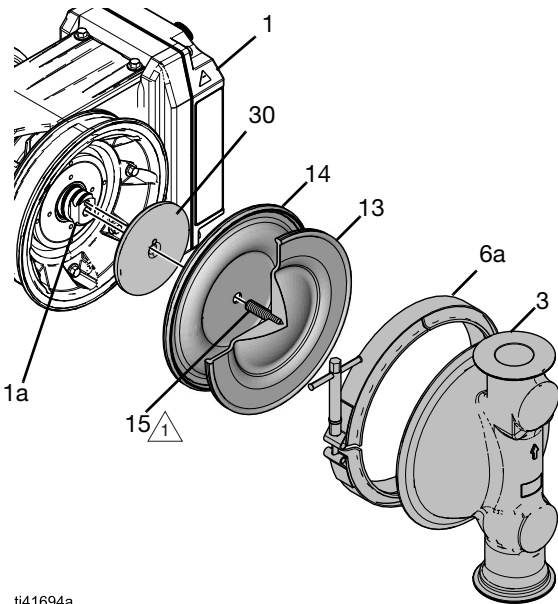

ti41694a

FIG. 23: Reassemble Overmolded Diaphragms

2. Use an applicable wrench to hold flat of the shaft (1a) firmly in place. At the same time, grip the diaphragm (13) securely around the outer edge and rotate clockwise to firmly tighten.
3. Rotate the shaft (1a) until it is centered in the motor (1).

NOTE: If it is not possible for both diaphragms to be in contact with the housing, choose one diaphragm to position first. Once the first fluid cover is fastened, slowly drive the motor so that the other diaphragm is in contact with the housing. Then fasten the second fluid cover.

4. On the side of the equipment with the installed diaphragm, align the fluid cover (3) to the motor (1).
5. Loosely install the clamp (6a) to hold the fluid cover (3) in place.
6. On the side of the shaft (1a) with the wrench flat, install the air-side plate (30), diaphragm backer (14), and diaphragm assembly (13, 15) into the shaft (1a). Firmly tighten.
7. Align the fluid cover (3) to the motor (1).
8. Loosely install the clamp (6a) to hold the fluid cover (3) in place.

NOTE: To ensure proper spacing and alignment of the manifolds (4, 5), install clamps (6a) loose enough to allow for fluid cover movement before securing the fluid covers (3) in place.

9. Securely tighten the clamps (6a).
10. Reassemble the check valves and manifolds as explained in **Reassemble the Check Valves**, page 37.

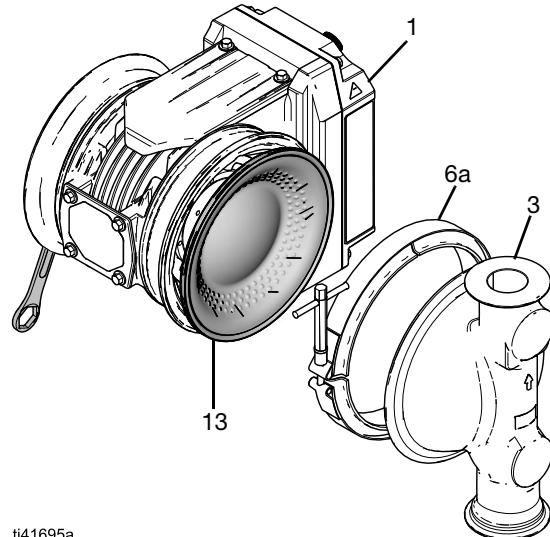

ti41695a

FIG. 24: Tighten Overmolded Diaphragms

Recycling and Disposal

At the end of the useful life of the equipment, disassemble and recycle the equipment in a responsible manner.

- Follow **Pressure Relief Procedure**, page 25.
- Drain and dispose of fluids according to applicable regulations. See the Safety Data Sheet (SDS) of the material manufacturer.
- Remove motors, circuit boards, LCDs (liquid crystal displays), and other electronic components. Recycle according to applicable regulations.
- Do not dispose of electronic components with household or commercial waste.



- Deliver remaining equipment to a recycling facility.

Performance Charts

Performance may vary based on pump materials, suction condition, discharge pressure, and fluid type.

Reference	Control Knob Setting
A	100%
B	80%
C	60%
D	40%
E	20%

Performance Chart for h30 (QHC) Models

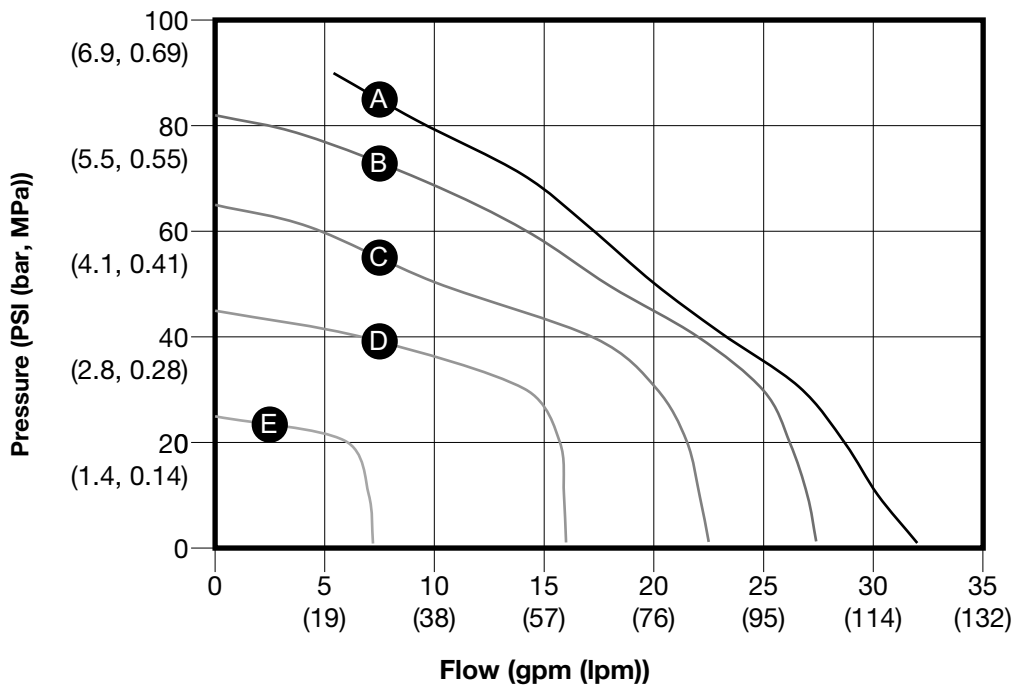

Performance Chart for h80 (QHD) Ball Models

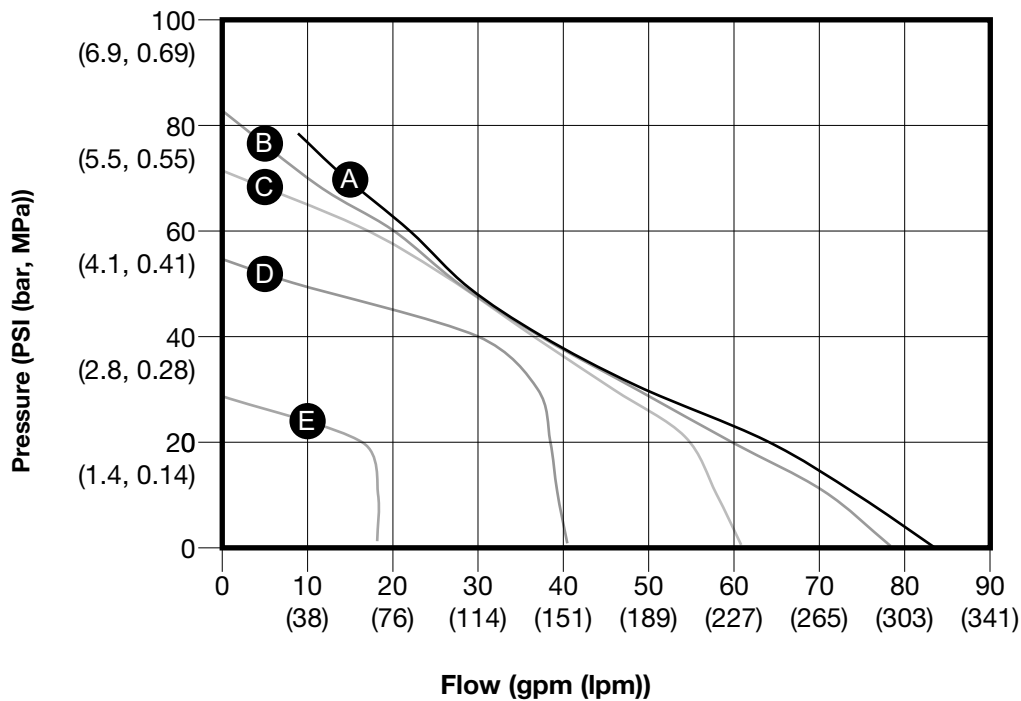

Performance Chart for h80 (QHD) Flapper Models

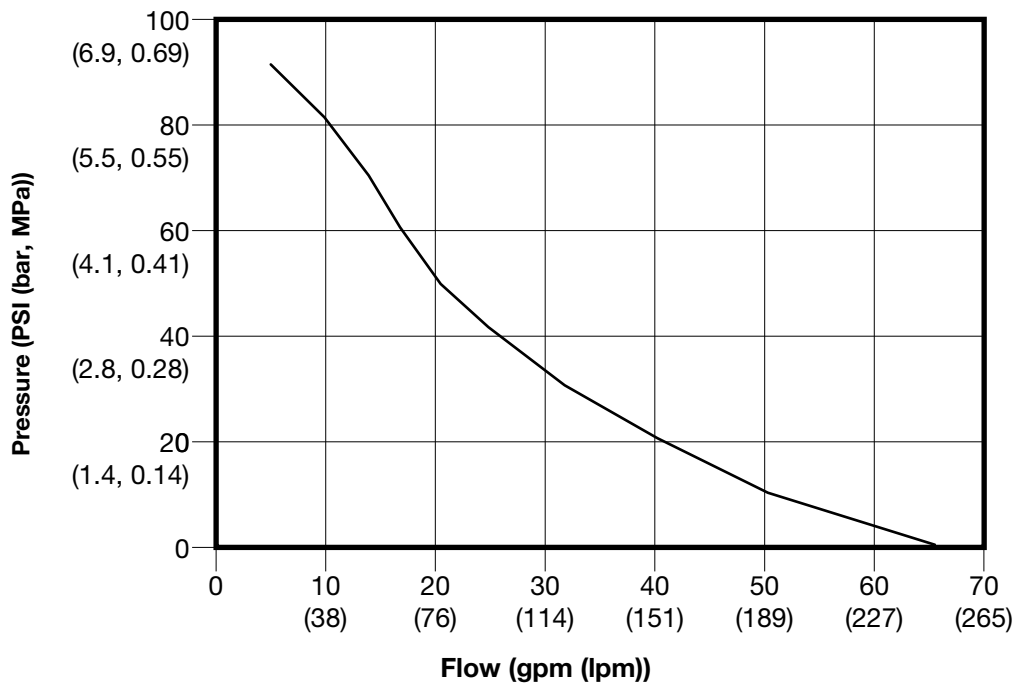

Performance Chart for h120 (QHE) Ball Models

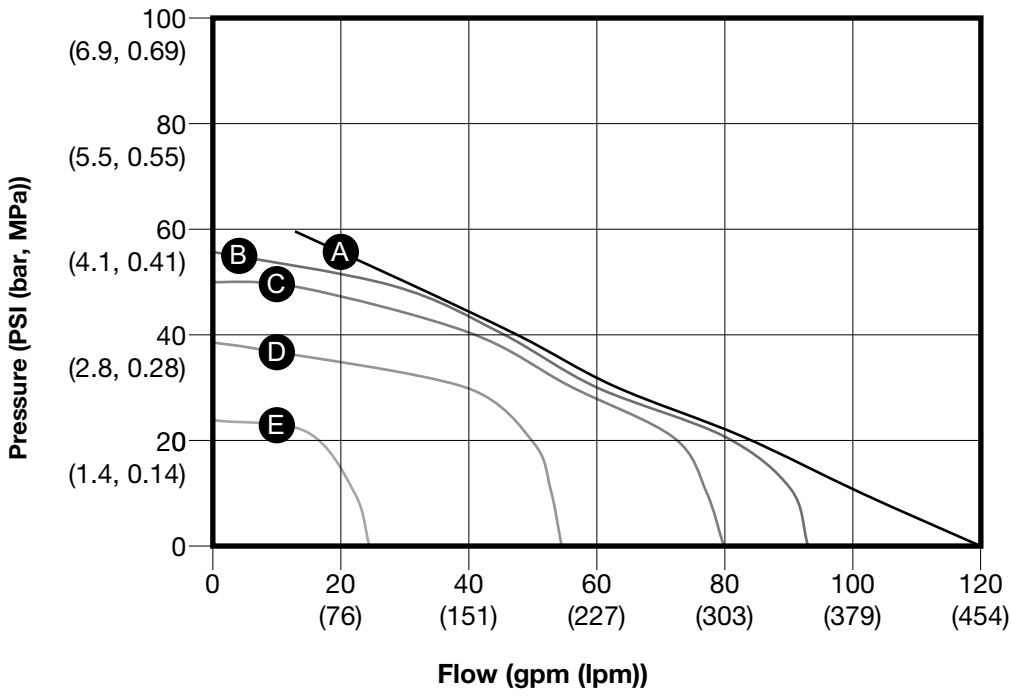

Performance Chart for h120 (QHE) Flapper Models

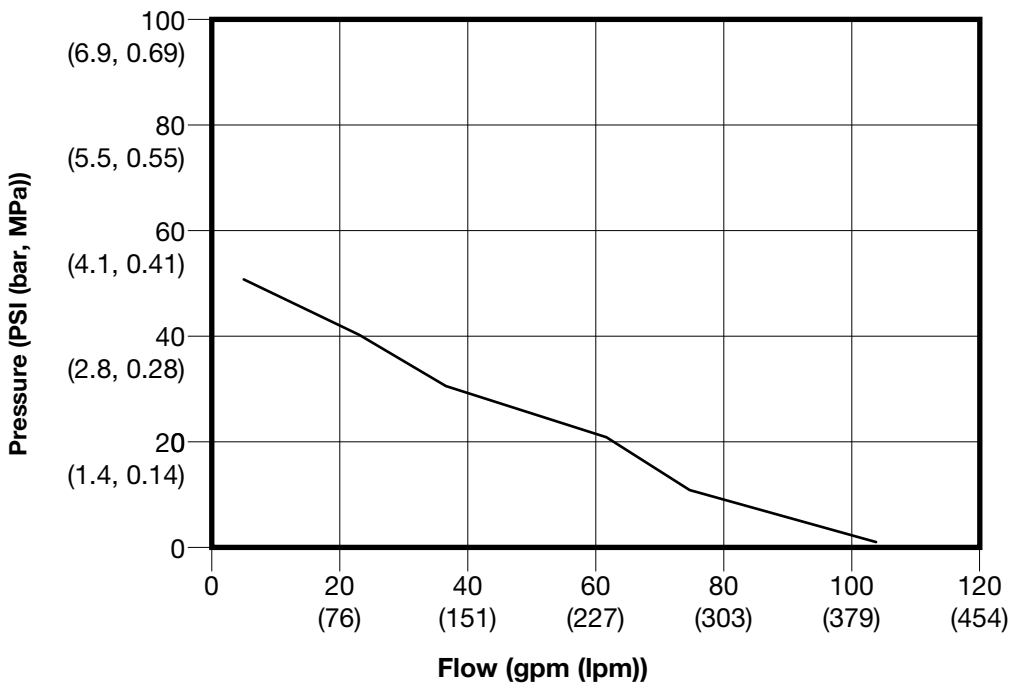

Dimensions

Dimensions for h30 (QHC) Models

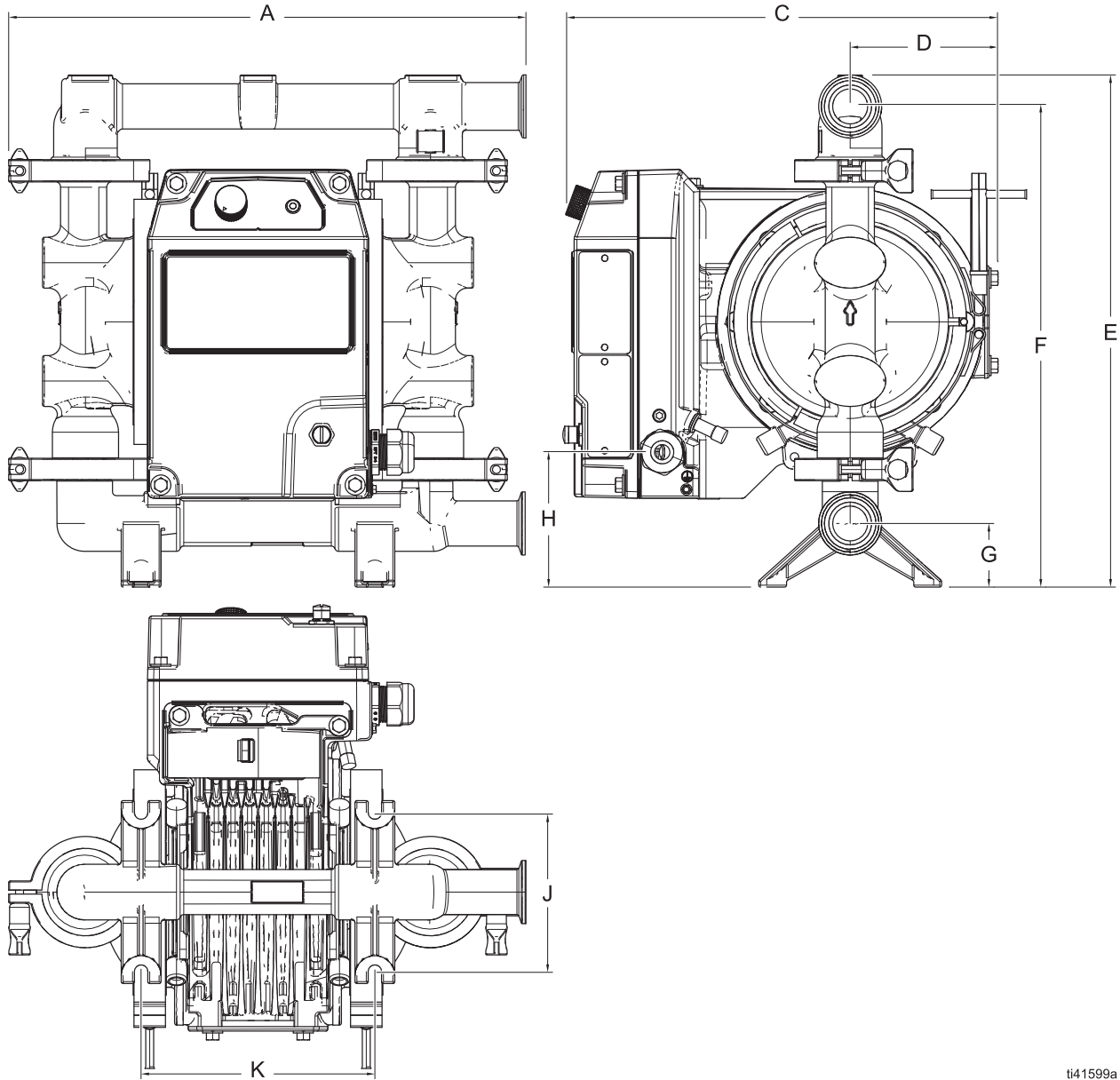

ti41599a

Fig. 25: h30 (QHC) Hygienic Model Dimensions (FG model shown)

Dimensions

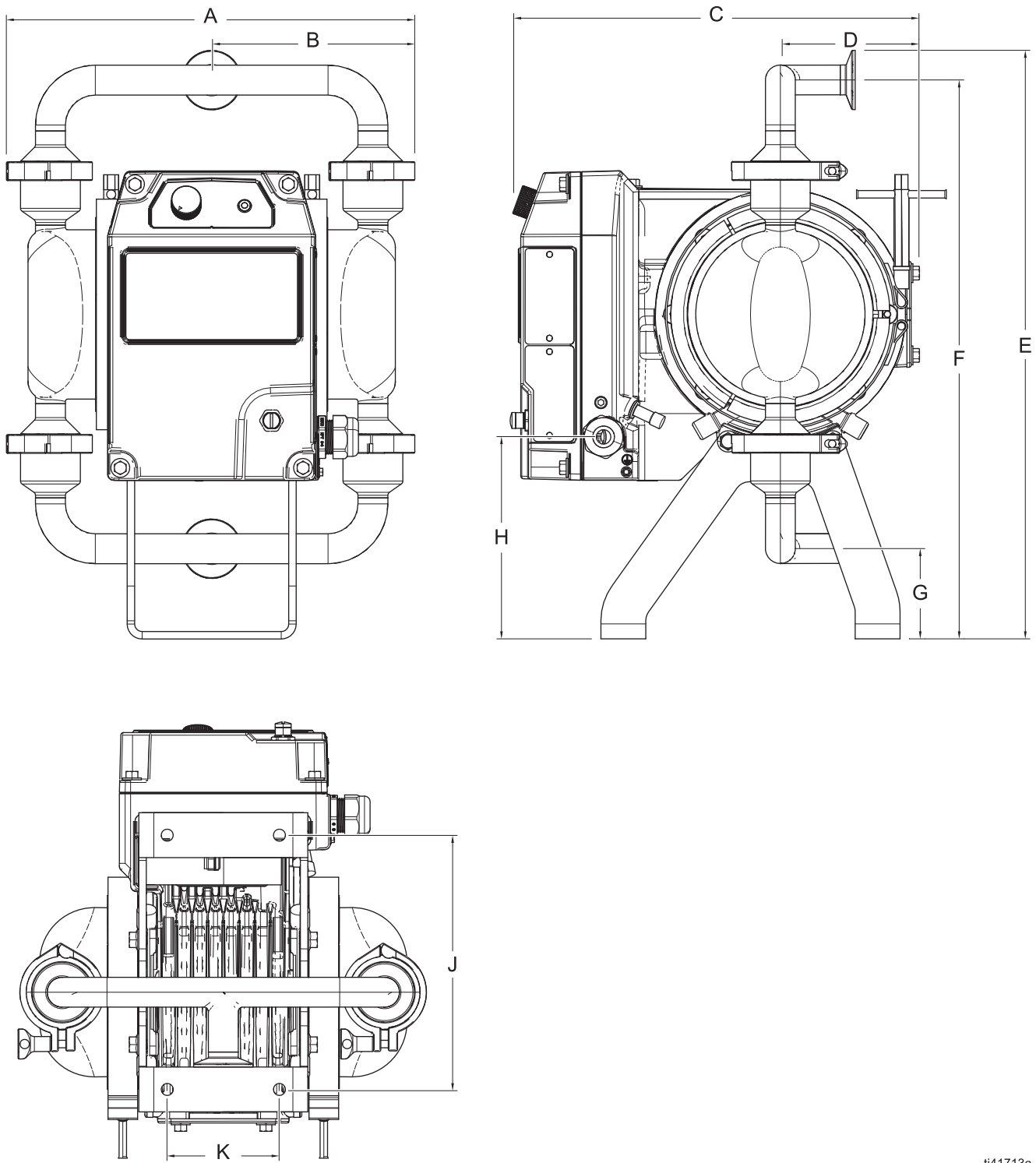

ti41713a

FIG. 26: h30 (QHC) Model Dimensions (HS model shown)

h30 (QHC) Model Dimensions				
Ref.	Wetted Section Material			
	FG		HS, PH, 3A	
	in.	cm	in.	cm
A	16.30	41.40	14.70	37.34
B	---	---	7.35	18.67
C	13.60	34.54	13.60	34.54
D	4.65	11.81	9.10	23.11
E	16.10	40.90	19.68	49.99
F	15.12	38.40	18.68	47.45
G	2.00	5.08	3.02	7.67
H	4.24	10.77	6.75	17.15
J	5.00	12.70	8.50	21.59
K	7.35	18.67	3.75	9.53

Dimensions for h80 (QHD) Models

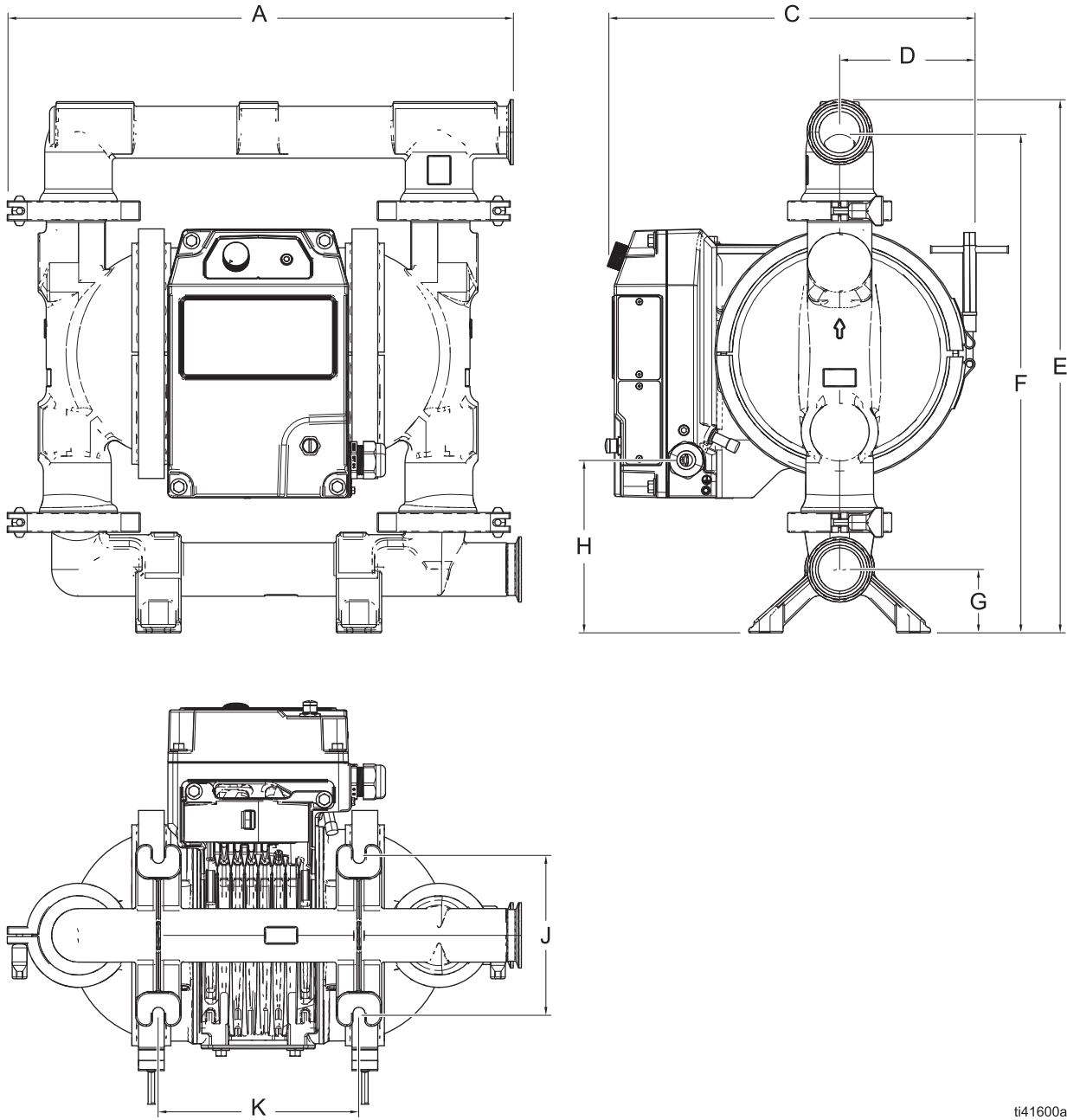

ti41600a

FIG. 27: h80 (QHD) Model Dimensions (FG model shown)

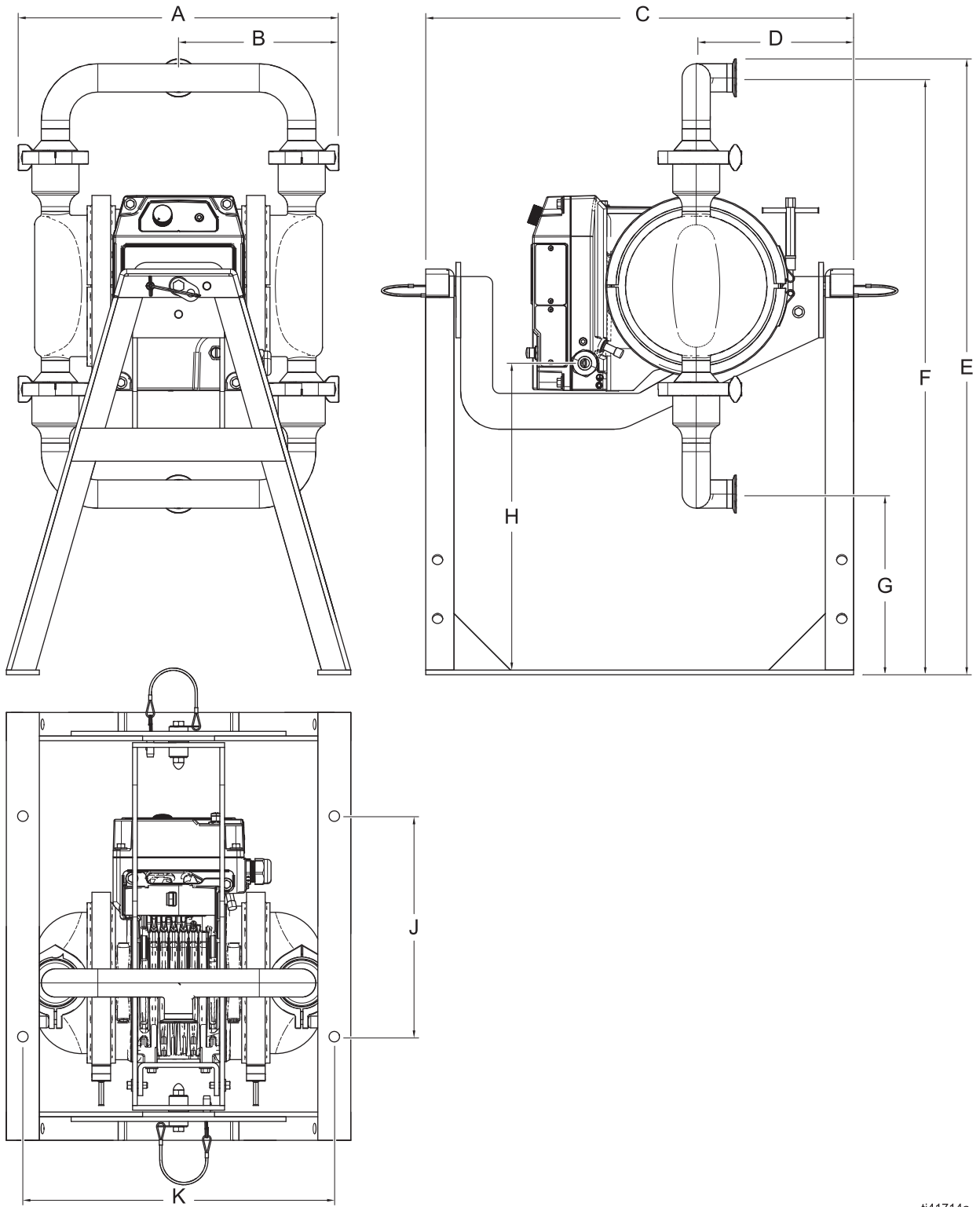

ti41714a

FIG. 28: h80 (QHD) Model Dimensions (HS model shown)

h80 (QHD) Model Dimensions						
Ref.	Wetted Section Material					
	FG		HS, PH, 3A			
	in.	cm	in. (Ball)	in. (Flapper)	cm (Ball)	cm (Flapper)
A	19.50	49.53	17.90	17.90	45.47	45.47
B	---	---	8.95	8.95	22.73	22.73
C	14.17	36.00	22.70	22.70	57.66	57.66
D	5.22	13.26	9.10	9.10	23.11	23.11
E	20.54	52.17	32.68	32.18	83.00	81.74
F	19.28	48.97	31.67	31.17	80.44	79.17
G	2.44	6.20	9.67	10.09	24.56	25.63
H	6.65	16.90	16.53	16.53	41.99	41.99
J	6.00	15.24	11.70	11.70	29.72	29.72
K	7.73	19.63	16.52	16.52	41.96	41.96

Dimensions for h120 (QHE) Ball Models

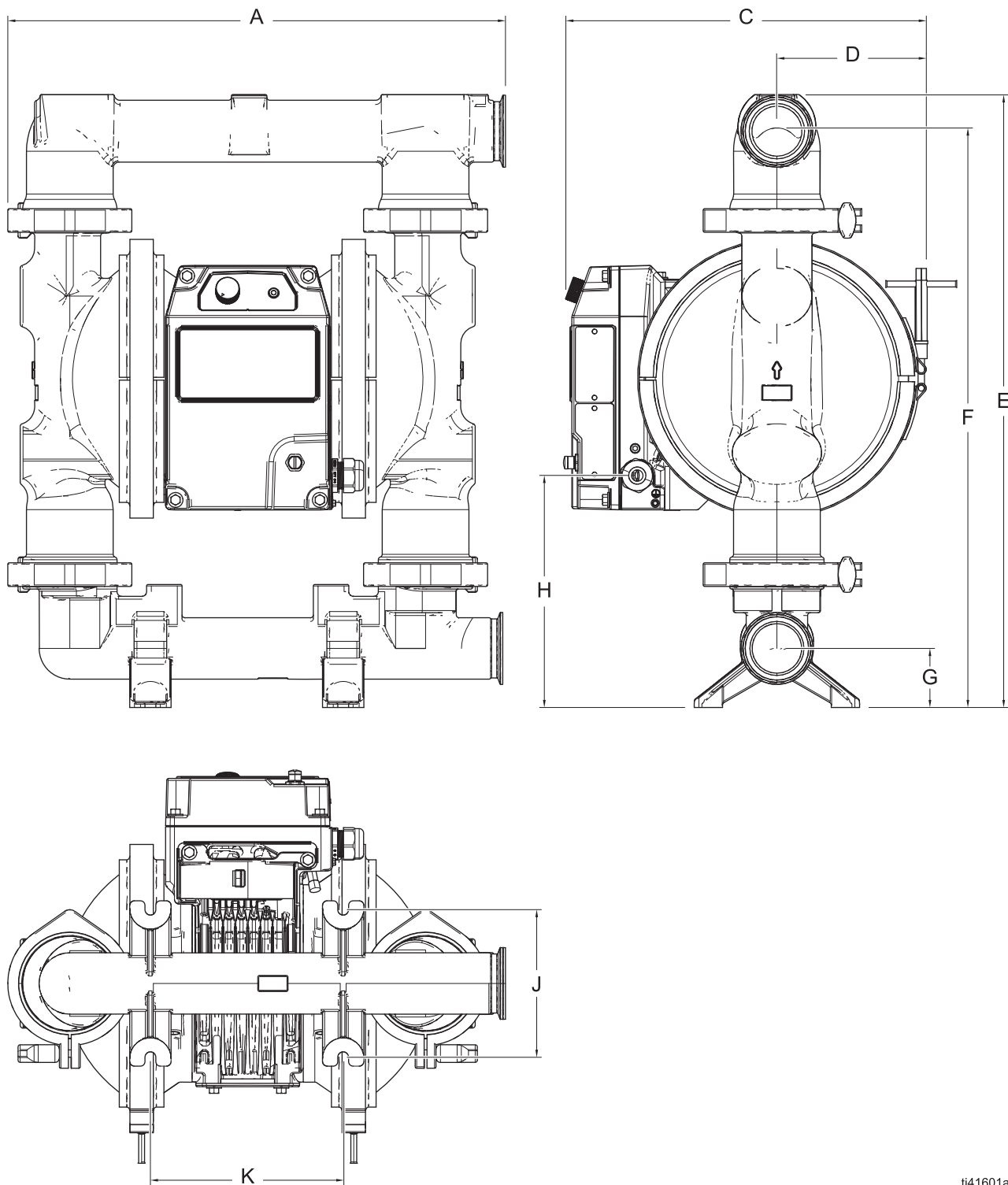

ti41601a

FIG. 29: h120 (QHE) Ball Model Dimensions (FG model shown)

Dimensions

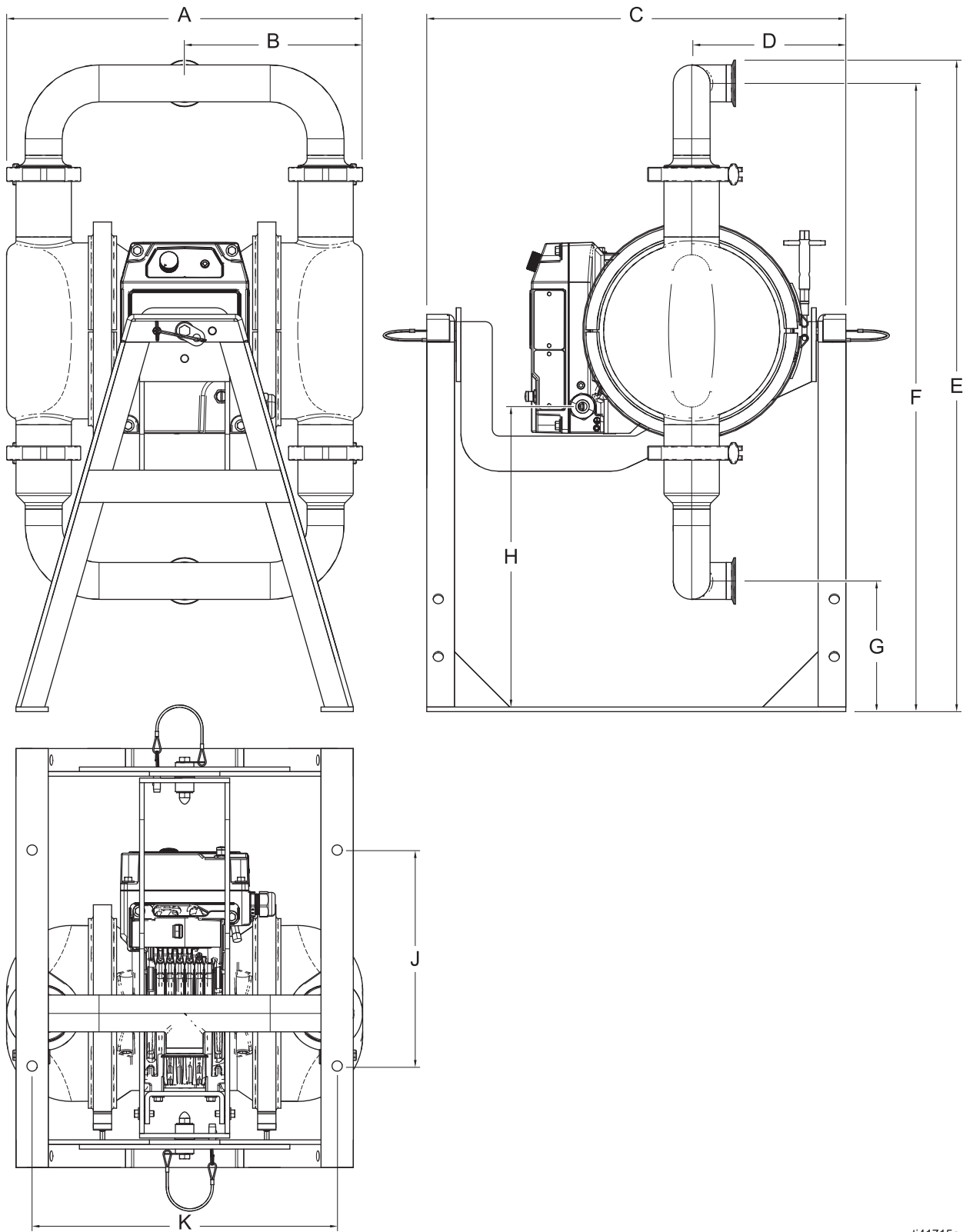

ti41715a

FIG. 30: h120 (QHE Ball and QHF Vertical Flapper) Model Dimensions (HS model shown)

h120 (QHE) Ball Model Dimensions				
Ref.	Wetted Section Material			
	FG		HS, PH, 3A	
	in.	cm	in.	cm
A	22.03	55.96	20.75	52.71
B	---	---	10.37	26.34
C	15.28	38.81	22.70	57.66
D	6.33	16.08	9.10	23.11
E	25.95	65.91	35.31	89.69
F	24.40	61.98	34.05	86.49
G	2.50	6.35	7.09	18.01
H	9.82	24.94	16.53	41.99
J	6.25	15.88	11.70	29.72
K	8.16	20.73	16.52	41.96

Dimensions for h120 (QHF) Flapper Models

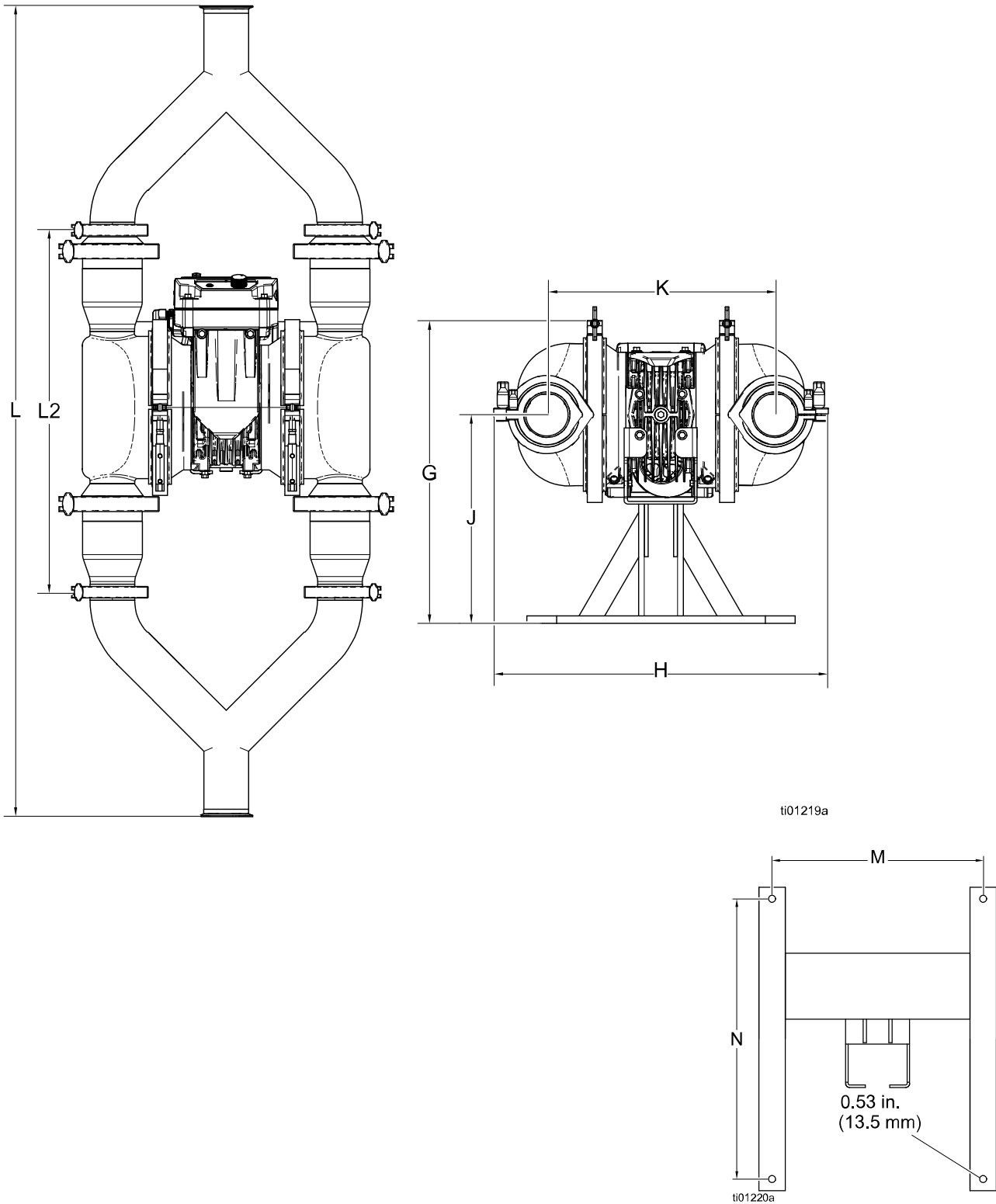

FIG. 31. h120 (QHF) Horizontal Flapper Model Dimensions (SSE model shown)

h120 (QHF) Flapper Model Dimensions				
	Vertical Flapper (SSA and SSB connections), see FIG. 30.		Horizontal Flapper (SSE and SSG connections), see FIG. 31.	
	in.	cm	in.	cm
A	22.4	57.0	---	---
B	11.2	28.5	---	---
C	22.7	57.7	---	---
D	9.1	23.1	---	---
E	38.8	99.0	---	---
F	37.2	94.4	---	---
G	4.1	10.3	19.9	50.5
H	16.5	42.0	22.4	56.9
J	11.7	29.7	14.0	35.6
K	16.5	42.0	15.2	38.6
L	---	---	54.5	138.4
L2	---	---	24.3	61.7
M	---	---	16.0	40.6
N	---	---	21.2	53.8

Technical Specifications

Fluid Temperature Range

NOTICE

Temperature limits are based on mechanical stress only. Certain chemicals will further limit the fluid temperature range. Stay within the temperature range of the most-restricted wetted component. Operating at a fluid temperature that is too high or too low for the components of your pump may cause equipment damage.

NOTE: The maximum fluid temperature for Hazardous units should not exceed 230°F (110°C) or the limitation based on the Wetted Section Materials, whichever is lower.

Material of Wetted Contact Section Parts (Seat, Check, Diaphragm)*	Fluid Temperature Range by Wetted Section Material					
	Metal (AL,FG, HS, PH, SS, 3A)*		Plastic (PV)*		Plastic (AC, PP)*	
	Fahrenheit	Celsius	Fahrenheit	Celsius	Fahrenheit	Celsius
(3A) 3-A Hygienic, Stainless Steel	-60° to 275°	-51° to 135°	10° to 180°	-12° to 82°	32° to 150°	0° to 66°
(AC) Acetal	-20° to 180°	-29° to 82°				
(AL) Aluminum	-60° to 275°	-51° to 135°				
(BN) Buna-N	10° to 180°	-12° to 82°				
(CO) Polychloroprene Overmold	10° to 180°	-12° to 82°				
(CR) Polychloroprene, standard, ball	10° to 180°	-12° to 82°				
(CW) Polychloroprene, weighted, ball	10° to 180°	-12° to 82°				
(EO) EPDM Overmolded	-40° to 250°	-40° to 121°				
(EP) EPDM	-60° to 275°	-51° to 135°				
(FG) Food Grade, Stainless Steel	-60° to 275°	-51° to 135°				
(FK) Fluoroelastomer	-40° to 275°	-40° to 135°				
(FL) Flapper (SS)	-60° to 275°	-51° to 135°				
(GE) Graco Engineered Thermoplastic	-40° to 180°	-40° to 82°				
(HS) Hygienic, Stainless Steel	-60° to 275°	-51° to 135°				
(PH) Pharmaceutical, Stainless Steel	-60° to 275°	-51° to 135°				
(PO) PTFE/EPDM Overmolded	-40° to 180°	-40° to 82°				
(PP) Polypropylene	32° to 175°	0° to 79°	32° to 175°	0° to 79°		
(PS) PTFE/Santo 2-piece	-40° to 180°	-40° to 82°	10° to 180°	-12° to 82°		
(PT) PTFE	-40° to 220°	-40° to 104°				
(PV) PVDF	10° to 225°	-12° to 107°				
(SD) 440c Stainless Steel	-40° to 220°	-40° to 104°				

Material of Wetted Contact Section Parts (Seat, Check, Diaphragm)*	Fluid Temperature Range by Wetted Section Material					
	Metal (AL,FG, HS, PH, SS, 3A)*		Plastic (PV)*		Plastic (AC, PP)*	
	Fahrenheit	Celsius	Fahrenheit	Celsius	Fahrenheit	Celsius
(SO) Santoprene Overmolded	-40° to 180°	-40° to 82°				
(SP) Santoprene	-40° to 180°	-40° to 82°	10° to 180°	-12° to 82°	32° to 150°	0° to 66°
(SS) 316 Stainless Steel	-60° to 275°	-51° to 135°				
(TP) TPE	-20° to 150°	-29° to 66°				

* See Configuration Matrix, starting on page 9, for detailed descriptions.

Technical Specifications for h30 (QHC) Models

QUANTM h30 (QHC) Pumps				
	US		Metric	
Maximum fluid working pressure	100 psi		6.89 bar, 0.69 MPa	
Maximum free-flow delivery	30 gpm		114 lpm	
Maximum size pumpable solids				
High Sanitation models	0.42 in.		10.7 mm	
All other models	0.125 in.		3.2 mm	
Fluid flow*	0.08 gal/cycle		0.30 l/cycle	
Environmental temperature range	-4° to 104°F		-20° to 40°C	
Maximum operating altitude	9842 ft		3000 m	
IP rating, ordinary locations models			IP66	
IP rating, explosive atmospheres or hazardous (classified) locations models			IP66	
Electrical ratings				
	Rated Voltage	Phase	Hertz	Current
h30 (QHC) models, FF1 motor	200–240 V	3	50/60 Hz	7.5 A
h30 (QHC) models, FF2 motor	200–240 V	1	50/60 Hz	10 A
h30 (QHC) models, FF3 motor	200–240 V	3	50/60 Hz	7.5 A
h30 (QHC) models, FF4 motor	200–240 V	1	50/60 Hz	10 A
h30 (QHC) models, FF5 motor	100–120 V	1	50/60 Hz	12 A
h30 (QHC) models, FF6 motor	100–120 V	1	50/60 Hz	12 A
Materials of construction				
See Configuration Matrix , starting on page 9, for materials of construction for your equipment model.				
Fluid inlet/outlet sizes				
Models with wetted section materials coded:				
FG	1.5 in. sanitary tri-clamp or 40 mm DIN 11851			
HS, PH, 3A	1.0 in sanitary tri-clamp or RD52 x 1/6 DIN			
Maximum suction lift*				
Wet	29.0 ft		8.84 m	
Dry	7.9 ft		2.41 m	
Noise (dBa)				
Maximum sound pressure	74 dBa at full power and flow			
<i>Sound pressure measured 1.6 feet (0.5 meter) from equipment.</i>				
Weight				
Models with wetted section materials coded:				
FG	88 lb		39.9 kg	
HS, PH, 3A	77 lb		34.9 kg	
Notes				
* May vary based on pump materials, suction condition, discharge head, pressure, and fluid type.				
All trademarks or registered trademarks are the property of their respective owners.				

Technical Specifications for h80 (QHD) Ball Models

QUANTM h80 (QHD) Ball Pumps				
	US		Metric	
Maximum fluid working pressure	100 psi		6.89 bar, 0.69 MPa	
Maximum free-flow delivery	80 gpm		300 lpm	
Maximum size pumpable solids				
High Sanitation models	0.5 in.		12.7 mm	
All other models	0.19 in.		4.8 mm	
Fluid flow*	0.42 gal/cycle		1.59 l/cycle	
Environmental temperature range	-4° to 104°F		-20° to 40°C	
Maximum operating altitude	9842 ft		3000 m	
IP rating, ordinary locations models			IP66	
IP rating, explosive atmospheres or hazardous (classified) locations models			IP66	
Electrical ratings				
	Rated Voltage	Phase	Hertz	Current
h80 (QHD) models, FF1 motor	200-240 V	3	50/60 Hz	7.5 A
h80 (QHD) models, FF2 motor	200-240 V	1	50/60 Hz	15 A
h80 (QHD) models, FF3 motor	200-240 V	3	50/60 Hz	7.5 A
h80 (QHD) models, FF4 motor	200-240 V	1	50/60 Hz	15 A
Materials of construction				
See Configuration Matrix , starting on page 9, for materials of construction for your equipment model.				
Fluid inlet/outlet sizes				
Models with wetted section materials coded:				
	FG	2.0 in. sanitary tri-clamp or 50 mm DIN 11851		
	HS, PH, 3A	1.5 in. sanitary tri-clamp or 40 mm DIN 11851, male thread		
Maximum suction lift*				
	Wet	18.0 ft	5.49 m	
	Dry	19.3 ft	5.90 m	
Noise (dBa)				
Maximum sound pressure	72 dBa at full power and full flow			
<i>Sound pressure measured 1.6 feet (0.5 meter) from equipment.</i>				
Weight				
Models with wetted section materials coded:				
	FG	120 lb	54.4 kg	
	HS, PH, 3A	98 lb	44.5	
Notes				
* May vary based on pump materials, suction condition, discharge head, pressure, and fluid type.				
All trademarks or registered trademarks are the property of their respective owners.				

Technical Specifications for h80 (QHD) Flapper Models

QUANTM h80 (QHD) Flapper Pumps				
	US		Metric	
Maximum fluid working pressure	100 psi		6.89 bar, 0.69 MPa	
Maximum free-flow delivery	90 gpm		300 lpm	
Maximum size pumpable solids High Sanitation models	1.2 in.		30.5 mm	
Fluid flow*	0.67 gal/cycle		2.54 l/cycle	
Environmental temperature range	-4° to 104°F		-20° to 40°C	
Maximum operating altitude	9842 ft		3000 m	
IP rating, ordinary locations models			IP66	
IP rating, explosive atmospheres or hazardous (classified) locations models			IP66	
Electrical ratings				
	Rated Voltage	Phase	Hertz	Current
h80 (QHD) models, FF1 motor	200–240 V	3	50/60 Hz	7.5 A
h80 (QHD) models, FF2 motor	200–240 V	1	50/60 Hz	15 A
h80 (QHD) models, FF3 motor	200–240 V	3	50/60 Hz	7.5 A
h80 (QHD) models, FF4 motor	200–240 V	1	50/60 Hz	15 A
Materials of construction				
See Configuration Matrix , starting on page 9, for materials of construction for your equipment model.				
Fluid inlet/outlet sizes				
Models with wetted section materials coded:				
	FG	2.0 in. sanitary tri-clamp or 50 mm DIN 11851		
	HS, PH, 3A	1.5 in. sanitary tri-clamp or 40 mm DIN 11851, male thread		
Maximum suction lift*				
	Wet	18.0 ft	5.48 m	
	Dry	14.7 ft	4.48 m	
Noise (dBa)				
Maximum sound pressure	72 dBa at full power and full flow			
<i>Sound pressure measured 1.6 feet (0.5 meter) from equipment.</i>				
Weight				
Models with wetted section materials coded:				
	FG	120 lb	54.4 kg	
	HS, PH, 3A	98 lb	44.5	
Notes				
* May vary based on pump materials, suction condition, discharge head, pressure, and fluid type.				
All trademarks or registered trademarks are the property of their respective owners.				

Technical Specifications for h120 (QHE) Ball Models

QUANTM h120 (QHE) Ball Pumps				
	US		Metric	
Maximum fluid working pressure	60 psi		4.1 bar, 0.41 MPa	
Maximum free-flow delivery	120 gpm		454 lpm	
Maximum size pumpable solids				
High Sanitation models	0.5 in.		12.7 mm	
All other models	0.25 in.		6.4 mm	
Fluid flow*	0.56 gal/cycle		2.12 l/cycle	
Environmental temperature range	-4° to 104°F		-20° to 40°C	
Maximum operating altitude	9842 ft		3000 m	
IP rating, ordinary locations models			IP66	
IP rating, explosive atmospheres or hazardous (classified) locations models			IP66	
Electrical ratings				
	Rated Voltage	Phase	Hertz	Current
h120 (QHE) models, FF1 motor	200-240 V	3	50/60 Hz	7.5 A
h120 (QHE) models, FF2 motor	200-240 V	1	50/60 Hz	15 A
h120 (QHE) models, FF3 motor	200-240 V	3	50/60 Hz	7.5 A
h120 (QHE) models, FF4 motor	200-240 V	1	50/60 Hz	15 A
Materials of construction				
See Configuration Matrix , starting on page 9, for materials of construction for your equipment model.				
Fluid inlet/outlet sizes				
Models with wetted section materials coded:				
	HS, PH, 3A	2 in. sanitary tri-clamp or 50 mm DIN 11851, male threads		
	FG	2.5 in. sanitary tri-clamp or 65 mm DIN 11851		
Maximum suction lift*				
	Wet	18.0 ft	5.48 m	
	Dry	15.9 ft	4.85 m	
Noise (dBa)				
Maximum sound pressure	77 dBa at full power and full flow			
<i>Sound pressure measured 1.6 feet (0.5 meter) from equipment.</i>				
Weight				
Models with wetted section materials coded:				
	FG	170 lb	77.1 kg	
	HS, PH, 3A	143 lb	64.9 kg	
Notes				
* May vary based on pump materials, suction condition, discharge head, pressure, and fluid type.				
All trademarks or registered trademarks are the property of their respective owners.				

Technical Specifications for h120 (QHE) Flapper Models

QUANTM h120 (QHE) Flapper Pumps				
	US		Metric	
Maximum fluid working pressure	60 psi		4.1 bar, 0.41 MPa	
Maximum free-flow delivery	105 gpm		397 lpm	
Maximum size pumpable solids				
High Sanitation models	2.46 in.		62.5 mm	
Fluid flow*	0.91 gal/cycle		3.44 l/cycle	
Environmental temperature range	-4° to 104°F		-20° to 40°C	
Maximum operating altitude	9842 ft		3000 m	
IP rating, ordinary locations models			IP66	
IP rating, explosive atmospheres or hazardous (classified) locations models			IP66	
Electrical ratings				
	Rated Voltage	Phase	Hertz	Current
h120 (QHE) models, FF1 motor	200–240 V	3	50/60 Hz	7.5 A
h120 (QHE) models, FF2 motor	200–240 V	1	50/60 Hz	15 A
h120 (QHE) models, FF3 motor	200–240 V	3	50/60 Hz	7.5 A
h120 (QHE) models, FF4 motor	200–240 V	1	50/60 Hz	15 A
Materials of construction				
See Configuration Matrix , starting on page 9, for materials of construction for your equipment model.				
Fluid inlet/outlet sizes				
Models with wetted section materials coded:				
	HS, PH, 3A	3 in. sanitary tri-clamp or 80 mm DIN 11851, male threads		
	FG	2.5 in. sanitary tri-clamp or 65 mm DIN 11851		
Maximum suction lift*				
	Wet	18.0 ft	5.48 m	
	Dry	12.5 ft	3.81 m	
Noise (dBa)				
Maximum sound pressure	77 dBa at full power and full flow			
<i>Sound pressure measured 1.6 feet (0.5 meter) from equipment.</i>				
Weight				
Models with wetted section materials coded:				
	FG	170 lb	77.1 kg	
	HS, PH, 3A	143 lb	64.9 kg	
Notes				
* May vary based on pump materials, suction condition, discharge head, pressure, and fluid type.				
All trademarks or registered trademarks are the property of their respective owners.				

California Proposition 65

CALIFORNIA RESIDENTS

 **WARNING:** Cancer and reproductive harm – www.P65warnings.ca.gov.

Graco Standard Warranty

Graco warrants all equipment referenced in this document which is manufactured by Graco and bearing its name to be free from defects in material and workmanship on the date of sale to the original purchaser for use. With the exception of any special, extended, or limited warranty published by Graco, Graco will, for a period of twelve months from the date of sale, repair or replace any part of the equipment determined by Graco to be defective. This warranty applies only when the equipment is installed, operated and maintained in accordance with Graco's written recommendations.

This warranty does not cover, and Graco shall not be liable for general wear and tear, or any malfunction, damage or wear caused by faulty installation, misapplication, abrasion, corrosion, inadequate or improper maintenance, negligence, accident, tampering, or substitution of non-Graco component parts. Nor shall Graco be liable for malfunction, damage or wear caused by the incompatibility of Graco equipment with structures, accessories, equipment or materials not supplied by Graco, or the improper design, manufacture, installation, operation or maintenance of structures, accessories, equipment or materials not supplied by Graco.

This warranty is conditioned upon the prepaid return of the equipment claimed to be defective to an authorized Graco distributor for verification of the claimed defect. If the claimed defect is verified, Graco will repair or replace free of charge any defective parts. The equipment will be returned to the original purchaser transportation prepaid. If inspection of the equipment does not disclose any defect in material or workmanship, repairs will be made at a reasonable charge, which charges may include the costs of parts, labor, and transportation.

THIS WARRANTY IS EXCLUSIVE, AND IS IN LIEU OF ANY OTHER WARRANTIES, EXPRESS OR IMPLIED, INCLUDING BUT NOT LIMITED TO WARRANTY OF MERCHANTABILITY OR WARRANTY OF FITNESS FOR A PARTICULAR PURPOSE.

Graco's sole obligation and buyer's sole remedy for any breach of warranty shall be as set forth above. The buyer agrees that no other remedy (including, but not limited to, incidental or consequential damages for lost profits, lost sales, injury to person or property, or any other incidental or consequential loss) shall be available. Any action for breach of warranty must be brought within two (2) years of the date of sale.

GRACO MAKES NO WARRANTY, AND DISCLAIMS ALL IMPLIED WARRANTIES OF MERCHANTABILITY AND FITNESS FOR A PARTICULAR PURPOSE, IN CONNECTION WITH ACCESSORIES, EQUIPMENT, MATERIALS OR COMPONENTS SOLD BUT NOT MANUFACTURED BY GRACO. These items sold, but not manufactured by Graco (such as electric motors, switches, hose, etc.), are subject to the warranty, if any, of their manufacturer. Graco will provide purchaser with reasonable assistance in making any claim for breach of these warranties.

In no event will Graco be liable for indirect, incidental, special or consequential damages resulting from Graco supplying equipment hereunder, or the furnishing, performance, or use of any products or other goods sold hereto, whether due to a breach of contract, breach of warranty, the negligence of Graco, or otherwise.

FOR GRACO CANADA CUSTOMERS

The Parties acknowledge that they have required that the present document, as well as all documents, notices and legal proceedings entered into, given or instituted pursuant hereto or relating directly or indirectly hereto, be drawn up in English. Les parties reconnaissent avoir convenu que la rédaction du présente document sera en Anglais, ainsi que tous documents, avis et procédures judiciaires exécutés, donnés ou intentés, à la suite de ou en rapport, directement ou indirectement, avec les procédures concernées.

Graco Information

For the latest information about Graco products, visit www.graco.com.

For patent information, see www.graco.com/patents.

TO PLACE AN ORDER, contact your Graco distributor or call to identify the nearest distributor.

Phone: 612-623-6921 **or Toll Free:** 1-800-328-0211, **Fax:** 612-378-3505

All written and visual data contained in this document reflects the latest product information available at the time of publication. Graco reserves the right to make changes at any time without notice.

Original instructions. This manual contains English. MM 3A9286

Graco Headquarters: Minneapolis

International Offices: Belgium, China, Japan, Korea

GRACO INC. AND SUBSIDIARIES • P.O. BOX 1441 • MINNEAPOLIS MN 55440-1441 • USA
Copyright 2022, Graco Inc. All Graco manufacturing locations are registered to ISO 9001.

www.graco.com
Revision F, December 2023