

# QUANTM™ Pumps, Hygienic Models

3A9287G

EN

*Electric-operated diaphragm (EODD) pumps with an integral electric drive for fluid transfer applications. Not for use with gasoline. For professional use only.*



## Important Safety Instructions

Read all warnings and instructions in this manual and related manuals before using the equipment. Save these instructions.

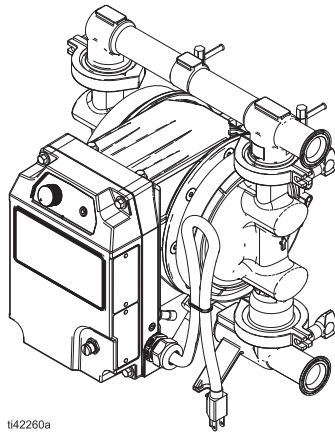

t42260a

**h30 (QHC) Model**

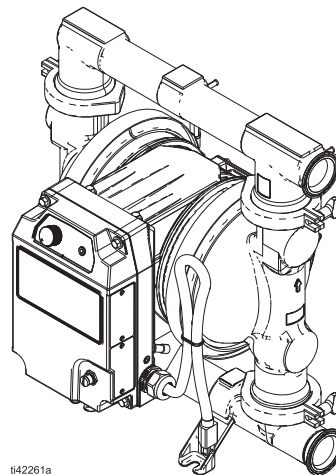

t42261a

**h80 (QHD) Model**

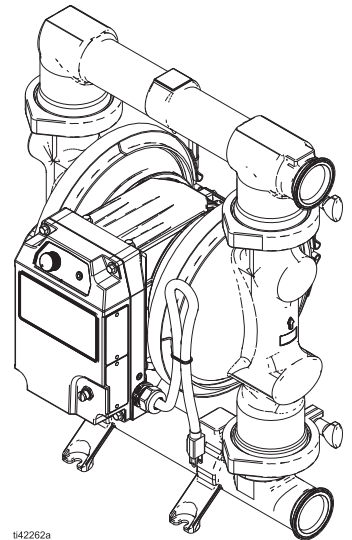

t42262a

**h120 (QHE) Model**

# Contents

<b>Related Manuals</b> .....	<b>2</b>	<b>Checks</b> .....	<b>17</b>
<b>Configuration Matrix</b> .....	<b>3</b>	Check Stops (Ball Models Only) .....	17
<b>Parts</b> .....	<b>5</b>	<b>Manifold Seals</b> .....	<b>18</b>
h30 (QHC) Models .....	5	<b>Fluid Plates</b> .....	<b>19</b>
h80 (QHD) Models .....	7	<b>Diaphragms</b> .....	<b>19</b>
h120 (QHE) Models .....	10	<b>Diaphragm Fasteners</b> .....	<b>20</b>
h120 (QHF) Models .....	12	<b>Stands</b> .....	<b>20</b>
Parts List .....	14	<b>Cart</b> .....	<b>20</b>
<b>Fluid Covers</b> .....	<b>14</b>	<b>Maintenance Bracket Stand</b> .....	<b>20</b>
<b>Manifolds</b> .....	<b>15</b>	<b>Fluid Repair Kits</b> .....	<b>21</b>
Outlet Manifolds .....	15	h30 (QHC) .....	21
Inlet Manifolds .....	15	h80 (QHD) .....	21
<b>Clamps for Fluid Covers</b> .....	<b>16</b>	h120 (QHE) .....	22
<b>Clamps for Manifolds</b> .....	<b>16</b>	h120 (QHF) .....	22
<b>Seats</b> .....	<b>16</b>	<b>Graco Standard Warranty</b> .....	<b>24</b>

## Related Manuals

English Manual Number	Description	Reference
3A7637	QUANTM Electric Motor, Repair-Parts	Motor Manual
3A9286	QUANTM Pumps, Hygienic Models, Instructions	Pump Manual

# Configuration Matrix

Record the model part number and configuration sequence found on your equipment identification plate (ID) to assist you when ordering replacement parts.

**Model Part Number:**

---

**Configuration Sequence:**

---

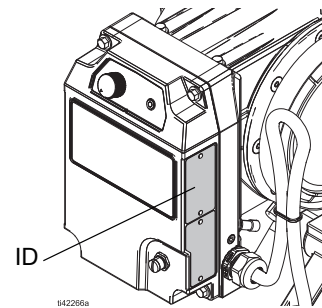

Sample Configuration Sequence: QHC-FGFF1ACACBNBNA10021											
Q	H	C	FG	FF1	AC	AC	BN	BN	A1	00	21
Brand	Application	Model	Wetted Section Material	Motor	Seat Material	Check Material	Diaphragm Material	Manifold Seal Material	Connection	Options	Material Certifications

**NOTE:** Some combinations are not possible. Check with your local distributor.

Brand		Application		Model		Wetted Section Material	
Q	QUANTM	H	Hygienic (h)	C	30 (1 in. port)	FG	Food Grade, Stainless Steel, 125 micro finish (cast CF8M)
				D	80 (1-1/2 in. port)	HS	Hygienic, Stainless Steel, 32 micro finish
				E	120 (2 in. port)	PH	Pharmaceutical, Stainless Steel, 20 micro finish
				F	120 (3 in. port)	3A	3-A Hygienic, Stainless Steel, 32 micro finish

Motor						
	Drive	Coat	Input Voltage	Phase	Location	Cord/Cable Termination
FF1	Aluminum Direct Drive	Fluorinated ethylene propylene (FEP) coat	200–240 V	3-Phase	Hygienic, Ordinary Locations	Cord with plug
FF2	Aluminum Direct Drive	FEP coat	200–240 V	Single-Phase	Hygienic, Ordinary Locations	Cord with plug
FF3	Aluminum Direct Drive	FEP coat	200–240 V	3-Phase	Hygienic, Hazardous (Classified) Locations	Cable with flying leads
FF4	Aluminum Direct Drive	FEP coat	200–240 V	Single-Phase	Hygienic, Explosive Atmospheres	Cable with flying leads
FF5	Aluminum Direct Drive	FEP coat	100–120 V	Single-Phase	Hygienic, Ordinary Locations	Cord with plug
FF6	Aluminum Direct Drive	FEP coat	100–120 V	Single-Phase	Hygienic, Hazardous (Classified) Locations	Cable with flying leads

Configuration Matrix

Seat Material		Check Material		Diaphragm Material		Manifold Seal Material	
<b>FL</b>	Flapper, for hygienic models only	<b>BN</b>	Buna-N, ball	<b>BN</b>	Buna-N	--	None
<b>SS</b>	316 Stainless Steel	<b>CW</b>	Polychloroprene, weighted, ball	<b>EO</b>	EPDM Overmold	<b>BN</b>	Buna-N
		<b>EP</b>	EPDM, ball	<b>FK</b>	Fluoroelastomer	<b>EP</b>	EPDM
		<b>FK</b>	Fluoroelastomer, ball	<b>PO</b>	PTFE/EPDM Overmold	<b>FK</b>	Fluoroelastomer
		<b>FL</b>	Flapper, Stainless Steel	<b>PS</b>	PTFE/Santoprene, two-piece	<b>PT</b>	PTFE
		<b>PT</b>	PTFE, ball	<b>SP</b>	Santoprene		
		<b>SP</b>	Santoprene, ball				

Connection		Options		Material Certifications	
<b>S13</b>	Stainless Steel, standard ports, hygienic clamp	<b>00</b>	Standard	<b>21</b>	EN 10204 type 2.1
<b>S14</b>	Stainless Steel, standard ports, DIN	<b>SF</b>	Sanitary Flapper	<b>31</b>	EN 10204 type 3.1
<b>SSA</b>	Center-ported tri-clamp				
<b>SSB</b>	Center-ported DIN				
<b>SSE</b>	Horizontal Wye Manifold Tri-Clamp				
<b>SSG</b>	Horizontal No Manifold				

Motor Drive Selection			
Hygienic - North America			
Model	Ordinary Location (NEMA Plug)	Hazardous Location (Flying Leads)	Voltage range/phase count
h30 (QHC)	FF1, FF5	FF3, FF6	200/240V/3-Phase 100/120V/Single-Phase
h80 (QHD)	FF1	FF3	200/240V/3-Phase
h120 (QHE/QHF)	FF1	FF3	200/240V/3-Phase
Hygienic - International			
Model	Ordinary Location (IEC Plug)	Hazardous Location (Flying Leads)	Voltage range/phase count
h30 (QHC)	FF2	FF4	200/240V/Single-Phase
h80 (QHD)	FF2	FF4	200/240V/Single-Phase
h120 (QHE/QHF)	FF2	FF4	200/240V/Single-Phase

# Parts

## h30 (QHC) Models

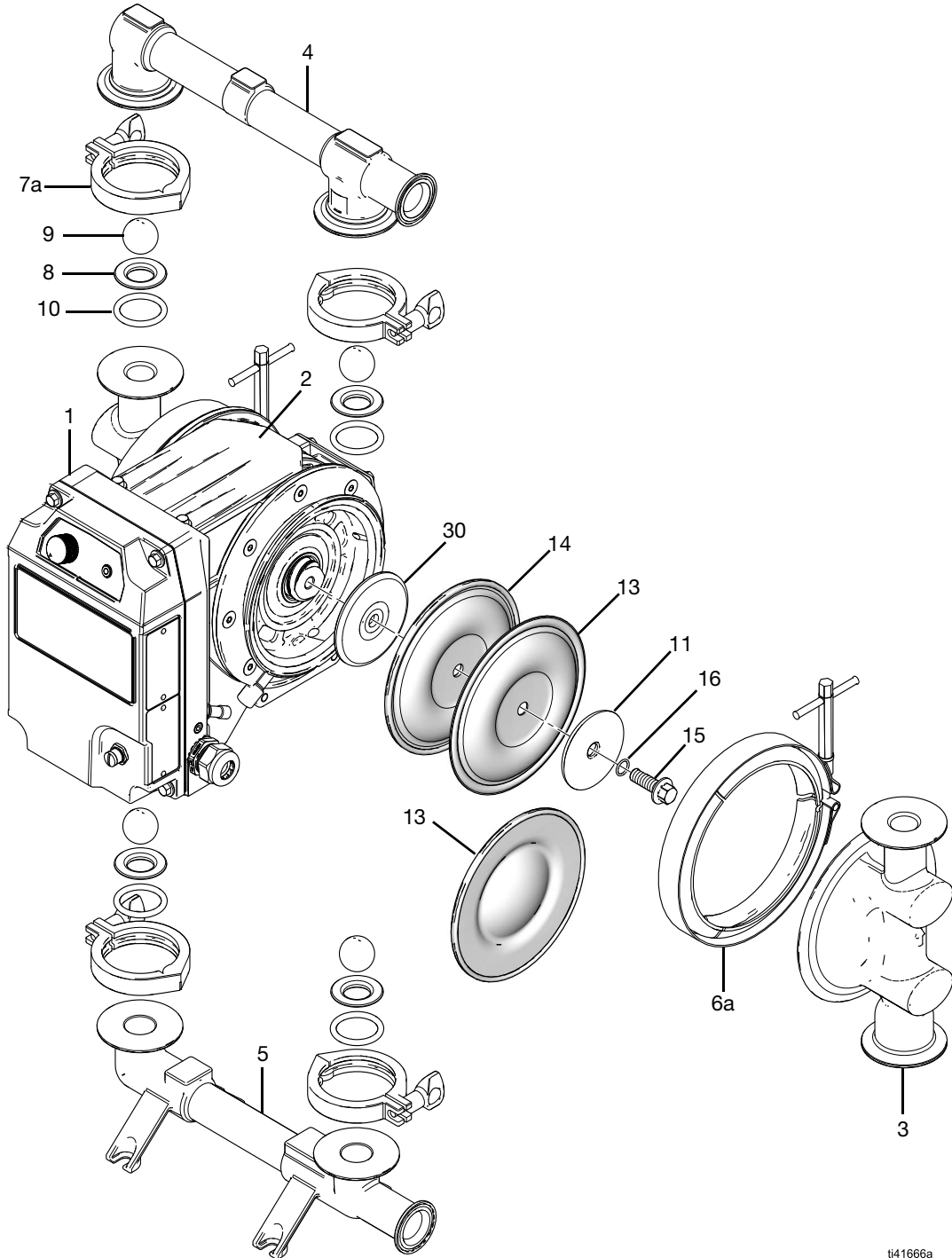

t41666a

h30 (QHC) Food Grade (FG) model shown

Parts

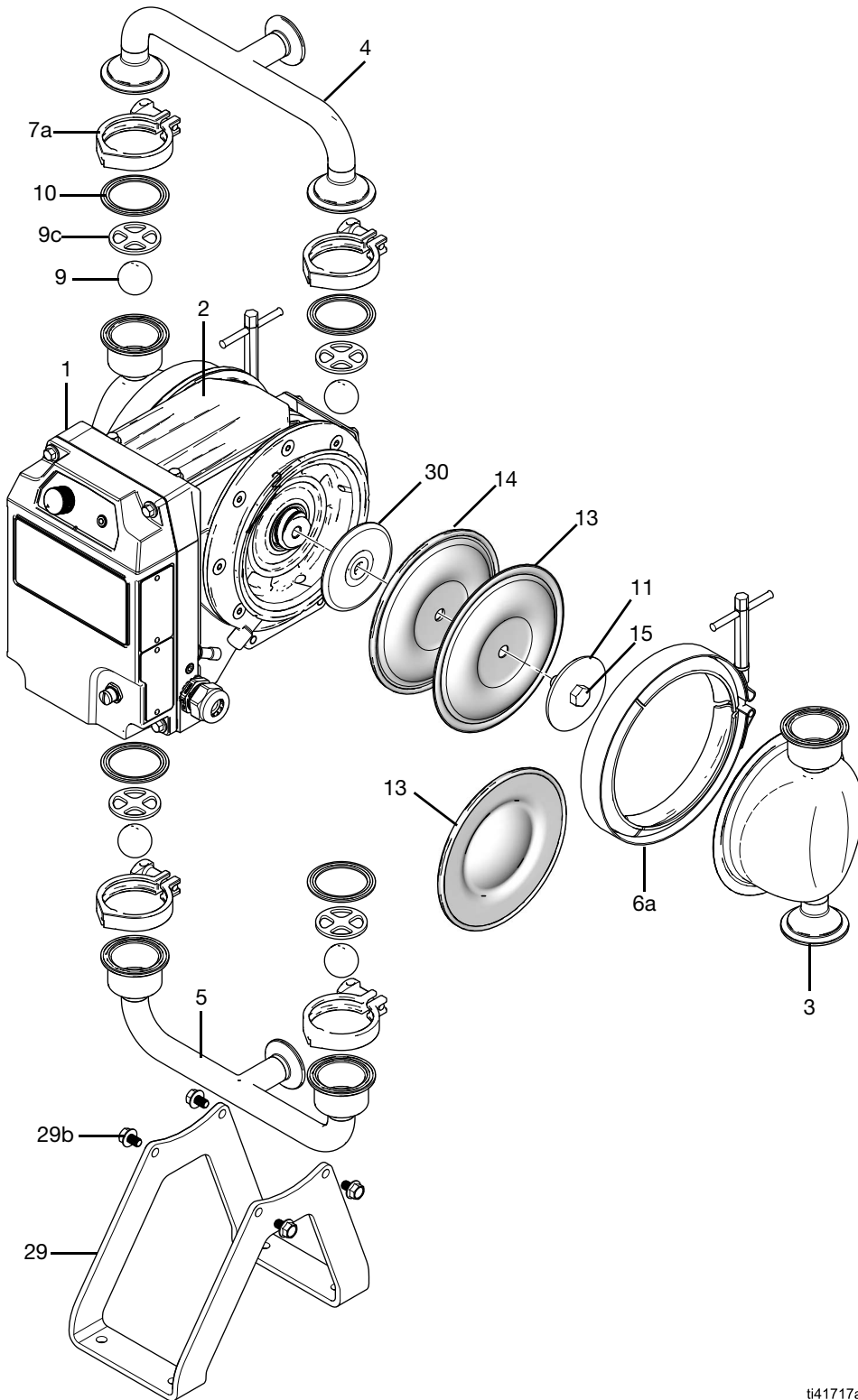

t41717a

h30 (QHC) High Sanitation (HS, PH, 3A) model shown 7

# h80 (QHD) Models

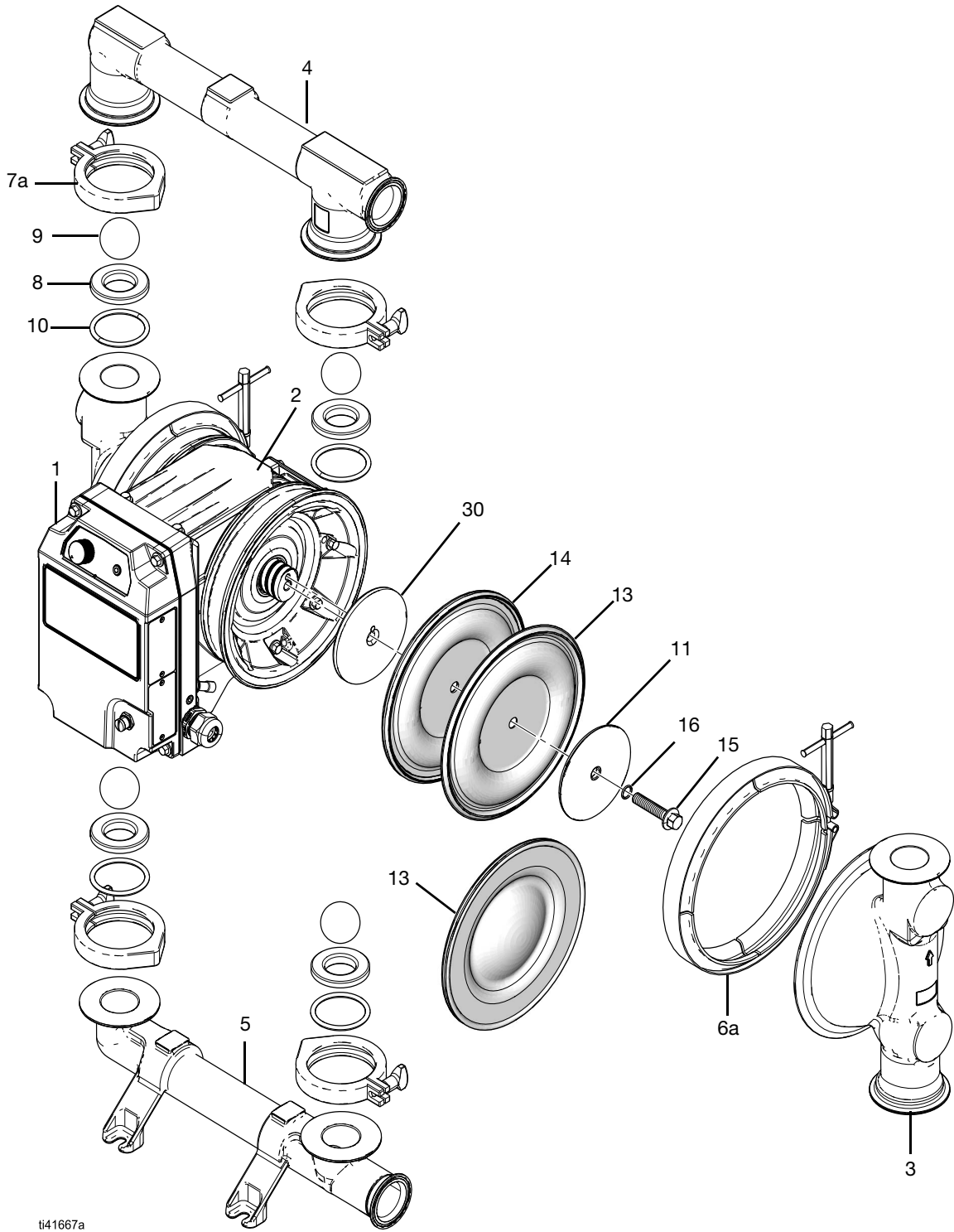

ti41667a

h80 (QHD) Food Grade (FG) model shown

Parts

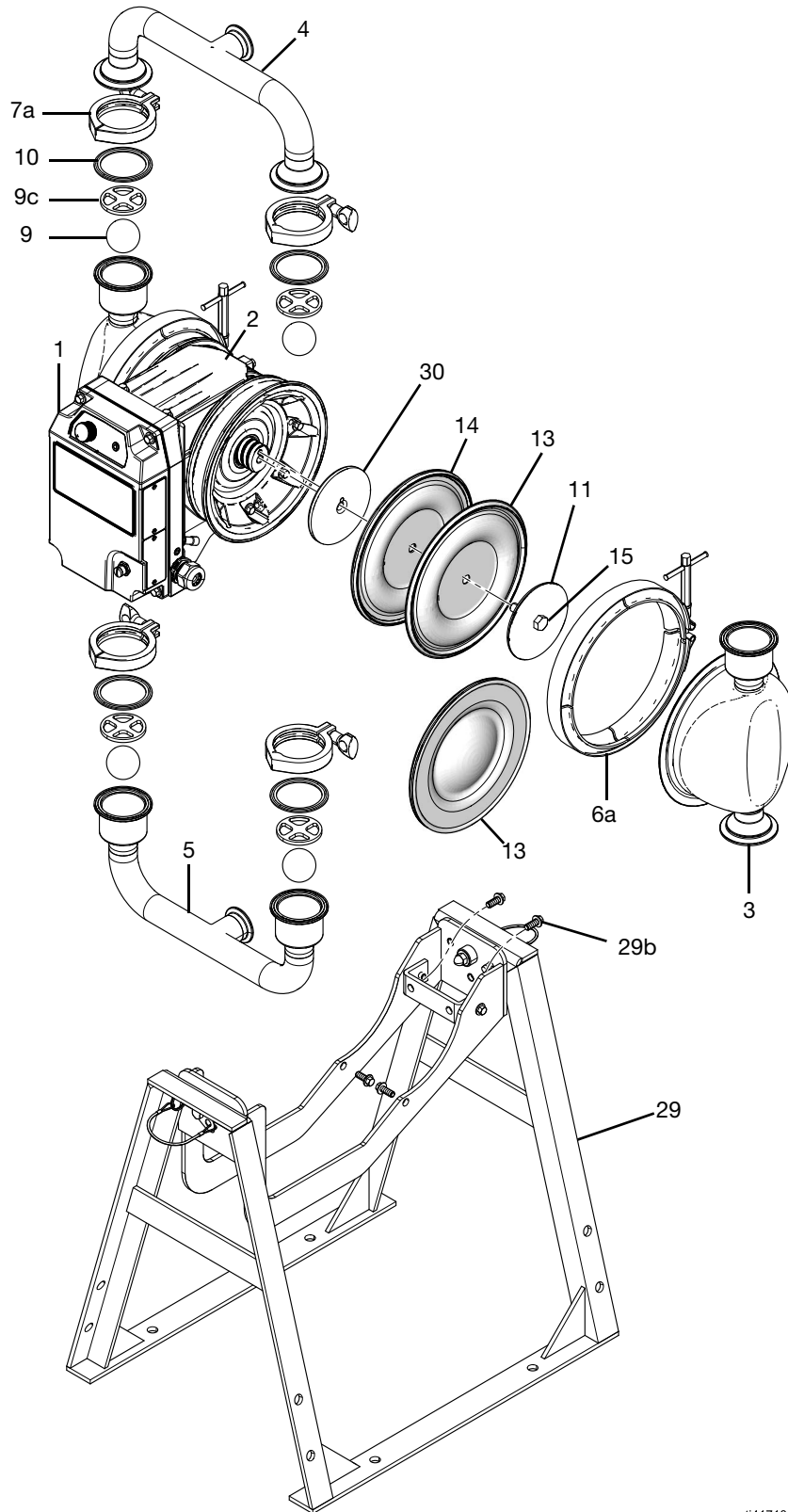

t41718a

h80 (QHD) High Sanitation (HS, PH, 3A) Ball model shown





# h120 (QHE) Models

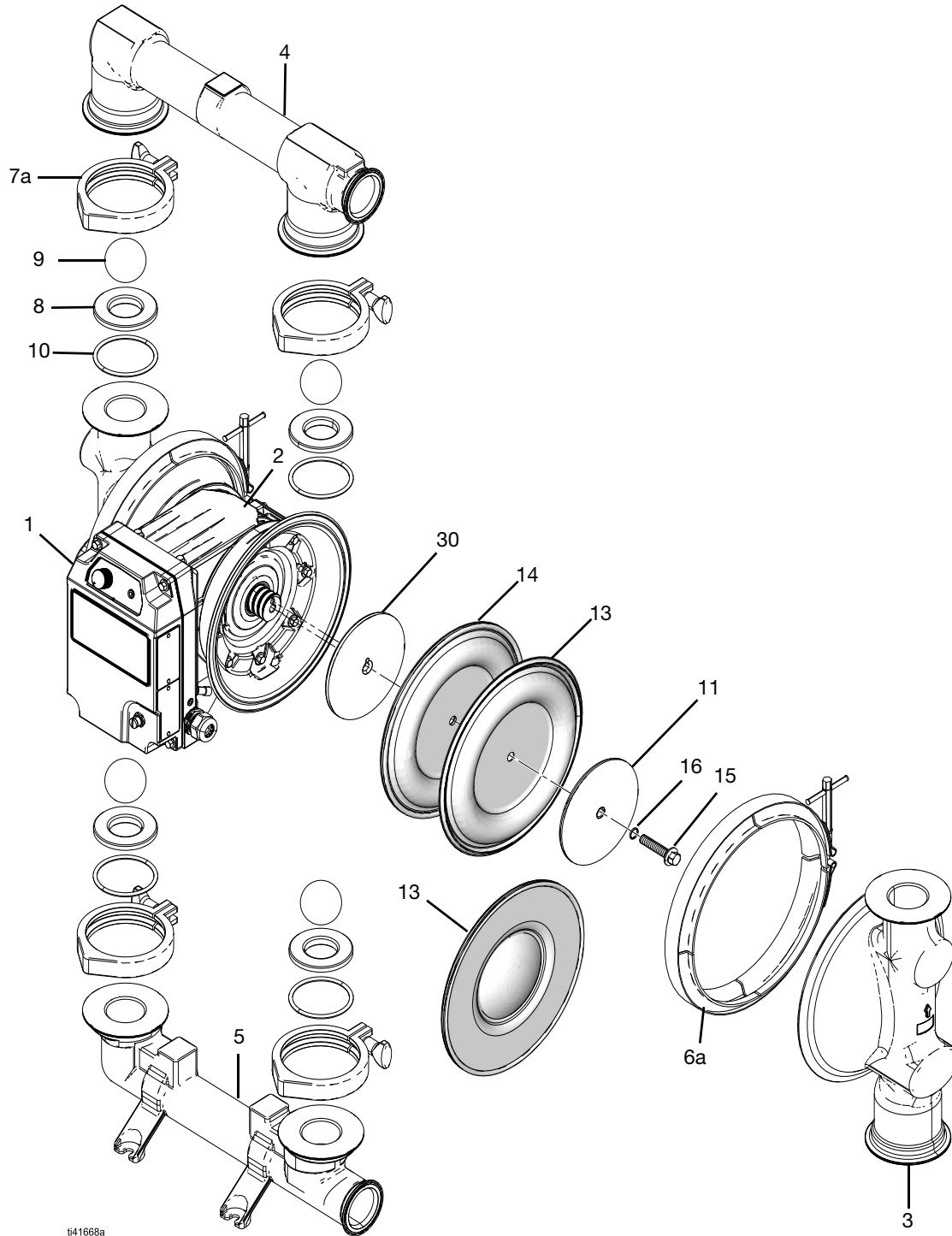

h120 (QHE) Food Grade (FG) model shown

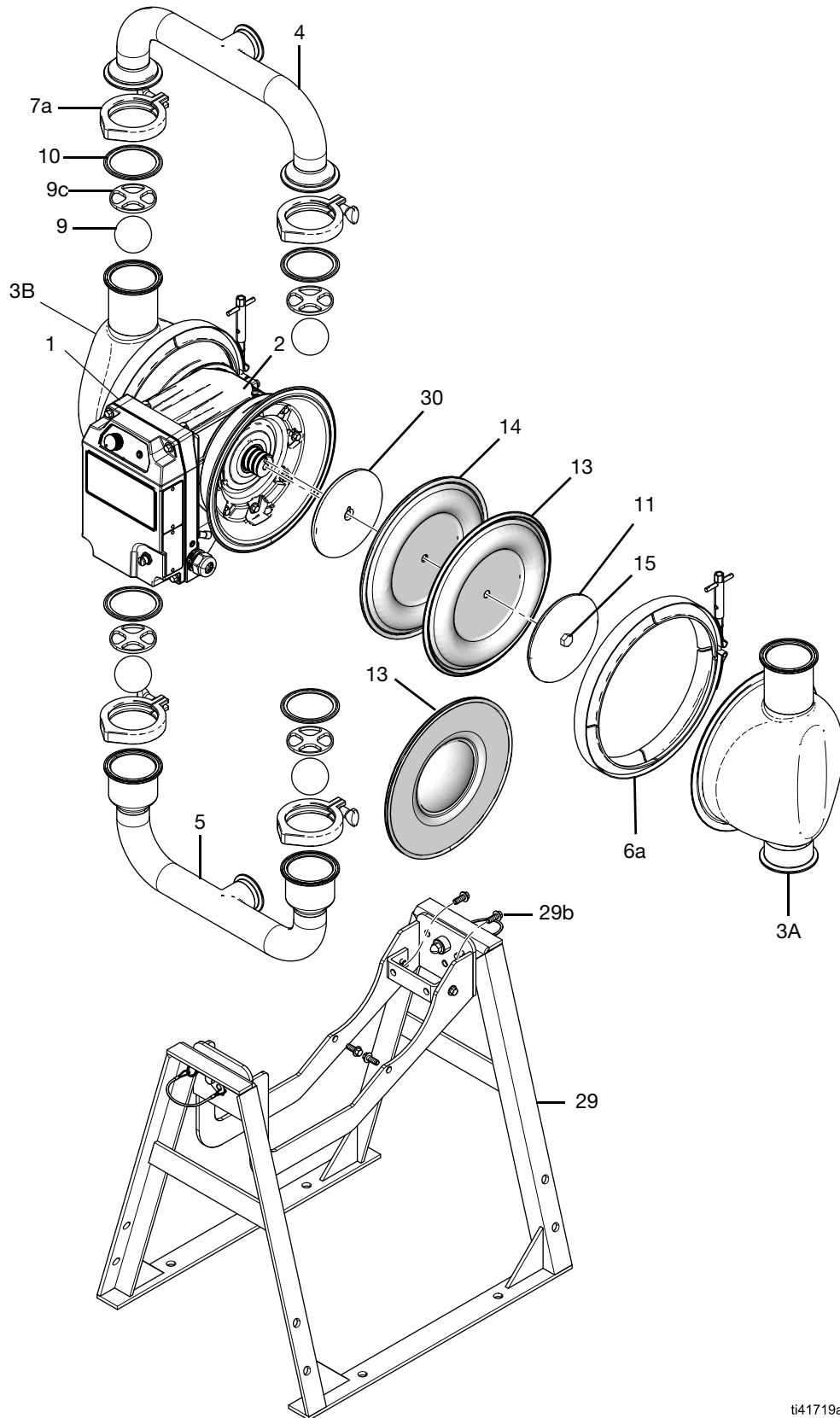

ti41719a

h120 (QHE) High Sanitation (HS, PH, 3A) model shown

# h120 (QHF) Models

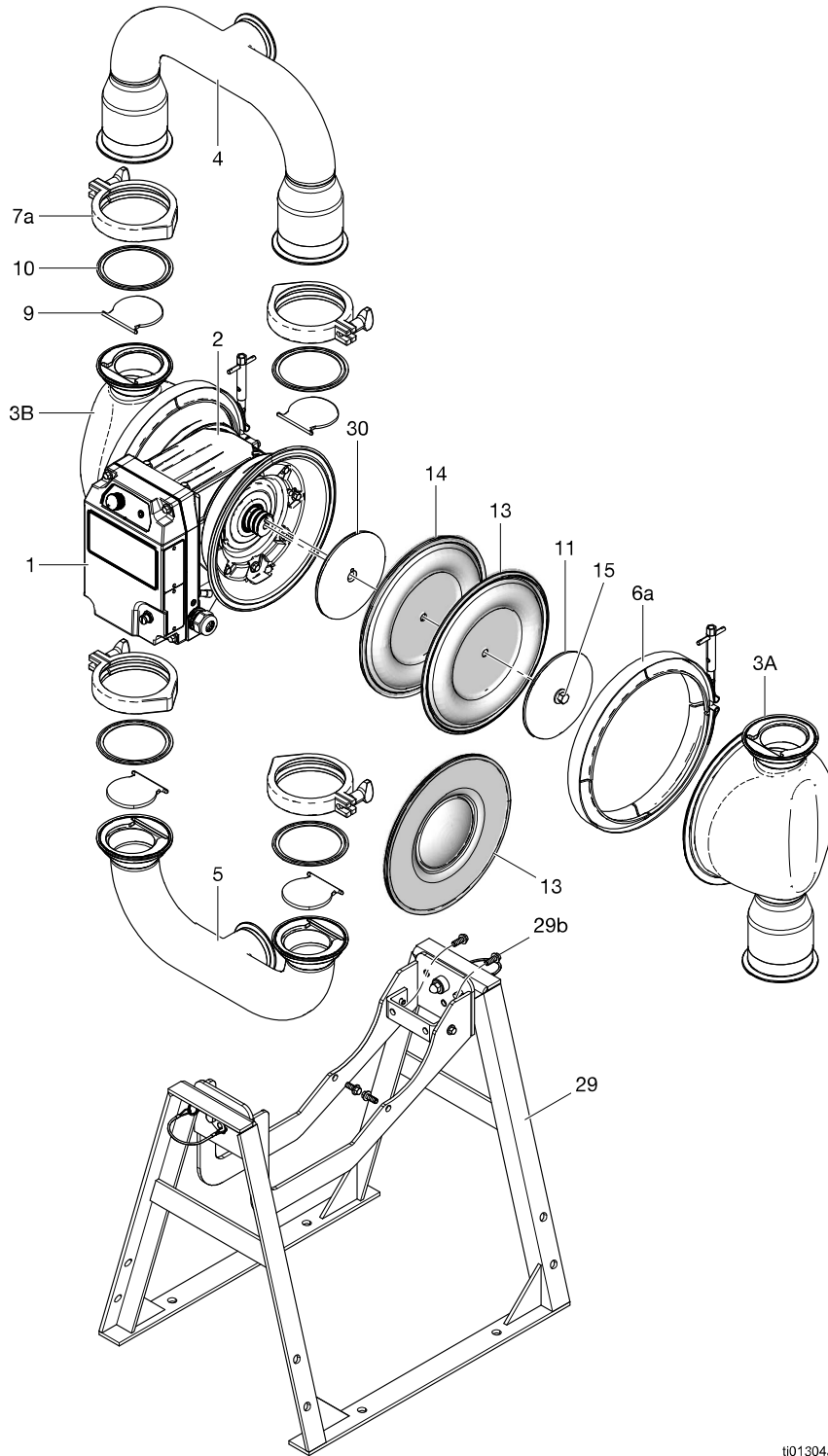

ti01304a

h120 (QHF) High Sanitation (HS) Vertical Flapper model shown (SSA/SSB)

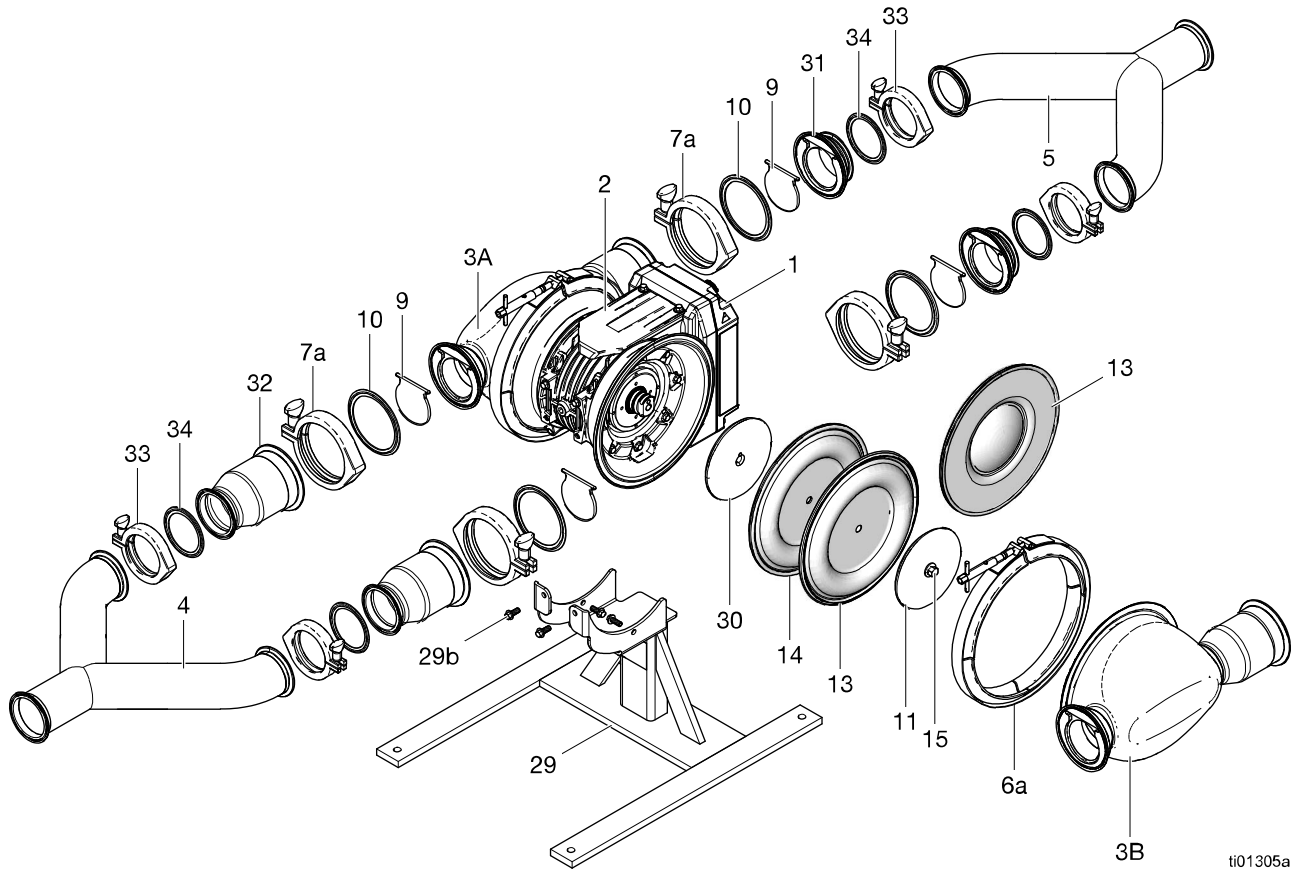

ti01305a

h120 (QHF) High Sanitation (HS) Horizontal Flapper model shown (SSE/SSG)

## Parts List

Parts are sold individually unless otherwise indicated.

Ref.	Part	Description	Qty.
1†	---	MODULE, motor	1
2		MODULE, stator shield	1
	25V114	for FG models	
	25V115	for HS, PH, and 3A models	
3A, 3B	---	COVER, fluid; see page 14	1 each
4	---	MANIFOLD, outlet; see page 15	1
4b†	---	PLUG, outlet manifold; supplied with Ref. 4	0 or 1
5	---	MANIFOLD, inlet; see page 15	1
5b†	---	PLUG, inlet manifold; supplied with Ref. 5	0 or 1
6a†	---	CLAMP, fluid cover; see page 16	0 or 2
7a†	---	CLAMP, manifold; see page 16	0 or 4
8	---	SEAT, ball or flapper; see page 24	4
9	---	CHECK, ball or flapper; see page 24	4
9c†	---	STOP, ball; for select models only; not shown; see page 17	0 or 4
10†	---	SEAL, packing, manifold; see page 18	0 or 4 or 8
11	---	PLATE, diaphragm, fluid side; see page 19	2
13	---	DIAPHRAGM	2
14†	---	DIAPHRAGM, backer	0 or 2
15	---	FASTENER; see page 20	2
16†	---	SEAL, packing; see page 24	0 or 2
29†	---	STAND, frame, assembly; for select models only; includes Ref. 29b; see page 20	0 or 1
29b†	---	FASTENER, stand, assembly; for select models only; included with Ref. 29	0 or 1
30		PLATE, diaphragm, air side	2
	16D326	for h30 (QHC) models	
	2003133	for h80 (QHD) flapper models	
	19D142	for h80 (QHD) models	
	2001442	for h120 (QHF) flapper models	
	19D143	for h120 (QHE)	

Additional parts for horizontal flapper pumps (i120 (QTF) SSE/SSG:

Ref.	Part	Description	Qty.
31	25P084	SEAT, inlet	2
32	25P082	CHAMBER, outlet	2
10, 34	25P065	GASKET, pkg of 4 & 4	0 or 8
33	15D475	CLAMPS, manifold	0 or 4
34	25P063	GASKET, pkg of 4	0 or 4

--- Not available separately or part number varies.

† Not included in all models.

‡ See your motor manual for specific motor models. See **Related Manuals**, page 2.

\* Part not included in model.

**NOTE:** Replacement safety labels, tags, and cards are available at no cost.

## Fluid Covers

Fluid Covers					
Ref.	Wetted Section Material	Part	Part		
			h30 (QHC)	h80 (QHD)	h120 (QHE/F)
3A	Metal	<b>FG</b>	277262	277263	277264 (QHE)
		<b>HS</b>	25N995	17Z576 25N997 <i>(for HS models with FL checks)</i>	25E575 (QHE) 25E576 (QHF)
			<b>PH</b>	25P040	25P041
		<b>3A</b>	---	17Z576	25E575 (QHE)
3B	Metal	<b>FG</b>	277262	277263	277264 (QHE)
		<b>HS</b>	25N995	17Z576 25N997(FL)	25E575 (QHE) 25E577 (QHF)
			<b>PH</b>	25P040	25P041
		<b>3A</b>	---	17Z576	25E575 (QHE)

# Manifolds

## Outlet Manifolds

Outlet Manifolds							
Ref.	Wetted Section Material	Connection	Check	Part			
				h30 (QHC)	h80 (QHD)	h120 (QHE)	h120 (QHF)
4	FG	S13	Ball	277266	277268	277270	---
		S14	Ball	24U581	24U583	24U585	---
	HS	SSA	Ball	25P019	25P021	25E578	---
			FL (Flapper)	---	25P023	---	25E579
		SSB	Ball	19B035	19B037	19B031	---
			FL (Flapper)	---	19B041	---	19B028
	PH	SSA	Ball	17Z575	25P049	25P053	---
		SSB	Ball	---	---	---	---
	3A	SSA	Ball	---	25P021	25E578	---
		SSB	Ball	---	19B037	19B031	---

## Inlet Manifolds

Inlet Manifolds							
Ref.	Wetted Section Material	Connection	Check	Part			
				h30 (QHC)	h80 (QHD)	h120 (QHE)	h120 (QHF)
5	FG	S13	Ball	277265	277267	277269	---
		S14	Ball	24U580	24U582	24U584	---
	HS	SSA	Ball	25P018	25P020	25E580	---
			FL (Flapper)	---	25P022	---	25E581
		SSB	Ball	19B034	19B036	19B030	---
			FL (Flapper)	---	19B040	---	19B029
	PH	SSA	Ball	25P044	25P048	25P052	---
		SSB	Ball	---	---	---	---
	3A	SSA	Ball	---	25P020	25E580	---
		SSB	Ball	---	19B036	19B030	---

## Clamps for Fluid Covers

Clamps for Fluid Covers								
Ref.	Wetted Section Material		h30 (QHC)		h80 (QHD)		h120 (QHE)	
			Part	Qty.	Part	Qty.	Part	Qty.
6a	Metal	<b>FG</b>	18F507	2	15G699	2	26C048	2
		<b>HS</b>	18F507	2	15H341	2	25P107	2
		<b>PH</b>	18F507	2	15H341	2	25P107	2
		<b>3A</b>	---	0	15H341	2	25P107	2

## Clamps for Manifolds

Clamps for Manifolds										
Ref.	Wetted Section Material		h30 (QHC)		h80 (QHD)		h120 (QHE)		h120 (QHF)	
			Part	Qty.	Part	Qty.	Part	Qty.	Part	Qty.
7a	Metal	<b>FG</b>	620223	4	15D475	4	510490	4	---	---
		<b>HS</b>	500984	4	620223	4	15D475	4	510490	4
		<b>PH</b>	500984	4	620223	4	15D475	4	---	---
		<b>3A</b>	---	0	620223	4	15D475	4	---	---

## Seats

Seats					
Ref.	Wetted Section Material	Seat Material	Part		
			h30 (QHC)	h80 (QHD)	h120 (QHE)
8	<b>FG</b>	<b>SS</b>	25A276♦	26B430♦	26C568♦
	<b>HS*</b>	---	---	---	---
	<b>PH*</b>	---	---	---	---
	<b>3A*</b>	---	---	---	---

\* Seat (8) included with the manifold (4, 5) or fluid cover (3).

♦ Item is a kit.

### Kits include:

- 4 seats (8)



# Checks

Checks						
Ref.	Check Material	Part	Part			
			h30 (QHC)	h80 (QHD)	h120 (QHE)	h120 (QHF)
9	Plastic	<b>BN</b>	D07070♦	D0B070♦	D0F070♦	---
		<b>EP</b>	26B165♦	25R607♦	26B350♦	---
		<b>FK</b>	D07080♦	D0B080♦	D0F080♦	-----
		<b>PT</b>	D07010♦	D0B010♦	D0F010♦	---
		<b>SP</b>	D07060♦	D0B060♦	D0F060♦	---
	Metal	<b>FL</b>	---	25P088♦	---	25E582♦
	Plastic and Metal	<b>CW</b>	25A299♦	26B431♦	D0F0H0♦	---

♦ *Item is a kit.*

**Kits include:**

- 4 checks (9)

## Check Stops (Ball Models Only)

Check Stops					
Ref.	Wetted Section Material	Part	Part		
			h30 (QHC)	h80 (QHD)	h120 (QHE)
9c	<b>FG</b>		---	---	---
	<b>HS</b>		25P089♦	25P100♦	25E584♦
	<b>PH</b>		25P089♦	25P100♦	25E584♦
	<b>3A</b>		25P089♦	25P100♦	25E584♦

♦ *Item is a kit.*

**Kits include:**

- 4 check stops (9c)

# Manifold Seals

Manifold Seals						
Ref.	Manifold Seal Material	Wetted Section Material	Part			
			h30 (QHC)	h80 (QHD)	h120 (QHE)	h120 (QHF)
10	BN	FG	25V081♦	---	---	---
		HS	25R600♦	25R601♦	25R602♦	25R603♦
		PH	25R600♦	25R601♦	25R602♦	---
		3A	25R600♦	25R601♦	25R602♦	---
	EP	FG	26B689♦	---	26B355♦	---
		HS	25P060♦	25P061♦	25P063♦	25P064♦
		PH	25P060♦	25P061♦	25P063♦	---
		3A	25P060♦	25P061♦	25P063♦	---
	FK	FG	26A890♦	---	26B356♦	---
		HS	26A890♦	26A891♦	26A892♦	26A893♦
		PH	26A890♦	26A891♦	26A892♦	---
		3A	26A890♦	26A891♦	26A892♦	---
	PT	FG	26B690♦	26B255♦	26B354♦	---
		HS	---	26A914†♦	---	26A916†♦
		PH	---	26A914†♦	---	---
		3A	---	26A914†♦	---	---

♦ Item is a kit.

† PTFE/EPDM bonded.

**Kits include:**

- 4 or 8 seals (10), as applicable

## Fluid Plates

Fluid Plates				
Ref.	Wetted Section Material	h30 (QHC)	h80 (QHD)	h120 (QHE, QHF)
11	<b>FG</b>	15C039	189309	189299
	<b>HS</b>	25P117	15K288	189299
	<b>PH</b>	25P117	15K288	189299
	<b>3A</b>	---	15K288	189299

## Diaphragms

Diaphragms					
Ref.	Diaphragm Material	Wetted Section Material	Part		
			h30 (QHC)	h80 (QHD)	h120 (QHE, QHF)
13, 14	<b>BN</b>	<b>FG</b>	25V216♦	25V200♦	25V207♦
		<b>HS</b>			
		<b>PH</b>			
		<b>3A</b>	---		
	<b>EO</b>	<b>FG</b>	---	25V228♦	25V215♦
		<b>HS</b>	---		
		<b>PH</b>	---		
		<b>3A</b>	---		
	<b>FK</b>	<b>FG</b>	25V217♦	25V201♦	25V208♦
		<b>HS</b>			
		<b>PH</b>			
		<b>3A</b>	---		
	<b>PO</b>	<b>FG</b>	25V219♦	25V205♦	25V214♦
		<b>HS</b>			
		<b>PH</b>			
		<b>3A</b>	---		
	<b>PS</b>	<b>FG</b>	25P131♦	25P207♦	25P266♦
		<b>HS</b>			
		<b>PH</b>			
		<b>3A</b>	---	---	---
<b>SP</b>	<b>FG</b>	25V218♦	25V203♦	25V209♦	
	<b>HS</b>				
	<b>PH</b>				
	<b>3A</b>	---			

♦ *Item is a kit.*

Kits include:

- 2 diaphragms (13)
- 2 diaphragm backers (14, if applicable)
- 2 seals (16, if applicable)
- 1 packet anaerobic adhesive

# Diaphragm Fasteners

Diaphragm Fasteners			
Ref.	Part		
	h30	h80	h120
15	189044	189410	189410

# Stands

Stands						
Ref.	Wetted Section Material	Part				
		h30 (QHC) 1-inch ports	h80 (QHD) 2-inch ports	h120 (QHE) 2- & 3-inch ports	h120 (QHF) 2- & 3-inch ports Vertical (SSA/SSB)	h120 (QHF) 2- & 3-inch ports Horizontal (SSE/SSG)
29	FG	---	25U279	25U279	---	---
	HS	19C461	---	25U279	25U279	25V102
	PH	19C461	---	25U279	---	---
	3A	19C461	---	25U279	---	---

# Cart

Carts			
Ref.	Part		
	h30 (QHC)	h80 (QHD)	h120 (QHE)
	25U599	25U599	25U599 HS, PH, 3A

# Maintenance Bracket Stand

Maintenance Bracket Stand		
Ref.	Part	Description
31	18F978	STAND, Maintenance Bracket

# Fluid Repair Kits

See **Configuration Matrix** on page 3 for definitions of the seat, check, diaphragm, and seals materials.

As applicable, all Fluid Repair Kits include:

- 4 seats
- 4-8 manifold gaskets
- 4 checks
- 2 diaphragms
- 2 diaphragm backers
- 2 diaphragm bolts
- 2 diaphragm bolt O-rings
- 1 adhesive

## h30 (QHC)

h30 (QHC)	
Part	Seat, Check, Diaphragm, Seals Materials
<b>Wetted Section: FG</b>	
25V230	SS,CW,PO,PT
25V231	SS,CW,PO,EP
25V232	SS,CW,PS,EP
25V233	SS,CW,PS,PT
25V234	SS,CW,SP,PT
25V235	SS,CW,SP,EP
25V236	SS,FK,FK,FK
25V237	SS,PT,PO,PT
25V238	SS,PT,PO,EP
25V239	SS,PT,PS,PT
25V240	SS,PT,PS,EP
25V242	SS,SP,SP,PT
25V243	SS,SP,SP,EP
25V244	SS,BN,BN,BN
<b>Wetted Section: HS, PH, 3A</b>	
25V246	--,CW,PO,EP
25V247	--,CW,PS,EP
25V250	--,CW,SP,EP
25V251	--,FK,FK,FK
25V253	--,PT,PO,EP

h30 (QHC)	
Part	Seat, Check, Diaphragm, Seals Materials
25V255	--,PT,PS,EP
25V257	--,SP,SP,EP
25V258	--,BN,BN,BN

## h80 (QHD)

h80 (QHD)	
Part	Seat, Check, Diaphragm, Seals Materials
<b>Wetted Section: FG</b>	
25V323	SS,CW,PO,PT
25V324	SS,CW,PS,PT
25V325	SS,CW,SP,PT
25V326	SS,CW,SP,EP
25V327	SS,FK,FK,FK
25V328	SS,PT,PO,PT
25V329	SS,PT,PS,PT
25V330	SS,SP,SP,EP
25V331	SS,BN,BN,EP
25V332	SS,EP,EO,EP
25V333	SS,PT,EO,EP
25V334	SS,CW,EO,EP
<b>Wetted Section: HS, PH, 3A</b>	
25V335	--,CW,PO,EP
25V336	--,CW,PS,EP
25V337	--,CW,SP,EP
25V338	--,FK,FK,FK
25V339	--,PT,PO,EP
25V340	--,PT,PS,EP
25V341	--,SP,SP,EP
25V342	--,BN,BN,BN
25V343	--,EP,EO,EP

h80 (QHD)	
Part	Seat, Check, Diaphragm, Seals Materials
25V344	--,PT,EO,EP
25V345	--,CW,EO,EP
25V346	FL,--,PO,EP
25V347	FL,--,PS,EP
25V348	FL,--,SP,EP
25V349	FL,--,FK,FK

## h120 (QHE)

h120 (QHE)	
Part	Seat, Check, Diaphragm, Seals Materials
<b>Wetted Section: FG</b>	
25V375	SS,CW,PO,PT
25V376	SS,CW,PS,PT
25V377	SS,CW,SP,PT
25V378	SS,CW,SP,EP
25V379	SS,FK,FK,FK
25V380	SS,PT,PO,PT
25V381	SS,PT,PS,PT
25V382	SS,SP,SP,EP
25V383	SS,BN,BN,EP
25V384	SS,EP,EO,EP
25V385	SS,PT,EO,EP
25V386	SS,CW,EO,EP
<b>Wetted Section: HS, PH, 3A</b>	
25V387	--,CW,PO,EP
25V388	--,CW,PS,EP
25V389	--,CW,SP,EP
25V390	--,FK,FK,FK
25V391	--,PT,PO,EP
25V392	--,PT,PS,EP
25V394	--,SP,SP,EP
25V395	--,BN,BN,BN

h120 (QHE)	
Part	Seat, Check, Diaphragm, Seals Materials
25V396	--,EP,EO,EP
25V397	--,PT,EO,EP
25V399	--,CW,EO,EP

## h120 (QHF)

h120 (QHF)	
Part	Seat, Check, Diaphragm, Seals Materials
<b>Wetted Section: HS</b>	
2002683	FL, --, PO, EP
2002693	FL, --, PS, EP
2002694	FL, --, SP, EP
2002695	FL, --, FK, EP
2002696	FL, --, BN, EP



# Graco Standard Warranty

Graco warrants all equipment referenced in this document which is manufactured by Graco and bearing its name to be free from defects in material and workmanship on the date of sale to the original purchaser for use. With the exception of any special, extended, or limited warranty published by Graco, Graco will, for a period of twelve months from the date of sale, repair or replace any part of the equipment determined by Graco to be defective. This warranty applies only when the equipment is installed, operated and maintained in accordance with Graco's written recommendations.

This warranty does not cover, and Graco shall not be liable for general wear and tear, or any malfunction, damage or wear caused by faulty installation, misapplication, abrasion, corrosion, inadequate or improper maintenance, negligence, accident, tampering, or substitution of non-Graco component parts. Nor shall Graco be liable for malfunction, damage or wear caused by the incompatibility of Graco equipment with structures, accessories, equipment or materials not supplied by Graco, or the improper design, manufacture, installation, operation or maintenance of structures, accessories, equipment or materials not supplied by Graco.

This warranty is conditioned upon the prepaid return of the equipment claimed to be defective to an authorized Graco distributor for verification of the claimed defect. If the claimed defect is verified, Graco will repair or replace free of charge any defective parts. The equipment will be returned to the original purchaser transportation prepaid. If inspection of the equipment does not disclose any defect in material or workmanship, repairs will be made at a reasonable charge, which charges may include the costs of parts, labor, and transportation.

**THIS WARRANTY IS EXCLUSIVE, AND IS IN LIEU OF ANY OTHER WARRANTIES, EXPRESS OR IMPLIED, INCLUDING BUT NOT LIMITED TO WARRANTY OF MERCHANTABILITY OR WARRANTY OF FITNESS FOR A PARTICULAR PURPOSE.**

Graco's sole obligation and buyer's sole remedy for any breach of warranty shall be as set forth above. The buyer agrees that no other remedy (including, but not limited to, incidental or consequential damages for lost profits, lost sales, injury to person or property, or any other incidental or consequential loss) shall be available. Any action for breach of warranty must be brought within two (2) years of the date of sale.

**GRACO MAKES NO WARRANTY, AND DISCLAIMS ALL IMPLIED WARRANTIES OF MERCHANTABILITY AND FITNESS FOR A PARTICULAR PURPOSE, IN CONNECTION WITH ACCESSORIES, EQUIPMENT, MATERIALS OR COMPONENTS SOLD BUT NOT MANUFACTURED BY GRACO.** These items sold, but not manufactured by Graco (such as electric motors, switches, hose, etc.), are subject to the warranty, if any, of their manufacturer. Graco will provide purchaser with reasonable assistance in making any claim for breach of these warranties.

In no event will Graco be liable for indirect, incidental, special or consequential damages resulting from Graco supplying equipment hereunder, or the furnishing, performance, or use of any products or other goods sold hereto, whether due to a breach of contract, breach of warranty, the negligence of Graco, or otherwise.

## FOR GRACO CANADA CUSTOMERS

The Parties acknowledge that they have required that the present document, as well as all documents, notices and legal proceedings entered into, given or instituted pursuant hereto or relating directly or indirectly hereto, be drawn up in English. Les parties reconnaissent avoir convenu que la rédaction du présente document sera en Anglais, ainsi que tous documents, avis et procédures judiciaires exécutés, donnés ou intentés, à la suite de ou en rapport, directement ou indirectement, avec les procédures concernées.

## Graco Information

For the latest information about Graco products, visit [www.graco.com](http://www.graco.com).

For patent information, see [www.graco.com/patents](http://www.graco.com/patents).

**TO PLACE AN ORDER**, contact your Graco distributor or call to identify the nearest distributor.

**Phone:** 612-623-6921 **or Toll Free:** 1-800-328-0211, **Fax:** 612-378-3505

*All written and visual data contained in this document reflects the latest product information available at the time of publication. Graco reserves the right to make changes at any time without notice.*

Original instructions. This manual contains English. MM 3A9287

**Graco Headquarters:** Minneapolis

**International Offices:** Belgium, China, Japan, Korea

**GRACO INC. AND SUBSIDIARIES • P.O. BOX 1441 • MINNEAPOLIS MN 55440-1441 • USA**  
**Copyright 2022, Graco Inc. All Graco manufacturing locations are registered to ISO 9001.**

[www.graco.com](http://www.graco.com)  
Revision G, December 2023