

CARBON STEEL

## Check-Mate™ 800 Pumps

308351N

EN

With Priming Piston and Severe-Duty Rod and Cylinder

Refer to page 2 for Table of Contents.



### Important Safety Instructions

Read all warnings and instructions in this manual.  
Save these instructions. See page 2 for model numbers and maximum working pressures.

*Models 198466  
and 246938*

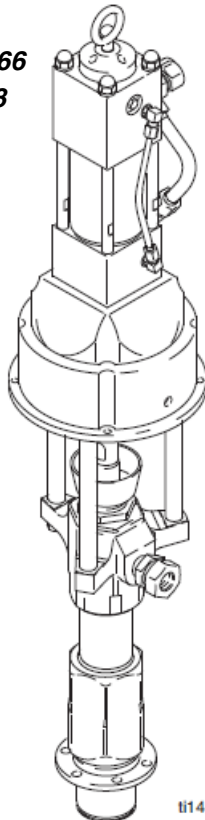

ti1447a

*Models  
237265, 246940  
and 246941*

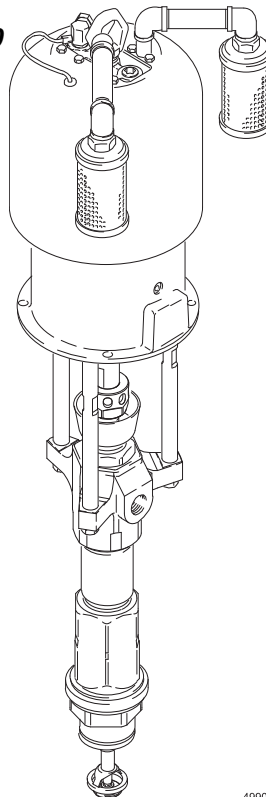

4990c

*Models 236471  
and 246942*

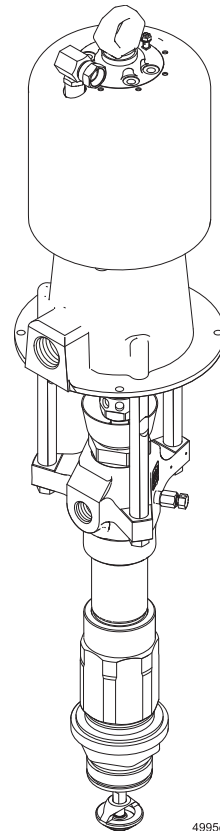

4995c

# Table of Contents

List of Models .....	2	Reconnecting the Displacement Pump .....	19
Symbols .....	3	Displacement Pump Service .....	20
Warnings .....	3	Parts .....	28
Installation .....	6	Technical Data and Performance Chart .....	38
Operation/Maintenance .....	12	Dimensions .....	49
Service		Mounting Hole Layout .....	49
Troubleshooting .....	17	Graco Standard Warranty .....	50
Required Tools .....	18	Graco Information .....	50
Disconnecting the Displacement Pump .....	18		

## List of Models

Part No.	Series	Pump Model	Ratio	Maximum Fluid Working Pressure	Maximum Air (or Hydraulic*) Input Pressure
236471	B	King™	65:1	40 MPa, 403 bar (5850 psi)	0.6 MPa, 6 bar (90 psi)
237265	B	Reduced Icing Quiet King™	65:1	40 MPa, 403 bar (5850 psi)	0.6 MPa, 6 bar (90 psi)
240945	B	Quiet King™	65:1	40 MPa, 403 bar (5850 psi)	0.6 MPa, 6 bar (90 psi)
253376	C	Quiet King™	65:1	40 MPa, 403 bar (5850 psi)	0.6 MPa, 6 bar (90 psi)
237261	A	Bulldog®	31:1	21 MPa, 214 bar (3100 psi)	0.7 MPa, 7 bar (100 psi)
241901	A	Bulldog® (55 Gallon/200 Liter Size)	31:1	21 MPa, 214 bar (3100 psi)	0.7 MPa, 7 bar (100 psi)
237274	A	Reduced Icing Quiet Bulldog®	31:1	21 MPa, 214 bar (3100 psi)	0.7 MPa, 7 bar (100 psi)
237264	A	Senator®	19:1	15 MPa, 157 bar (2280 psi)	0.8 MPa, 8.4 bar (120 psi)
198475	A	Quiet King™	65:1	40 MPa, 403 bar (5850 psi)	0.6 MPa, 6 bar (90 psi)
198466	A	Viscount® II		40 MPa, 403 bar (5850 psi)	10.3 MPa*, 103 bar* (1500 psi*)
246942	B	King™	65:1	48 MPa, 483 bar (7000 psi)	0.7 MPa, 7 bar (100 psi)
246940	B	Bulldog®	31:1	21 MPa, 214 bar (3100 psi)	0.7 MPa, 7 bar (100 psi)
246941	B	Senator®	19:1	15 MPa, 157 bar (2280 psi)	0.8 MPa, 8.4 bar (120 psi)
246938	B	Viscount® II		40 MPa, 403 bar (5850 psi)	10.3 MPa*, 103 bar* (1500 psi*)

# Symbols

## Warning Symbol



This symbol alerts you to the possibility of serious injury or death if you do not follow the instructions.

## Caution Symbol



This symbol alerts you to the possibility of damage to or destruction of equipment if you do not follow the instructions.



INSTRUCTIONS

### EQUIPMENT MISUSE HAZARD

Equipment misuse can cause the equipment to rupture or malfunction and result in serious injury.

- This equipment is for professional use only.
- Read all instruction manuals, tags, and labels before operating the equipment.
- Use the equipment only for its intended purpose. If you are not sure, call your Graco distributor.
- Do not alter or modify this equipment.
- Check equipment daily. Repair or replace worn or damaged parts immediately.
- Do not exceed the maximum working pressure stated on the equipment or in the **Technical Data** for your equipment. Do not exceed the maximum working pressure of the lowest rated component in your system.
- Use fluids and solvents which are compatible with the equipment wetted parts. Refer to the **Technical Data** section of all equipment manuals. Read the fluid and solvent manufacturer's warnings.
- Do not use hoses to pull equipment.
- Route hoses away from traffic areas, sharp edges, moving parts, and hot surfaces. Do not expose Graco hoses to temperatures above 82°C (180°F) or below -40°C (-40°F).
- Wear hearing protection when operating this equipment.
- Do not lift pressurized equipment.
- Comply with all applicable local, state, and national fire, electrical, and safety regulations.



# WARNING



## SKIN INJECTION HAZARD

Spray from the spray gun/dispense valve, leaks or ruptured components can inject fluid into your body and cause extremely serious injury, including the need for amputation. Fluid splashed in the eyes or on the skin can also cause serious injury.



- Fluid injected into the skin might look like just a cut, but it is a serious injury. **Get immediate surgical treatment.**
- Do not point the gun/valve at anyone or at any part of the body.
- Do not put your hand or fingers over the spray tip/nozzle.
- Do not stop or deflect leaks with your hand, body, glove or rag.
- Do not “blow back” fluid; this is not an air spray system.
- Always have the tip guard and the trigger guard on the gun when spraying.
- Check the gun diffuser operation weekly. Refer to the gun manual.
- Be sure the gun/valve trigger safety operates before spraying.
- Lock the gun/valve trigger safety when you stop spraying.
- Follow the **Pressure Relief Procedure** on page 12 if the spray tip/nozzle clogs and before cleaning, checking or servicing the equipment.
- Tighten all fluid connections before operating the equipment.
- Check the hoses, tubes, and couplings daily. Replace worn or damaged parts immediately. Do not repair high pressure couplings; you must replace the entire hose.
- Fluid hoses must have spring guards on both ends, to help protect them from rupture caused by kinks or bends near the couplings.



## MOVING PARTS HAZARD

Moving parts, such as the priming piston, can pinch or amputate your fingers.

- Keep clear of all moving parts when starting or operating the pump.
- Before servicing the equipment, follow the **Pressure Relief Procedure** on page 12 to prevent the equipment from starting unexpectedly.



# WARNING



## FIRE AND EXPLOSION HAZARD

Improper grounding, poor ventilation, open flames or sparks can cause a hazardous condition and result in a fire or explosion and serious injury.



- Ground the equipment and the object being sprayed. Refer to **Grounding** on page 6.
- If there is any static sparking or you feel an electric shock while using this equipment, **stop spraying dispensing immediately**. Do not use the equipment until you identify and correct the problem.
- Provide fresh air ventilation to avoid the buildup of flammable fumes from solvents or the fluid being sprayed/dispensed.
- Keep the spray/dispense area free of debris, including solvent, rags, and gasoline.
- Electrically disconnect all equipment in the spray/dispense area.
- Extinguish all open flames or pilot lights in the spray/dispense area.
- Do not smoke in the spray/dispense area.
- Do not turn on or off any light switch in the spray/dispense area while operating or if fumes are present.
- Do not operate a gasoline engine in the spray/dispense area.



## TOXIC FLUID HAZARD

Hazardous fluid or toxic fumes can cause serious injury or death if splashed in the eyes or on the skin, inhaled, or swallowed.

- Know the specific hazards of the fluid you are using.
- Store hazardous fluid in an approved container. Dispose of hazardous fluid according to all local, state and national guidelines.
- Always wear protective eyewear, gloves, clothing and respirator as recommended by the fluid and solvent manufacturer.

# Installation

## Grounding

 **WARNING**



**FIRE AND EXPLOSION HAZARD**  
Before operating the pump, ground the system as explained below. Also read the section **FIRE AND EXPLOSION HAZARD** on page 5.

1. *King Pumps:* use a ground wire and clamp. See Fig. 1. Remove the ground screw (Z) and insert through eye of ring terminal at the end of ground wire (Y). Fasten ground screw back onto pump and tighten securely. Connect the other end of the wire to a true earth ground. Order Part No. 222011 Ground Wire and Clamp.

*All other Pumps:* use a ground wire and clamp. See Fig. 2. Loosen the grounding lug locknut (W) and washer (X). Insert one end of a 1.5 mm<sup>2</sup> (12 ga) minimum ground wire (Y) into the slot in lug (Z) and tighten the locknut securely. Connect the other end of the wire to a true earth ground.

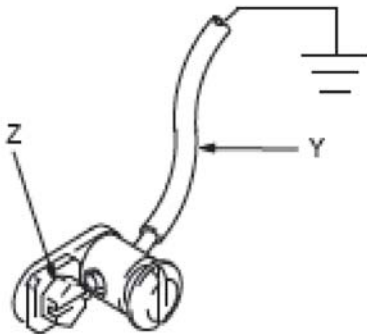

Fig. 1

TH052

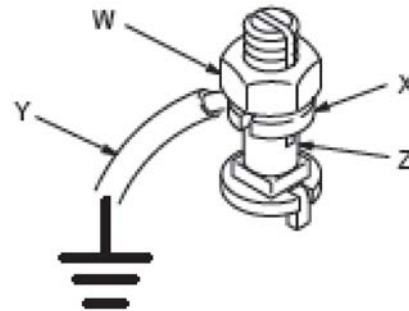

Fig. 2

0554

2. *Air and fluid hoses:* use only electrically conductive hoses.
3. *Air compressor:* follow manufacturer's recommendations.
4. *Spray gun/dispense valve:* ground through connection to a properly grounded fluid hose and pump.
5. *Fluid supply container:* follow your local code.
6. *Object being sprayed:* follow your local code.
7. *All solvent pails used when flushing:* follow your local code. Use only metal pails, which are conductive, placed on a grounded surface. Do not place the pail on a nonconductive surface, such as paper or cardboard, which interrupts the grounding continuity.
8. *To maintain grounding continuity when flushing or relieving pressure,* always hold a metal part of the gun/valve firmly to the side of a grounded *metal* pail, then trigger the gun/valve.

# Installation

## All Systems

**NOTE:** Reference numbers and letters in parentheses in the text refer to the callouts in the figures and parts drawings.

The Typical Installations shown in Figs. 3 and 4 are only guides for selecting and installing system components and accessories. Contact your Graco distributor for assistance in designing a system to suit your particular needs.

Accessories are available from Graco. If you supply your own accessories, be sure they are adequately sized and pressure-rated to meet the system's requirements.

## System Accessories

### Air and Fluid Hoses

Be sure all air hoses and fluid hoses are properly sized and pressure-rated for your system. Use only electrically conductive hoses. Fluid hoses must have spring guards on both ends.

### Mounting Accessories (Except 198466, 198475 and 246938)

Mount the pump (A) to suit the type of installation planned. Fig. 3 on page 8 illustrates a ram-mounted pump in a multi-gun header system. Pump dimensions and the mounting hole layout are shown on page 49.

If you are mounting the pump on a ram, refer to the separate ram manual for installation and operation instructions. Mounting Kit 222776 is available to mount the pump on a 55 gallon (200 liter) ram.

# Installation (Air-Powered Pumps)

## KEY

- |  |   |
|--|---|
| <b>A</b> Pump  | <b>M</b> Fluid Drain Valve (required)                                     |
| <b>B</b> 200 Liter (55 Gallon) Air-Powered Ram             | <b>N</b> Electrically Conductive Fluid Supply Hose                        |
| <b>C</b> Main Air Bleed Valve (required, for pump and ram) | <b>P</b> Fluid Shutoff Valve  |
| <b>D</b> Air Line Lubricator (position only)               | <b>R</b> Gun/Valve Swivel   |
| <b>E</b> Pump Air Bleed Valve (required, for pump)         | <b>S</b> Airless Spray Gun or Dispensing Valve                            |
| <b>F</b> Pump Air Regulator                                | <b>T</b> Ram Air Regulator  |
| <b>G</b> Air Manifold                                      | <b>U</b> Ram Director Valve   |
| <b>H</b> Electrically Conductive Air Supply Hose           | <b>V</b> Pump Runaway Valve (position only)                               |
| <b>J</b> Air Line Filter                                   | <b>W</b> Air Line Drain Valve   |
| <b>K</b> Air Shutoff Valve (for accessories)               | <b>Y</b> Ground Wire (required, see page 6 for installation instructions) |
| <b>L</b> Fluid Regulator                                   |   |

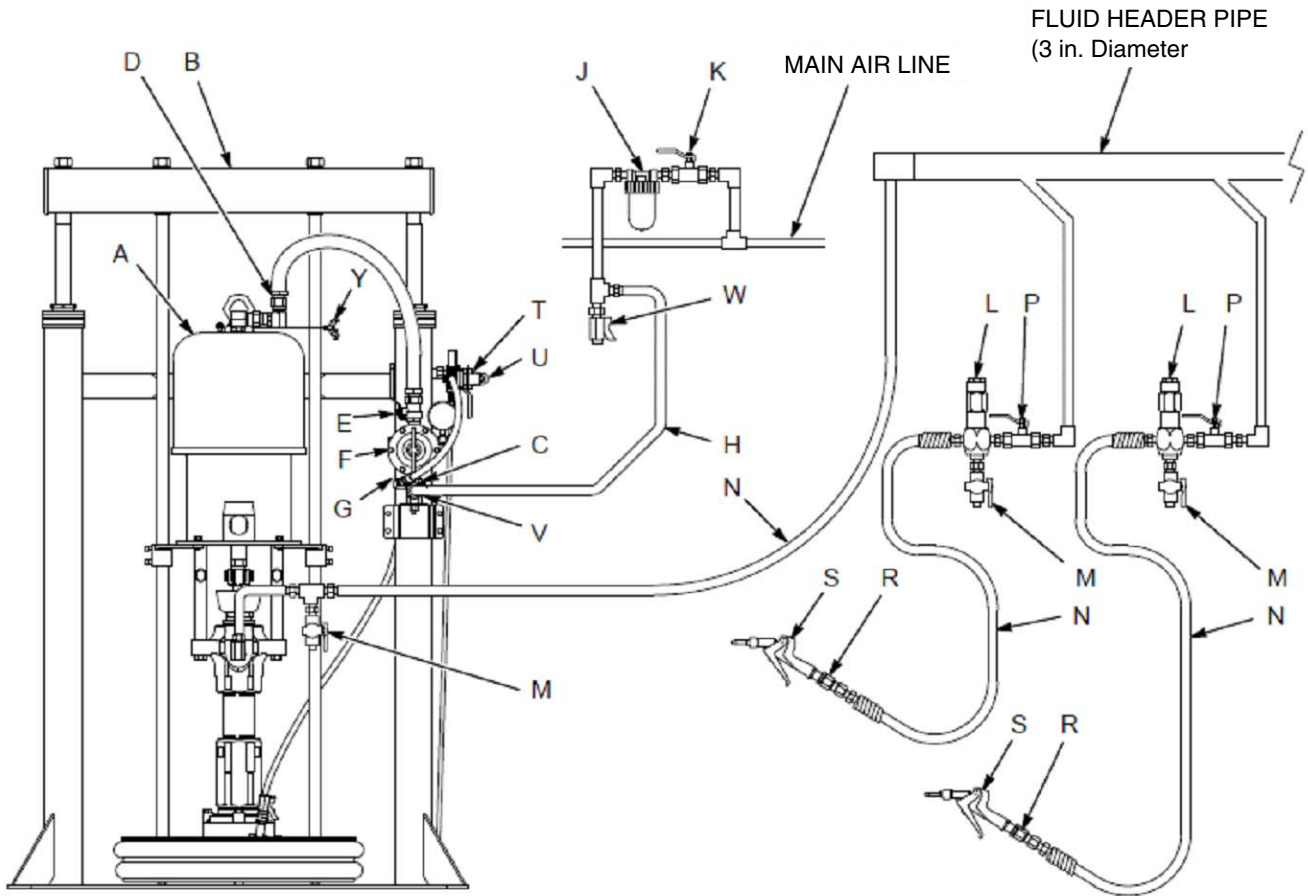

Fig.3

05097



# Installation (Air-Powered Pumps)

## **WARNING**

A main air bleed valve (C), pump air bleed valve (E), and fluid drain valve (M) are required. These accessories help reduce the risk of serious injury, including fluid injection and splashing of fluid in the eyes or on the skin, and injury from moving parts if you are adjusting or repairing the pump.

The main air bleed valve (C) shuts off the air to the pump and ram. The pump air bleed valve (E) relieves air trapped between this valve and the pump after the air is shut off. Trapped air can cause the pump to cycle unexpectedly. Locate the valve close to the pump. Order Part No. 107141.

The fluid drain valve assists in relieving fluid pressure in the displacement pump, hose, and gun. Triggering the gun to relieve pressure may not be sufficient. Order Part No. 210658.

### Air Line Accessories

Install the following accessories in the order shown in Fig. 3, using adapters as necessary:

- **An air line lubricator (D)** provides automatic air motor lubrication. Locate in the position shown.
- **A main air bleed valve (C)** is required in your system to shut off the air supply to the pump and ram (see the **WARNING** above). When closed, the valve will bleed off all air in the ram and pump, and the ram will slowly lower. Be sure the valve is easily accessible from the pump, and is located **upstream** from the air manifold (G).
- **A pump air bleed valve (E)** is required in your system to relieve air trapped between it and the air motor when the valve is closed (see the **WARNING** at left). Be sure the bleed valve is easily accessible from the pump, and is located **downstream** from the air regulator.
- **An air regulator (F)** controls pump speed and outlet pressure by adjusting the air pressure to the pump. Locate the regulator close to the pump, but **upstream** from the pump air bleed valve.
- **A pump runaway valve (V)** senses when the pump is running too fast and automatically shuts off the air to the motor. A pump which runs too fast can be seriously damaged. Locate in the position shown.
- **An air manifold (G)** has a swivel air inlet. It mounts to a ram, and has ports for connecting lines to air accessories, such as the **ram air regulator (T)** and **ram director valve (U)**.
- **An air line filter (J)** removes harmful dirt and moisture from the compressed air supply. Also, install a **drain valve (W)** at the bottom of each air line drop, to drain off moisture.
- **An air shutoff valve (K)** isolates the air line accessories for servicing. Locate upstream from all other air line accessories.

### Fluid Line Accessories

Install the following accessories in the positions shown in Figs. 3 and 4, using adapters as necessary:

- Install a **fluid shutoff valve (P)** at each gun/valve drop, to isolate the gun/valve and fluid accessories for servicing.
- Install a **fluid drain valve (M)** near the pump fluid outlet, and at each gun/valve station. The drain valves are required in your system to relieve fluid pressure in the displacement pump, hose and gun/valve (see the **WARNING** at left). Drain valves at the gun/valve stations may be mounted in the base of a **fluid regulator (L)**, using an adapter.
- **A fluid regulator (L)** controls fluid pressure to the gun/valve, and dampens pressure surges.
- **A gun or dispense valve (S)** dispenses the fluid. The gun shown in Fig. 3 is a high pressure dispensing gun for highly viscous fluids.
- **A gun/valve swivel (R)** allows freer gun/valve movement

# Installation (Hydraulic-Powered Pumps)

**KEY**

- |   |   |
|---|---|
| A Accessory Pump Stand<br>(P/N 218742)              | H Hydraulic Pressure Gauge                |
| B Surge Tank (P/N 218509 or<br>238983)              | J Flow Control Valve                      |
| C 50 mm (2 in.) Diameter Pipe                       | K Pressure Reducing Valve                 |
| D Full Flow, Non-Restrictive<br>Fluid Shutoff Valve | L Drain Line                              |
| E Fluid Supply Line                                 | M Hydraulic Return Line                   |
| F Mix Tank  | N Accumulator                             |
| G Hydraulic Supply Line<br>Shutoff Valve            | P Hydraulic Supply Line                   |
|   | Q Hydraulic Return Line                   |
|   | Y Ground Wire (required,<br>see page 6)L- |

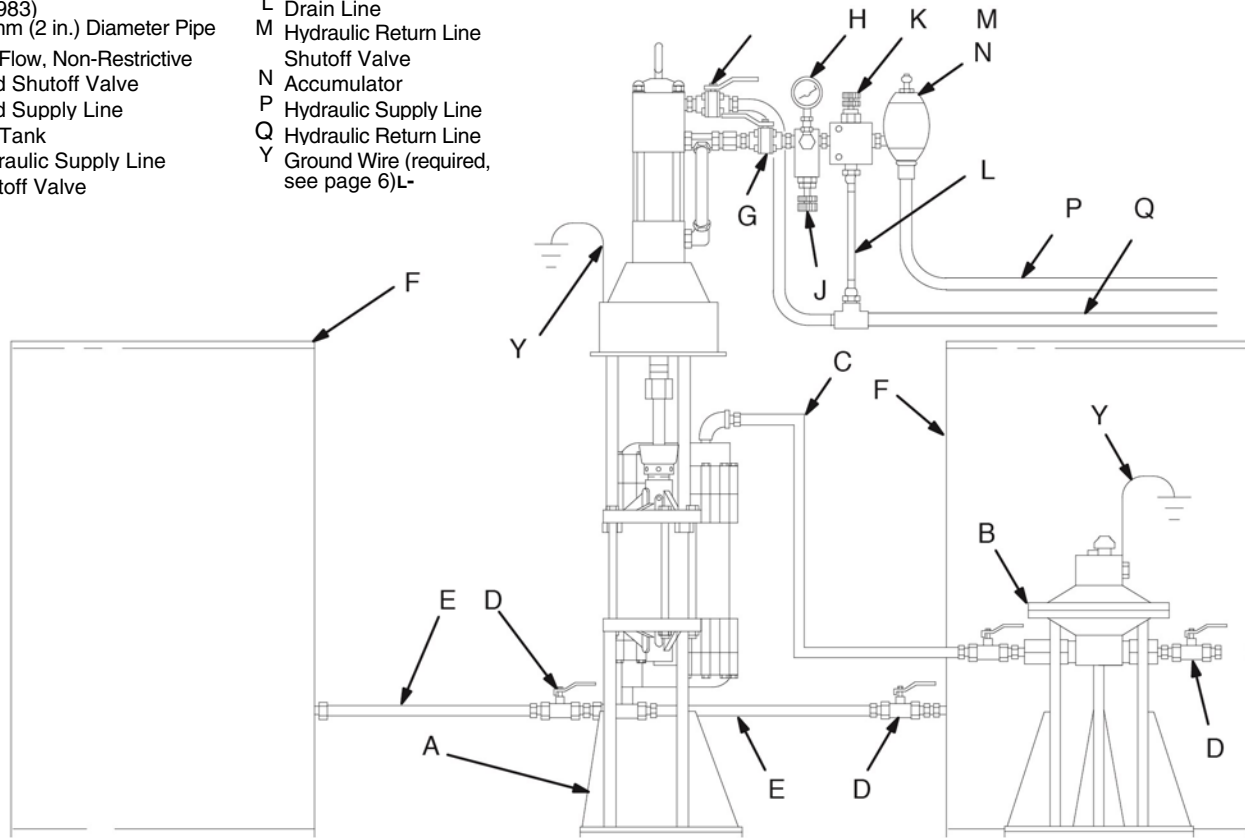

**Fig. 4**

01408

# Installation (Hydraulic–Powered Pumps)

## CAUTION

The Hydraulic Power Supply must be kept clean at all times to avoid damage to the motor and hydraulic power supply.

1. Blow out hydraulic lines with air and flush thoroughly before connection to the motor.
2. Plug hydraulic inlets, outlets, and line ends when disconnecting them for any reason.

Always plug the hydraulic inlets, outlets and lines when disconnecting them for any reason to avoid introducing dirt and other contaminants into the system.

Be sure that your hydraulic power supply is equipped with a suction filter to the hydraulic pump and a system return line filter of 10 micron size. Carefully follow the manufacturer's recommendations on reservoir and filter cleaning and periodic changes of hydraulic fluid.in

**NOTE:** Hydraulic fluid is exhausted from differential hydraulic motors only on the upstroke of the operating cycle. The oil return line must have at least twice the flow capacity as the oil supply line. Otherwise, back pressure on the hydraulic motor piston will slow down the motor and the fluid displacement pump, resulting in a loss of pump performance.

On the hydraulic oil supply line (P), install a shutoff valve (G) to isolate the system for servicing; a fluid pressure gauge (H) to monitor hydraulic oil pressure to the motor and avoid overpressurizing the motor or displacement pump; a pressure- and temperature-compensated flow control valve (J) to prevent the motor from running too fast; a pressure reducing valve (K) with a drain line (L) running directly into the hydraulic return line (Q); and an accumulator (N) to reduce the hammering effect caused by the motor reversing direction.

On the hydraulic return line (Q), install a shutoff valve (M) for isolating the motor for servicing.

# Operation

## Pressure Relief Procedure



### WARNING



#### SKIN INJECTION HAZARD

The system pressure must be manually relieved to prevent the system from starting or spraying accidentally.

Fluid under high pressure can be injected through the skin and cause serious injury. To reduce the risk of an injury from injection, splashing fluid, or moving parts, follow the **Pressure Relief Procedure** whenever you:

- are instructed to relieve the pressure,
- stop spraying/dispensing,
- check or service any of the system equipment,
- or install or clean the spray tip/nozzle.

1. Lock the gun/valve trigger safety.
2. Shut off the power to the pump.
3. **In an air-powered system**, close the air regulator and close the bleed-type master air valve.
4. **In a hydraulic-powered system**, close the hydraulic supply line shutoff valve first, then the return line shutoff valve.
5. Unlock the gun/valve trigger safety.
6. Hold a metal part of the gun/valve firmly to the side of a grounded metal pail, and trigger the gun/valve to relieve pressure.
7. Lock the gun/valve trigger safety.
8. **In an air-powered system**, open the drain valve (required in your system), having a container ready to catch the drainage. Leave the drain valve open until you are ready to spray/dispense again.

*If you suspect that the spray tip/nozzle or hose is completely clogged, or that pressure has not been fully relieved after following the steps above, very slowly loosen the tip guard retaining nut or hose end coupling and relieve pressure gradually, then loosen completely. Now clear the tip/nozzle or hose.*

### Packing Nut/Wet-Cup

Before starting, fill the packing nut (2) 1/3 full with Graco Throat Seal Liquid (TSL) or compatible solvent. See Fig. 5.



### WARNING

To reduce the risk of serious injury whenever you are instructed to relieve pressure, always follow the **Pressure Relief Procedure** at left.

The packing nut is torqued at the factory and is ready for operation. If it becomes loose and there is leaking from the throat packings, relieve pressure, then torque the nut to 128–156 N.m (95–115 ft-lb) using the supplied wrench (109). Do this whenever necessary. Do not overtighten the packing nut.

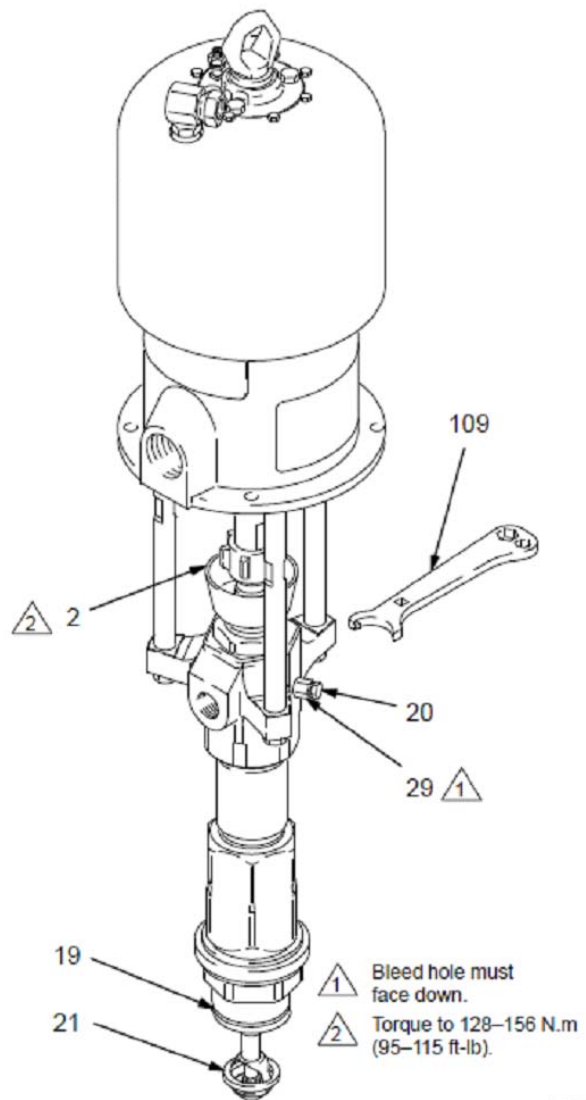

Fig.5

04095

# Operation

## Flush the Pump Before First Use

The pump is tested with lightweight oil, which is left in to protect the pump parts. If the fluid you are using may be contaminated by the oil, flush it out with a compatible solvent. See **Flushing** on page 16.

## Starting and Adjusting the Pump

### WARNING



#### MOVING PARTS HAZARD

Keep hands and fingers away from the priming piston (21) during operation and whenever the pump is charged with air.

The priming piston extends beyond the intake housing (19) to pull material into the pump and can amputate a hand or finger caught between it and the intake housing. Follow the **Pressure Relief Procedure** on page 12, before checking, clearing, or cleaning the priming piston.

### WARNING

**SKIN INJECTION HAZARD** To reduce the risk of fluid injection, **do not** use your hand or fingers to cover the bleed hole on the underside of the bleeder valve body (29) when priming the pump. Use a crescent wrench to open and close the bleeder plug (20). Keep your hands away from the bleed hole.

### CAUTION

Do not allow the pump to run dry. It will quickly accelerate to a high speed, causing damage. If your pump is running too fast, stop it immediately and check the fluid supply. If the container is empty and air has been pumped into the lines, refill the container and prime the pump and the lines, or flush and leave it filled with a compatible solvent. Eliminate all air from

### WARNING

#### COMPONENT RUPTURE HAZARD



To reduce the risk of overpressurizing your system, which could cause component rupture and serious injury, *never exceed the Maximum Input Pressure to the pump* (see the **Technical Data** on pages 38-46).

#### Air-Powered Systems

1. Supply fluid to the pump, per the requirements of your system.
  2. See Fig. 3. Close the air regulator (F).
  3. Open all air bleed valves (C, E).
  4. Hold a metal part of the gun/valve (S) firmly to the side of a grounded metal pail and hold the trigger open.
  5. Slowly open the air regulator until the pump starts.
  6. Cycle the pump slowly until all air is pushed out and the pump and hoses are fully primed.
  7. Release the gun/valve trigger and lock the trigger safety. The pump should stall against pressure.
  8. If the pump fails to prime properly, open the bleeder valve plug (20) slightly. Use the bleed hole, on the underside of the valve body (29), as a priming valve until the fluid appears at the hole. See Fig. 5. Close the plug.
- NOTE:** When changing fluid containers with the hose and gun/valve already primed, open the bleeder valve plug (20), to help prime the pump and vent air before it enters the hose. Close the plug when all air is eliminated.
9. With the pump and lines primed, and with adequate air pressure and volume supplied, the pump will start and stop as you open and close the gun/valve. In a circulating system, the pump will speed up or slow down on demand, until the air supply is shut off.
  10. Use the air regulator (F) to control the pump speed and the fluid pressure. Always use the lowest air pressure necessary to get the desired results. Higher pressures cause premature tip/nozzle and pump wear.

# Operation

## Hydraulic–Powered Systems

Refer to the warnings on page 13.

1. Supply fluid to the pump, per the requirements of your system.
2. Open the shutoff valves between the pump and supply tanks.
3. Open the dispensing valve(s) or spray gun(s).
4. To adjust the system, perform the following procedure:
  - a. Turn on the hydraulic power supply.
  - b. Open the flow control valve all the way.
  - c. Adjust the pressure–reducing valve until you get the desired fluid pressure. Run the pump until all air is purged from the fluid lines.
  - d. Count the cycle rate of the pump.
  - e. Close the flow control valve until the cycle rate and fluid pressure start to drop.
  - f. Open the flow control valve slightly until the cycle rate and fluid pressure return to the desired level. This method of setting the hydraulic controls ensures proper pump operation and will prevent pump runaway and damage if the fluid supply runs out.
  - g. Close the gun or valve.



# Maintenance

## Shutdown and Care of the Pump

### **WARNING**

To reduce the risk of serious injury whenever you are instructed to relieve pressure, always follow the **Pressure Relief Procedure** on page 12.

For overnight shutdown, stop the pump at the bottom of the stroke to prevent fluid from drying on the exposed displacement rod and damaging the throat packings.

**Relieve the pressure.**

Always flush the pump before the fluid dries on the displacement rod. Refer to **Flushing** below.

## Flushing

### **WARNING**

#### **FIRE AND EXPLOSION HAZARD**



Before flushing, read the section **FIRE AND EXPLOSION HAZARD** on page 5.



Be sure the entire system and flushing pails are properly grounded. Refer to **Grounding** on page 6.

Flush with a fluid that is compatible with the fluid you are pumping and with the wetted parts in your system. Check with your fluid manufacturer or supplier for recommended flushing fluids and flushing frequency. Always flush the pump before fluid dries on the displacement rod.

### **CAUTION**

Never leave water or water-base fluid in the pump overnight. If you are pumping water-base fluid, flush with water first, then with a rust inhibitor such as mineral spirits. Relieve the pressure, but leave the rust inhibitor in the pump to protect the parts from corrosion.

### **WARNING**

To reduce the risk of serious injury whenever you are instructed to relieve pressure, always follow the **Pressure Relief Procedure** on page 12.

1. **Relieve the pressure.**
2. Remove the spray tip/nozzle from the gun/valve.
3. Hold a metal part of the gun/valve firmly to the side of a grounded *metal* pail.
4. Start the pump. Always use the lowest possible fluid pressure when flushing.
5. Trigger the gun/valve.
6. Flush the system until clear solvent flows from the gun/valve.
7. **Relieve the pressure.**



# Troubleshooting

## **WARNING**

To reduce the risk of serious injury whenever you are instructed to relieve pressure, always follow the **Pressure Relief Procedure** on page 12.

1. **Relieve the pressure.**
2. Check all possible problems and causes before disassembling the pump.

PROBLEM	CAUSE	SOLUTION
Pump fails to operate.	Restricted air or hydraulic line or inadequate air supply; closed or clogged valves.	Clear any obstructions; check that all valves are open; increase pressure.
	Obstructed fluid hose or gun/valve; fluid hose ID is too small.	Open, clear*; use a hose with a larger ID.
	Fluid dried on the displacement rod.	Clean; always stop the pump at the bottom of its stroke; keep the wet-cup 1/3 filled with a compatible solvent.
	Dirty, worn, or damaged motor parts.	Clean or repair; see the separate motor manual.
Pump operates, but output low on both strokes.	Restricted air or hydraulic line or inadequate air supply; closed or clogged valves.	Clear any obstructions; check that all valves are open; increase pressure.
	Obstructed fluid hose or gun/valve; fluid hose ID is too small.	Open, clear*; use a hose with a larger ID.
	Bleeder valve is open.	Close the valve.
	Air is leaking into the supply container.	Check the ram plate seal.
	Fluid is too heavy for pump priming.	Use the bleeder valve (see page 13); use a ram.
	Held open or worn intake valve or seals.	Clear the valve; replace the seals.
	Worn packings in the displacement pump.	Replace the packings.
Pump operates, but output low on down- stroke.	Fluid too heavy for pump priming.	Use the bleeder valve (see page 13); use a ram.
	Held open or worn intake valve or seals.	Clear the valve; replace the seals.
Pump operates, but output low on upstroke.	Held open or worn piston valve or seals.	Clear the valve; replace the seals.
Erratic or accelerated pump speed.	Exhausted fluid supply.	Refill and prime.
	Fluid is too heavy for pump priming.	Use the bleeder valve (see page 13 or 14); use a ram.
	Held open or worn piston valve or seals.	Clear the valve; replace the seals.
	Held open or worn priming piston.	Clear; service.
	Worn packings in the displacement pump.	Replace the packings.

\* To determine if the fluid hose or gun is obstructed, follow the **Pressure Relief Procedure** on page 12. Disconnect the fluid hose and place a container at the pump fluid outlet to catch any fluid. Turn on the air or hydraulic power just enough to start the pump. If the pump starts, the obstruction is in the fluid hose or gun.

**NOTE:** If you experience air motor icing, call your Graco distributor.

# Service

## Required Tools

- Torque wrench
- Bench vise, with soft jaws
- Rubber mallet
- Hammer
- O-ring pick
- 13 mm (1/2 in.) dia. brass rod
- Set of socket wrenches
- Set of adjustable wrenches
- Pipe wrench
- Packing nut wrench (109, supplied)
- Thread lubricant
- Thread sealant

## Disconnecting the Displacement Pump

1. Flush the pump, if possible. Stop the pump at the bottom of its stroke.



## WARNING

To reduce the risk of serious injury whenever you are instructed to relieve pressure, always follow the **Pressure Relief Procedure** on page 12.

2. **Relieve the pressure.**
3. Disconnect all hoses from the pump and motor.

4. Disconnect the displacement pump (106) from the motor (101) as follows. See Fig. 6. Be sure to note the relative position of the pump's fluid outlet (X) to the motor inlet (Y). If the motor does not require servicing, leave it attached to its mounting.

## CAUTION

Be sure to use *at least* two people when lifting, moving, or disconnecting the pump. This pump is too heavy for one person. If you are disconnecting the displacement pump from a motor which is still mounted (for example, on a ram), *be sure* to support the displacement pump while it is being disconnected, to prevent it from falling and causing injury or property damage. Do this by securely bracing the pump, or by having at least two people hold it while another disconnects it.

5. Using an adjustable wrench (or a hammer and rod), unscrew the coupling nut (104) from the motor shaft (Z). Do not lose or drop the coupling collars (105). See Fig. 6.
6. Hold the tie rod flats with a wrench to keep the rods from turning. Unscrew the nuts (103) from the tie rods (102). Carefully remove the displacement pump (106) from the motor (101).
7. Refer to page 20 for displacement pump service. To service the motor, refer to the separate motor manual, supplied.

# Service

## Reconnecting the Displacement Pump

1. Make sure the coupling nut (104) and the coupling collars (105) are in place on the displacement rod (1). See Fig. 6.
2. Use at least two people to hold the displacement pump while another reconnects it to the motor (see the **CAUTION** on page 18). Orient the pump's fluid outlet (X) to the air or hydraulic inlet (Y) as was noted in step 4 under **Disconnecting the Displacement Pump**. Position the displacement pump (106) on the tie rods (102).
3. Screw the nuts (103) onto the tie rods (102) and torque to 68–81 N.m (50–60 ft-lb).
4. Screw the coupling nut onto the motor shaft loosely. Hold the motor shaft (Z) flats with a wrench to keep it from turning. Use an adjustable wrench to tighten the coupling nut. Torque to 196–210 N.m (145–155 ft-lb).
5. Torque the packing nut (2) to 128–156 N.m (95–115 ft-lb).
6. Reconnect all hoses. Reconnect the ground wire if it was disconnected. Fill the wet-cup (2) 1/3 full of Graco Throat Seal Liquid or compatible solvent.
7. Turn on the power supply. Run the pump slowly to ensure proper operation.

### **WARNING**

To reduce the risk of serious injury whenever you are instructed to relieve pressure, always follow the **Pressure Relief Procedure** on page 12.

8. Before returning the pump to production, relieve the pressure and retorque the packing nut (2) to 128–156 N.m (95–115 ft-lb).

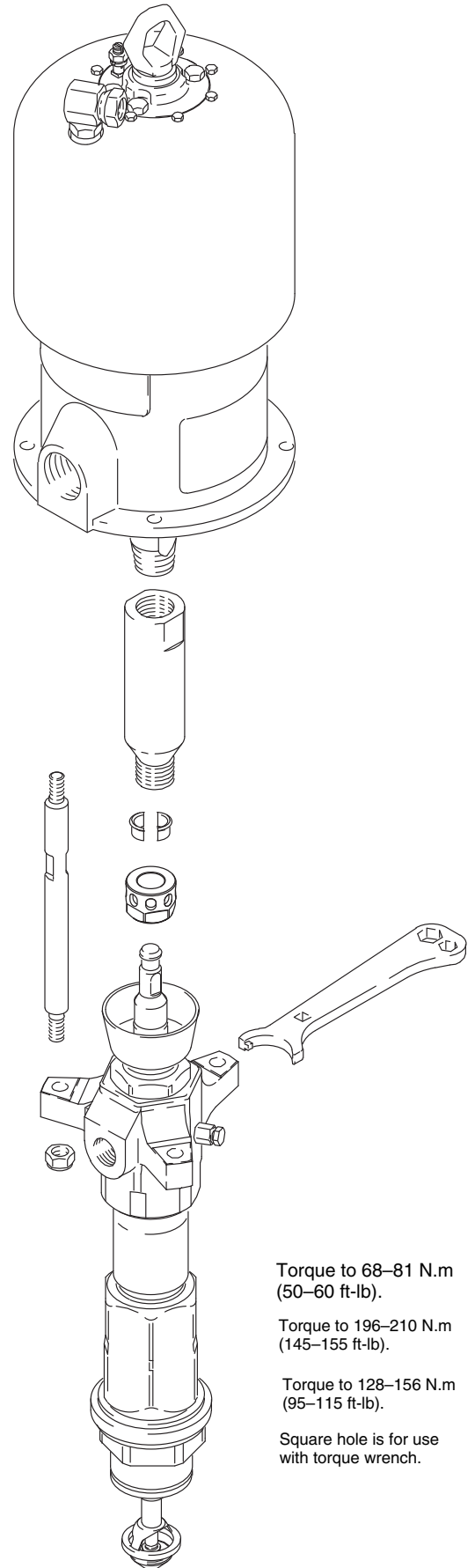

Fig. 6

# Displacement Pump Service

## Disassembly

When disassembling the pump, lay out all the removed parts in sequence, to ease reassembly. Clean all parts with a compatible solvent and inspect them for wear or damage. Refer to Fig. 9 for a cutaway view of the pump.

**NOTE:** Packing Repair Kits are available. See page 36. For the best results, use all the new parts in the kit. Kit parts are marked with an asterisk, for example (7\*).

1. Remove the displacement pump from the motor as explained on page 18. Place the pump in a vise, with the outlet housing (9) positioned as shown in Fig. 8.
2. Hold the flats of the priming piston rod (18) with an adjustable wrench, and use a second wrench to unscrew the priming piston seat (22) from the rod. Slide the priming piston (21) off the rod. Inspect the inner and outer surfaces of the piston (21) for scoring, wear, or other damage.
3. Loosen the packing nut (2) using the wrench (109) supplied.
4. Using a pipe wrench on the hex of the intake cylinder (19), unscrew it from the intake valve housing (17). The pump may separate at joints A, B, or C. See Fig. 8.

**NOTE:** These instructions are written with the pump separating at joint A. If it separates at joints B or C, disassemble it at that joint, place the intake housing (17) in a vise, and continue with step 5.

5. Unscrew the intake valve housing (17) from the cylinder (10). Pull the housing off the pump. The intake check valve assembly (V, see Fig. 7) should slide down the priming piston rod (18) as you remove the housing; if it does not slide easily, firmly tap on the top of the housing (17) with a rubber mallet to loosen.

## DETAIL OF INTAKE CHECK VALVE

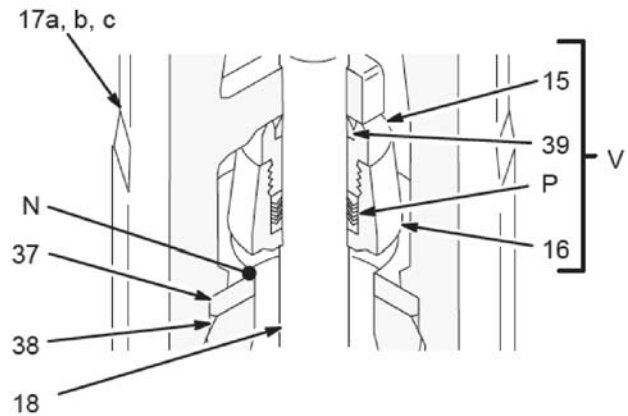

Fig. 7

05002

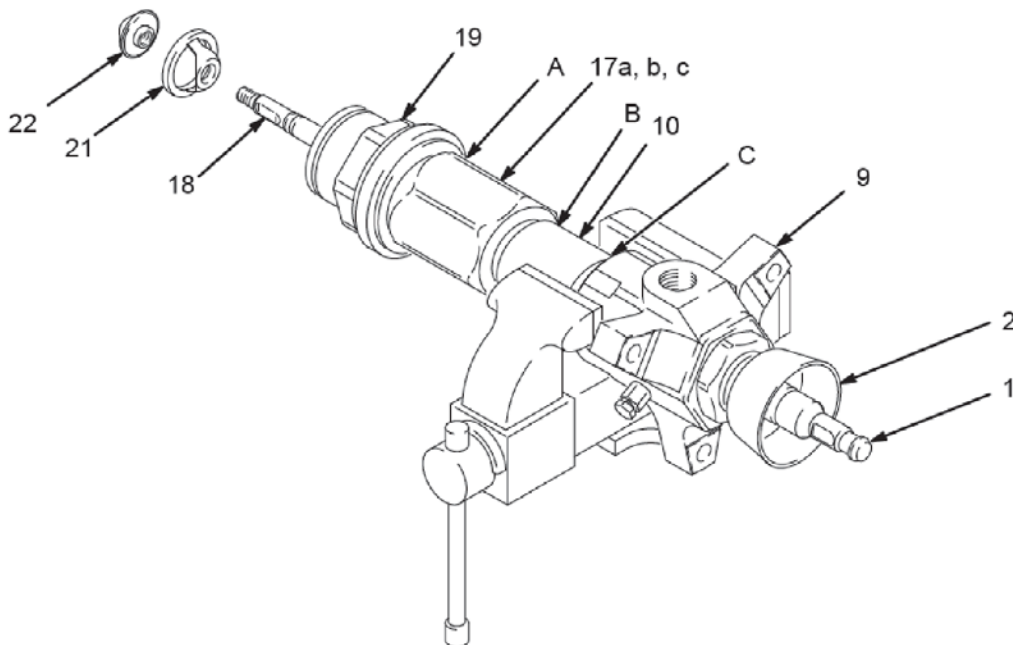

Fig. 8

04993

# Displacement Pump Service

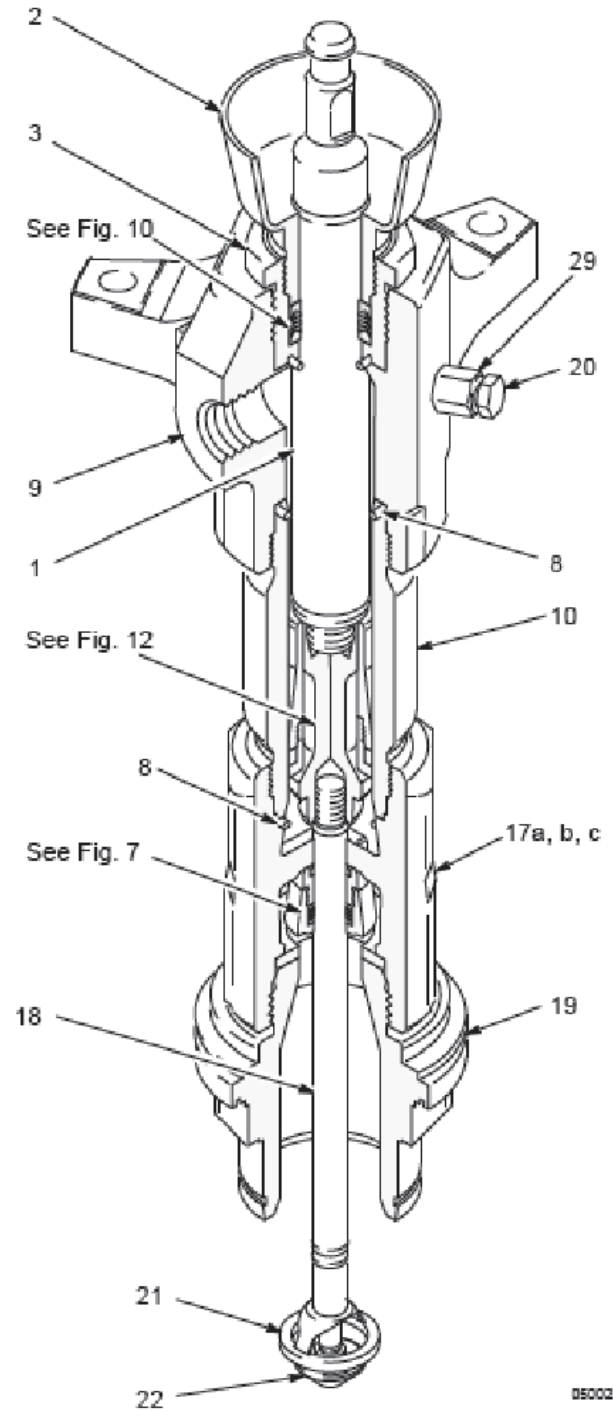

Fig. 9

6. Pull the intake seat (37) and seal (38) out the bottom of the intake valve housing (17). Take care not to drop the check valve assembly (V) as it comes free, and set it aside for later. See Fig. 7.

**NOTE:** If the seat (37) is difficult to remove, insert a hammer and brass rod through the top of the housing (17) and drive the seat out.

7. Using a rubber mallet, drive the displacement rod (1) and the priming piston rod (18) out of the outlet housing (9) and cylinder (10). Inspect the outer surfaces of the rods for damage by running a finger over the surface.
8. Unscrew the packing nut (2). Unscrew the packing housing (3) and remove the seal (42). Remove the throat glands and packings (T). See Fig. 10.

## THROAT PACKING DETAIL

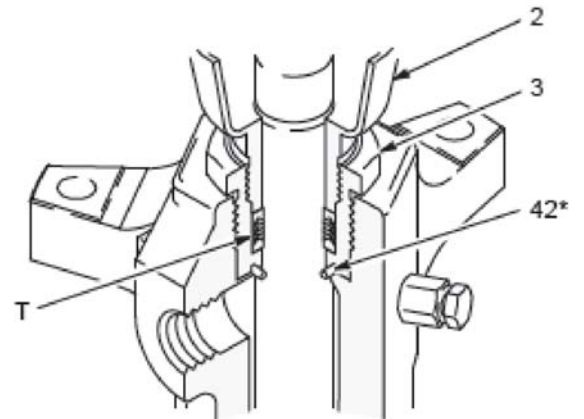

Fig. 10 Model 236611 Displacement Pump Shown

# Displacement Pump Service

9. Remove the seal (8) from the bottom of the cylinder (10). See Fig. 12. Shine a light into the cylinder to examine the inside surface for scoring or damage. **Only if the cylinder is damaged, or there is evidence of leaking around the top cylinder seal (8),** unscrew the cylinder from the outlet housing, using a pipe wrench. Remove the top cylinder seal.
10. Place the flats of the displacement rod (1) in a vise. Unscrew the piston (12) from the displacement rod; the priming piston rod (18) will come with it. Slide the piston guide (11) and seat (14) off the piston (12).
11. It is not necessary to remove the priming piston rod (18) from the piston (12) unless your inspection reveals damage to either part. To disassemble, place the piston flats in a vise and unscrew the rod.
12. Place the piston guide (11) in a vise, as shown in Fig. 11. Using an adjustable wrench, unscrew the piston seat (14) from the guide. Remove the seal (13); always replace it with a new one. Inspect the mating surfaces (M) of the piston (12) and piston seat (14) for damage or wear. See Fig. 12.
13. To disassemble the intake check valve assembly (V), place the intake valve body (16) in a vise and unscrew the packing nut (15). Remove the seal (39) from the nut, and the glands and packings (P) from the valve body. Inspect the mating surfaces (N) of the intake valve body (16) and seat (37) for damage or wear. See Figs. 7 and 13.

**NOTE:** The seal (39) is press-fit in the nut (15) and may require cutting to ease removal.

14. Unscrew the bleeder valve plug (20) completely from the valve body (29). Clean the valve threads and the bleed hole. It is not necessary to remove the valve body from the pump outlet housing (9).
15. Inspect all parts for damage. Clean all parts and threads with a compatible solvent. Reassemble as explained on page 23.

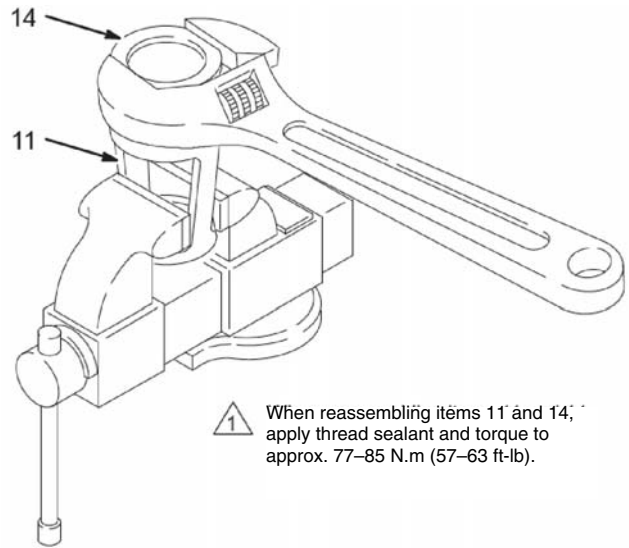

Fig. 11

03832

## DETAIL OF PISTON CHECK VALVE

- 1 Torque to 125–139 N.m (92–102 ft-lb).
- 2 Torque to 324–368 N.m (239–271 ft-lb).
- 3 Lubricate.

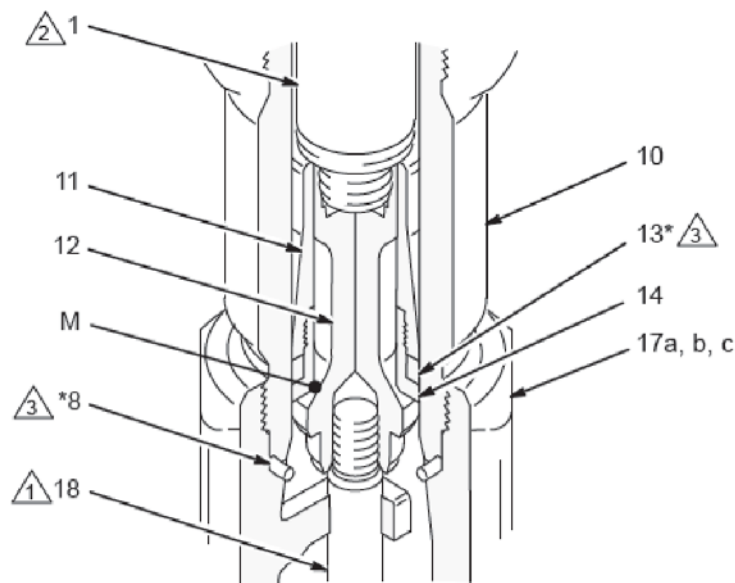

Fig. 12

05002



# Displacement Pump Service

- If the cylinder (10) was removed from the outlet housing (9), lubricate the seal (8\*) and place it on the top of the cylinder. (The cylinder is symmetrical, so either end can be the top.) Screw the cylinder into the outlet housing. See Fig. 16.
- Lubricate the seal (42\*) and install it in the groove on the bottom of the packing housing (3). Screw the packing housing into the outlet housing (9) and torque to 176–258 N.m (130–190 ft-lb). See the Detail in Fig. 16.
- Lubricate the throat packings and glands, and install them in the packing housing (3) one at a time, **with the lips of the v-packings facing down**. Install the v-packings in the order shown in the Detail in Fig. 16. Loosely install the packing nut (2).
- Lubricate the displacement rod (1). Slide the rod, piston assembly, and priming piston rod (18) into the cylinder (10) from the bottom, until the top of the rod (1) protrudes from the packing nut (2).
- Lubricate the seal (8\*) and install it on the bottom of the cylinder (10). Slide the intake valve housing (17) onto the priming piston rod (18), making certain that the smooth surface of the valve stop (VS) is facing down toward the pump intake. Screw the housing onto the cylinder. See Fig. 16.
- Lubricate the priming piston rod (18), then slide the assembled intake valve (V) onto the rod, making certain that the packing nut (15) goes on the rod first. Push the valve assembly up the rod, stopping before it reaches the intake valve housing (17). See Fig. 14.
- Hold the valve body (16) steady with a wrench while using an adjustable wrench to tighten the packing nut (15). See Fig. 14. Torque to 97–107 N.m (71–79 ft-lb). Use a rubber mallet on the priming piston rod (18), to drive the valve assembly up to the stop (VS).
- The intake seat (37) is reversible. Inspect both sides of the seat and install it with the best side facing into the housing (17). Push it into the housing until it seats securely. Lubricate the seal (38\*) and install in the bevel around the bottom of the seat. See Fig. 16.

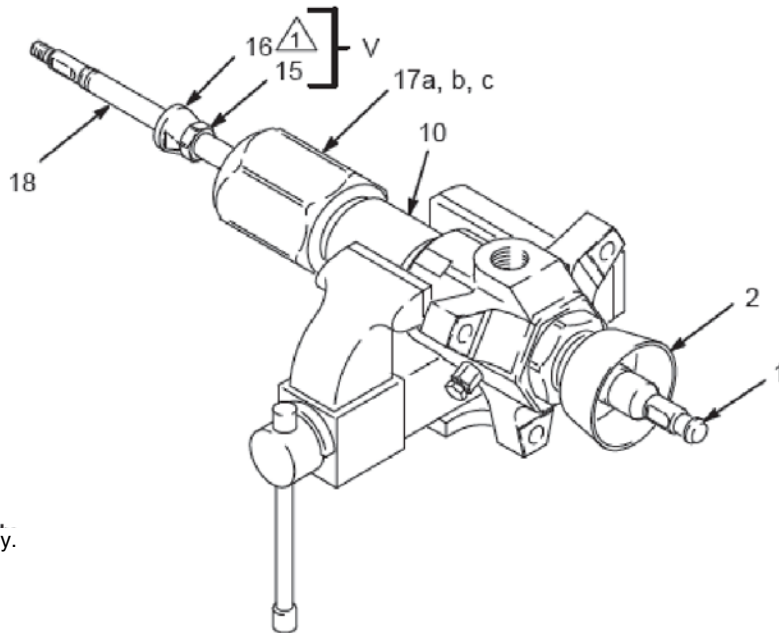

Fig. 14

04002



# Displacement Pump Service

15. Screw the intake cylinder (19) into the intake housing (17). Using a pipe wrench on the hex of the cylinder (19), torque the cylinder to 468–590 N.m (345–435 ft-lb). This will also torque the intake valve housing (17) and pump cylinder (10) into the outlet housing (9). See Fig. 15.
16. Screw the bleeder valve plug (20) into the valve body (29). The plug has two sets of threads. When reassembling, be sure to screw the plug completely into the valve body. See Fig. 16.
17. Check that the flats of the priming piston rod (18) are accessible below the intake cylinder (19). If not, tap on the top of the displacement rod (1) with a rubber mallet, until the flats are exposed.
18. Slide the priming piston (21) onto the rod (18) until it stops. Hold the rod (18) steady with an adjustable wrench on the flats, and screw the seat (22) onto the rod with another wrench. Torque to 77–85 N.m (57–63 ft-lb). See Fig.15.
19. Reconnect the displacement pump to the motor as explained on page 19.
20. Allow 2 hours for the thread sealant to cure before returning the pump to service.

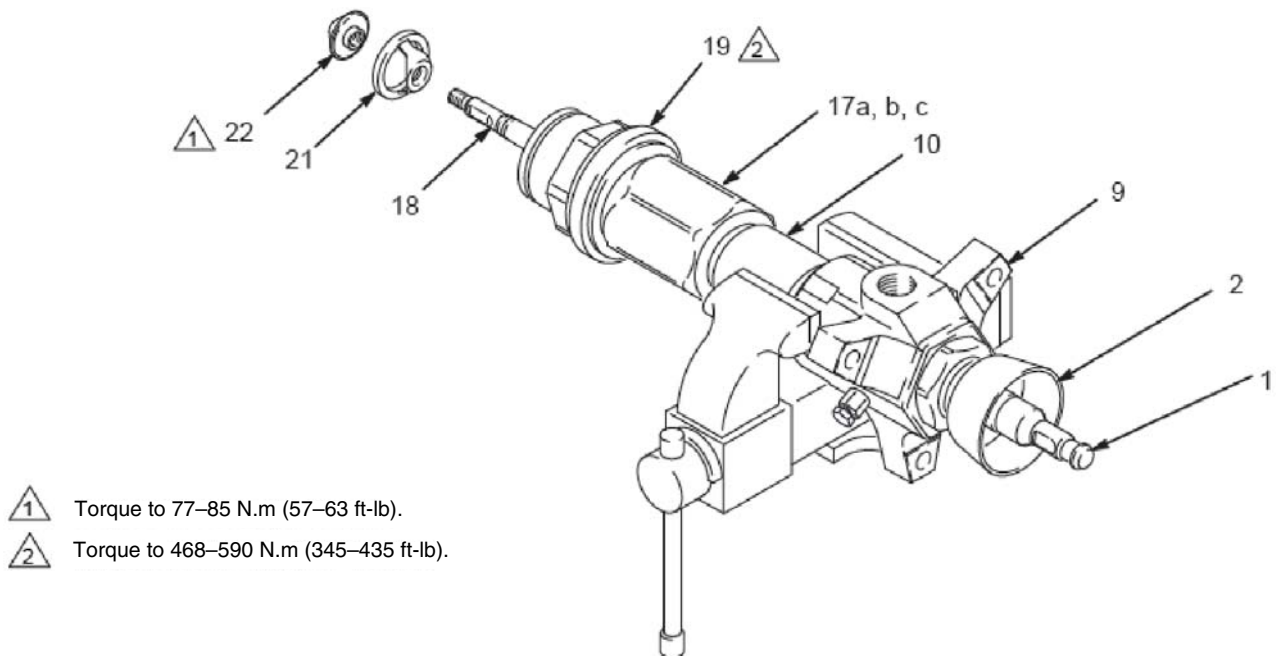
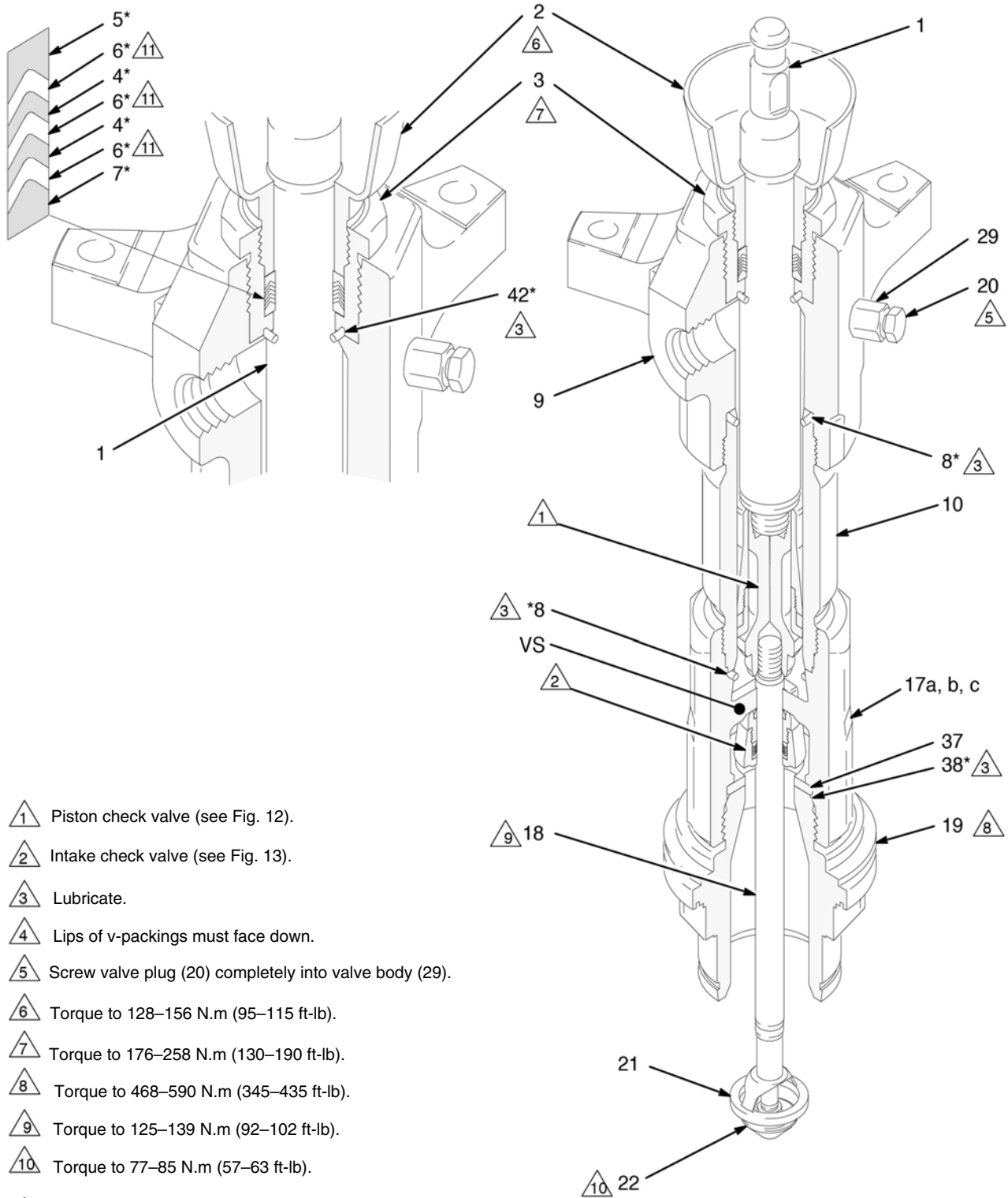

Fig. 15

# Displacement Pump Service

For Pumps 198466, 237265 and 236471 only

## THROAT PACKING DETAIL













-  1 Piston check valve (see Fig. 12).
-  2 Intake check valve (see Fig. 13).
-  3 Lubricate.
-  4 Lips of v-packings must face down.
-  5 Screw valve plug (20) completely into valve body (29).
-  6 Torque to 128–156 N.m (95–115 ft-lb).
-  7 Torque to 176–258 N.m (130–190 ft-lb).
-  8 Torque to 468–590 N.m (345–435 ft-lb).
-  9 Torque to 125–139 N.m (92–102 ft-lb).
-  10 Torque to 77–85 N.m (57–63 ft-lb).
-  11 Optional Displacement Pump 237945 uses all PTFE v-packings (item 4).

Fig. 16

05002

# Displacement Pump Service

For Pumps 246938, 246940, 246941 and 246942 only



## Servicing the Throat Packings

**NOTE:** The throat packings are available as a preassembled, pre-lubricated kit. For series B pumps, order Part No. 241782. For series A pumps order Part No. 237905. Parts included in these kits are marked with an asterisk, for example (3\*). Part No. 237905 includes items 3, 5 (qty: 1), 6, and 47.

### **WARNING**

To reduce the risk of serious injury whenever you are instructed to relieve pressure, always follow the **Pressure Relief Procedure** on page 12.

1. **Relieve the pressure.**
2. See Fig. 17. Unscrew the packing nut (2) using a pipe wrench. Remove the o-ring (6) and washer (47) from the bottom of the packing housing (3) or from the outlet housing (9).
3. Place the flats of the packing nut (2) in a vise. Unscrew the packing housing (3) and discard it and the packings. Remove the washer (46), seal (5), and backup washer (45) from the packing nut.
4. The throat repair kit is preassembled. Screw the kit into the packing nut (2), making sure that the backup washer (45\*), seal (5\*), and washer (46\*) are properly positioned on top of the packing housing (3\*), with the lips of the seal facing down. Torque the packing housing (3\*) to 97–106 N.m (71–78 ft-lb). See Fig. 17.
5. Check that the washer (47\*) and o-ring (6\*) are properly installed on the bottom of the packing housing (3\*).
6. Screw the packing nut (2) into the outlet housing (9). Torque to 190–217 N.m (140–160 ft-lb).

-  Torque to 97–106 N.m (71–78 ft-lb).
-  Torque to 190–217 N.m (140–160 ft-lb).
-  Lips of u-cup packing must face down.

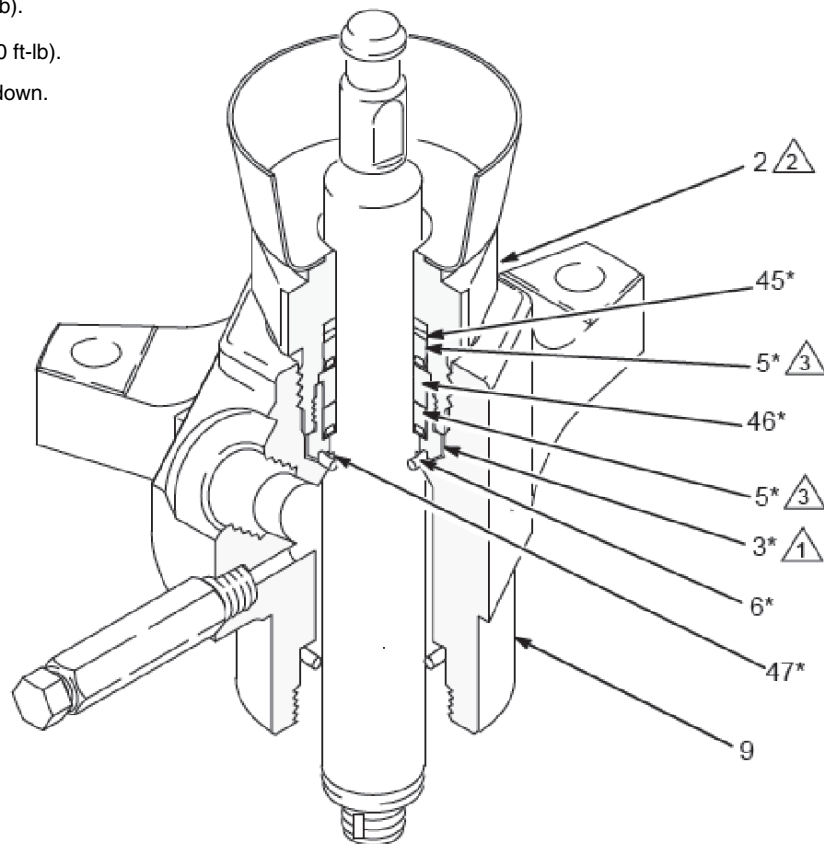

Fig. 17

5142C

# Parts

**Part No. 236471 Pump, Series B, 65:1 Ratio, with King Air Motor**

**Part No. 246942 Pump, Series B, 65:1 Ratio, with King Air Motor**

**Part No. 237261 Pump, Series A, 31:1 Ratio, with Bulldog Air Motor**

**Part No. 246940 Pump, Series B, 31:1 Ratio, with Bulldog Air Motor**

**Part No. 237264 Pump, Series A, 19:1 Ratio, with Senator Air Motor**

**Part No. 246941 Pump, Series B, 19:1 Ratio, with Senator Air Motor**

**Part No. 241901 Pump, Series A, 31:1 Ratio, with Bulldog Air Motor**

*Model 241901 Shown*

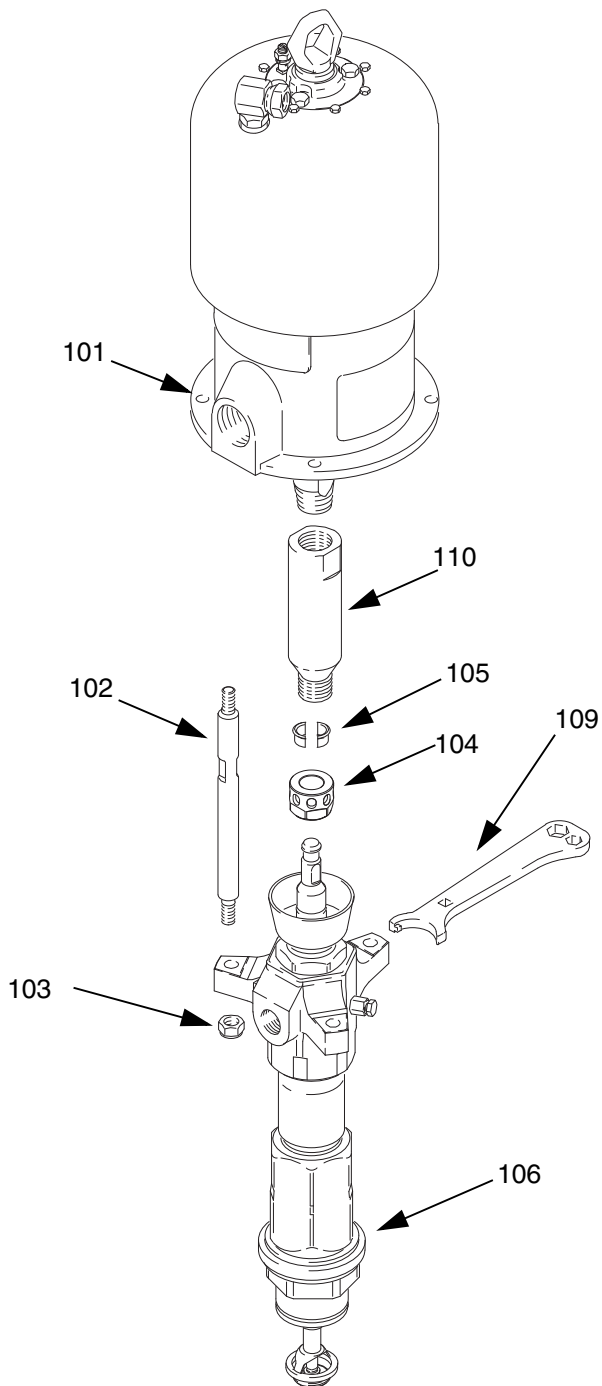

Ref. No.	Part No.	Description	Qty.
101	245111	AIR MOTOR, King <i>Used on Model 236471 and 246942 only. See 309347 for parts.</i>	1
	208356	AIR MOTOR, Bulldog <i>Used on Model 237261, 246940 and 241901. See 307049 for parts.</i>	1
	217540	AIR MOTOR, Senator <i>Used on Model 237264 and 246941 only. See 307592 for parts.</i>	1
102	190000	ROD, tie; 224 mm (8.82") shoulder to shoulder	3
	190437	ROD, tie; 380 mm (14.96") shoulder to shoulder <i>Used on Model 241901 only</i>	3
103	106166	NUT, hex; M16 x 2.0	3
104	186925	NUT, coupling	1
105	184129	COLLAR, coupling	2
106	236611	PUMP, displacement <i>See page 34 for parts</i>	1
	246939	PUMP, displacement <i>Used on Model 246942, 246940 and 246941 only. See page 32 for parts.</i>	1
109	112887	WRENCH, spanner	1
110	190436	ROD, connecting <i>Used on Model 241901 only</i>	1

# Parts

## Part No. 198475 Pump, Series A, 65:1 Ratio, with Quiet King Air Motor

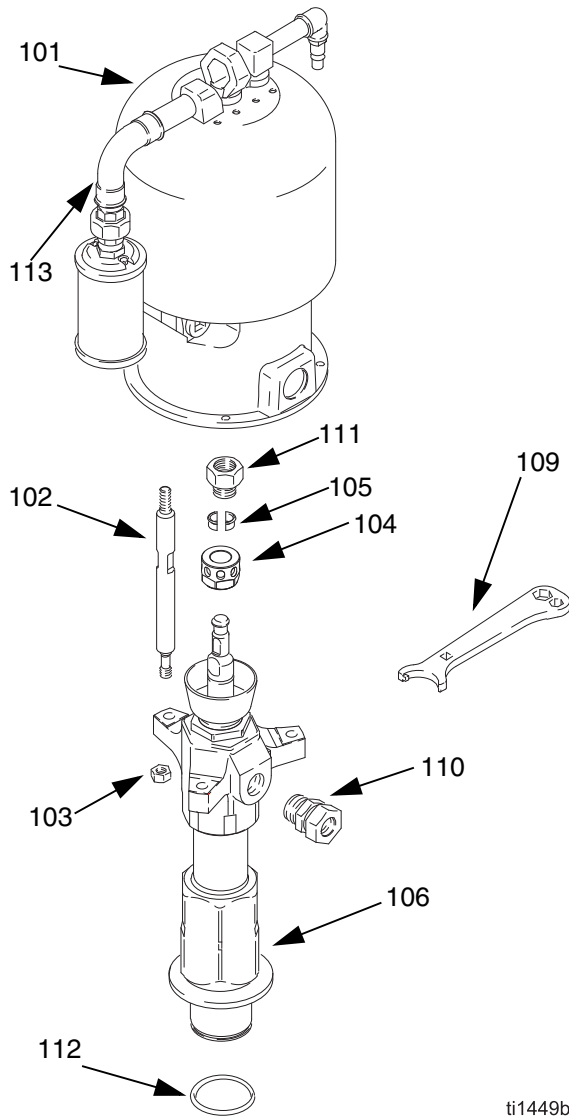

Ref. No.	Part No.	Description	Qty.
101	235525	AIR MOTOR, Quiet King See 309348 for parts	1
102	198476	ROD, tie; 271 mm (10.67") shoulder to shoulder	3
103	106166	NUT, hex; M16 x 2.0	3
104	186925	NUT, coupling	1
105	184129	COLLAR, coupling	2
106	198469	PUMP, displacement See page 34 for parts	1
109	112887	WRENCH, spanner	1
110	198465	FITTING, 1" npt	1
111	198477	ADAPTER	1
112	109482	PACKING, o-ring, fluoroelastomer	1
113	198478	KIT, accessory, intake and exhaust	1

ti1449b

# Parts

Part No. 198466 Pump, Series A, with Viscount II Hydraulic Motor

Part No. 246938 Pump, Series B, with Viscount II Hydraulic Motor

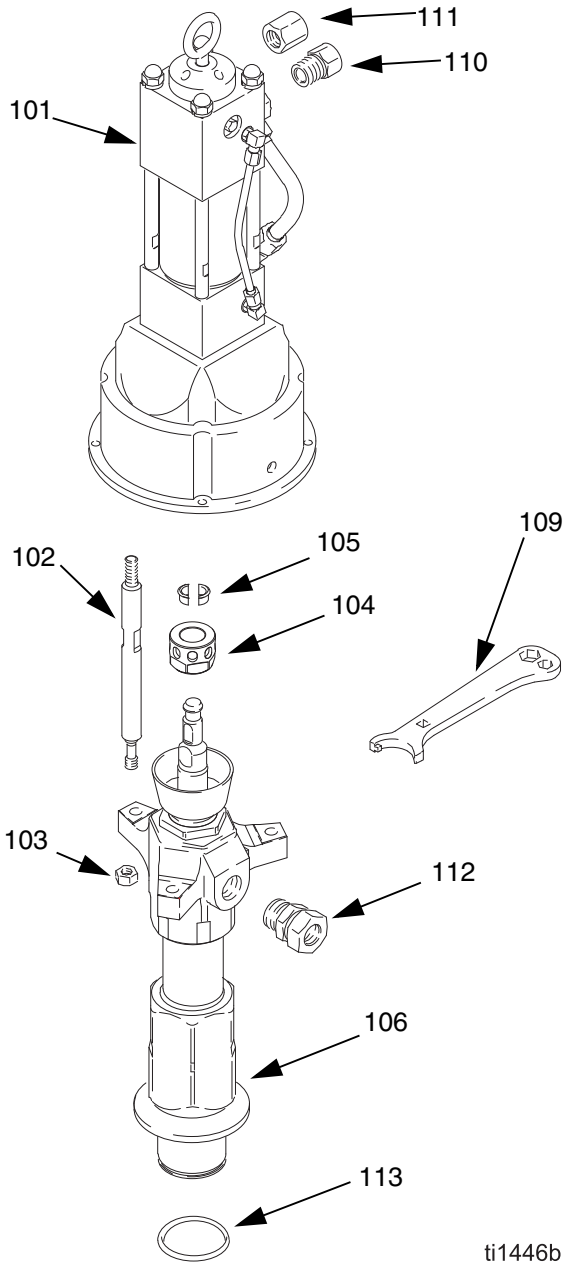

Ref. No.	Part No.	Description	Qty.
101	198468	MOTOR, Viscount II See 307158 for parts	1
102	198471	ROD, tie; 235 mm (9.25") shoulder to shoulder	3
103	106166	NUT, hex; M16 x 2.0	3
104	186925	NUT, coupling	1
105	184129	COLLAR, grounding	2
106	198469	PUMP, displacement <i>Used on Model 198466 only.</i> See page 34 for parts	1
	246939	PUMP, displacement <i>Used on Model 246938 only.</i> See page 32 for parts	1
109	112887	WRENCH, spanner	1
110	198473	FITTING, reducer	1
111	198472	FITTING, reducer	1
112	198465	FITTING, 1" npt	1
113	109482	PACKING, o-ring, fluoroeelastomer	1

ti1446b

# Parts

Part No. 237265 Pump, Series B, 65:1 Ratio, with Reduced Icing Quiet King Air Motor

Part No. 240945 Pump, Series B, 65:1 Ratio, with Quiet King Air Motor

Part No. 253376 Pump, Series C, 65:1 Ratio, with Quiet King Air Motor

Part No. 237274 Pump, Series A, 31:1 Ratio, with Reduced Icing Quiet Bulldog Air Motor

Model 237265 Shown

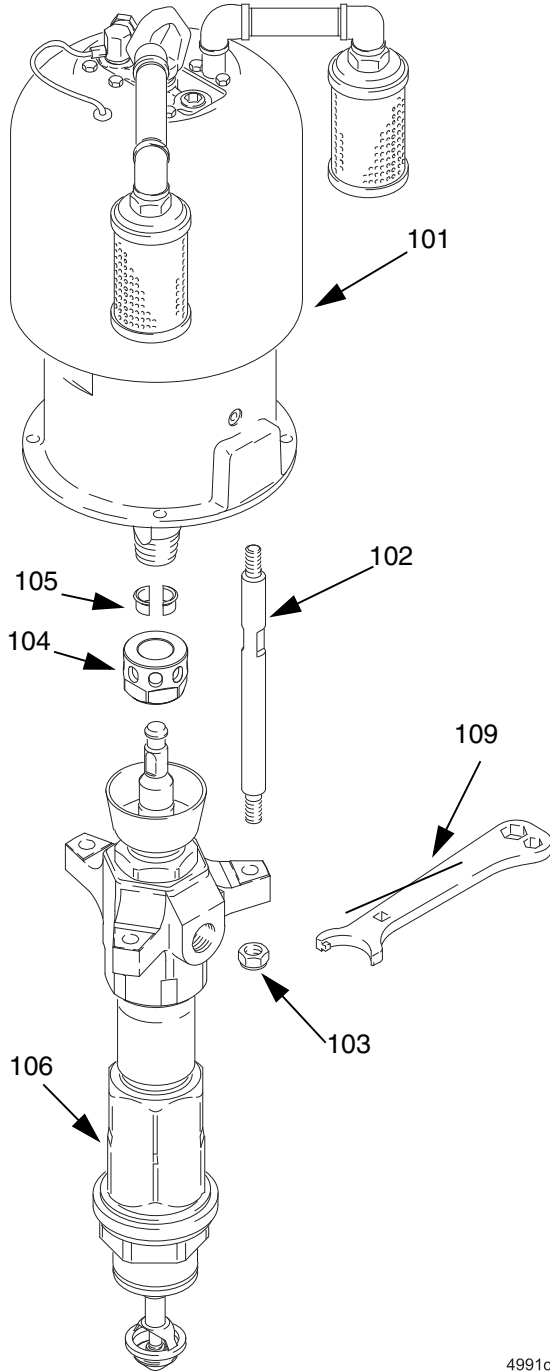

Ref. No.	Part No.	Description	Qty.
101	245112	AIR MOTOR, Reduced Icing Quiet King <i>Used on Model 237265 only</i> See 309348 for parts	1
	220106	AIR MOTOR, Quiet King <i>Used on Models 240945 and 253376 only; See 309348 for parts</i>	
	237001	AIR MOTOR, Reduced Icing Quiet Bulldog <i>Used on Model 237274 only</i> See 307304 for parts	1
102	190000	ROD, tie; 224 mm (8.82") shoulder to shoulder	3
103	106166	NUT, hex; M16 x 2.0	3
104	186925	NUT, coupling	1
105	184129	COLLAR, coupling	2
106	236611	PUMP, displacement See page 34 for parts	1
	237885	PUMP, displacement <i>Used on Model 253376 only</i> See manual 308570 for parts	1
109	112887	WRENCH, spanner	1

4991c

# Displacement Pump Parts

## Part No. 246939, Series B

Ref No.	Part No.	Description	Qty	Ref No.	Part No.	Description	Qty
1	189317	ROD, displacement; stainless steel	1	24★	109301	V-PACKING, intake valve; PTFE	1
2	237799	PACKING NUT/WET-CUP; carbon steel	1	25★	184196	GLAND, intake valve, female; carbon steel	1
3*	190585	HOUSING, throat seal; carbon steel	1	26★	109251	V-PACKING, intake valve; UHMWPE	1
5*†	113021	SEAL, u-cup, throat; PTFE with stainless steel spring	2	29	165702	BODY, bleeder valve; carbon steel	1
6*†	106258	O-RING; fluoroelastomer	1	30‡	172479	TAG, warning (not shown)	2
8*	109499	SEAL, cylinder; PTFE	2	37★	189446	SEAT, intake valve; chrome plated stainless steel	1
9	237567	HOUSING, outlet; ductile iron	1	38★	189492	SEAL, intake; PTFE	1
10	189437	CYLINDER, pump; stainless steel	1	39	189724	SEAL, intake valve; UHMWPE;	1
11	189438	GUIDE, piston; stainless steel	1	42	166073	SEAL; PTFE	1
12	189439	PISTON; stainless steel	1	43*†	19Y496	WASHER; seal backup	1
13★	189440	SEAL, piston; UHMWPE;	1	44*†	19Y497	WASHER; scraper	1
14	189441	SEAT, piston; stainless steel	1	45*†	19Y495	WASHER; rod scraper	1
15	189727	NUT, packing, intake valve; carbon steel	1	* <i>These parts are included in Throat Repair Kit 241782 (with housing), which may be purchased separately.</i>			
16A	189514	VALVE BODY, intake; chrome plated stainless steel	1	† <i>These parts are included in Throat Seal Kit 25A245 (without housing), which may be purchased separately.</i>			
17a	189442	HOUSING, intake; ductile iron	1	★ <i>These parts are included in Piston Seal Kit 25A246, which may be purchased separately.</i>			
17b‡	184090	LABEL, warning	1	‡ <i>Replacement Danger and Warning labels, tags and cards are available at no cost.</i>			
17c	100508	SCREW, drive	2				
18	184400	ROD, priming piston; stainless steel	1				
19	189447	CYLINDER, intake; ductile iron	1				
20	190128	PLUG, bleeder valve; carbon steel	1				
21	276378	PISTON, priming; stainless steel	1				
23★	184246	GLAND, intake valve, male;					



# Displacement Pump Parts

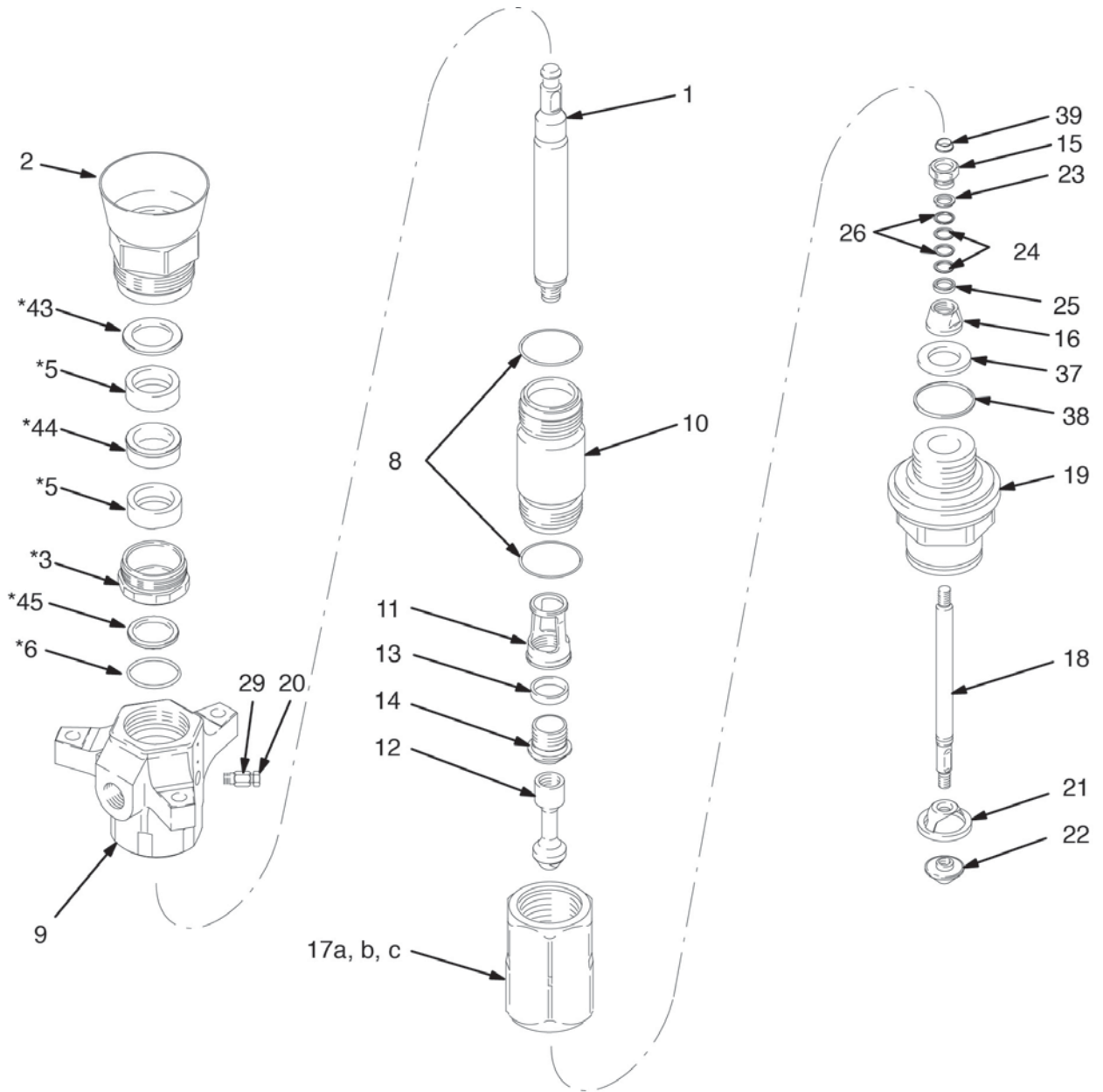

04989

# Displacement Pump Parts

## Part No. 236611, 198469 and 237945; Series A

**NOTE:** Refer to page 36 for the different packing configurations available.

Ref No.	Part No.	Description	Qty	Ref No.	Part No.	Description	Qty
1	189317	ROD, displacement; stainless	1	18	184400	ROD, priming piston; stainless steel	1
2	222995	PACKING NUT/WET-CUP; carbon steel	1	19	189447	CYLINDER, intake; ductile iron	1
3	189641	HOUSING, throat packing; carbon steel	1		198470	CYLINDER, intake; carbon steel	1
8*	109499	SEAL, cylinder; PTFE	2			<i>Used on Model 198469</i>	
9	237567	HOUSING, outlet; ductile iron	1	20	190128	PLUG, bleeder valve; carbon steel	1
10	189437	CYLINDER, pump; stainless steel	1	21	276378	PISTON, priming; stainless steel	1
11	189438	GUIDE, piston; stainless steel	1	22	190241	SEAT, priming piston; stainless steel	1
12	189439	PISTON; stainless steel	1	29	165702	BODY, bleeder valve; carbon steel	1
13*	189440	SEAL, piston; UHMWPE;	1	30‡	172479	TAG, warning (not shown)	1
		Used on Models 236611 and		37	189446	SEAT, intake valve; chrome plated stainless steel	1
	190015	SEAL, piston; PTFE;		38*	189492	SEAL, intake; PTFE	1
		Used on Model 237945 only	1	39*	189724	SEAL, intake valve; UHMWPE;	1
14	189441	SEAT, piston; stainless steel	1			<i>Used on Models 236611 and 198469</i>	
15	189727	NUT, packing, intake valve; carbon steel	1		189725	SEAL, intake valve; PTFE;	1
16	189514	VALVE BODY, intake; chrome plated stainless steel	1			<i>Used on Model 237945 only</i>	
17a	189442	HOUSING, intake; ductile iron	1	42*	166073	SEAL; PTFE	1
17b‡	184090	LABEL, warning	1				
17c	100508	SCREW, drive	2				

\* These parts are included in the pump repair kit. See page 36 for the applicable kit for your pump.

‡ Replacement Danger and Warning labels, tags and cards are available at no cost.

# Displacement Pump Parts

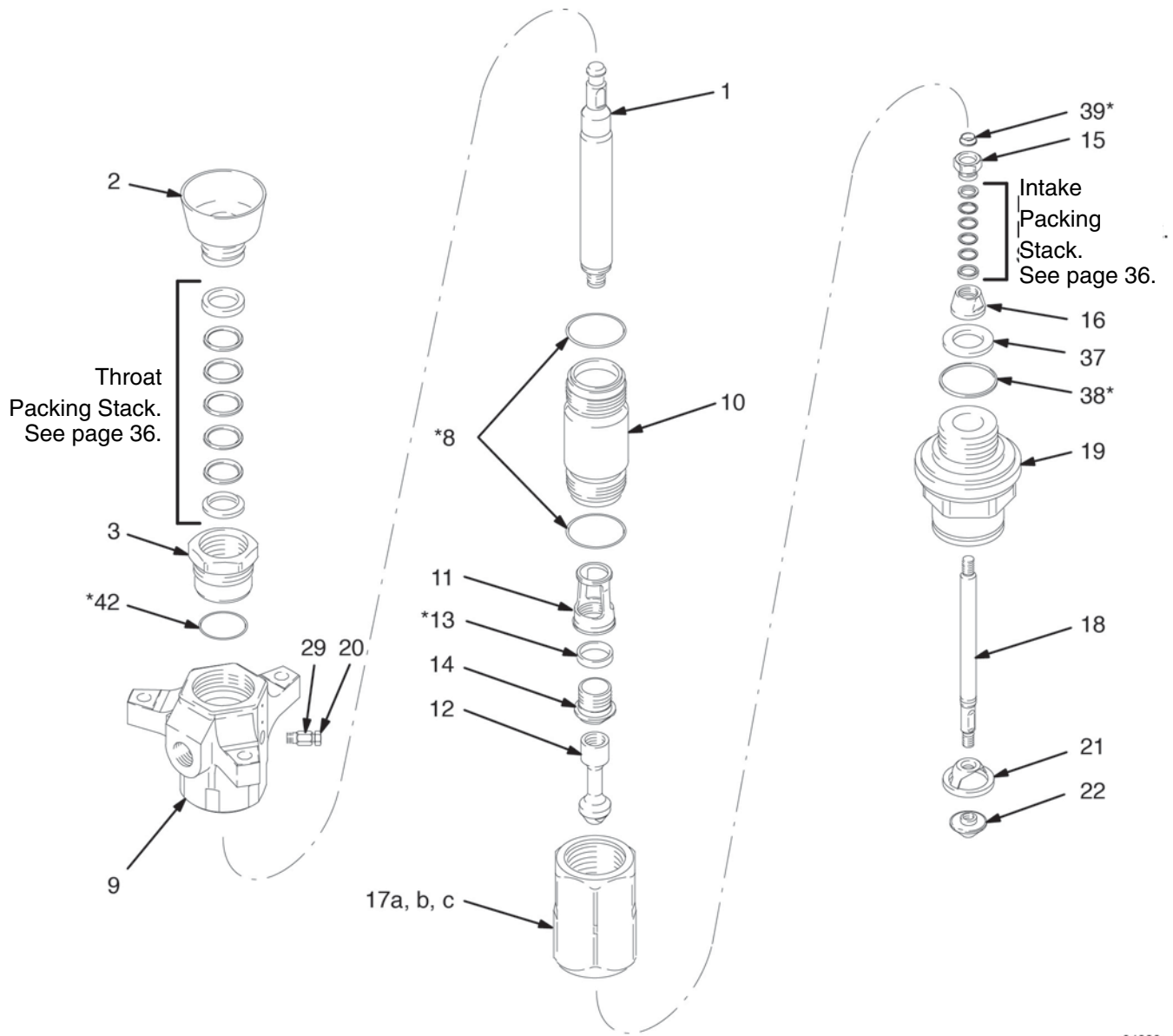

04989

# Displacement Pump Parts

## Part No. 236611 and 198469, Series A,

### Standard UHMWPE/PTFE Packed Displacement Pump

Ref No.	Part No.	Description	Qty
4*	109306	V-PACKING, throat; PTFE	2
5*	184201	GLAND, throat, female; carbon steel	1
6*	109256	V-PACKING, throat; UHMWPE	3
7*	184251	GLAND, throat, male; carbon steel	1
23*	184246	GLAND, intake valve, male; carbon steel	1
24*	109301	V-PACKING, intake valve; PTFE	2
25*	184196	GLAND, intake valve, female; carbon steel	1
26*	109251	V-PACKING, intake valve; UHMWPE	2

\* These parts are included in Repair Kit 222864, which may be purchased separately. See page 34 for additional parts included in the kit.

**THROAT PACKINGS:  
LIPS FACE DOWN**

**INTAKE PACKINGS:  
LIPS FACE UP**

**LUBRICATE PACKINGS**

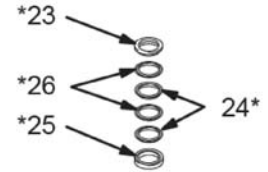
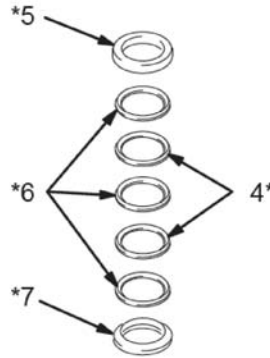

04989

## Part No. 237945, Series A, Optional PTFE Packed Displacement Pump

Ref No.	Part No.	Description	Qty
4*	109306	V-PACKING, throat; PTFE	5
5*	184201	GLAND, throat, female; carbon steel	1
7*	184251	GLAND, throat, male; carbon steel	1
23*	184246	GLAND, intake valve, male; carbon steel	1
24*	109301	V-PACKING, intake valve; PTFE	4
25*	184196	GLAND, intake valve, female; carbon steel	1

**THROAT PACKINGS:  
LIPS FACE DOWN**

**INTAKE PACKINGS:  
LIPS FACE UP**

**LUBRICATE PACKINGS**

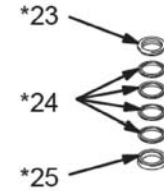
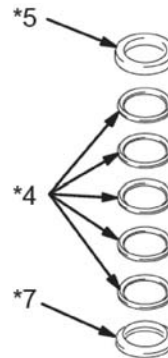

04989

\* These parts are included in Repair Kit 222865, which may be purchased separately. See page 34 for additional parts included in the kit.



# Technical Data

(Model 236471 and 246942 King Pumps)

## WARNING

Be sure that all fluids and solvents used are chemically compatible with the Wetted Parts listed below. Always read the manufacturer's literature before using fluid or solvent in this pump.

Category	Data
Ratio	65:1
Maximum fluid working pressure	236471: 40 MPa, 403 bar (5850 psi) 246942: 48 MPa, 483 bar (7000 psi)
Maximum air input pressure	236471: 0.6 MPa, 6 bar (90 psi) 246942: 0.7 MPa, 7 bar (100 psi)
Pump cycles per 3.8 liters (1 gal.)	21
Fluid flow at 60 cycles/min	10.6 liters/min (2.8 gpm)
Air motor piston effective area	506 cm <sup>2</sup> (78.5 in. <sup>2</sup> )
Stroke length	120 mm (4.75 in.)
Displacement pump effective area	8 cm <sup>2</sup> (1.24 in. <sup>2</sup> )
Maximum pump operating temperature	82 C (180° F)
Air inlet size	3/4 npsm(f)
Fluid outlet size	1" npt(f)
Weight	approx. 73 kg (160 lb)
Displacement pump weight	approx. 37 kg (81 lb)
Wetted parts	Carbon Steel; Chrome, Zinc, and Nickel Plating; 304, 316, 440, and 17-4 PH Grades of Stainless Steel; Alloy Steel; Ductile Iron; PTFE; Glass-Filled PTFE; Ultra-High Molecular Weight Polyethylene

### Sound Pressure Levels dB(A) (measured at 1 meter from unit)

Air Motor	Input Air Pressures at 15 cycles per minute		
	0.3 MPa, 2.8 bar (40 psi)	0.5 MPa, 4.8 bar (70 psi)	0.6 MPa, 6.2 bar (90 psi)
King	78.8 dB(A)	82.7 dB(A)	90.5 dB(A)

### Sound Power Levels dB(A) (tested in accordance with ISO 9614-2)

Air Motor	Input Air Pressures at 15 cycles per minute		
	0.3 MPa, 2.8 bar (40 psi)	0.5 MPa, 4.8 bar (70 psi)	0.6 MPa, 6.2 bar (90 psi)
King	86.5 dB(A)	88.8 dB(A)	97.7 dB(A)

# Technical Data

(Model 236471 and 246942 King Pumps)

## Performance Charts

**To find Fluid Outlet Pressure** (psi/MPa/bar) at a specific fluid flow (lpm/gpm) and operating air pressure (psi/MPa/bar):

1. Locate desired flow along bottom of chart.
2. Follow vertical line up to intersection with selected fluid outlet pressure curve (black). Follow left to scale to read fluid outlet

**To find Pump Air Consumption** (m<sup>3</sup>/min or scfm) at a specific fluid flow (lpm/gpm) and air pressure (psi/MPa/bar):

1. Locate desired flow along bottom of chart.
2. Read vertical line up to intersection with selected air consumption curve (dashes). Follow left to scale to read air consumption.

- A 0.6 MPa, 6.2 bar (90 psi) air pressure
- B 0.5 MPa, 4.9 bar (70 psi) air pressure
- C 0.3 MPa, 2.8 bar (40 psi) air pressure

### Test Fluid: No. 10 Weight Oil

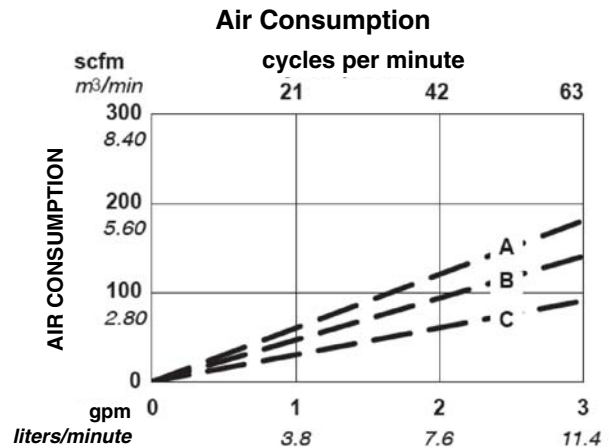
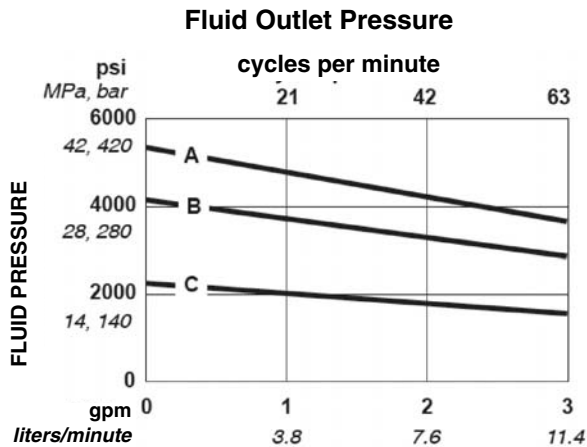

### Test Fluid: 4 Million CPS Weldable Rubber Base Sealer

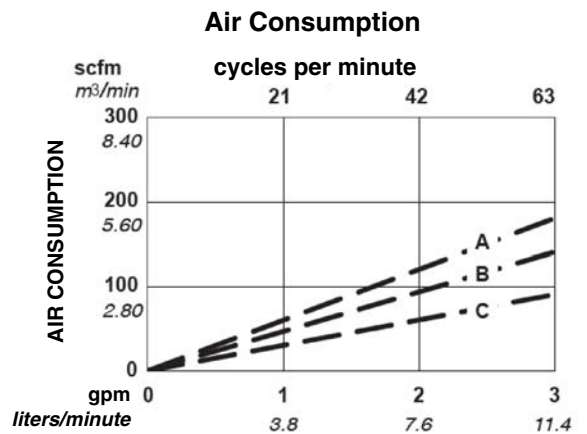
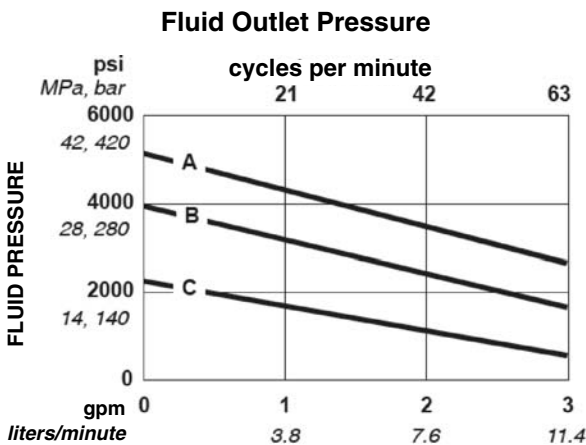

# Technical Data

(Models 240945, 253376, and 198475 Quiet King Pump and Model 237265 Reduced Icing Quiet King Pump)

## WARNING

Be sure that all fluids and solvents used are chemically compatible with the Wetted Parts listed below. Always read the manufacturer's literature before using fluid or solvent in this pump.

Category	Data
Ratio	65:1
Maximum fluid working pressure	40 MPa, 403 bar (5850 psi)
Maximum air input pressure	0.6 MPa, 6 bar (90 psi)
Pump cycles per 3.8 liters (1 gal.)	21
Fluid flow at 60 cycles/min	10.6 liters/min (2.8 gpm)
Air motor piston effective area	506 cm <sup>2</sup> (78.5 in. <sup>2</sup> )
Stroke length	120 mm (4.75 in.)
Displacement pump effective area	8 cm (1.24 in. <sup>2</sup> )
Maximum pump operating temperature	82° C (180° F)
Air inlet size	<i>Models 240945, 253376, and 237265: 3/4 npsm(f)</i> <i>Model 198475: G1/2</i>
Fluid outlet size	1" npt(f)
Weight	approx. 73 kg (160 lb)
Displacement pump weight	approx. 37 kg (81 lb)
Wetted parts	Carbon Steel; Chrome, Zinc, and Nickel Plating; 304, 316, 440, and 17-4 PH Grades of Stainless Steel; Alloy Steel; Ductile Iron; PTFE; Glass-Filled PTFE; Ultra-High Molecular Weight Polyethylene <i>Model 253376: See manual 308570</i>

### Sound Pressure Levels dB(A) (measured at 1 meter from unit)

Air Motor	Input Air Pressures at 15 cycles per minute		
	0.3 MPa, 2.8 bar (40 psi)	0.5 MPa, 4.8 bar (70 psi)	0.6 MPa, 6.2 bar (90 psi)
Quiet King	77.9 dB(A)	79.2 dB(A)	87.5 dB(A)

### Sound Power Levels dB(A) (tested in accordance with ISO 9614-2)

Air Motor	Input Air Pressures at 15 cycles per minute		
	0.3 MPa, 2.8 bar (40 psi)	0.5 MPa, 4.8 bar (70 psi)	0.6 MPa, 6.2 bar (90 psi)
Quiet King	85.2 dB(A)	86.6 dB(A)	95.2 dB(A)



# Technical Data

(Models 240945, 253376, and 198475 Quiet King Pump and Model 237265 Reduced Icing Quiet King Pump)

## Performance Charts

**To find Fluid Outlet Pressure** (psi/MPa/bar) at a specific fluid flow (lpm/gpm) and operating air pressure (psi/MPa/bar):

1. Locate desired flow along bottom of chart.
2. Follow vertical line up to intersection with selected fluid outlet pressure curve (black). Follow left to scale to read fluid outlet pressure.

**To find Pump Air Consumption** (m<sup>3</sup>/min or scfm) at a specific fluid flow (lpm/gpm) and air pressure (psi/MPa/bar):

1. Locate desired flow along bottom of chart.
2. Read vertical line up to intersection with selected air consumption curve (dashes). Follow left to scale to read air consumption.

- A 0.6 MPa, 6.2 bar (90 psi) air pressure
- B 0.5 MPa, 4.9 bar (70 psi) air pressure
- C 0.3 MPa, 2.8 bar (40 psi) air pressure

### Test Fluid: No. 10 Weight Oil

**Fluid Outlet Pressure**

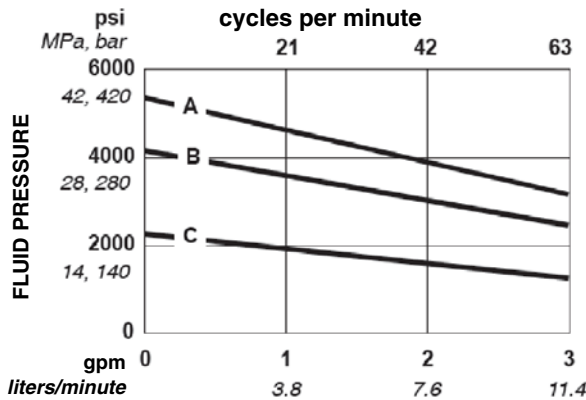

**Air Consumption**

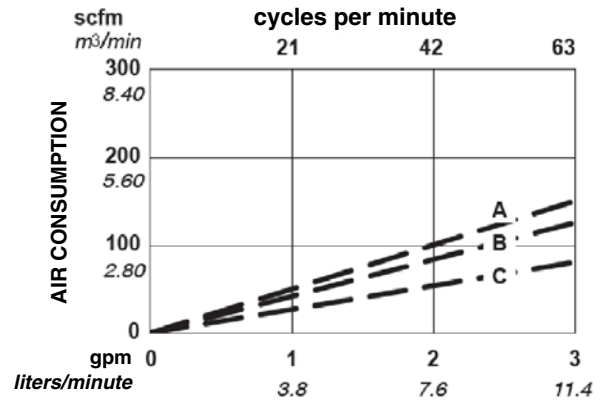

### Test Fluid: 4 Million CPS Weldable Rubber Base Sealer

**Fluid Outlet Pressure**

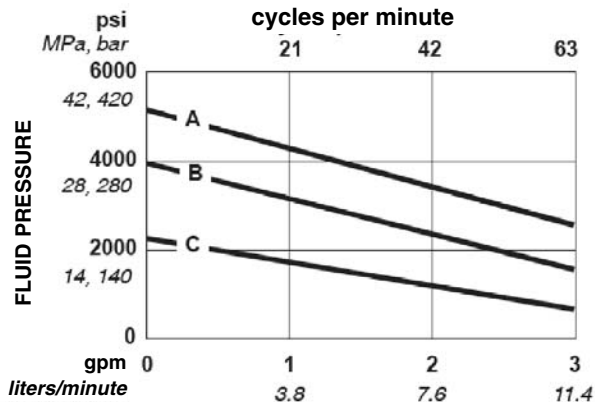

**Air Consumption**

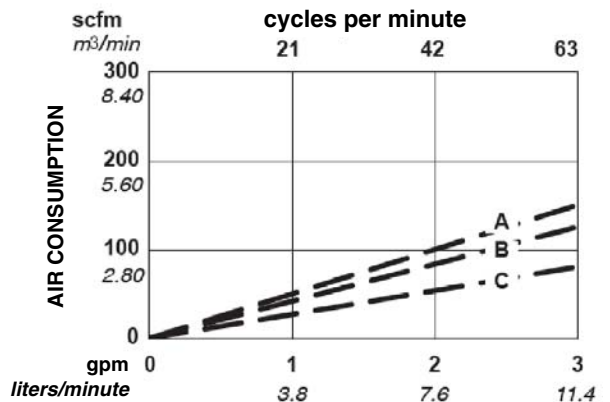

# Technical Data

(Model 237261, 246940 and 241901 Bulldog Pumps)

## WARNING

Be sure that all fluids and solvents used are chemically compatible with the Wetted Parts listed below. Always read the manufacturer's literature before using fluid or solvent in this pump.

Category	Data
Ratio	31:1
Maximum fluid working pressure	21 MPa, 214 bar (3100 psi)
Maximum air input pressure	0.7 MPa, 7 bar (100 psi)
Pump cycles per 3.8 liters (1 gal.)	21
Fluid flow at 60 cycles/min	10.6 liters/min (2.8 gpm)
Air motor piston effective area	248 cm <sup>2</sup> (38 in. <sup>2</sup> )
Stroke length	120 mm (4.75 in.)
Displacement pump effective area	8 cm <sup>2</sup> (1.24 in. <sup>2</sup> )
Maximum pump operating temperature	82°C (180°F)
Air inlet size	3/4 npsm(f)
Fluid outlet size	1" npt(f)
Weight	approx. 73 kg (160 lb)
Displacement pump weight	approx. 37 kg (81 lb)
Wetted parts	Carbon Steel; Chrome, Zinc, and Nickel Plating; 304, 316, 440, and 17-4 PH Grades of Stainless Steel; Alloy Steel; Ductile Iron; PTFE; Glass-Filled PTFE; Ultra-High Molecular Weight Polyethylene

### Sound Pressure Levels dB(A) (measured at 1 meter from unit)

	Input Air Pressures at 15 cycles per minute			
	0.28 MPa, 2.8 bar (40 psi)	0.48 MPa, 4.8 bar (70 psi)	0.63 MPa, 6.3 bar (90 psi)	0.7 MPa, 7 bar (100 psi)
Bulldog	82.4 dB(A)	87.3 dB(A)	88.5 dB(A)	90.0 dB(A)

### Sound Power Levels dB(A) (tested in accordance with ISO 9614-2)

	Input Air Pressures at 15 cycles per minute			
	0.28 MPa, 2.8 bar (40 psi)	0.48 MPa, 4.8 bar (70 psi)	0.63 MPa, 6.3 bar (90 psi)	0.7 MPa, 7 bar (100 psi)
Bulldog	91.6 dB(A)	95.9 dB(A)	97.4 dB(A)	98.1 dB(A)

# Technical Data

(Model 237261, 246940 and 241901 Bulldog Pump)

## Performance Charts

**To find Fluid Outlet Pressure** (psi/MPa/bar) at a specific fluid flow (lpm/gpm) and operating air pressure (psi/MPa/bar):

1. Locate desired flow along bottom of chart.
2. Follow vertical line up to intersection with selected fluid outlet pressure curve (black). Follow left to scale to read fluid outlet pressure.

**To find Pump Air Consumption** (m<sup>3</sup>/min or scfm) at a specific fluid flow (lpm/gpm) and air pressure (psi/MPa/bar):

1. Locate desired flow along bottom of chart.
2. Read vertical line up to intersection with selected air consumption curve (dashes). Follow left to scale to read air consumption.

- A** 0.7 MPa, 7 bar (100 psi) air pressure
- B** 0.5 MPa, 4.9 bar (70 psi) air pressure
- C** 0.3 MPa, 2.8 bar (40 psi) air pressure

### Test Fluid: No. 10 Weight Oil

**Fluid Outlet Pressure**

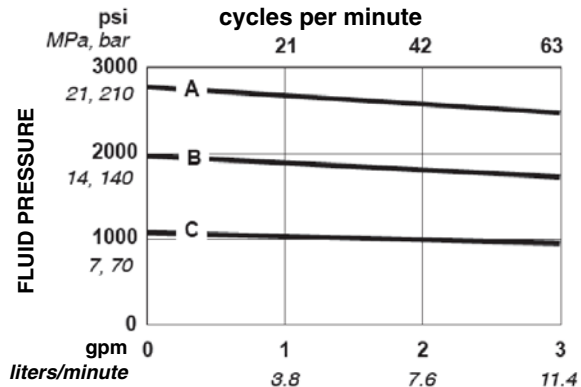

**Air Consumption**

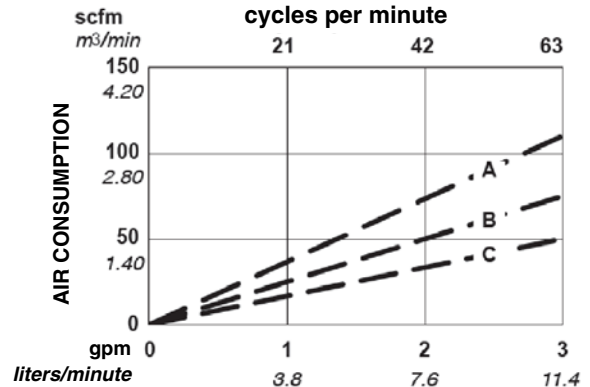

### Test Fluid: 4 Million CPS Weldable Rubber Base Sealer

**Fluid Outlet Pressure**

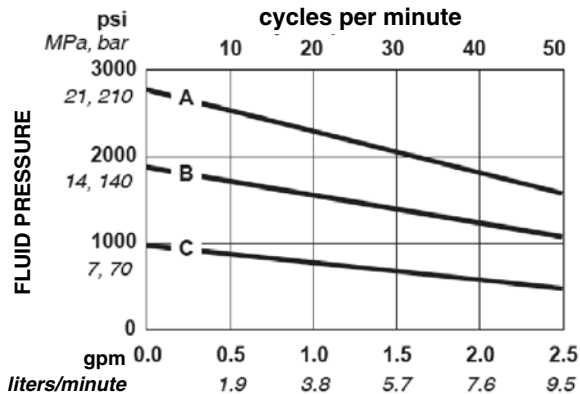

**Air Consumption**

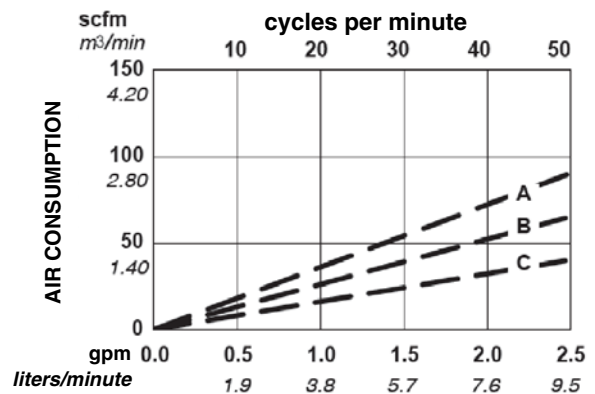

# Technical Data

## (Model 237274 Reduced Icing Quiet Bulldog Pump)

### WARNING

Be sure that all fluids and solvents used are chemically compatible with the Wetted Parts listed below. Always read the manufacturer's literature before using fluid or solvent in this pump.

Category	Data
Ratio	31:1
Maximum fluid working pressure	21 MPa, 214 bar (3100 psi)
Maximum air input pressure	0.7 MPa, 7 bar (100 psi)
Pump cycles per 3.8 liters (1 gal.)	21
Fluid flow at 60 cycles/min	10.6 liters/min (2.8 gpm)
Air motor piston effective area	248 cm <sup>2</sup> (38 in. <sup>2</sup> )
Stroke length	120 mm (4.75 in.)
Displacement pump effective area	8 cm <sup>2</sup> (1.24 in. <sup>2</sup> )
Maximum pump operating temperature	82°C (180°F)
Air inlet size	3/4 npsm(f)
Fluid outlet size	1" npt(f)
Weight	approx. 73 kg (160 lb)
Displacement pump weight	approx. 37 kg (81 lb)
Wetted parts	Carbon Steel; Chrome, Zinc, and Nickel Plating; 304, 316, 440, and 17-4 PH Grades of Stainless Steel; Alloy Steel; Ductile Iron; PTFE; Glass-Filled PTFE; Ultra-High Molecular Weight Polyethylene

### Sound Pressure Levels dB(A) (measured at 1 meter from unit)

	Input Air Pressures at 15 cycles per minute			
	0.28 MPa, 2.8 bar (40 psi)	0.48 MPa, 4.8 bar (70 psi)	0.63 MPa, 6.3 bar (90 psi)	0.7 MPa, 7 bar (100 psi)
<b>Air Motor</b>				
Reduced Icing Quiet Bulldog	81.5 dB(A)	83.6 dB(A)	85.6 dB(A)	85.8 dB(A)

### Sound Power Levels dB(A) (tested in accordance with ISO 9614-2)

	Input Air Pressures at 15 cycles per minute			
	0.28 MPa, 2.8 bar (40 psi)	0.48 MPa, 4.8 bar (70 psi)	0.63 MPa, 6.3 bar (90 psi)	0.7 MPa, 7 bar (100 psi)
<b>Air Motor</b>				
Reduced Icing Quiet Bulldog	90.2 dB(A)	93.5 dB(A)	94.9 dB(A)	93.3 dB(A)

# Technical Data

## (Model 237274 Reduced Icing Quiet Bulldog Pump)

### Performance Charts

**To find Fluid Outlet Pressure** (psi/MPa/bar) at a specific fluid flow (lpm/gpm) and operating air pressure (psi/MPa/bar):

1. Locate desired flow along bottom of chart.
2. Follow vertical line up to intersection with selected fluid outlet pressure curve (black). Follow left to scale to read fluid outlet pressure.

**To find Pump Air Consumption** (m<sup>3</sup>/min or scfm) at a specific fluid flow (lpm/gpm) and air pressure (psi/MPa/bar):

1. Locate desired flow along bottom of chart.
2. Read vertical line up to intersection with selected air consumption curve (dashes). Follow left to scale to read air consumption.

- A** 0.7 MPa, 7 bar (100 psi) air pressure
- B** 0.5 MPa, 4.9 bar (70 psi) air pressure
- C** 0.3 MPa, 2.8 bar (40 psi) air pressure

### Test Fluid: No. 10 Weight Oil

**Fluid Outlet Pressure**

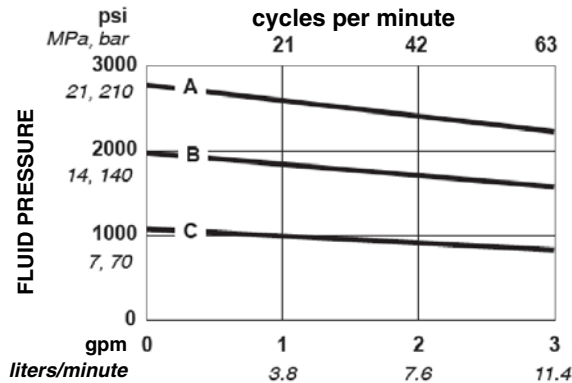

**Air Consumption**

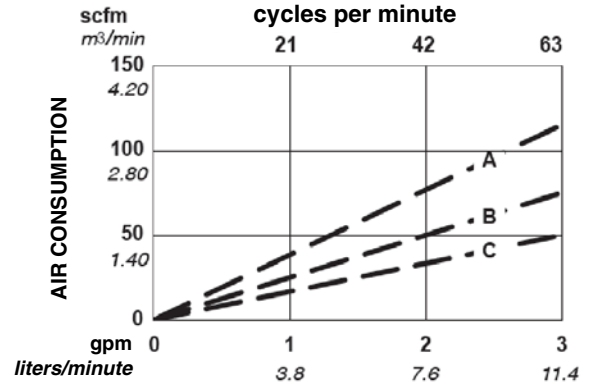

### Test Fluid: 4 Million CPS Weldable Rubber Base Sealer

**Fluid Outlet Pressure**

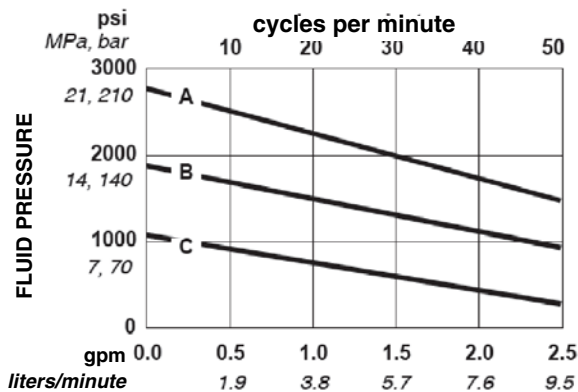

**Air Consumption**

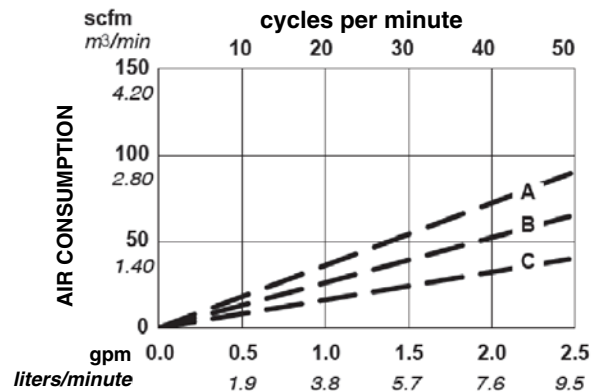

# Technical Data

(Model 237264 and 246941 Senator Pumps)

## WARNING

Be sure that all fluids and solvents used are chemically compatible with the Wetted Parts listed below. Always read the manufacturer's literature before using fluid or solvent in this pump.

Category	Data
Ratio	19:1
Maximum fluid working pressure	15 MPa, 157 bar (2280 psi)
Maximum air input pressure	0.8 MPa, 8.4 bar (120 psi)
Pump cycles per 3.8 liters (1 gal.)	21
Fluid flow at 60 cycles/min	10.6 liters/min (2.8 gpm)
Air motor piston effective area	154 cm <sup>2</sup> (24 in. <sup>2</sup> )
Stroke length	120 mm (4.75 in.)
Displacement pump effective area	8 cm <sup>2</sup> (1.24 in. <sup>2</sup> )
Maximum pump operating temperature	82°C (180°F)
Air inlet size	3/4 npsm(f)
Fluid outlet size	1" npt(f)
Weight	approx. 73 kg (160 lb)
Displacement pump weight	approx. 37 kg (81 lb)
Wetted parts	Carbon Steel; Chrome, Zinc, and Nickel Plating; 304, 316, 440, and 17-4 PH Grades of Stainless Steel; Alloy Steel; Ductile Iron; PTFE; Glass-Filled PTFE; Ultra-High Molecular Weight Polyethylene

### Sound Pressure Levels dB(A) (measured at 1 meter from unit)

	Input Air Pressures at 15 cycles per minute			
	40 psi (2.8 bar, 280 kPa)	70 psi (4.8 bar, 480 kPa)	90 psi (6 bar, 600 kPa)	100 psi (7 bar, 700 kPa)
Air Motor				
Standard Senator	84.3 dB(A)	87.8 dB(A)	89.8 dB(A)	91.2 dB(A)

### Sound Power Levels dB(A) (tested in accordance with ISO 9614-2)

	Input Air Pressures at 15 cycles per minute			
	40 psi (2.8 bar, 280 kPa)	70 psi (4.8 bar, 480 kPa)	90 psi (6 bar, 600 kPa)	100 psi (7 bar, 700 kPa)
Air Motor				
Standard Senator	91.6 dB(A)	94.6 dB(A)	96.4 dB(A)	97.3 dB(A)

# Technical Data

(Model 237264 and 246941 Senator Pumps)

## Performance Charts

**To find Fluid Outlet Pressure** (psi/MPa/bar) at a specific fluid flow (lpm/gpm) and operating air pressure (psi/MPa/bar):

1. Locate desired flow along bottom of chart.
2. Follow vertical line up to intersection with selected fluid outlet pressure curve (black). Follow left to scale to read fluid outlet pressure.

**To find Pump Air Consumption** (m<sup>3</sup>/min or scfm) at a specific fluid flow (lpm/gpm) and air pressure (psi/MPa/bar):

1. Locate desired flow along bottom of chart.
2. Read vertical line up to intersection with selected air consumption curve (dashes). Follow left to scale to read air consumption.

- A** 0.8 MPa, 8.4 bar (120 psi) air pressure
- B** 0.7 MPa, 7 bar (100 psi) air pressure
- C** 0.5 MPa, 4.9 bar (70 psi) air pressure

### Test Fluid: No. 10 Weight Oil

**Fluid Outlet Pressure**

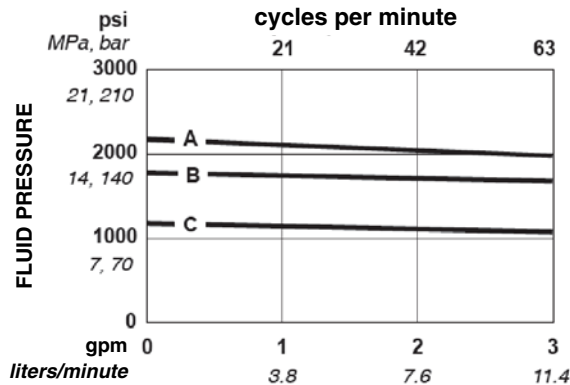

**Air Consumption**

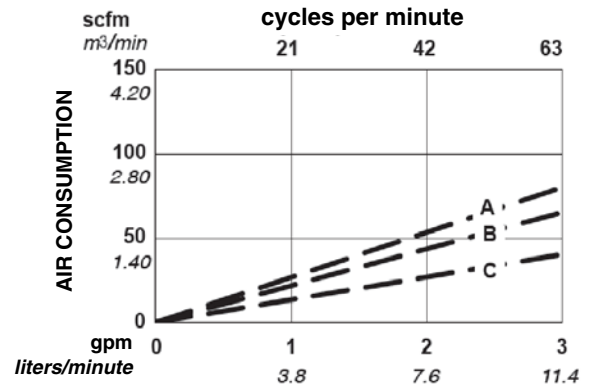

### Test Fluid: 4 Million CPS Weldable Rubber Base Sealer

**Fluid Outlet Pressure**

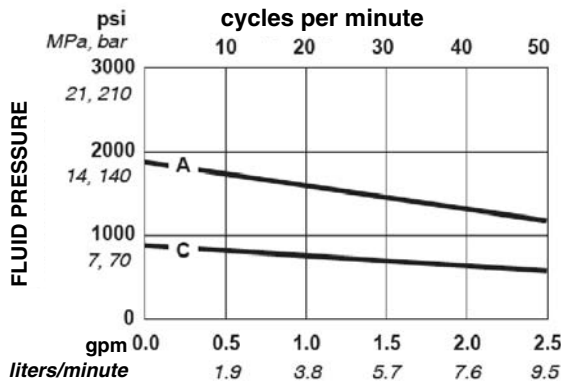

**Air Consumption**

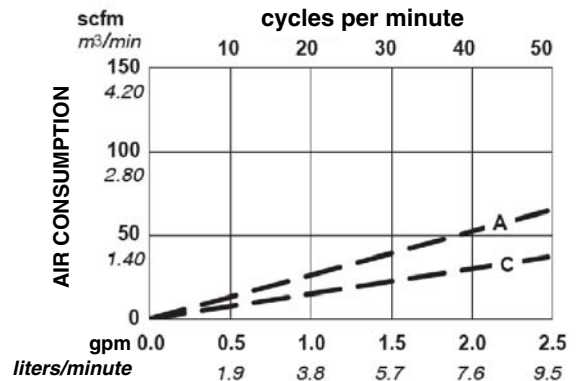

# Technical Data

(Model 198466 and 246938 Viscount II Pumps)

## WARNING

Be sure that all fluids and solvents used are chemically compatible with the Wetted Parts listed below. Always read the manufacturer's literature before using fluid or solvent in this pump.

Category	Data
Maximum fluid working pressure	40 MPa, 403 bar (5850 psi)
Maximum hydraulic fluid input pressure	10.3 MPa, 103 bar (1500 psi)
Pump cycles per 3.8 liters (1 gal.)	21
Fluid flow at 60 cycles/min	10.6 liters/min (2.8 gpm)
Hydraulic motor piston effective area	31.6 cm <sup>2</sup> (4.9 in. <sup>2</sup> )
Stroke length	120 mm (4.75 in.)
Displacement pump effective area	8 cm <sup>2</sup> (1.24 in. <sup>2</sup> )
Maximum pump operating temperature	82°C (180°F)
Hydraulic fluid inlet size	G1/2
Fluid outlet size	1" npt(f)
Weight	approx. 80 kg (177 lb)
Displacement pump weight	approx. 37 kg (81 lb)
Wetted parts	Carbon Steel; Chrome, Zinc, and Nickel Plating; 304, 316, 440, and 17-4 PH Grades of Stainless Steel; Alloy Steel; Ductile Iron; PTFE; Glass-Filled PTFE; Ultra-High Molecular Weight Polyethylene

### Sound Pressure Levels dB(A) (measured at 1 meter from unit)

Hydraulic Motor	Input Hydraulic Pressures at 25 cycles/min
Viscount II	10 MPa, 100 bar (1450 psi) 88 dB(A)

### Sound Power Levels dB(A) (tested in accordance with ISO 3744)

Hydraulic Motor	Input Hydraulic Pressures at 25 cycles/min
Viscount II	10 MPa, 100 bar (1450 psi) 103 dB(A)



# Dimensions and Mounting Hole Layout

Model 236471 Shown

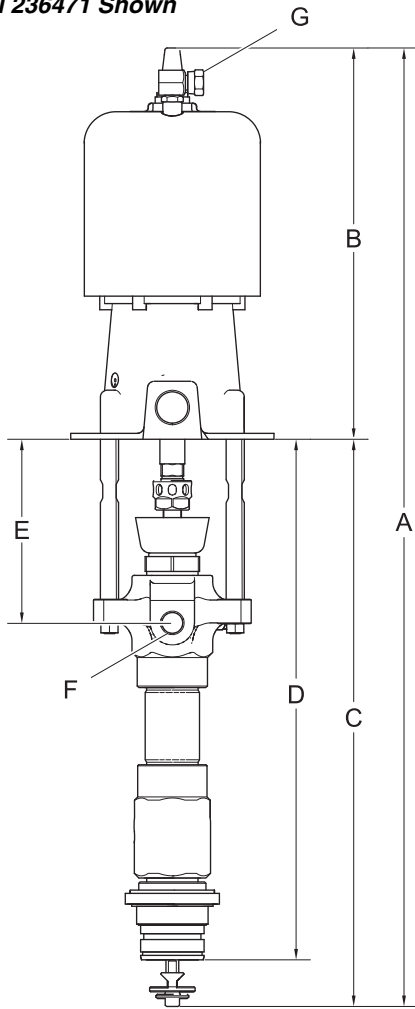

All Models, except 198466 and 246938

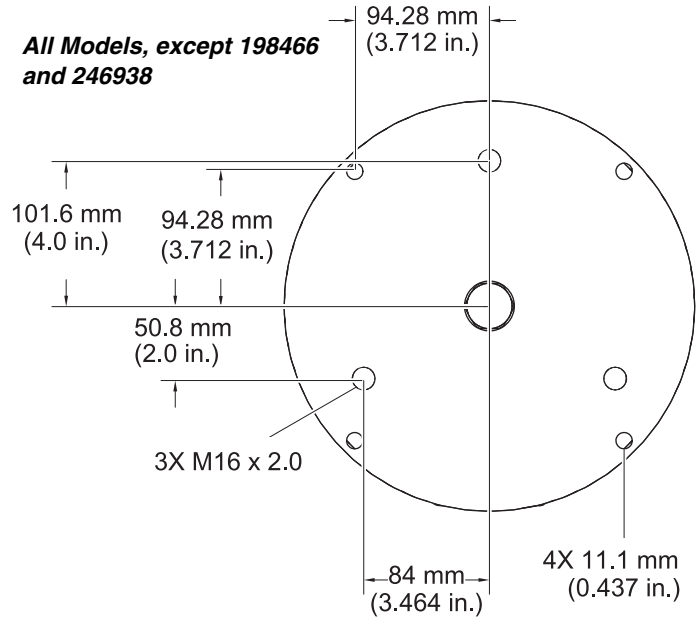

Model 198466 and 246938

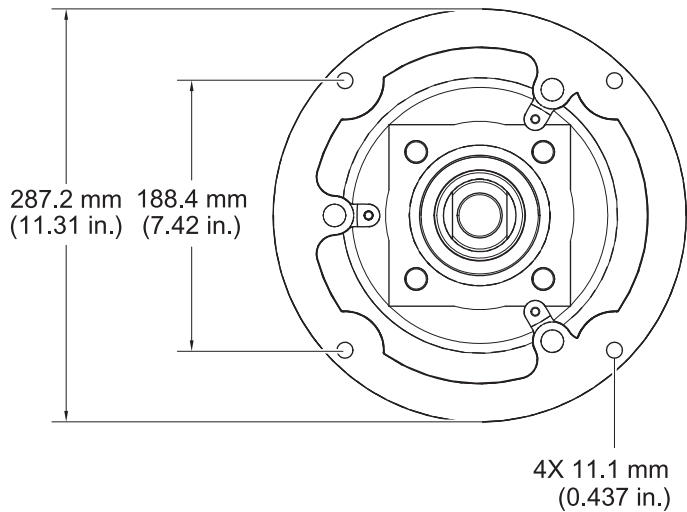

1136090a

Part No.	A	B	C	D	E	F	G
236471 246942	1376.7 mm (54.20 in.)	583.0 mm (22.95 in.)	793.7 mm (31.25 in.)	728.5 mm (28.68 in.)	257.0 mm (10.12 in.)	1 in. npt(f)	3/4 npsm(f)
237265 240945 253376	1383.0 mm (54.33 in.)	589.6 mm (23.21 in.)	793.7 mm (31.25 in.)	728.5 mm (28.68 in.)	257.0 mm (10.12 in.)	1 in. npt(f)	3/4 npsm(f)
237261 246940	1338.0 mm (52.68 in.)	544.0 mm (21.42 in.)	793.7 mm (31.25 in.)	728.5 mm (28.68 in.)	257.0 mm (10.12 in.)	1 in. npt(f)	3/4 npsm(f)
241901	1494 mm (58.82 in.)	544.0 mm (21.42 in.)	949.0 mm (37.39 in.)	884.0 mm (34.82 in.)	413.0 mm (16.26 in.)	1 in. npt(f)	3/4 npsm(f)
237274	1388.0 mm (54.65 in.)	595.0 mm (23.43 in.)	793.7 mm (31.25 in.)	728.5 mm (28.68 in.)	257.0 mm (10.12 in.)	1 in. npt(f)	3/4 npsm(f)
237264 246941	1341.0 mm (52.80 in.)	548.0 mm (21.57 in.)	793.7 mm (31.25 in.)	728.5 mm (28.68 in.)	257.0 mm (10.12 in.)	1 in. npt(f)	3/4 npsm(f)
198466 246938	1438.86 mm (56.65 in.)	645.16 mm (25.4 in.)	793.7 mm (31.25 in.)	728.5 mm (28.68 in.)	257.0 mm (10.12 in.)	1 in. npt(f)	G 1/2
198475	1339.7 mm (52.74 in.)	546.0 mm (21.5 in.)	793.7 mm (31.25 in.)	728.5 mm (28.68 in.)	257.0 mm (10.12 in.)	1 in. npt(f)	G 1/2

# Graco Standard Warranty

Graco warrants all equipment manufactured by Graco and bearing its name to be free from defects in material and workmanship on the date of sale to the original purchaser for use. With the exception of any special, extended, or limited warranty published by Graco, Graco will, for a period of twelve months from the date of sale, repair or replace any part of the equipment determined by Graco to be defective. This warranty applies only when the equipment is installed, operated and maintained in accordance with Graco's written recommendations.

This warranty does not cover, and Graco shall not be liable for general wear and tear, or any malfunction, damage or wear caused by faulty installation, misapplication, abrasion, corrosion, inadequate or improper maintenance, negligence, accident, tampering, or substitution of non-Graco component parts. Nor shall Graco be liable for malfunction, damage or wear caused by the incompatibility of Graco equipment with structures, accessories, equipment or materials not supplied by Graco, or the improper design, manufacture, installation, operation or maintenance of structures, accessories, equipment or materials not supplied by Graco.

This warranty is conditioned upon the prepaid return of the equipment claimed to be defective to an authorized Graco distributor for verification of the claimed defect. If the claimed defect is verified, Graco will repair or replace free of charge any defective parts. The equipment will be returned to the original purchaser transportation prepaid. If inspection of the equipment does not disclose any defect in material or workmanship, repairs will be made at a reasonable charge, which charges may include the costs of parts, labor, and transportation.

**THIS WARRANTY IS EXCLUSIVE, AND IS IN LIEU OF ANY OTHER WARRANTIES, EXPRESS OR IMPLIED, INCLUDING BUT NOT LIMITED TO WARRANTY OF MERCHANTABILITY OR WARRANTY OF FITNESS FOR A PARTICULAR PURPOSE.**

Graco's sole obligation and buyer's sole remedy for any breach of warranty shall be as set forth above. The buyer agrees that no other remedy (including, but not limited to, incidental or consequential damages for lost profits, lost sales, injury to person or property, or any other incidental or consequential loss) shall be available. Any action for breach of warranty must be brought within two (2) years of the date of sale.

Graco makes no warranty, and disclaims all implied warranties of merchantability and fitness for a particular purpose in connection with accessories, equipment, materials or components sold but not manufactured by Graco. These items sold, but not manufactured by Graco (such as electric motors, switches, hose, etc.), are subject to the warranty, if any, of their manufacturer. Graco will provide purchaser with reasonable assistance in making any claim for breach of these warranties.

In no event will Graco be liable for indirect, incidental, special or consequential damages resulting from Graco supplying equipment hereunder, or the furnishing, performance, or use of any products or other goods sold hereto, whether due to a breach of contract, breach of warranty, the negligence of Graco, or otherwise.

## **FOR GRACO CANADA CUSTOMERS**

The parties acknowledge that they have required that the present document, as well as all documents, notices and legal proceedings entered into, given or instituted pursuant hereto or relating directly or indirectly hereto, be drawn up in English. Les parties reconnaissent avoir convenu que la rédaction du présent document sera en Anglais, ainsi que tous documents, avis et procédures judiciaires exécutés, donnés ou intentés à la suite de ou en rapport, directement ou indirectement, avec les procédures concernées.

# Graco Information

**TO PLACE AN ORDER**, contact your Graco distributor, or call one of the following numbers to identify the distributor closest to you:

**1-800-328-0211 Toll Free**

**612-623-6921**

**612-378-3505 Fax**

All written and visual data contained in this document reflects the latest product information available at the time of publication. Graco reserves the right to make changes at any time without notice.

Original instructions. This manual contains English. MM 308351

**Graco Headquarters:** Minneapolis

**International Offices:** Belgium, China, Japan, Korea

**GRACO INC. AND SUBSIDIARIES • P.O. BOX 1441 • MINNEAPOLIS MN 55440-1441 • USA**

Copyright 1995, Graco Inc. All Graco manufacturing locations are registered to ISO 9001.

[www.graco.com](http://www.graco.com)

Revision M, November 2019