

GL-33[®] (Grease) and GL-42[®] (Oil) Injectors

334495F
EN

For Single-Line, Parallel, and Automatic Injector Systems dispensing grease, N.L.G.I. grades #000 - #2 and oil (minimum SAE 10 weight).

3500 psi (24 MPa, 241 bar) Maximum Working Pressure - Grease Models
1000 psi (6.89 MPa, 68.9 bar) Maximum Working Pressure - Oil Models

Model Nos.:

	GL-33 1/8 nptf	GL-33 1/8 bspp	GL-33 SST 1/8 nptf	GL-33 SST 1/8 bspp	GL-42 1/8 nptf	GL-42 1/8 bspp
Stand-Alone	24W487 24W488		24W489 24W490		24W493 24W494	
Replacement	24W483	24W484	24W485	24W486	24W491	24W492
Replacement*	25P458	25P459	25P460	25P461	25P462	25P463
1X Manifold	24W401	24W501	24W601	24W701	24W801	24W901
2X Manifold	24W402	24W502	24W602	24W702	24W802	24W902
3X Manifold	24W403	24W503	24W603	24W703	24W803	24W903
4X Manifold	24W404	24W504	24W604	24W704	24W804	24W904
5X Manifold	24X302	24X303	24X304	24X305	24X306	24X307
6X Manifold	24W405	24W505	24W605	24W705	24W805	24W905
7X Manifold	25R873					
9X Manifold	24W406				24W806	
10X Manifold	24W407	24W506	24W606	24W706	24W807	24W906
15X Manifold	24W408	24W507	24W607	24W707	24W808	24W907

*Replacements of individual injectors for corresponding Lincoln, Dropsa, and Bijur models





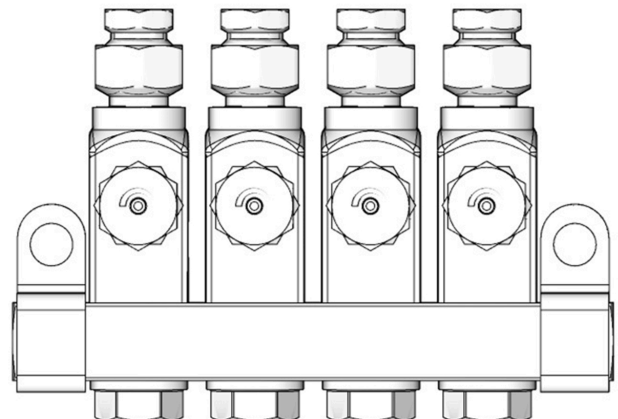

Important Safety Instructions

Read all warnings and instructions in this manual and in the pump instruction manual included with your system. Save all instructions.



Warnings

The following warnings are for the setup, use, grounding, maintenance, and repair of this equipment. The exclamation point symbol alerts you to a general warning and the hazard symbols refer to procedure-specific risks. When these symbols appear in the body of this manual or on warning labels, refer back to these Warnings. Product-specific hazard symbols and warnings not covered in this section may appear throughout the body of this manual where applicable.

 WARNING	
	<p>FIRE AND EXPLOSION HAZARD</p> <p>When flammable fluids are present in the work area, such as gasoline and windshield wiper fluid, be aware that flammable fumes can ignite or explode. To help prevent fire and explosion:</p> <ul style="list-style-type: none"> • Use equipment only in well ventilated area. • Eliminate all ignition sources, such as cigarettes and portable electric lamps. • Keep work area free of debris, including rags and spilled or open containers of solvent and gasoline. • Do not plug or unplug power cords or turn lights on or off when flammable fumes are present. • Ground all equipment in the work area. • Use only grounded hoses. • Stop operation immediately if static sparking occurs or you feel a shock. Do not use equipment until you identify and correct the problem. • Keep a working fire extinguisher in the work area.
	<p>SKIN INJECTION HAZARD</p> <p>High-pressure fluid from dispensing device, hose leaks, or ruptured components will pierce skin. This may look like just a cut, but it is a serious injury that can result in amputation. Get immediate surgical treatment.</p> <ul style="list-style-type: none"> • Do not point dispensing device at anyone or at any part of the body. • Do not put your hand over the fluid outlet. • Do not stop or deflect leaks with your hand, body, glove, or rag. • Follow the Pressure Relief Procedure when you stop dispensing and before cleaning, checking, or servicing equipment. • Tighten all fluid connections before operating the equipment. • Check hoses and couplings daily. Replace worn or damaged parts immediately.
	<p>PERSONAL PROTECTIVE EQUIPMENT</p> <p>Wear appropriate protective equipment when in the work area to help prevent serious injury, including eye injury, hearing loss, inhalation of toxic fumes, and burns. This protective equipment includes but is not limited to:</p> <ul style="list-style-type: none"> • Protective eyewear, and hearing protection. • Respirators, protective clothing, and gloves as recommended by the fluid and solvent manufacturer.

Installation

Pressure Relief Procedure



Follow the Pressure Relief Procedure whenever you see this symbol.



This equipment may stay pressurized or may become pressurized by an automatic lubrication cycle initiated by a lubrication controller. To help prevent serious injury from pressurized fluid, such as skin injection, splashing fluid and moving parts, follow the Pressure Relief Procedure before cleaning, checking, or servicing the equipment.

1. Disconnect power to the lubrication controller.
2. If connected to an air supply, disconnect air supply to pump module to ensure the system is depressurized.
3. Consult your pump manual for any additional pressure relief instructions related to your pump module.

Adjustment Instructions

Reference numbers used in the following instructions refer to FIG. 1.

1. Loosen lock nut (7).
2. Hand tighten the Adjuster Nut (8) then loosen, approximately 1/2 turn to achieve the minimum dispensed output volume (0.001 in.³).

NOTE: Any output setting below 1/2 turn should be monitored to verify actual output volume.

3. Retracting the Adjuster Nut (8) one and three-quarter turns from the hand-tight position permits a maximum dispensed output volume (0.003 in.³) This is the factory, preset position.

NOTE:

- Each full turn out represents an addition of approximately 0.0018 in.³ volume output.

- The amount of dispensed volume can vary depending on external conditions such as lubricant temperature and back pressure from the downstream connection.

4. When the injector has been adjusted for the proper lubricant output, wrench tighten the stroke adjustment lock nut (7).

NOTICE

To prevent component failure, the adjustment nut (8) must not be extended beyond the fully retracted position of the piston (6). See FIG. 1.

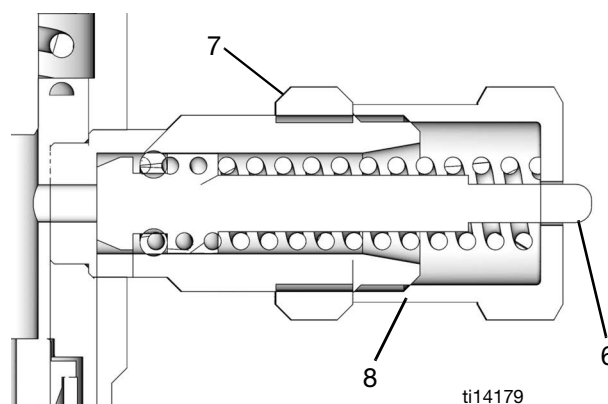

FIG. 1

ti14179

Installation Instructions

Reference letters used in the following instructions, refer to FIG. 2.

- Group injectors to minimize feed line length.
- Install injectors in locations that allow easy and safe servicing access.
- Install injectors in areas that minimize accidental injector damage by moving equipment.
- Injector outputs can be combined for a common bearing point with a large grease requirement but the output for a single injector cannot be split into multiple bearing points.
- Graco recommends using steel tubing instead of pipe and hose for supply lines when possible. Pipe is often contaminated with scale and requires proper cleaning prior to use. Hose lines expand under pressure which leads to longer pump cycle time.



1. Relieve pressure. See **Pressure Relief Procedure**, page 3.
2. Install injectors on a flat, hard surface using mounting brackets (a).
3. Connect fluid supply line (c) to injectors.

NOTICE

To prevent rupturing supply lines due to over-pressurizing the components, only use supply lines and fittings that meet or exceed the pressure rating of the injectors.

4. Connect lube point feed lines (b).
5. Flush the system with low viscosity oil or mineral spirits to remove contamination introduced during installation.
6. Use a purge gun or run the pump until clean lubricant is dispensed at the end of each feed line to purge the system of flushing fluid or air.
7. Run the system at full output and verify that all injectors are cycling.
8. Adjust injector volume output. (See Adjustment Instructions, page 3.)
9. Connect feed lines to lubrication points.

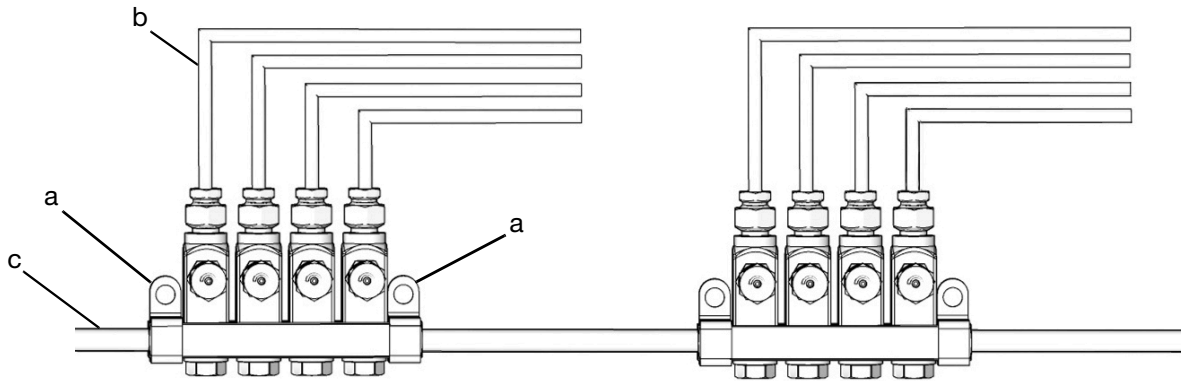

ti24505a

FIG. 2

Operation

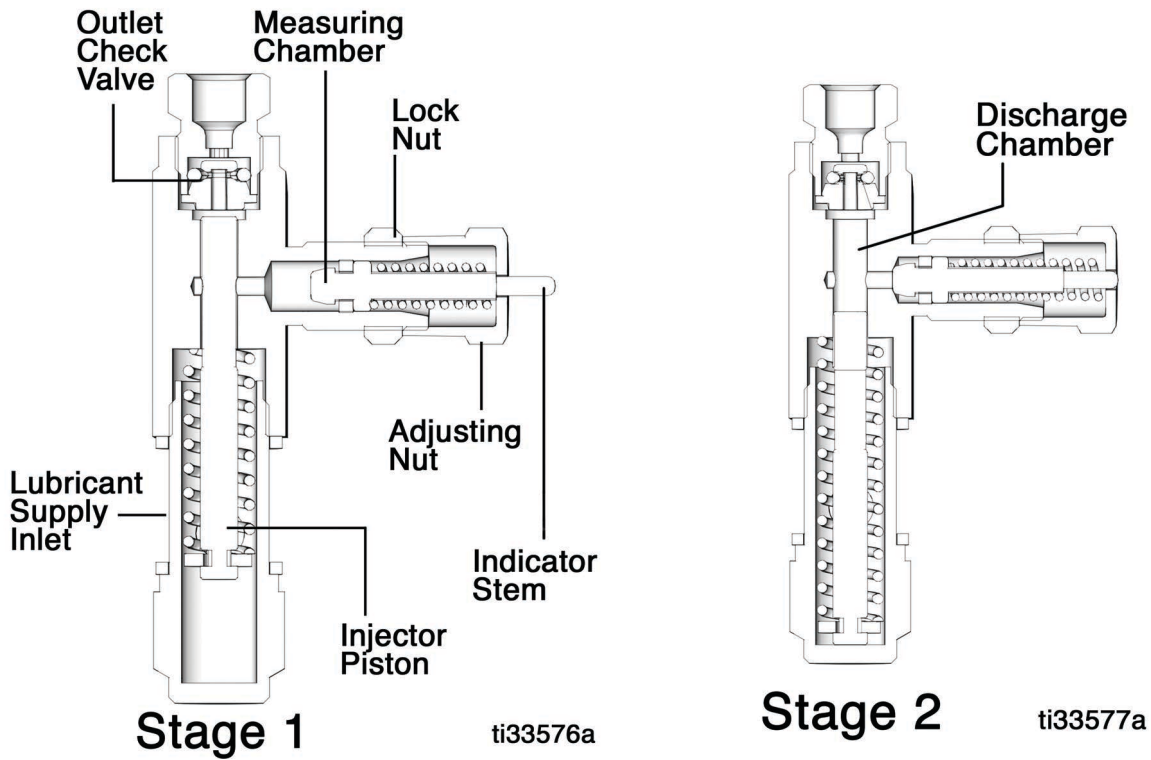

FIG. 3

Stage 1

Pressurized fluid moves the injector piston forward and forces fluid through the outlet check valve to the feed line.

Stage 2

After fluid is discharged, the pressure is relieved and the injector piston returns to the rest position. Lubricant in the measuring chamber returns to the discharge chamber.

Parts

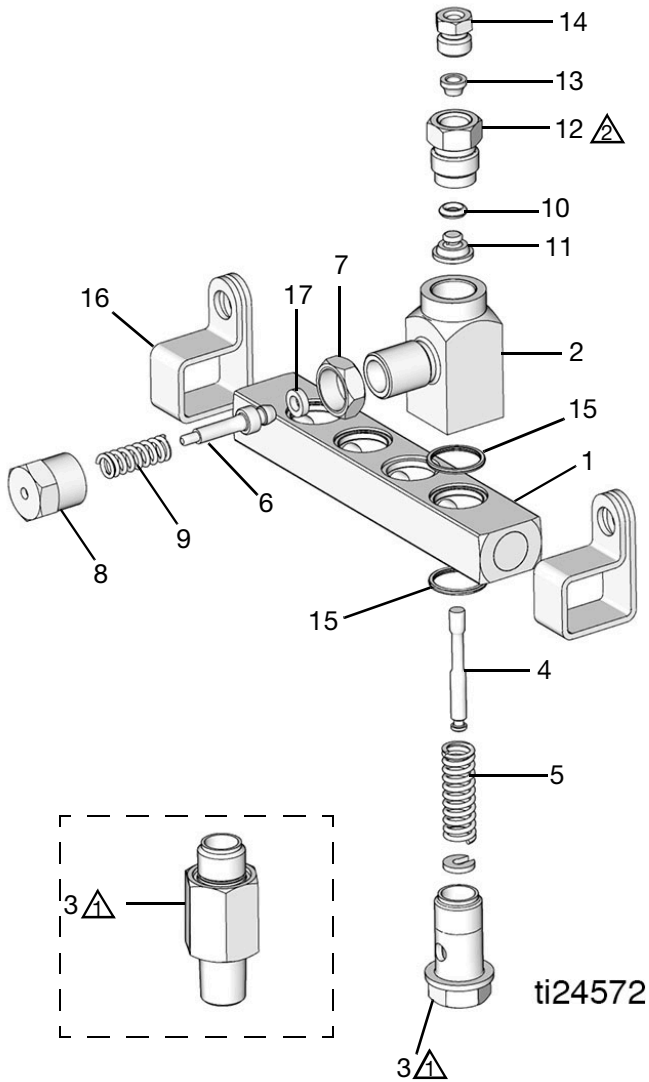

Torque to 15-16 ft. lbs (20.3 - 21.7 N•m)

Torque to 50-60 in. lbs (5.6 - 6.7 N•m)

Ref.	Part No.	Description	Qty
	17B871	BLOCK, manifold, 1 injector, 1/8 nptf (model 24W401, 24W801)	1
	17B951	BLOCK, manifold, SST, 1 injector, 1/8 nptf (model 24W601)	1
	17B872	BLOCK, manifold, 2 injector, 1/8 nptf (model 24W402, 24W802)	1
	17B952	BLOCK, manifold, SST, 2 injector, 1/8 nptf (model 24W602)	1
	17B873	BLOCK, manifold, 3 injector, 1/8 nptf (model 24W403, 24W803)	1
	17B953	BLOCK, manifold, SST, 3 injector, 1/8 nptf (model 24W603)	1
	17B874	BLOCK, manifold, 4 injector, 1/8 nptf (model 24W404, 24W804)	1
	17B954	BLOCK, manifold, SST, 4 injector, 1/8 nptf (model 24W604)	1
	17D731	BLOCK, manifold, 5 injector, 1/8 nptf (models 24X302, 24X306)	1
	17D733	BLOCK, manifold, SST, 5 injector, 1/8 nptf (model 24X304)	1
	17B875	BLOCK, manifold, 6 injector, 1/8 nptf (model 24W405, 24W805)	1
	17B955	BLOCK, manifold, SST, 6 injector, 1/8 nptf (model 24W605)	1
1	19Y897	BLOCK, manifold, 7 injector, 1/8 nptf (model 25R873)	1
	17B876	BLOCK, manifold, 9 injector, 1/8 nptf (model 24W406, 24W806)	1
	17B877	BLOCK, manifold, 10 injector, 1/8 nptf (model 24W407, 24W807)	1
	17B956	BLOCK, manifold, SST, 10 injector, 1/8 nptf (model 24W606)	1
	17B878	BLOCK, manifold, 15 injector, 1/8 nptf (model 24W408, 24W808)	1
	17B957	BLOCK, manifold, SST, 15 injector, 1/8 nptf (model 24W607)	1
	17B941	BLOCK, manifold, 1 injector, 1/8 bspp (model 24W501, 24W901)	1
	17B991	BLOCK, manifold, SST, 1 injector, 1/8 bspp (model 24W701)	1
	17B942	BLOCK, manifold, 2 injector, 1/8 bspp (model 24W502, 24W902)	1
	17B992	BLOCK, manifold, SST, 2 injector, 1/8 bspp (model 24W702)	1
	17B943	BLOCK, manifold, 3 injector, 1/8 bspp (model 24W503, 24W903)	1
	17B993	BLOCK, manifold, SST, 3 injector, 1/8 bspp (model 24W703)	1
	17B944	BLOCK, manifold, 4 injector, 1/8 bspp (model 24W504, 24W904)	1

Ref.	Part No.	Description	Qty
1 (cont)	17B994	BLOCK, manifold, SST, 4 injector, 1/8 bspp (model 24W704)	1
	17D732	BLOCK, manifold, 5 injector, 1/8 bspp (models 24X303, 24X308)	1
	17D734	BLOCK, manifold, SST, 5 injector, 1/8 bspp (model 24X305)	1
	17B945	BLOCK, manifold, 6 injector, 1/8 bspp (model 24W505, 24W905)	1
	17B995	BLOCK, manifold, SST, 6 injector, 1/8 bspp (model 24W705)	1
	17B946	BLOCK, manifold, 10 injector, 1/8 bspp (model 24W506, 24W906)	1
	17B996	BLOCK, manifold, SST, 10 injector, 1/8 bspp (model 24W706)	1
	17B947	BLOCK, manifold, 15 injector, 1/8 bspp (model 24W507, 24W907)	1
	17B997	BLOCK, manifold, SST, 15 injector, 1/8 bspp (model 24W707)	1
2		HOUSING	1
3	17B937	CYLINDER, inlet, 1/8-27 nptf, stand alone (models 24W487, 24W488, 24W493, 24W494)	1
	17B938	CYLINDER, inlet, 1/8-27 nptf, SST, stand alone (model 24W489, 24W490)	1
	17B868	CYLINDER, inlet, manifold (models 24W401-24W408, 24W501-24W507, 24W801-24W808, 24W901-24W907, 24W483, 24W484, 24W491, 24W492, 25P458, 25P459, 25P462, 25P463, 25R873)	1
	17B869	CYLINDER, inlet, SST, manifold (models 24W601-24W607, 24W701-24W707, 24W485, 24W486, 25P460, 25P461)	1
4		PISTON, end	1
5★		SPRING, compression, piston	1
6		PISTON, stroke	1
7		NUT, lock, stroke adjustment	1
8		ADJUSTER, nut, stroke, piston	1
9★		SPRING, compression, piston	1
10★		O-RING, 006, duro viton	1
11★		VALVE, body, one-way	1
12♣†✓		ADAPTER, outlet	1
13♣†✓		FERRULE	1
14♣†✓		NUT, compression	1

Ref.	Part No.	Description	Qty
15	17B885★	GASKET, manifold inlet (models 24W401- 24W408, 24W501-24W507, 24W601-24W607, 24W701-24W707, 24W801-24W808, 24W901-24W907, 24W483-24W494, 25R873)	2
	18A980	SPACER, copper, GL33 (models 25P458, 25P459, 25P462, 25P463)	2
	18B026	SPACER, SST, GL33 (models 25P460, 25P461)	2
16	17B948	CLIP, manifold (all carbon steel models)	2
	17B949	CLIP, manifold (all SST models)	1
17	123962	SEAL, square, GL-Series	1

★	Parts included in Injector Repair Kit: Grease: 24W913 - GL-33 carbon steel; 24W914 - GL-33 stainless steel; Oil: 24W915 - GL-42
♣	Parts included in 1/8" Outlet Fitting Kit 24B677; SST - 24F943
†	Parts included in 4 mm Outlet Fitting (Adapter) Kit 24F513; SST- 24F555
✓	Parts included in 6 mm Outlet Fitting Kit 24F514; SST- 24F556

Accessories

JIC-4 Fitting:

- 17B168 - Carbon Steel
- 17B169 - Stainless Steel

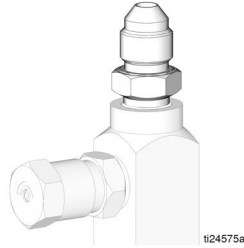

Tube Push-to-Connect Adapter:

- 17B879 - 1/8 inch O.D.
- 17B880 - 1/4 inch O.D.

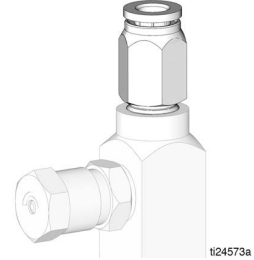

1/8 inch nptf Female Outlet Adapter:

- 17B780 - Carbon Steel
- 17B781 - Stainless Steel



Manual Grease Fitting Adapter: 24W495

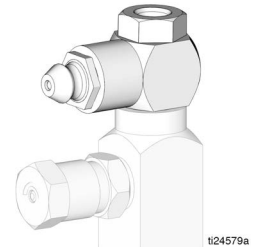

Outlet Plug:

- 17B782 - Carbon Steel
- 17B783 - Stainless Steel



Tube Outlet Adapter:

- †24F513 - 4 MM O.D., carbon steel
- †24F555 - 4 MM O.D., stainless steel
- 24B677 - 1/8 in. O.D., carbon steel
- 24F943 - 1/8 in. O.D., stainless steel
- 24F514 - 6 mm O.D., carbon steel
- 24F556 - 6 mm O.D., stainless steel



Adjustment Nut Cap: 17B785

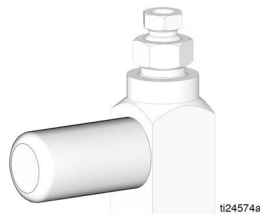

Technical Data

Oil Models

	US	Metric
Maximum Operating Pressure	1000 psi	6.89 MPa, 68.9 bar
Minimum Operating Pressure	750 psi	5.17 MPa, 51.7 bar
Suggested Operating Pressure	850 psi	5.86 MPa, 58.6 bar
Reset Pressure	150 psi	1.03 MPa, 10.3 bar
Output Volume per Cycle	adjustable: 0.001 - 0.003 in. ³	adjustable: 0.016 - 0.049 cc
Wetted Parts	carbon steel, stainless steel, fluoroelastomer	
Recommended Fluids	Minimum SAE 10 weight oil*	

Grease Models

	US	Metric
Maximum Operating Pressure	3500 psi	24 MPa, 241 bar
Minimum Operating Pressure	1200 psi	8.3 MPa, 83 bar
Suggested Operating Pressure	1500 psi	10.3 MPa, 103.4 bar
Reset Pressure	200 psi	1.4 MPa, 14 bar
Output Volume per Cycle	adjustable: 0.001 - 0.003 in. ³	adjustable: 0.016 - 0.049 cc
Wetted Parts	carbon steel, stainless steel, fluoroelastomer	
Recommended Fluids	Grease N.L.G.I. grades #000 - #2*	

*Only use fluids appropriate for your application, automatic dispensing and the equipment's operating temperature. Consult with machine and lube manufacturer for details.

Dimensions

Model 24W504 Shown

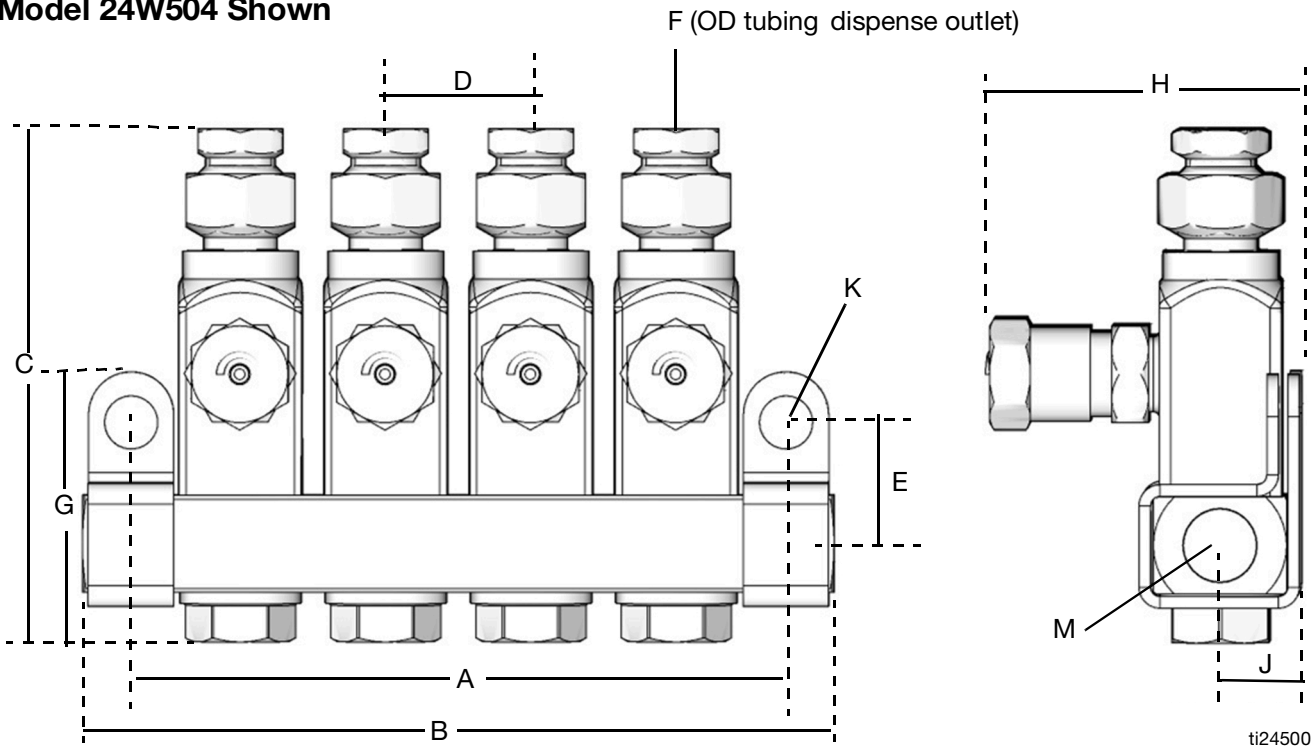

ti24500

Injector	A in. / mm	B in./mm	C in./mm	D in./mm	E in./mm	F† in./mm	G in./mm	H in./mm	J in./mm	K in./mm	M* nptf or bspp
Stand alone injector	single	manifold	2.54/ 64.6	N/A	0.62/ 15.8	0.125/ 3.2 OR 0.236/ 6.0	1.4/ 35.4	1.6/ 40.6	0.41/ 10.4	0.275/ 7.0	1/8 nptf OR 1/8 bspp
Manifold	replacement for manifold										
1 point manifold	1.13/ 0.57	1.63/ 41.4									
2 point manifold	1.88/ 47.8	2.38/ 60.5									
3 point manifold	2.63/ 66.8	3.13/ 79.5									
4 point manifold	3.38/ 85.8	3.88/ 98.5									
5 point manifold	4.13/ 104.9	4.63/ 117.6									
6 point manifold	4.88/ 124	5.38/ 136.7									
7 point manifold	5.63/ 143	6.13/ 155.7									
9 point manifold	7.13/ 181	7.63/ 193									
10 point manifold	7.88/ 200	8.38/ 213									
15 point manifold	11.63/ 295	12.13/ 308									

*To verify your injector's inlet / outlet thread type (M), see Model Nos. table provided on cover page of this manual.
 † 0.157/4.0 available as adapter kit.

Graco Standard Warranty

Graco warrants all equipment referenced in this document which is manufactured by Graco and bearing its name to be free from defects in material and workmanship on the date of sale to the original purchaser for use. With the exception of any special, extended, or limited warranty published by Graco, Graco will, for a period of twelve months from the date of sale, repair or replace any part of the equipment determined by Graco to be defective. This warranty applies only when the equipment is installed, operated and maintained in accordance with Graco's written recommendations.

This warranty does not cover, and Graco shall not be liable for general wear and tear, or any malfunction, damage or wear caused by faulty installation, misapplication, abrasion, corrosion, inadequate or improper maintenance, negligence, accident, tampering, or substitution of non-Graco component parts. Nor shall Graco be liable for malfunction, damage or wear caused by the incompatibility of Graco equipment with structures, accessories, equipment or materials not supplied by Graco, or the improper design, manufacture, installation, operation or maintenance of structures, accessories, equipment or materials not supplied by Graco.

This warranty is conditioned upon the prepaid return of the equipment claimed to be defective to an authorized Graco distributor for verification of the claimed defect. If the claimed defect is verified, Graco will repair or replace free of charge any defective parts. The equipment will be returned to the original purchaser transportation prepaid. If inspection of the equipment does not disclose any defect in material or workmanship, repairs will be made at a reasonable charge, which charges may include the costs of parts, labor, and transportation.

THIS WARRANTY IS EXCLUSIVE, AND IS IN LIEU OF ANY OTHER WARRANTIES, EXPRESS OR IMPLIED, INCLUDING BUT NOT LIMITED TO WARRANTY OF MERCHANTABILITY OR WARRANTY OF FITNESS FOR A PARTICULAR PURPOSE.

Graco's sole obligation and buyer's sole remedy for any breach of warranty shall be as set forth above. The buyer agrees that no other remedy (including, but not limited to, incidental or consequential damages for lost profits, lost sales, injury to person or property, or any other incidental or consequential loss) shall be available. Any action for breach of warranty must be brought within two (2) years of the date of sale.

GRACO MAKES NO WARRANTY, AND DISCLAIMS ALL IMPLIED WARRANTIES OF MERCHANTABILITY AND FITNESS FOR A PARTICULAR PURPOSE, IN CONNECTION WITH ACCESSORIES, EQUIPMENT, MATERIALS OR COMPONENTS SOLD BUT NOT MANUFACTURED BY GRACO. These items sold, but not manufactured by Graco (such as electric motors, switches, hose, etc.), are subject to the warranty, if any, of their manufacturer. Graco will provide purchaser with reasonable assistance in making any claim for breach of these warranties.

In no event will Graco be liable for indirect, incidental, special or consequential damages resulting from Graco supplying equipment hereunder, or the furnishing, performance, or use of any products or other goods sold hereto, whether due to a breach of contract, breach of warranty, the negligence of Graco, or otherwise.

FOR GRACO CANADA CUSTOMERS

The Parties acknowledge that they have required that the present document, as well as all documents, notices and legal proceedings entered into, given or instituted pursuant hereto or relating directly or indirectly hereto, be drawn up in English. Les parties reconnaissent avoir convenu que la rédaction du présente document sera en Anglais, ainsi que tous documents, avis et procédures judiciaires exécutés, donnés ou intentés, à la suite de ou en rapport, directement ou indirectement, avec les procédures concernées.

Graco Information

For the latest information about Graco products, visit www.graco.com.

For patent information, see www.graco.com/patents.

TO PLACE AN ORDER, contact your Graco distributor or call to identify the nearest distributor.

Phone: 612-623-6928 **or Toll Free:** 1-800-533-9655, **Fax:** 612-378-3590

*All written and visual data contained in this document reflects the latest product information available at the time of publication.
Graco reserves the right to make changes at any time without notice.*

Original instructions. This manual contains English. MM 334495

Graco Headquarters: Minneapolis

International Offices: Belgium, China, Japan, Korea

GRACO INC. AND SUBSIDIARIES • P.O. BOX 1441 • MINNEAPOLIS MN 55440-1441 • USA

Copyright 2014, Graco Inc. All Graco manufacturing locations are registered to ISO 9001.

www.graco.com

Revision F, December 2022